

No. 695,663.

Patented Mar. 18, 1902.

J. E. WEIRICH.

PORTABLE FLAG SIGNAL STANDARD.

(Application filed Dec. 20, 1901.)

(No Model.)

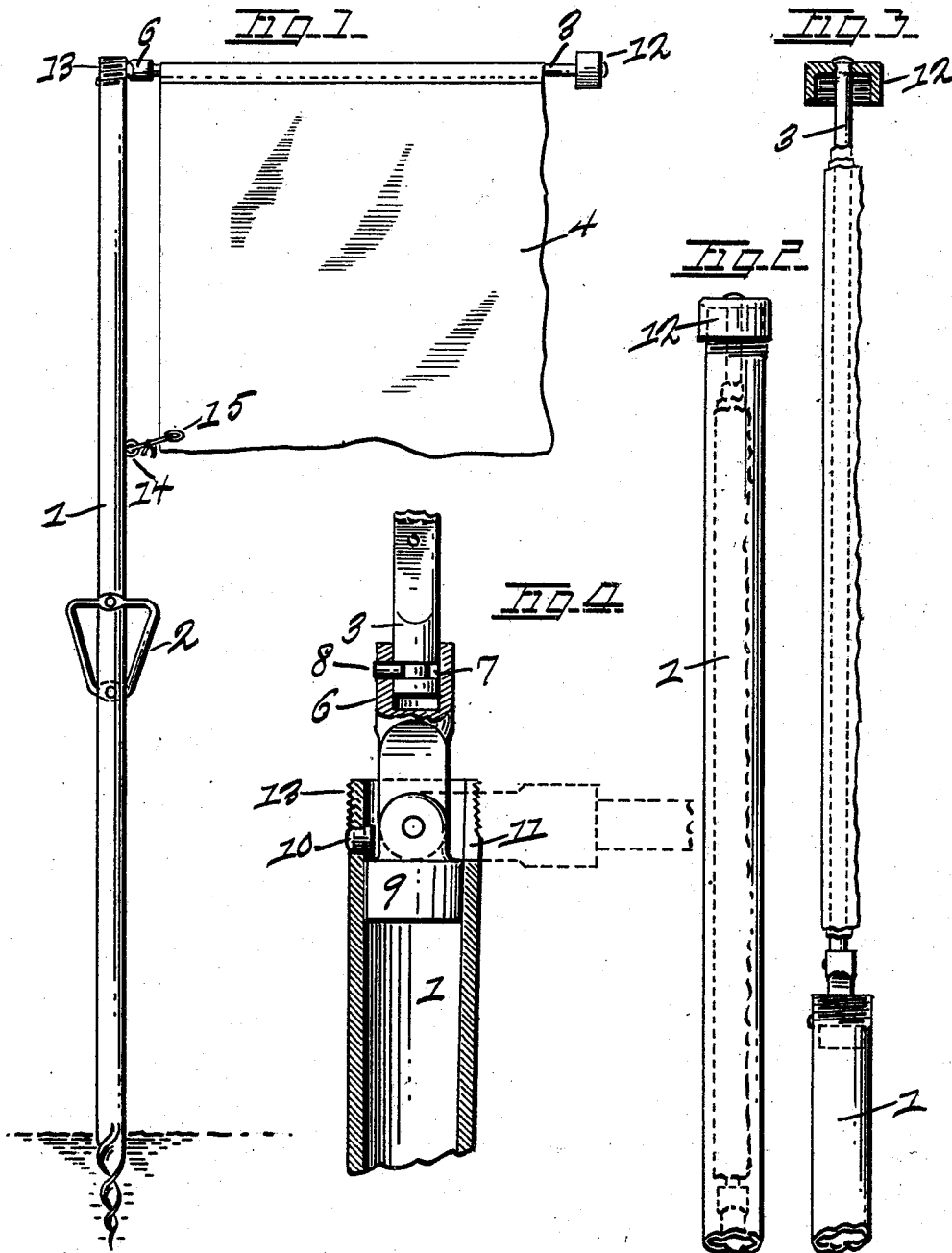

WITNESSES

Carl H. Keller
James H. Brown

INVENTOR

James E. Weirich
By C. H. Rauch, atty.

UNITED STATES PATENT OFFICE.

JAMES E. WEIRICH, OF TOLEDO, OHIO.

PORTABLE FLAG-SIGNAL STANDARD.

SPECIFICATION forming part of Letters Patent No. 695,663, dated March 18, 1902.

Application filed December 20, 1901. Serial No. 86,644. (No model.)

To all whom it may concern:

Be it known that I, JAMES E. WEIRICH, a citizen of the United States, residing at Toledo, in the county of Lucas and State of Ohio, have invented certain new and useful Improvements in Portable Flag-Signal Standards; and I do hereby declare the following to be a full, clear, and exact description of the invention, such as will enable others skilled in the art to which it appertains to make and use the same.

My invention has reference to a flag-signal standard for railways. It frequently becomes necessary while effecting repairs to the tracks of railways or while repairing the rolling-stock upon railway-tracks to display a suitable signal to give warning to an approaching train. This signal for convenience and economy is invariably a small flag of prescribed color, and it has been the practice heretofore to display the same by attaching to a pointed wooden staff which is adapted to be driven into the ground. When the ground is frozen or otherwise hard, it often happens that the staff is splintered or broken, rendering it useless. To overcome this objection and to provide a staff for a flag-signal which shall be conveniently portable and shall permit of being easily inserted into the ground and which provides a means for housing the flag when not in use, my invention is constructed. The same embodies the novel arrangement and the parts and combination of parts hereinafter shown, described, and claimed.

In the drawings, Figure 1 shows the flag-standard as it appears when inserted into the ground. Fig. 2 shows the upper end of the tubular standard, the position of the flag when furled and housed therein being shown in dotted lines. Fig. 3 shows the flag withdrawn from the standard and prior to being unfurled. Fig. 4 is an enlarged sectional detail to disclose the working of the flag-spindle with relation to the tubular standard.

Referring to the parts, 1 is a tubular upright or standard, the same being constructed, preferably, of ordinary gas-pipe. The lower end of said standard is spirally pointed to facilitate insertion into hard or frozen ground, and intermediate of its height is secured a

handle 2, which extends upon opposite sides and provides a means for manually screwing the standard into the ground.

3 is a rod or spindle, to which the signal-flag 4 is secured by any suitable means. I prefer to flatten the spindle 3 slightly to prevent the flag from turning upon the same while being furled. I may also form equidistant perforations through the spindle 3 to facilitate securing the flag to the same. The inner end of the flag-spindle is swiveled to a socket-piece 6. An annular groove 7 near the inner end of the spindle 3 and a pin 8, cooperating therewith, secure the spindle against detachment. The socket-piece 6 is hinged to a cylindrical piece 9, which is free to move up and down within the tubular standard 1. A stop in the form of a rivet prevents the entire removal of the cylindrical piece 9 from the standard 1. The upper end of the standard 1 is vertically slotted or recessed at 11, permitting the socket-piece 6 and the flag-spindle, which is swiveled thereto, to assume the position shown in dotted lines, Fig. 4, this being the position which the parts assume when the device is in use. Upon the outer end of the flag-spindle is secured a cap 12, having internal threads, which is adapted to be screwed upon the screw-threaded upper end 13 of the standard 1, the flag having been previously furled and inserted into the standard, as shown in Fig. 2. An eye 14 may be secured upon the standard, as may also an eye 15 in the lower corner of the flag, to fasten the same down to insure its being seen when the wind is blowing.

The operation and advantages of my invention will be apparent. When the flag-standard is to be transported, the flag is furled and made to enter the tubular standard, thereby protecting the same from dirt and injury.

Having described my invention, what I claim, and desire to secure by Letters Patent, is—

1. In a flag-signal standard, a tubular upright, slotted at its upper end, a movable piece therein, a stop for said piece near the upper end of the upright, and a flag-spindle hinged at its end to said movable piece and adapted to occupy the interior of the tubular

upright when the flag-signal is to be housed and to extend at right angles thereto and enter the slot at its upper end when the flag-signal is to be displayed, as set forth.

- 5 2. In a flag-signal standard, the tubular upright provided with a slot at its upper end, a piece movable within said upright, a stop for said piece near the upper end of the upright, the socket-piece hinged to said movable piece

and the flag-spindle swiveled to said socket-piece.

In testimony whereof I hereunto affix my signature in presence of two witnesses.

JAMES E. WEIRICH.

Witnesses:

CARL H. KELLER,
I. D. CARTWRIGHT.