

(19) World Intellectual Property Organization
International Bureau



(43) International Publication Date
10 March 2005 (10.03.2005)

PCT

(10) International Publication Number
WO 2005/022303 A2

- (51) International Patent Classification⁷: **G06F**
- (21) International Application Number:
PCT/US2004/026031
- (22) International Filing Date: 10 August 2004 (10.08.2004)
- (25) Filing Language: English
- (26) Publication Language: English
- (30) Priority Data:
60/495,665 15 August 2003 (15.08.2003) US
10/688,528 21 October 2003 (21.10.2003) US
- (71) Applicant (for all designated States except US): **SCORING SYSTEMS, INC.** [US/US]; 1800 2nd Street, Suite 760, Sarasota, FL 34236 (US).
- (72) Inventors; and
- (75) Inventors/Applicants (for US only): **KANITZ, William, A.** [US/US]; 314 Bird Key Drive, Sarasota, FL 34238 (US). **OLSON, Lawrence, E.** [US/US]; 9009 Huntington Pointe, Sarasota, FL 34236 (US).
- (74) Agent: **SWIFT, Paul, F.**; McCarter & English, LLP, Four Gateway Center, 100 Mulberry Street, Newark, NJ 07102-4056 (US).

- (81) Designated States (unless otherwise indicated, for every kind of national protection available): AE, AG, AL, AM, AT, AU, AZ, BA, BB, BG, BR, BW, BY, BZ, CA, CH, CN, CO, CR, CU, CZ, DE, DK, DM, DZ, EC, EE, EG, ES, FI, GB, GD, GE, GH, GM, HR, HU, ID, IL, IN, IS, JP, KE, KG, KP, KR, KZ, LC, LK, LR, LS, LT, LU, LV, MA, MD, MG, MK, MN, MW, MX, MZ, NA, NI, NO, NZ, OM, PG, PH, PL, PT, RO, RU, SC, SD, SE, SG, SK, SL, SY, TJ, TM, TN, TR, TT, TZ, UA, UG, US, UZ, VC, VN, YU, ZA, ZM, ZW.
- (84) Designated States (unless otherwise indicated, for every kind of regional protection available): ARIPO (BW, GH, GM, KE, LS, MW, MZ, NA, SD, SL, SZ, TZ, UG, ZM, ZW), Eurasian (AM, AZ, BY, KG, KZ, MD, RU, TJ, TM), European (AT, BE, BG, CH, CY, CZ, DE, DK, EE, ES, FI, FR, GB, GR, HU, IE, IT, LU, MC, NL, PL, PT, RO, SE, SI, SK, TR), OAPI (BF, BJ, CF, CG, CI, CM, GA, GN, GQ, GW, ML, MR, NE, SN, TD, TG).

Published:
— without international search report and to be republished upon receipt of that report

For two-letter codes and other abbreviations, refer to the "Guidance Notes on Codes and Abbreviations" appearing at the beginning of each regular issue of the PCT Gazette.

(54) Title: SYSTEM AND METHOD FOR SITE-SPECIFIC ELECTRONIC RECORDKEEPING

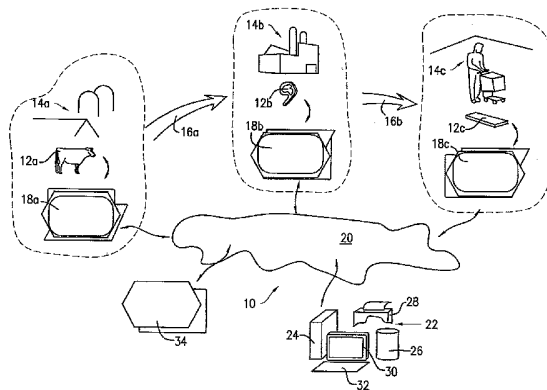

(57) Abstract: A tracking and labeling system (10) for collecting, recording and reporting data (38) on an item (12a, 12b, 12c) as the item experiences changes in state over time. The system has a plurality of node systems (18a, 18b, 18c, 18d, 18e, 18f) connected to the Internet (20) that transmit data (38) to a server (22) with database handling software. As the item (12a, 12b, 12c) is processed at various places and times (14a, 14b, 14c), the data (38) associated with the item (12a, 12b, 12c) is captured by the node systems (18a, 18b, 18c, 18d, 18e, 18f) and sent to the server database (26). At various points along the way, labels (46d, 46e, 46f) may be generated to hold a selected portion of the data (38) associated with the item (12a, 12b, 12c). The labels (46d, 46e, 46f) may be read by offline apparatus, as well as by the node systems (18a, 18b, 18c, 18d, 18e, 18f). The node systems (18a, 18b, 18c, 18d, 18e, 18f) may also print labels (46d, 46e, 46f, 50), e.g., in 2D barcode format, for updating the data (38) associated with an item (12a, 12b, 12c) as it is processed. In this manner, the label (46d, 46e, 46f, 50) contains up-to-date information on the item (12a, 12b, 12c). The system (10) permits the entire chronologically ordered site-specific history of an item to be recalled through a query directed to the server system (22) and therefore can be applied to various applications such as tracking the origin of food products for public health purposes. The server system (22) can be accessed by users on the Internet (20).

WO 2005/022303 A2

SYSTEM AND METHOD FOR SITE-SPECIFIC ELECTRONIC RECORDKEEPING

5

Technical Field of the Invention

The present technical invention relates generally to electronic recordkeeping and product labeling systems and in particular to a recordkeeping and labeling system and associated methods for providing global recordkeeping capabilities for tracking and labeling livestock, produce, wine, food products, manufactured goods and virtually any object or collection of objects as they move from place to place over time in the course of production, transportation, processing, marketing and use.

15 Background Art

Tracking the movement and state (condition) of commodities is an increasingly vital function in today's global marketplace. In some cases, public health and safety depends on the ability of investigators to trace the history of a particular commodity. In a recent example, a case of bovine spongiform encephalopathy (BSE), commonly known as mad cow disease, surfaced in Alberta, Canada. Consequently, it was necessary for officials to research the background of the diseased cow, the herd it originally came from, the farm where it lived, the plant that rendered the carcass, and the site that received the rendered product. In that case, it took investigators more than a week to determine where the cow was bred and raised on farms in Alberta and Saskatchewan. DNA testing was utilized in making the determination. In the meantime, news of the disease caused the United States and other countries to shut their borders to Canadian beef exports, causing Canadian cattle ranchers to lose tens of millions of

dollars a day. Had investigators had quicker access to a verifiable record of the background of the diseased cow, significant financial damage might have been mitigated.

- 5 The Farm Security and Rural Investment Act of 2002, more commonly known as the 2002 Farm Bill, signed into law in the United States on May 13, 2002 by President Bush, provides another example of the increasing significance of recordkeeping and tracking of commodities. One of the law's many initiatives requires country of origin labeling for beef, lamb, pork, fish, perishable agricultural commodities and peanuts.
- 10 The United States Department of Agriculture (USDA) has responsibility for implementing the COOL (Country of Origin Labeling) program. The COOL program requires suppliers to provide country of origin information to retailers, including the "born, raised, and slaughtered" information required to make U.S. origin claims for the covered commodities beef, pork, and lamb. To verify products are properly
- 15 labeled at the retail level, records must be maintained from an animal's birth to retail. The records needed to substantiate this information can be created only by recordkeepers having first-hand knowledge of each production step for the commodity. In many cases, these production steps take place in a series of geographically separated locations. Furthermore, the production steps are typically
- 20 carried out by different entities in the production chain. This requires recordkeepers situated in diverse areas of the industry to keep records for the commodity.

In addition to the concerns outlined above, the threat of bio terrorism is causing government authorities to demand more information about where food comes from

25 and how and when it's transported to market. Other health concerns are prompting

an increasing number of people in the United States and other parts of the world to demand information about whether the meat they purchase has been treated with growth hormones or antibiotics. There is a growing consumer interest in whether vegetables are grown organically and whether grain has been genetically modified.

5

Therefore, a need exists for a centralized recordkeeping and commodity tracking system and method applicable to domestic and international crops, animals and food products that can create a verifiable audit trail wherein interested persons, such as consumers and government officials, can trace the origins of beef, poultry, fish, fruit, vegetables, dairy, grain and the like the world over. Further, a need exists for an easy to use, inexpensive recordkeeping system that can record and track the entire history of a commodity quickly and cost effectively.

Besides simple identification of origin, there are various other items of information that would be desirable to record about a commodity or other entity, object or item of interest over time. For example, the condition or quality of an item or its performance characteristics and statistics, e.g., in the case of a racehorse, would be beneficial to record and have convenient access to over the lifespan of the animal. Such recordkeeping would promote evaluation of the animal with similar animals in a standardized, meaningful way.

Product labeling has been used in the past to record and communicate product information and history, e.g., content, source, country of origin. Labeling is frequently in written language and very commonly in computer-readable form, such as barcodes. UPC (Universal Product Code) symbology has been used for decades

to identify individual objects in numerous applications. This technology has given rise to a class of variants of linear coding to represent strings of numeric data, since the UPC symbol's length limits the amount of information that can be coded.

5 Another class of 2D (two-dimensional) symbology is being applied in situations where more data storage in more compact form is required. This symbology has the capability of storing long strings of alphanumeric data in very small areas by using data compression and compacting, and various coding techniques. While such labels are a relatively cheap and effective vehicle for recording and disclosing data
10 about a commodity, the data presented on a label is static (fixed in content for presentation at a particular point in the labeled object's life cycle),

Disclosure of the Invention

The limitations of prior art commodity tracking and labeling systems are addressed
15 by the present invention, which includes a system for collecting and recording data on an item as the item experiences changes in state over time. The system has a first data input device for capturing a first set of data pertaining to a first state of the item in a first environment. A second data input device captures a second set of data pertaining to a second state of the item in a second environment. The system
20 has a data processor for storing the first and second sets of data in a database. A communications link is used to transmit the first and second sets of data to the data processor. In accordance with an associated method, a first set of data pertaining to an item in a first state in a first environment is collected and recorded. When the item changes from the first state and/or the first environment, to a second state
25 and/or a second environment, a second set of data pertaining to the item is collected

and recorded. The first and second sets of data are communicated to a data processing system where they are stored in a database. The first and second sets of data in the database are selectively accessed as desired by a user of the system.

Brief Description of the Drawings

5 Figure 1 is a conceptual diagram of a tracking and labeling system in accordance with a first embodiment of the present invention.

Figure 2 is a block diagram illustrating the relationship of various components of a local, node data processing system according to a first embodiment of the invention.

10

Figure 3A is an exemplary 2D barcode that may be used in conjunction with the system of Figs. 1 and 2.

15 Figure 3B is an exemplary Data Matrix code that may be used in conjunction with the system of Figs. 1 and 2.

Figure 4 is a block diagram showing a plurality of local data processing systems according to an embodiment of the invention.

20 Figure 5 is one form of an exemplary data input/output screen according to an embodiment of the invention.

Best Mode for Carrying Out the Invention

25 Figure 1 shows a tracking and labeling system 10 for recording and reporting data about a commodity 12a, article or group of articles as it changes location and/or

state (condition) over time. As shown, a commodity, such as a steer 12a may come into existence in a first environment, viz., a farm 14a where it is born and raised. The steer 12a may be sold and shipped to a meat processing plant 14b at another location where it is butchered and processed into meat products 12b (e.g., sides of beef or other large cuts of meat). The meat products 12b may then be shipped to a retail store 14c, for further processing and packaging into retail packages of meat 12c. The transition from one state, e.g., 12a associated with one environment 14a to another state 12b, in another environment 14b, is depicted by arrows 16a, 16b, which can represent physical transportation, the passage of time or a further processing step within the same general location and closely following in time. At each point in this sequence of events, data concerning the commodity 12a, 12b, and 12c may be noted and recorded by local (node) data capture and processing systems 18a, 18b, 18c, hereinafter referred to as "node systems." Each node system 18a-18c may have different components for gathering data, transmitting, storing and sharing the data and generating outputs, such as labels, as shall be described more fully below. The node systems 18a, 18b, 18c are preferably connected to a network 20, such as the Internet, so that the data collected may be shared, processed, e.g., to constitute a searchable database and stored via a server system 22 having a data processor 24 (a computer programmed with data processing/database software), non-volatile data storage 26 and conventional output 28, 30 and input 32 devices, by which the server 22 is maintained and the data collected by the server 22 is viewed and otherwise used. One or more subscriber systems 34 may use the network to obtain data from the server 22 and/or node systems 18a-18c. While the Internet has been identified as a suitable network 20,

other suitable communications networks would include: cellular, satellite, Intranets, WANs, cable and fiber optic networks.

Figure 2 shows a node system 18a for recording and sharing data concerning a commodity or article, e.g., 14a. Typically, the node system 18a would include at least one data input device 36, e.g., a barcode reader and/or keyboard, for receiving observed data 38 and/or data that was previously recorded on media 40, e.g., a barcode, such data previously recorded on media 40 being physically associated with the article 14a. A computer 42, e.g., in the form of a PC or handheld may be used to receive the data 38, 40 for transmission to the network 20, via a network link 44, such as a modem. If the data input device 36 is a PDA, cell phone, or other wireless device, then a computer 42 may or may not be necessary, since such devices now have the capability to connect directly to the Internet 20, via a wireless connection, e.g., radio transmission. The computer 42 may produce data output displayed, e.g., on a monitor and/or recorded on media 46, such as a 2D barcode label, barcode or data stick and/or record the data in local data storage 48. Because commodities, 12a, 12b, 12c and environments, e.g. 14a, 14b, 14c vary widely, each node system 18a, 18b, 18c may be similarly varied as to hardware and software components, as well as in functionality. For example, in the farm environment 14a depicted in Figure 1, a steer 12a that is ready for market has many attributes of interest, such as age, breed, weight, source, appearance, veterinary record, feed history, etc. These attributes may be purely observed data 38 or may have been previously recorded data 40, recorded on some media, such as an Electronic Identification Tag (EID) tag, Radio Frequency Identification (RFID), color-coded image, barcode or 2D barcode label. In the farm environment 14a, a steer 12a

would typically have an EID tag fastened to it at birth or soon after. The EID tag would record owner information, birth date, breed, identification number, etc. A node system 18a in the cattle breeding farm environment 14a may include an EID tag reader as one of the data input devices 36. The data "written" on the EID tag would
5 be an example of recorded data on media 40.

Continuing with this example, in addition to the recorded data on media 40, it would be expected that additional new data, i.e., observed data 38 such as current weight, health, age, etc. would be of interest to the overall process of tracking and describing
10 the steer 12a in the farm environment 14a. The additional observed data, 38 can be captured and recorded by various additional data input devices 36. The age of the animal may be manually entered by a keyboard; the weight of the animal may be ascertained by weighing the animal on a conventional scale and keying in the results, or directly inputting digital weight data into a computer. A photograph of the
15 animal may be captured by a digital camera and downloaded to a PC or obtained by a cell phone or a PDA. The capability of digital cameras and cell phones to capture images in digital form allows these devices to scan or "read" a digitally encoded label, such as a barcode or 2D barcode. This image data may then be communicated via a wire connection (e.g., a USB cable) or a wireless connection
20 (e.g., radio transmission to a local antenna in a local cell of a cellular phone network) to a computer with decoding software for decoding or simply for storage as image data for subsequent retrieval and use. A cellular phone may be used to establish an Internet connection to the website associated with the server system 22. Image data captured by the cell phone can then be sent to the server system 22 for decoding
25 and/or storage in the database if the cell phone or PDA does not have label

decoding software. While the foregoing example utilizes remote decoding, in an alternative embodiment, a cell phone and/or PDA could be programmed to provide on-board decoding. The present invention therefore encompasses numerous variations with regard to data input devices 36, including keyboard, mouse, barcode scanner, PDA, handheld computer, cell phone, EID tag reader, RFID reader, 2D
5 barcode label reader, digital scale, magnetic card reader, digital camera and other conventional transducers, readers, scanners and apparatus for entering data.

Similarly, observed data 38 would include any data concerning the present state of
10 the commodity or item being tracked. In the case of a steer 12a, this will include the time and location that the data is entered, a current picture of the animal, a prior picture, the owner, EID tag number, animal name, date of birth, gender, brand or tattoo, type, breed class, age, medical history, pedigree, weight, weighing date, size and color. Besides the foregoing objective data, certain data in the form of expert
15 judgment or scoring may be entered in terms of a numerical score or other conventional classifying scheme along with the expert's identification. For a steer 12a, this scoring data may include: body conditioning, locomotion, hoof condition, lameness, longevity, udder, mouth, body frame and reproductive condition.

20 Recorded data on media 40 would include printed textural material, barcodes, 2D barcode labels, Data Matrix labels, data recorded in magnetic media, such as CDs, magnetic sticks, strips and discs, EID tags, RFIDs, ROM chips, and any other conventional data recording media.

Besides sharing the data about the commodity 12a with the server 22 and any subscribers 34 and/or other node systems 18b, 18c, node system 18a may also generate data output recorded on media 46, such as by overwriting an EID tag or printing a barcode or a 2D barcode label. In this manner, the data received by the data input devices 36, including observed data 38 and recorded data on media 40 may be selectively reproduced by the data output device(s) 45 on the data output recorded on media 46. For example, the birth date, breed and ownership data retrieved from an EID tag may be merged with the weight, health and feed history data keyed into a node system 18a computer 42 to produce a 2D barcode label that records the entirety of this data and is readable by other persons and systems who encounter the 2D barcode label in the future and who may or may not be participants in the data tracking and labeling system 10. That is, the 2D barcode label may be read by a stand-alone 2D barcode label reader system (that has been configured properly and given the appropriate access and permissions, if applicable) independent from the data tracking and labeling system 10.

Given the foregoing, it can be appreciated that the system 10 enables the recording of data concerning a commodity, e.g., 12a as it is moved and processed to assume different states in different places over time. Having collected and stored the data in a database 26, the system 10 can readily generate reports concerning the commodity, e.g., 12a via conventional server and database processing software.

The tracking of a commodity, e.g., 12a is facilitated by utilizing a data field or fields representing time (month, day, year, hour, minute) and geographic location in terms of latitude, longitude, and elevation. Geographic location may also be specified by

conventional addressing information (station, building number, entity name, street address, town, country, zip code). This time and location information establishes when and where a particular set of data pertaining to a commodity is entered. For example, a data record collected on steer 12a at farm 14a may be associated/tagged/identified by a location field specifying the location of the farm 14a and a field specifying the time when the data was entered. By associating data concerning the commodity with the place and time of its recordation, the system can maintain a chronologically and geographically ordered, site-specific record of the history of the commodity 12a, 12b, 12c through its various stages of processing states in various environments 14a, 14b, 14c. The following is an exemplary field structure for recording geographic location:

Country	State	Latitude	County	Longitude
USA	Florida		Sarasota	
011	F28	N272957	45S	W822771
3 digits	3 digits	7 digits	3 digits	7 digits

The elevation above sea level can also be incorporated into the foregoing data structure to discern locations in the same building but on different floors. It should be noted that modern satellite GPS systems enable locations on the surface of the earth to be specified with precision, such that latitude and longitude coordinates can be used to locate a position to a high degree of precision and at a high resolution. In this manner, data captured on a steer in the field can be discerned from data collected hours later in a barn on the same farm via latitude and longitude coordinates.

Figure 3 shows a 2D barcode label 50 which may be used with the tracking and labeling system 10. The 2D barcode label 50 may be generated by printing and read by a CCD camera. They have a high data density permitting a large volume of data to be stored in a small area. The foregoing features permit a single 2D barcode label 50 to store the entire history of a product 12a, 12b, 12c. Accordingly, a package of meat 12c in a supermarket 14c may have a 2D barcode label 50 which contains all the data captured at the farm 14a, meat processing plant 14b and store 14c concerning the steer 12a and meat products 12b from which the package 14c was generated. As shall be described below, this is an attribute of the tracking and labeling system 10. By way of further example, a 2D barcode label 50 for olive oil tracked by the tracking and labeling system 10 may have the following format:

[http://www.scoringsystem.com/sample vegetable.html](http://www.scoringsystem.com/sample_vegetable.html)

OLIVE OIL 1234567890 70670011101 OLIVE OIL 1.29 8.5 FL. OZ.
24
NA NA DAVINCI ITALY WORLD FINER FOODS INC.
UNK LOT L 253U0

Labels using PDF-417 symbols can be utilized for the present invention. Using the smallest recommended element size, PDF-417 symbols can encode data at a density of up to 1,144 characters/inch². PDF-14 technology is known to those skilled in the art of labeling.

Figure 3B shows a Data Matrix code label 150 which may be used with the tracking and labeling system 10 in a similar manner to the 2D barcode label 50 described above. The Data Matrix code label 150 is formed and interpreted according to technology that is publicly available in accordance with ISO standard, ISO/IEC 16022.

Figure 4 shows a plurality of node systems 18d, 18f, 18g in an exemplary tracking and labeling system 10. Note that there is some overlap between the embodiment of the tracking and labeling system 10 shown in Figure 4 and that previously described above in Figures 1-3. The numbering of common elements has been modified by changing the subscripts to indicate that Figure 4 depicts an exemplary embodiment of the present invention that has some variations from that previously described. Node system 18d includes EID (electronic identification device) reader 36d for reading EID tag 40d on livestock (commodity graphically illustrated by circle 12d).

10 The data retrieved from the EID reader 36d is received by computer 42d and posted to a network 20 for receipt and storage by server 22 (see Fig. 1). In addition to sharing the data retrieved from the tag 40d, the computer 42d induces a 2D barcode printer 45d to generate a 2D barcode label 46d, which is applied to commodity 12e (12d was changed to 12e to signify a change of state of the commodity at environment 14d. For simplicity, the commodity 12e retains its reference number after transfer to environment 14e, despite the fact that it is older and is in a new "post-shipping" state). The 2D barcode label 46d may contain the data retrieved from the EID tag 40d, as well as any data input by other data input devices (generically shown as element 36 in Fig. 2) present at environment 14d. The

15 commodity 12d is then shipped to environment 14e. At environment 14e, data concerning the commodity 12e is retrieved from the 2D barcode label 46d that has been shipped with commodity 12e from environment 14d, e.g., the identification number, owner identification number, owner address, breed information, etc. taken from EID tag 40d by EID reader 36d, combined with observed data, such as the

20 weight of the steer, its health condition, veterinary record, feed record, and age,

25

which has been entered into the computer 42d by keyboard entry. All this information was encoded on 2D barcode label 46d, which was then applied to the commodity 12d, for example, by attaching the label to the steer or to the shipping container in which the steer is shipped to environment 14e.

5

Upon reaching environment 14e, the 2D barcode label 46d applied to or otherwise physically associated with commodity 12e is read by 2D barcode reader 36e at environment 14e. This information is processed by the computer 42e and is combined with other information specific to environment 14e. As before, the data
10 collected at environment 14e may be conveyed to the server 22 via a network connection. In addition, the data present at environment 14e concerning commodity 12e may be combined with the data obtained from 2D barcode label 46d and encoded into a new 2D barcode label 46e printed out by a 2D barcode printer 45e. 2D barcode label 46e may then be applied to or otherwise physically associated with
15 the commodity 12f in its then existing state at environment 14e. For example, if a steer 12e had been processed into sides of beef in environment 14e, which is a meat processing plant, then the commodity 12f, a side of beef, would receive a 2D barcode label 46e appropriate for conveying all the historical data for that side of beef, as well as new data recorded at environment 14e, such as, its weight, grade,
20 inspector, identification number and the results of bacteriological testing, etc. Accordingly, 2D barcode label 46e that is applied to a side of beef 12f includes all the data pertaining to that commodity throughout its processing in environments 14d and 14e, and therefore reflects the complete data set pertaining to that commodity up to that point in time. In addition, the server system 22 also has collected and
25 stored the data pertaining to this commodity at each stage in its processing history.

Alternatively, the 2D barcode label 46e (or other label, such as a written language label or barcode) can contain only a subset of the entire data set pertaining to the commodity. In one embodiment of the invention, the label has the internet address of the server 22 and at least one item of data that can serve to identify the commodity for retrieval of its historical data from the database 26.

The commodity 12f with 2D barcode label 46e is then transported to environment 14f, which may, for example, be a retail store, for further processing. Upon arrival, the commodity 12f and associated 2D barcode label is read by the 2D barcode reader 36f₁, and the associated data is fed into computer 42f. The computer 42f also receives data entered by other data input apparatus 36 (see figure 2) that would be applicable to a retail environment. For example, an inspector may examine each side of beef 12f that is received at the retail store 14f to ascertain that the meat has survived shipment in good condition and make note of its condition by entering that data into the computer 42f by means of a keyboard. The retail store 14f may also weigh the side of beef 12f and may spot-check it to test for contaminants. The processing of the commodity 12f at environment 14f may include processing of the side of beef 12f into consumer-sized cuts of meat 12g. Accordingly, the commodity 12f is converted into a different form 12g, which is weighed by scale 36f₂ and may also be graded by fat content, priced and otherwise categorized. This additional data may be entered into the computer 42f and shared with the server 22 by way of the network connection (see figure 1). In addition, a 2D barcode printer 45f₁ may produce a 2D barcode label 46f which expresses and contains some or all the historical data pertaining to the particular cuts of meat 12g to which it is applied. The

computer may also generate other outputs such as UPC labels via a UPC label printer 45f.

Accordingly, a commodity, for example 12d, has been tracked and labeled by the tracking and labeling system 10 throughout its processing history, at various locations and in various states of processing, namely, 12d, 12e, 12f and 12g. All the data associated with the commodity and its various states is stored on the server 22 and is also stored and represented at every state by a label, for example, a 2D barcode label, which is physically associated with the commodity. As a result, there are two alternative means to access the history of the commodity, e.g., 12g at any stage in its processing life, namely, by reading the label, e.g. 46f, that is associated with the commodity 12g and/or by accessing the data that has been stored on the server system 22 (see Figure 1). The tracking and labeling system 10 generates a database 26 and labels, e.g., 46d, to retain tracking history by accumulating, recording, storing, and reporting object processing and other data for a wide variety of objects and scenarios. All these applications have the common need to identify members of an object class at each processing state, e.g. 12d, so that specific detailed information about the processing at that stage/environment 14d and earlier stages can be captured, combined, accessed and preserved. In so doing, what had begun as essentially "empty" record for the object 12d in its initial, unprocessed form becomes a completed historical record for each of the subsequent states and/or constituents of a compound object as it is processed and labeled at each environment 14d-14f, from start to finish.

To build the historical processing record in accordance with an embodiment of the present invention using 2D symbology, each processing environment 14e-14g reads the label, e.g., 14d on the input object, e.g., 12e to that environment, e.g. 14d, updates the label's record with new information, and creates a quantity of labels, e.g., 46e to identify each output object, e.g. 12f for transfer to the next environment 14f. The first record on each label, e.g., 46d may be a standard key data element common to all states 12d-12g and processing environments 14d-14f, corresponding to the URL (Internet web address) for the server 22. This enables an authorized user, e.g., 34 to access the online database 26 (by providing the proper login information) to read and update the database 26 in real time. In this manner, each label, e.g., 46d, need not contain the entire product history, but instead, may function as a key to access the history on the database 26. If the relevant data is encoded on the label, this data is available to a properly equipped user (who may be required to provide authorization) without an online connection, enabling the user to obtain updated information offline in read-only mode.

When the commodity has completed all processing, and the data record(s) is/are finalized in the database and in the form of a label on a product, this data can be archived for a specified storage period and accessed for reporting the history of the object, its origin and processing, as required. Reading the label on the finished product (online or offline) allows the user to retrieve and report the final source information and processing history on each individual item.

Data compaction and error correction techniques for several popular 2D symbologies satisfy the requirements of this application. The ability to control the parameters that

determine size, shape, data content and reading characteristics of the label at each stage, as the object history is accumulated and capacity requirements change, makes this technology particularly suited to this application. This is especially important in view of: the range of severe environmental conditions; variety of object sources, sizes, and characteristics; number and type of processing stages; and other special conditions that make each application and object type unique. Data integrity and security are central features of this technology, arising from the mathematics and numerous programming options that are essential to 2D symbology.

5

10 Assuming that at least one and potentially numerous, records are entered into the database pertaining to the various states and processing that a commodity has undergone at least one and possibly numerous environments, the tracking of the commodity through its various states and locations during processing are readily obtainable as a written or viewable report presented on the screen of a user's

15 computer. For example, if a person returns a cut of meat to the retail store in which they purchased it, complaining that it is in some manner unacceptable, such that it becomes of interest to determine exactly where the meat originated from, this task can be performed by the tracking and labeling system 10 of the present invention. In the first instance, the consumer preferably returns the meat in its original packaging,

20 which would include the label prepared for the packaging by the present invention. The label would be readable by, e.g., a 2D barcode label reader to ascertain the data associated with the package of meat. This data can be read directly into a computer. Assuming that the retail store is a licensed user or otherwise has access to the tracking and labeling system 10, which is secured against unauthorized use and

25 access by unauthorized users, the entire history of the meat can be retrieved from

the database 26 by the server 22 using conventional database techniques, e.g., as are applied to process query requests to a relational database. For example, the tracking and labeling system 10 may maintain tables of all data transactions received from all specific geographic locations (corresponding to sites of specific processing functions and/or specific responsible parties in the production chain) These tables can be linked by source and destination fields, such that each record entry signifying a data entry transaction typically associated with a state change for the commodity (some form of processing) will indicate the geographic location and time when the entry is made, the geographic location from which the commodity was received and optionally, the target geographic location to which the commodity is to be sent. Given a particular reference record, e.g., that encoded on the questionable package of meat in the consumers hands, conventional database software can readily step back through all the linked records in the various relevant tables in the database corresponding to the various processing points to find all processing points that the commodity has experienced from the beginning. If the commodity is found to be defective in some way which indicates that like commodities that share some processing point could be a threat to health or welfare in some manner, then all commodities passing through that processing point can be identified and extracted from the database for any specified time period based upon a suitable query. The present location of all questionable commodities can then be ascertained, such that notification of the present possessors of the commodities can be undertaken and a product freeze or recall initiated with great speed. One can readily envision the same facilities employed to aid in tracing back a source of contamination for the purpose of diagnosis by means of identifying the various processing points that are the potential source of contamination and testing each of those source in turn.

While it is advantageous to have a labeled end product to initiate the querying process of the database 26 to track a specific product, it is not a necessary prerequisite. More specifically, the database 26 may be queried by an authorized user to search for any number and combination of criteria, e.g., "extract and display
5 all sources of pork chops delivered to XYZ store in the 2nd and 3rd weeks of May, 2003". It is also likely that as part of modern retail inventory control systems, the immediate source of the product can be identified, thus providing the starting information from which the database can be queried.

10 Figure 5 shows sample data for a steer 12a as it would appear on a data entry/display screen 52 of a node computer 42 for entering and displaying data pertaining to a commodity by tracking and labeling system 10 of the present invention. "PIDC" refers to the site-specific geographic location code.

15 The identity of the record keeper(s) 54a-e may be used as a hyperlink to the web page of the record keeper such that if the node system, e.g., 18a is online, double clicking on the link will connect the user to that website. Note that the PIDC codes 56a-d are the same, indicating multiple data entries have been made at the same place. PIDC 56e is different, indicating that the tracked commodity was moved to
20 another place.

Since the number of processing steps and data entry transactions will vary from commodity to commodity (and even between the specific individual commodities of a
25 group of commodities of the same class), the number of displayed data entries at

specific PIDC's 56a-e, and dates, recorded by record keepers 54a-e will vary. For example, there may be five entries or five hundred or any other number.

While the present invention has been explained above in terms of the processing of a steer, it may be used for tracking and labeling any product, such as, seeds, plants, bulbs, vegetables, fruits, vineyard crops, wines and beer hops. As noted above, the present invention lends itself to maintaining and sharing performance and quality scoring data pertaining to livestock, e.g., horses, dairy cows, beef cattle, goats, etc. As applied to wine, the following data would be included as being potentially relevant: photographs of the grapes, the wine, the vineyard, the region, the identification of the vineyard owner, location, the name of the wine, the identification of the harvester, a general description of the wine, alcohol content, whether it is drinkable by diabetics, sulfur, tannin and acid content, drinking temperature, price class, etc.

15

While a human being should never be considered a commodity, certain skills, such as athletic abilities, as exemplified by sports performance records, are sometimes viewed as commodities and could be recorded and tracked by the present invention. In the case of athletic (soccer) score/performance recording and tracking, the following data might be entered into the tracking and labeling system 10: name, age, hometown, citizenship, current club/ team, height, weight, shoe size, years playing soccer, gender, age, marital status, children, player biography, current club/team, current field position, current jersey number, previous position, date started in this club/team, under contract, if yes, date of contract termination, previous club/team, previous profession or grade, technique, play on, number of goals (current team),

25

number of goals (lifetime), goals on target, 100 meter time, and number of soccer awards.

The present invention 10 can be utilized for tracking and controlling the admittance
5 of persons into secure sites, such as office buildings, construction sites and sport
stadiums. For example, an employee may be issued an access card (recorded data
on media 40) bearing that person's specific information encoded in e.g., 2D barcode
50 or Data Matrix 150 form. The card may have a photo ID. By scanning the card at
a secure entrance point to the secure site, information pertaining to the employee
10 may be verified, captured and stored by the system 10. For example, the fact that a
particular employee has entered a specific entry point at a certain time is noted for
timekeeping, scheduling and/or security purposes.

Similarly, access to public facilities, such as sports arenas or concerts can be
15 monitored and controlled with an access card encoded with information concerning
the bearer, such as their physical attributes, personal password data, photo ID, etc.,
such information providing security personnel with means to verify the identity of
persons for security and marketing purposes. As in embodiments described above,
the data encoded and carried by the tracked individual may be updated by the node
20 system, e.g., 18e by printing a new 2D barcode label, e.g., to decrement the number
of future admissions of a pass permitting a predetermined number of admissions.

While the foregoing exemplary uses of the present invention pertain to individual
commodity units, such as a steer 12a, the present invention may also be utilized for
25 manufactured, fabricated and compound products. For example, a manufacturer of

frozen pizzas may utilize the tracking and labeling system 10 to enter the product information concerning all products (such as, flour, oil, tomato sauce and cheese) entering his factory that go into a batch of pizzas. The source-of-content information may be stored on the server 22 and may also be used to print a label which can be
5 placed on the packaging of the finished pizza.

The present invention, therefore, provides a system for data collection, storage sharing, reporting and labeling. The system can handle any type of data concerning any type of tangible commodity or any other entity or intangible data fields
10 throughout its entire history, providing a means for tracking individual and groups of tangible objects and intangible items (including data) and identifying all environments, processing and changes of state they have undergone.

Claims:

1. A system (10) for collecting and recording data (38) on an item (12a) as the item experiences changes in state over time, with first data input means (36)
5 for capturing a first set of data (38) pertaining to a first state of the item (12a) in a first environment (14a), said system being characterized by second data input means (36) for capturing a second set of data (38) pertaining to a second state of the item (12b) in a second environment (14b); data processing means (22) for storing said first and second sets of data (38) in a
10 database (26) and selectively accessing said first and second sets of data (38) from said database (26); and communication means (20) for communicating said first and second sets of data (38) to said data processing means (22).
2. The system (10) of Claim 1, further characterized by transportable data
15 storage means (40) for receiving and storing a third set of data (38), said transportable data storage means (40) physically accompanying the item (12a) for a selected length of time.
3. The system (10) of Claim 2, further characterized by a third data input means
20 (36) for reading said transportable data storage means (40) and accessing said third set of data (38).
4. The system (10) of Claim 3, further characterized by a first output means (45) for writing a fourth set of data (38) to said transportable data storage means (40, 46).

5. The system (10) of Claim 3, characterized in that said first and second sets of data (38) at least partially include data (38) observed about the item in the first (14a) and second (14b) environments, respectively.
6. The system (10) of Claim 4, characterized in that said third set of data (38) is captured by at least one of said first and second data input means (36).
7. The system (10) of Claim 4, characterized in that a portion of at least one of said first and second sets of data (38) is included in said fourth set of data (38).
8. The system (10) of Claim 7, characterized in that a portion of said third set of data (38) is included in said fourth set of data (38).
9. The system (10) of Claim 4, characterized in that said first output means (45) is selected from the group consisting of: a 2D barcode label printer, a Data Matrix label printer, a barcode label printer, a text label printer, a magnetic card writer, a magnetic stick writer, a floppy disk writer, and a CD writer.
10. The system (10) of Claim 3, characterized in that said third data input means (36) is selected from the group consisting of: a 2D barcode label reader, a Data Matrix label reader, a CCD camera, a barcode reader, a magnetic stripe reader, a magnetic card reader, an EID tag reader, and RFID reader, a color-coded image reader, a cell phone, a magnetic stick reader, a CD reader, a floppy disk reader and an optical character reader.
11. The system (10) of Claim 2, characterized in that said transportable data storage means (40) is selected from the group consisting of: a 2D barcode label, a barcode label, an EID tag, an RFID, a color-coded image, a Data

Matrix label, a magnetic stripe, a magnetic card, a magnetic stick, a ROM chip, a text label, a floppy disk and a CD disk.

12. The system (10) of Claim 1, characterized in that said first data input means (36) is selected from the group consisting of: a Personal Digital Assistant (PDA), a cell phone, a digital camera, a handheld computer, a personal computer with keyboard, and a weighing scale.
13. The system (10) of Claim 1, characterized in that said data processing means (22) includes a computer (24) programmed with database management software.
14. The system (10) of Claim 1, characterized in that said communications means (20) includes a network and said data processing means (22) is connected to said network.
15. The system (10) of Claim 14, characterized in that said network (20) is the internet.
16. A method for tracking an item (12a) as it changes state (12a, 12b, 12c) and environment (14a, 14b, 14c) over time by:
- (A) collecting and recording a first set of data (38) pertaining to an item (12a) in a first state in a first environment (14a); said method being characterized by
 - (B) changing at least one of the first state (12a) and the first environment (14a) of the item (12a) to a second state (12b) and a second environment (14b);

- (C) collecting and recording a second set of data (38) pertaining to the item (12a, 12b);
- (D) communicating the first and second sets of data (38) to a data processing system (22);
- 5 (E) storing the first and second sets of data in a database (26) of the data processing system (22); and
- (F) Selectively accessing at least a portion of the first and second data (38) sets.

17. The method of Claim 16, further characterized by the step of reading a third
10 set of data (38) from first media (40, 50) physically accompanying the item (12a).

18. The method of Claim 17, further characterized by the step of writing a fourth
set of data (38) on second media (40, 50), said second media (40, 50) then
being physically associated with the item (12a) to accompany the item (12a)
15 for further changes in environment (14a, 14b).

19. The method of Claim 16 characterized in that said step (A) of collecting
includes capturing observed data (38) concerning the item (12a) when the
item (12a) is in the first environment (14a).

20. The method of Claim 18, characterized in that the step (A) of collecting
20 includes capturing observed data (38) concerning the item (12a) when the
item (12a) is in the first environment (14a), the step of communicating
includes transmitting the first set of data (38) over the internet (20) to the data

processing system (22), the step of storing includes entering the first set of data (38) into a database (26) on the data processing system (22) and the step of selectively accessing includes submitting a query via database management software to select data (38) from the database (26) in response to a user-defined criterion.

5

21. The method of Claim 16, characterized in that said step of accessing is conducted in the course of identifying the source of a health threat associated with the item (12a, 12b, 12c).

22. The method of Claim 21, characterized in that the item (12a) is a food product.

10

23. The method of Claim 16, characterized in that the item (12c) is a component of a composite item (12a, 12b) having additional compositional items (12b, 12c) and further comprising the steps of tracking the additional compositional items (12b, 12c) and the composite item (12a, 12b) by performing the steps (A) through (F) for each.

15

24. The method of Claim 16, characterized in that the item (12a) is the performance record of an athlete.

25. An item tracking system (10) for collecting and recording data (38) on an item (12a) as the item (12a) experiences changes in state over time, said item tracking system (10) being characterized by:

20

(A) a server computer (22) with data processing capability and a database (26), said server computer (22) connected to the internet (20);

- (B) a plurality of geographically separated node systems (18a, 18b, 18c) connectable to the internet (20) , each of said plurality of node systems (18a, 18b, 18c) capable of capturing data (38) concerning the item (12a) at various times and states of (22) the item (12a, 12b, 12c) and communicating the captured data (38) to the server (22) via the internet (20) for storage in said database (26), said server computer (22) capable of generating a history of said item (12a) from the data (38) captured and sent to said server (22) from said plurality of node systems (18a, 18b, 18c).
- 5
- 10 26. The tracking system (10) of Claim 25, further characterized by a label reader (36f_i) associated with at least a portion of said plurality of node systems (18e, 18f), said label reader (36e, 36f_i) capable of reading labels (46d, 46e) physically associated with the item (12e, 12f) to obtain label data (40) and communicating that label data (40) to said server (22).
- 15 27. The tracking system (10) of Claim 26, further characterized by a label printer (45d, 45e, 45f₁, 45f₂), said label printer (45d, 45e, 45f₁, 45f₂) printing labels representative of data (38) concerning the item (12e) and thereby permitting the item (12e) to be relabeled with data (38) that reflects an up-to-date product history.
- 20 28. The tracking system (10) of Claim 27, characterized in that the type of label (46d, 46e, 46f) produced by said label printer (45d, 45e, 45f₁, 45f₂) is selected from the group consisting of: 2D barcode label, Data Matrix label, barcode label and text label.

29. The tracking system (10) of Claim 27, characterized in that the label (46d, 46e, 46f,) printed by said label printer (45d, 45e, 45f₁, 45f₂) includes the internet address of said server (22) and identification data for identifying the item (12a, 12b, 12c).
- 5 30. The tracking system (10) of Claim 25, characterized in that the captured data (38) on the item (12a, 12b, 12c) is communicated to said server (22) along with data (38) indicative of the geographic location of the item and time.
31. The tracking system (10) of Claim 30, wherein said at least one of said plurality of node systems (18a, 18b, 18c) includes a cell phone.
- 10 32. The tracking system (10) of Claim 31, wherein said cell phone has imaging capability.
33. The tracking system (10) of Claim 32, wherein said cell phone is capable of capturing and transmitting label image data over the Internet for subsequent processing by a remote computer.
- 15 34. The system (10) of Claim 1, further including display means (30) associated with at least one of said first data input means and said second data input means for displaying at least one of said first set of data and said second set of data.
- 20 35. The system (10) of Claim 34, wherein at least one of said first set of data (38) and said second set (38) of data includes identification data (56a-56e) pertaining to said first environment (14a, 14b, 14c) and said second environment (14a, 14b, 14c), respectively.

36. The system (10) of Claim 35, wherein said identification data (56a-563) includes an internet address (54a) for connecting to a website associated with at least one of said first environment (14a, 14b, 14c) and said second environment (14a, 14b, 14c).
- 5 37. The system (10) of Claim 2, wherein said third set of data (38) is selectively composed of at least one of said first set of data (38) and said second set of data (38).
38. The system of Claim 14, wherein said communication means (44) includes a wireless connection to the internet (20).
- 10 39. The method of Claim 16, wherein said steps (A) and (C) of collecting and recording pertain to identification of information (38) for a person.
40. The method of Claim 39, wherein said identification information (38) is utilized to track a person for the purposes of at least one of scheduling, security and timekeeping.
- 15 41. The method of Claim 16, wherein said steps (A) and (C) of collecting and recording pertain to access data (38) controlling the access of a person to a secure site.
42. The method of Claim 41, wherein at least one of said steps (A) and (C) of collecting includes retrieving data (38, 40) from an access token (40, 40d, 46d-46f) carried by a person.
- 20 43. The method of Claim 42, wherein said access token (40, 40d, 46d-46f) is in the form of an ID card bearing digitally recorded data (38, 40).

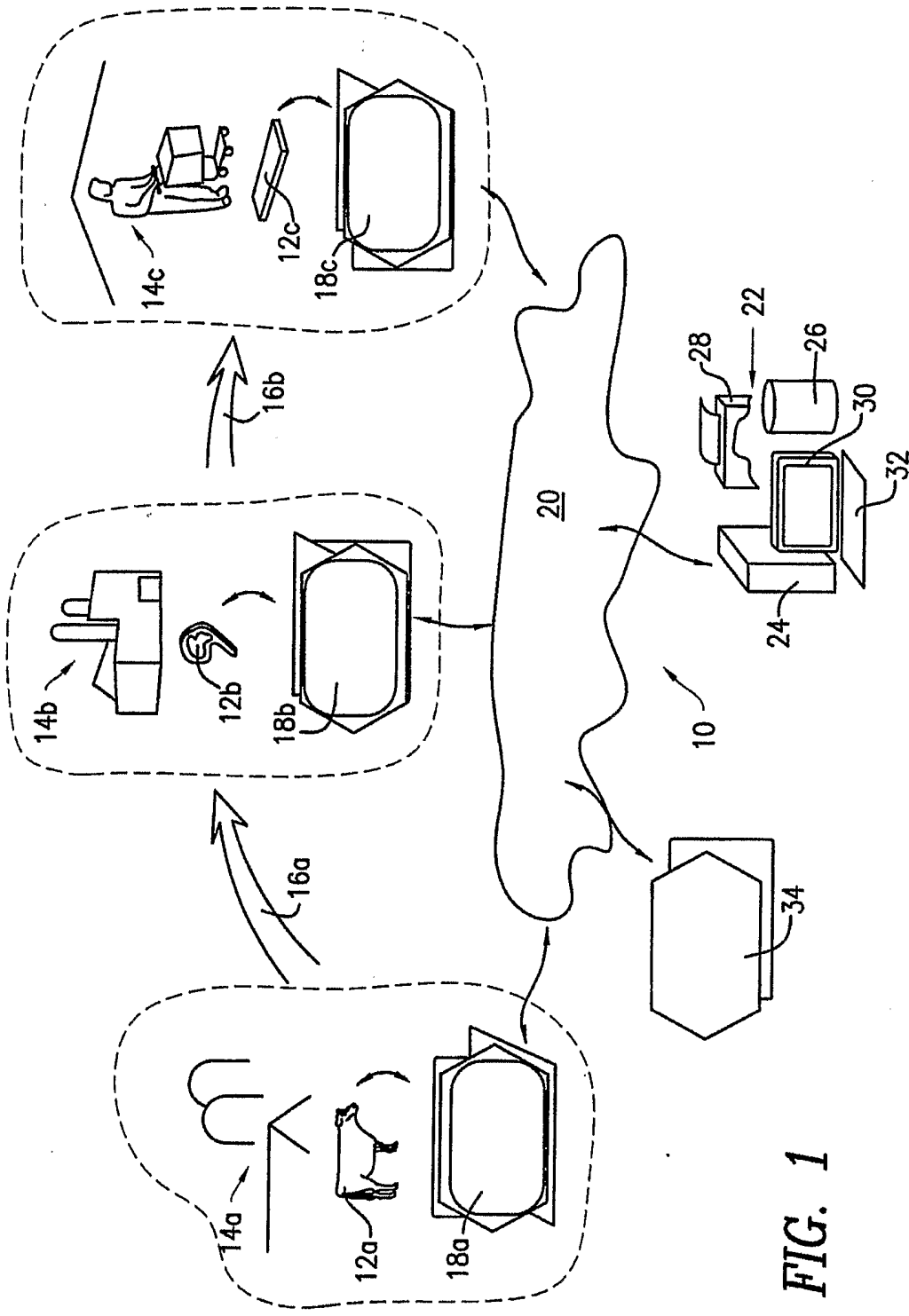

FIG. 1

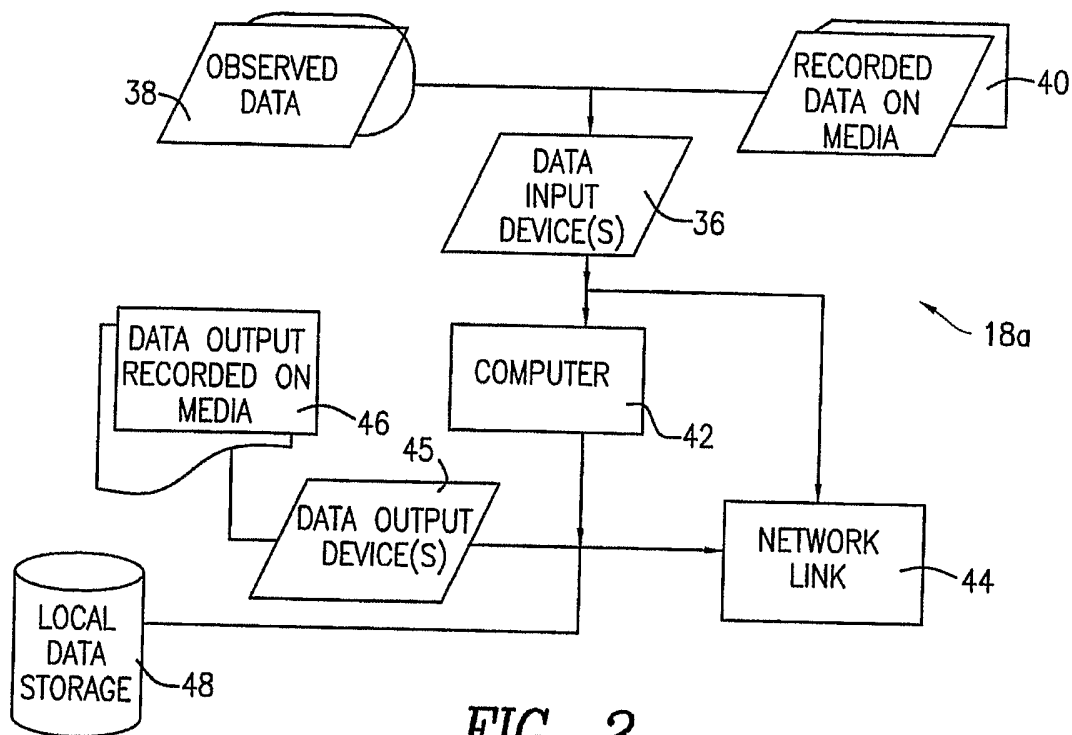

FIG. 2

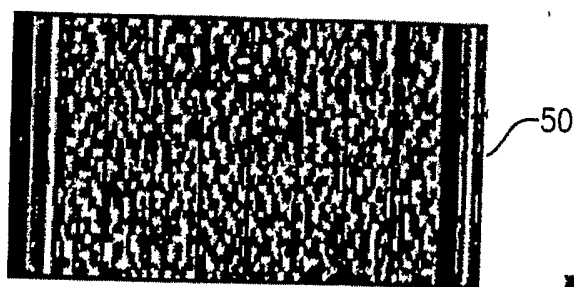

FIG. 3A

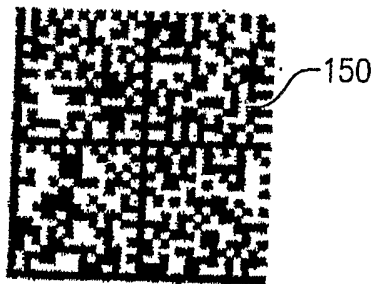

FIG. 3B

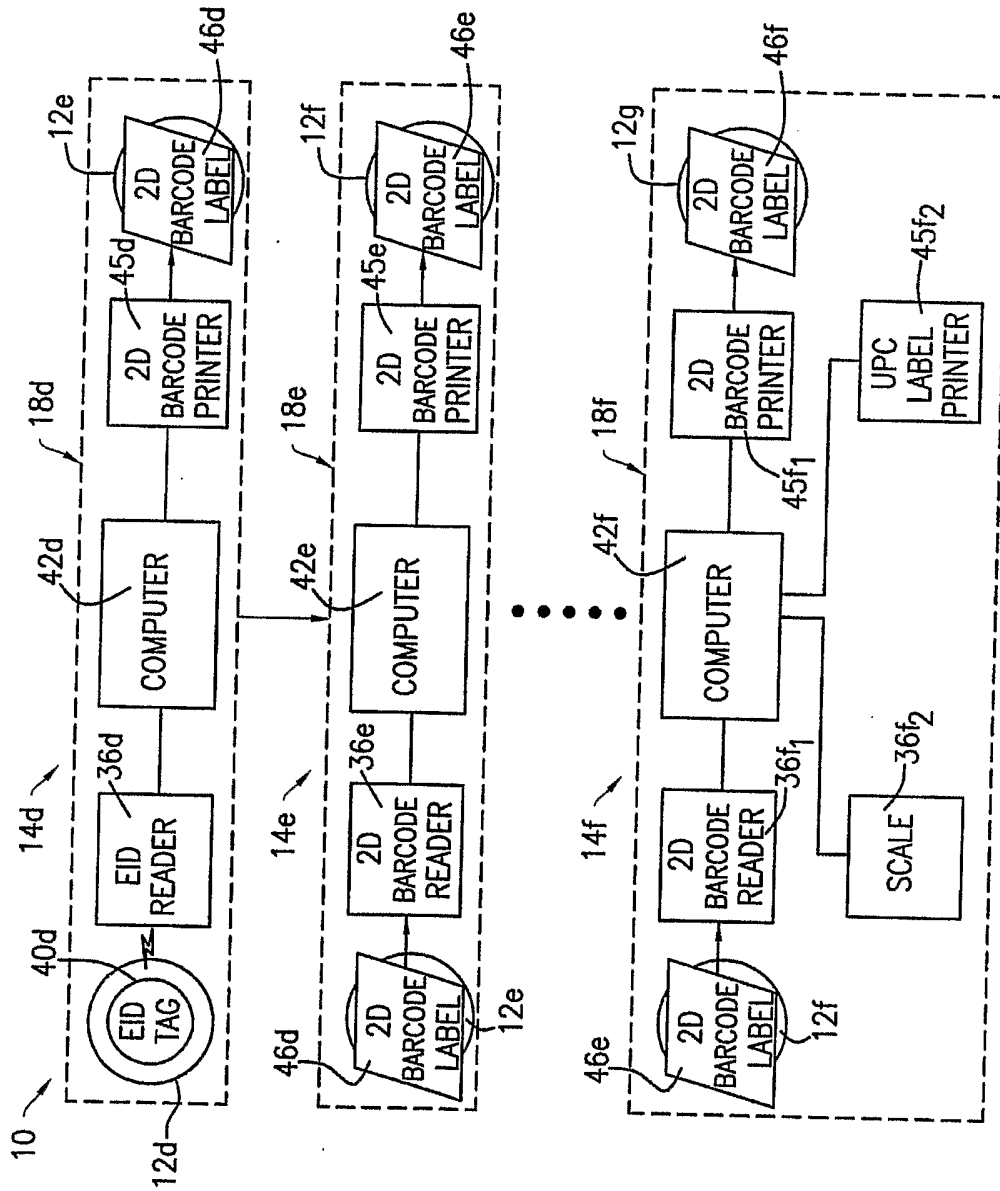

FIG. 4

SCORING SYSTEM: SAMPLE DATA FOR A HEAD OF CATTLE

SAMPLE SCORING DATA:

56a	PIDC	011F28N27295745SW8277100	D	02/10/2002	RECORD KEEPER1 ID	54a
56b	PIDC	011F28N27295745SW8277100	D	06/10/2003	RECORD KEEPER1 ID	54b
56c	PIDC	011F28N27295745SW8277100	D	07/12/2002	RECORD KEEPER1 ID	54c
56d	PIDC	011F28N27295745SW8277100	D	07/13/2002	RECORD KEEPER1 ID	54d
56e	PIDC	011F28N28326536BW8144631	D	07/21/2002	RECORD KEEPER2 ID	54e

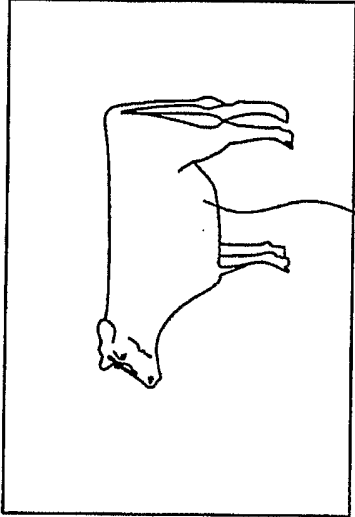
GENERAL INFORMATION	
LAST UPDATE	07/15/2000
	
PREVIOUS PICTURE: N/A OWNER: SAMPLE OWNER ELECTRONIC TAG: 985120012132782 ANIMAL NAME: EXAMPLE2 DATE OF BIRTH GENDER: MALE TAG BRAND/TATTOO: 1111 TYPE BEEF BREED CLASS WHITE FACE BLACK ANGUS AGE: 10 WEIGHT: 970lbs WEIGHT DATE: 07/15/2000 SIZE: LARGE COLOR: BLACK	

FIG. 5

52