

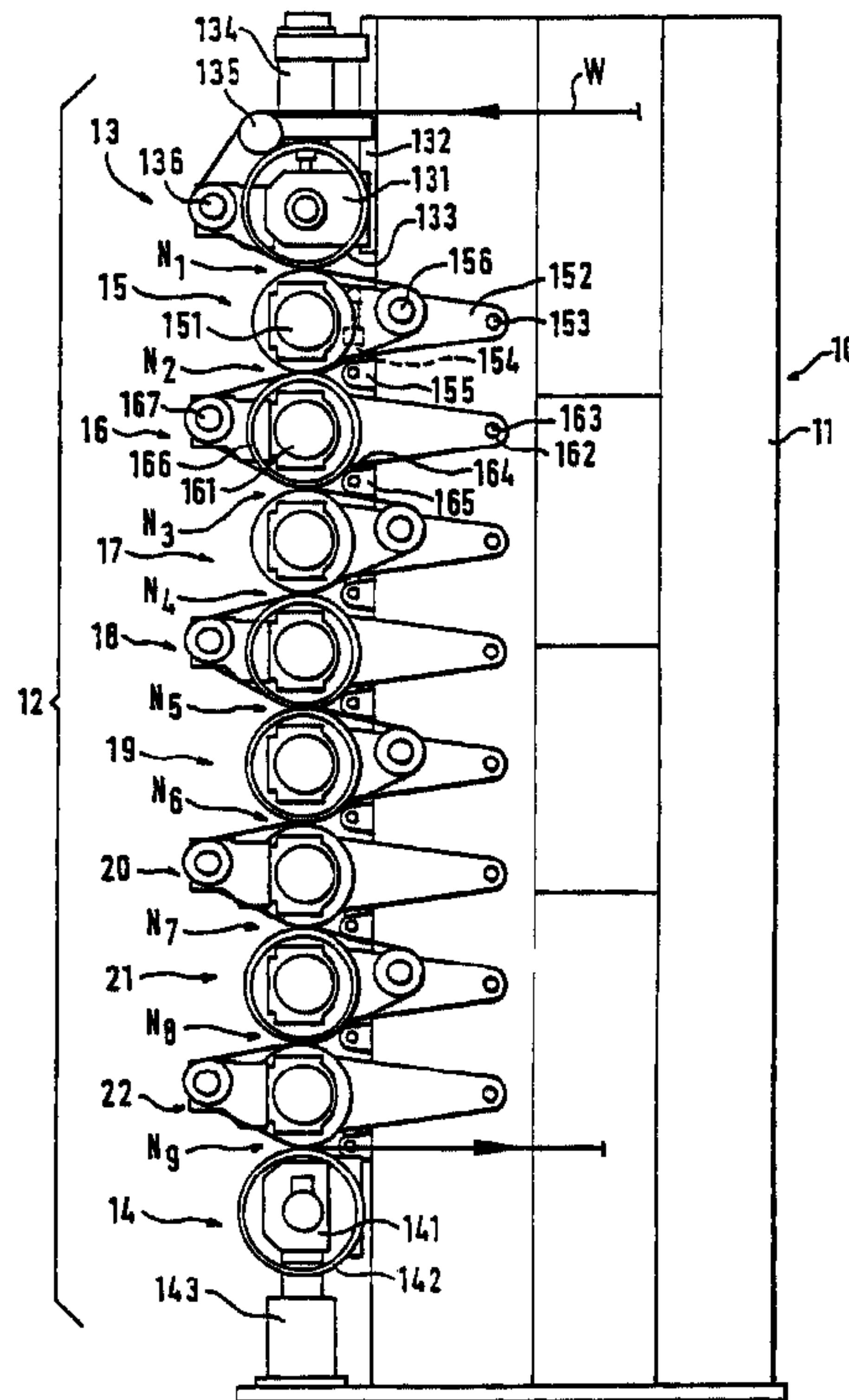

(22) Date de dépôt/Filing Date: 1994/11/23
 (41) Mise à la disp. pub./Open to Public Insp.: 1995/06/01
 (45) Date de délivrance/Issue Date: 2005/05/17
 (62) Demande originale/Original Application: 2 154 479
 (30) Priorité/Priority: 1993/11/24 (935214) FI

(51) Cl.Int.⁷/Int.Cl.⁷ D21G 1/00
 (72) Inventeurs/Inventors:
 KOIVUKUNNAS, PEKKA, FI;
 LIPPONEN, JUHA, FI
 (73) Propriétaire/Owner:
 METSO PAPER, INC., FI
 (74) Agent: SIM & MCBURNEY

(54) Titre : PROCÉDE DE CALANDRAGE DE PAPIER OU D'UN MATERIAU EN BANDE SIMILAIRE ET CALANDREUSE PERMETTANT SA MISE EN OEUVRE
 (54) Title: METHOD IN THE CALENDERING OF PAPER OR OF AN EQUIVALENT WEB MATERIAL AND A CALENDER THAT MAKES USE OF THE METHOD



(57) Abrégé/Abstract:

The calender comprises a frame (11;11a), a variable-crown upper roll (13;13a), a variable-crown lower roll (14;14a) and two or more intermediate rolls (15...22;15a...22a) fitted between the upper (13;13a) and lower (14;14a) rolls. The upper, lower and intermediate rolls are arranged on the frame (11;11a) of the calender as a stack of rolls (12;12a) and being in nip contact with one another to form calendering nips (N1...N9) between the rolls. Hard- and soft-faced rolls are used on the intermediate rolls in which the form of the natural deflection line produced by their own gravity is substantially equal and the nip loads produced by the masses of the intermediate rolls and of the auxiliary equipment related to them are relieved.

Abstract of the Disclosure

The calender comprises a frame (11;11a), a variable-crown upper roll (13;13a), a variable-crown lower roll (14;14a) and two or more intermediate rolls (15...22;15a...22a) fitted between the upper (13;13a) and lower (14;14a) rolls. The upper, lower and intermediate rolls are arranged on the frame (11;11a) of the calender as a stack of rolls (12;12a) and being in nip contact with one another to form calendaring nips ($N_1...N_9$) between the rolls. Hard- and soft-faced rolls are used on the intermediate rolls in which the form of the natural deflection line produced by their own gravity is substantially equal and the nip loads produced by the masses of the intermediate rolls and of the auxiliary equipment related to them are relieved.

**METHOD IN THE CALENDERING OF A PAPER OR OF AN EQUIVALENT
WEB MATERIAL AND A CALENDER THAT MAKES USE OF THE METHOD**

This application is a division of copending Canadian Patent Application No. 2,154,479 filed November 23, 1994.

The invention concerns a method in the calendering of a paper or of an equivalent web material in a calender, wherein the web material to be calendered is passed through nips formed by a variable-crown upper roll, a variable-crown lower roll, and by intermediate rolls arranged between said upper and lower rolls, said rolls being arranged as a substantially vertical stack of rolls.

Further, the invention concerns a calender that makes use of the method, which calender comprises a variable-crown upper roll, a variable-crown lower roll, and a number of intermediate rolls fitted between the upper and lower rolls, said rolls being arranged on the frame of the calender as a substantially vertical stack of rolls and said rolls, placed one above the other, being in nip contact with one another.

The set of rolls in a conventional supercalender comprises a number of rolls, which have been arranged one above the other as a stack of rolls. The rolls placed one above the other are in nip contact with one another, and the paper or board web or equivalent to be calendered is arranged to run through the nips between the rolls.

The rolls in the set of rolls are journalled revolvingly on bearing housings, which are again attached normally to base parts that are fitted slidably on vertical guides provided in the frame of the calender. Further, the base parts are provided with backup parts, which are fitted on vertical lifting spindles provided in the frame of the calender. Thus, one function of the lifting spindles is to act as guides so as to keep the rolls in the set of rolls in the correct position. The bearing housings of the rolls in the set of rolls are not fixed rigidly to the frame of the calender, but the bearing housings

and, thus, also the rolls can move in the vertical direction. Since the masses of the bearing housings of the rolls and of the auxiliary equipment attached to same are quite large, in conventional supercalenders this produces the remarkable drawback that said masses of the bearing housings and of the auxiliary equipment attached to same produce distortions in the distributions of the linear loads in the nips. Thus, the linear load is not uniform in the nips, but there is a considerable deviation in the profile of linear loads at the ends of the nips. Since there is a number of rolls placed one above the other in the sets of rolls in super calenders, as was already stated above, this has the further consequence that the linear loads in the individual nips are cumulated and produce a considerably large error in the overall linear load. This defective distribution of linear load deteriorates the quality of the calendered paper or equivalent web material.

In view of solving the problem stated above, in the applicant's F1 Patent 81,633 of earlier date it is suggested that the set of rolls be provided with relief means, which are supported on the base parts of the rolls, on one hand, and on spindle nuts provided on the lifting spindle, on the other hand, so that, by means of said relief means, the distortions arising from the weight of the bearing housings of the rolls and of the auxiliary equipment attached to same, for example the take-out leading rolls, in the lateral areas of the profiles of linear loads between the rolls can be eliminated. Also, in conventional machine calenders, a solution is known in prior art in which the rolls of the machine calender are provided with a relief system, in particular with hydraulic relief cylinders, so as to eliminate the point loads arising from the bearing housings of rolls and from their auxiliary equipment. In machine calenders, it is easy to provide such relief means, because the rolls in the set of rolls in a machine calender are arranged by means of linkages mounted on the frame of the calender. The use of devices corresponding to those of machine calenders in supercalenders is, however, quite difficult because of the constantly varying diameters of the fibre rolls and because of the high number of rolls.

Owing to their construction described above, conventional supercalenders further involve a second remarkable drawback, which is related to the vertical movements of the rolls in the set of rolls. As was described above, the bearing housings of the rolls in the set of rolls are mounted on base parts, which move vertically along the guides provided in the frame of the calender. This second drawback is related to the friction at the guides, which friction is effective between said guides and the base parts. Thus, owing to the friction at the guides, the rolls in the set of rolls cannot move fully freely to be positioned vertically, which may produce disturbance in the operation of the calender, together with considerable local errors in the distributions of the linear loads. In order to eliminate the frictions at guides, in supercalenders, it might be possible to consider the use of the solution described above and commonly known from machine calenders, in which the rolls are fitted on the frame of the calender by the intermediate of linkages mounted on the frame. The use of such an arrangement in supercalenders is, however, limited by the fact that the set of rolls in a supercalender includes a number of fibre rolls, whose diameter may vary even considerably. Owing to the variation in the diameters of the rolls, in such a case, the rolls must be able to move considerably in the vertical direction. If the rolls were attached to the frame of the calender by the intermediate of linkages, in such a case, the vertical shifting of the rolls would also result in a considerable shift in the transverse direction.

In view of solving the problem described above, in the applicant's F1 Patent No. 83,346 of earlier date, an arrangement is suggested by whose means the frictions at guides can be eliminated and by whose means the axle-journal loads arising from the bearing housings of the rolls and from the auxiliary equipment in the set of rolls can

be relieved so as to straighten the distribution of linear load. In said F1 patent, this has been accomplished so that the base parts of the intermediate rolls in the stack of rolls in the calender are supported on the lifting spindles vertically displaceably by means of pressure-medium operated relief devices fitted between the base parts and the spindle nuts so as to relieve the axle-journal loads of the rolls, and that the bearing

housings of the intermediate rolls are attached to the base parts pivotally in relation to an articulation shaft parallel to the axial direction of the rolls, being supported on the base parts and/or on the frame of the calender by means of attenuation devices so as to equalize the forces arising from the movements of the nips between the rolls and to attenuate the vibrations of the rolls.

All of the solutions in accordance with the prior art described above involve the drawback that, in the supercalender, the nips are loaded by the gravity of the set of rolls itself, in which case the distribution of the linear loads from the upper nip to the lowest nip is substantially linearly increasing. This has the consequence that the linear load present in the lowest nip determines the loading capacity of the calender. Thus, the calender is dimensioned in accordance with the loading capacity of the lowest rolls. At the same time, some of the loading or calendaring potential of the upper nips remains unused. Attempts have been made to illustrate this in Fig. 1 in the drawing, wherein the stack of rolls in the calender is denoted with the reference numeral 1. The rectangle drawn alongside the stack of rolls and denoted with the reference I illustrates the calendaring potential of the calender, while the horizontal axis of the rectangle represents the linear loads in the nips in the stack of rolls 1. The shaded area in the rectangle, which is denoted with the reference A_1 , represents the range of linear loads employed in conventional solutions, and from this it can be noticed directly that the distribution of the linear loads from the upper nip to the lowest nip is substantially linearly increasing. The range of adjustability of the linear loads is quite narrow. The designations B_1 and C_1 mean those areas in the range of linear loads that remain fully unused in the prior-art solutions. Since the masses of the rolls in the set of rolls load the nips, regulation of the linear loads to the range B_1 is impossible, because high linear loads are unavoidably produced in the lower nips. Thus, running of matt grades with a conventional supercalender is quite difficult if the same machine is used for the production of glazed grades. On the other hand, the range C_1 remains unused, because the calender has been dimensioned in accordance with the loading capacity of the lowest rolls. Thus, a substantial proportion of the

loading capacity of the upper nips remains unused.

Earlier, attempts have been made to solve this considerable drawback involved in the prior art so that attempts have been made to increase the deficient loading of the upper nips by placing the supercalender in the horizontal plane or by dividing the stack of rolls in the calender into two roll stacks. In the case of horizontal positioning, slim chilled rolls and fibre rolls involve the drawback that the rolls "hang" down out of the plane of the calender. Further, since the forms of the deflection lines of chilled rolls and fibre rolls have been different, this "hanging" has been different in comparison between adjacent rolls. It should be stated further that rapid opening of a horizontally arranged supercalender is highly problematic. A stack of rolls divided into two parts solves the problem of incomplete loading just partially. Such an embodiment is also very expensive, because a calender in two parts requires a higher number (at least 3) of variable-crown rolls. There are also several systems of different types based on the relief of the axle-journal loads, by whose means the border line between the areas A_1 and C_1 of the calendering potential I illustrated in Fig. 1 can be made steeper, but none of the existing systems, however, eliminates the increase in the linear load towards the lower nip, produced by the masses of the rolls in the supercalender.

The present invention is directed towards the provision of a method in the calendering of a paper or of an equivalent web material as well as a calender that makes use of the method, by means of which method and calender the problems arising from the own gravity of the set of rolls of the calender in the distributions of linear loads are avoided and by means of which method and calender all the nips in the set of loads of the supercalender can be loaded adjustably in the desired way and, if necessary, substantially with the same maximum load. In view of achieving this, the method, as claimed in the aforementioned Parent Application No. 2,154,479, as the intermediate rolls, such rolls are used in which the form of the natural deflection line produced by their own gravity is substantially equal, that the nip load produced by the masses of the intermediate rolls and of the auxiliary equipment related to same is relieved

substantially completely, and that an adjustable load is applied to the calendering nips by means of a variable-crown upper or lower roll and/or by means of an external load applied to the upper or lower roll.

On the other hand, the calender that makes use of the method and claimed in the aforementioned Parent Application No. 2,154,479 is mainly characterized in that the intermediate rolls have been chosen so that the natural deflection lines produced by the own gravity of the intermediate rolls are substantially equal, that the means of suspension of the intermediate rolls are provided with relief devices, by whose means, during calendering, the nip loads produced by the masses of the intermediate rolls and of the auxiliary equipment related to them have been relieved substantially completely, and that the calendering nips have been arranged so that they can be loaded adjustably by means of a load produced by a variable-crown upper roll or lower roll and/or by means of an external load applied to the upper or lower roll.

In accordance with the present invention, there is provided a calender which comprises a frame, a variable-crown upper roll, a variable-crown lower roll, and two or more intermediate rolls fitted between the upper and lower rolls, said upper, lower and intermediate rolls being arranged on the frame of the calender as a stack of rolls and being in nip contact with one another to form calendering nips between said rolls, wherein as the intermediate rolls, hard- and soft-faced rolls are used in which the form of the natural deflection line produced by their own gravity is substantially equal and the nip loads produced by the masses of the intermediate rolls and of the auxiliary equipment related to them are relieved.

By means of the invention, compared with the prior art, remarkable advantages are obtained, of which the following should be stated in this connection. By means of the method in accordance with the invention and by means of the calender that makes use of the method, the whole of the loading or calendering potential of the roll materials can be utilized. This advantage can again be utilized either by increasing the running

speeds substantially and/or by reducing the number of nips in the calender. A reduced number of nips again results in reduced costs. By means of a higher calendering potential, an improved paper quality is obtained. An increased calendering potential can be utilized further, for example, by lowering the maximum linear loads substantially, with a resulting possibility of obtaining economies in bulk. Further, the system of relief of the roll loads in accordance with the invention also, if desired, permits an increase in the number of nips without increased linear loads, because the lowest nip is not loaded by the gravity of the set of rolls, which is the case in a normal supercalender. By means of a calender in accordance with the invention, an adjustability of the linear loads substantially wider than in conventional solutions is achieved, in which case the selection of paper grades that can be run with one and the same calender becomes considerably larger than in the prior art. Besides with invariable linear loads, the calender may also be run in the way of a traditional supercalender, i.e. with increasing linear loads, or inversely, i.e. with rising linear loads. In such a case, the regulation is carried out by adjusting the relief forces. The profiles of linear loads are kept uniform by adjusting the deflections of the lower and upper rolls. The further advantages and characteristic features of the invention come out from the following detailed description of the invention.

In the following, the invention will be described by way of example with reference 30 to the figures in the accompanying drawing.

As was stated above, Figure 1 illustrates the calendering potential that can be taken into use by means of the method and the calender in accordance with the invention.

Figure 2 is a fully schematic illustration of a uniform loading with invariable nip 5 loads in the nips in the calender, which can be achieved by means of a solution in accordance with the invention.

Figure 3 is a fully schematic illustration of a calender in accordance with the

invention, in which the form of the deflection lines of the rolls is substantially equal. Figure 4 is a schematic side view of a calender in which the method and the system in accordance with the invention are applied.

Figure 5 is an illustration corresponding to Fig. 4 of an alternative embodiment of a calender that makes use of the method and the system of the invention.

Figures 6A, 6B, 6C, 6D illustrate alternative exemplifying embodiments of the ways in which the relief force can be applied to the rolls in the calender.

With reference to Figs. 1...3 and to what was already stated above, the object of the invention is to be able to utilize the calendering potential completely, i.e. to be able to use the whole of the area $A_1 + B_1 + C_1$ of the calendering potential I illustrated in Fig. 1. In the invention, this can be achieved by eliminating the nip loads produced by the masses of the rolls in the stack of rolls 1, in which case all the nips in the calender can be loaded with the desired load, which load may be equal in all the nips. In order that the same maximum load could be used in all the nips in the calender, in the method of the invention and in the calender that makes use of the method, the natural deflections of the rolls in the stack of rolls are utilized. In such a case, in the calender, the form of an individual nip is a curve equal to the deflection line produced by the gravity of the rolls. This requires that, in the calender, the deflection lines produced by the gravity of each intermediate roll must be dimensioned so that their forms are substantially equal. Attempts have been made to illustrate this in particular in Fig. 3 in the drawing, in which the upper and lower nips of the calender are denoted with the references N'_1 and N'_9 , and the nips between the intermediate rolls in the calender with the references $2 \sim N'_8$. In such a case, the profiles imparted by each nip $N'_1 \dots N'_9$ to the paper web are retained uniform in spite of the fact that the rolls that load the nip are supported from their ends. In prior art, attempts were made to keep the calender nips as straight as possible, but a curved form of the nips is, however, not detrimental in calendering, because, for example, with a web width of 8000 mm and with a roll diameter of 1000

mm, the maximum deflection produced by the gravity of the rolls is just of an order of 0.2 mm. In a supercalender, the invariable load is applied to the calender by means of a variable-crown roll acting as the upper roll and/or by means of an external load applied to the upper roll. In order to keep the profiles even, in the stack of rolls, a variable-crown roll is also used as the lowest roll.

In the prior art, it has not been realized to make use of a solution in accordance with the invention, and it has been one of the reasons for this that, especially in supercalenders, the natural deflection lines of the intermediate rolls have differed from one another substantially. In the stack of rolls in a supercalender, chilled rolls and fibre rolls have been used alternately, whose deflections and rigidities are different. Compared with a chilled roll, the body of a fibre roll is quite slim. The development of rolls and roll coatings has introduced the possibility that, in supercalenders, polymer-coated rolls can be used as soft rolls in stead of fibre rolls. In such rolls, the thickness of the coating in relation to the diameter of the roll is quite little, in which case the roll body can be made quite rigid. Thus, especially when polymer-coated rolls are used, it is possible to construct the rolls so that the natural deflection lines of all of the intermediate rolls in a calender become substantially equal. In such a case, the form of each nip N'_1, \dots, N'_9 , in the stack of rolls in a calender is substantially equal, in the way shown in Fig. 3, whereby each nip has uniform profiles. Fig. 2 is a schematic perspective view illustrating the fact that, by means of the invention, in all nips, it is possible to obtain an equally high uniform load. On the x-axis in the system of coordinates, the nips are given, the y-axis represents the transverse direction of the machine, and the z-axis gives an example of the linear loads [kN/m].

Besides the circumstance that the natural deflection lines of the intermediate rolls in the stack of rolls should be substantially equal, in the invention it is also essential and important that the rigidities of the intermediate rolls should also be very close to one another. With such a solution, the remarkable advantage is obtained that the profiles of the calendaring nips remain good and uniform in the whole area $A_1 + B_1 + C_1$ of the

calendering potential shown in Fig. 1. As the invention is based thereon that the loads produced by the roll weights and by the auxiliary equipment are relieved completely, with equal rigidities of the intermediate rolls it is possible to correct the profiles of the nips in every nip. This correction of the profile is carried out by relieving the weights of the rolls and of the auxiliary equipment either excessively or deficiently. With the possibility of correcting the profile in each nip, the service lives of the roll coatings can be increased, because a correction need not be carried out in one nip in the stack of rolls only, which is the case in existing calenders.

Since the weights of the intermediate rolls and the related auxiliary equipment can be relieved excessively or deficiently as desired, the entire calendering potential can be utilized in the desired way, as is illustrated in section II of Fig. 1. The shaded area A₁, in the calendering potential II represents the available calendering potential. The little unshaded area B₂, in which the linear loads cannot be adjusted, arises from the construction of the calender, such as friction. In the shaded area A₂, lines have been drawn that pass across the area to different corners, by means of which lines attempts have been made to illustrate that, besides invariable linear loads of different levels, all possible linear increasing and decreasing alternatives of loading are available. In section III in Fig. 1, a situation is illustrated in which the load is applied to the stack of rolls from below and the intermediate rolls are relieved excessively so that, in the upper nips, the excessive relief is higher than in the lower nips.

If polymer-coated rolls are used as the soft rolls in the calender, in the heated chilled rolls it is possible to use higher temperatures than in prior art. In the method and calender of the method, it is also possible to use prior-art fibre rolls as the soft rolls if the bodies of the fibre rolls can be made sufficiently rigid. If polymer-coated rolls are used as the soft rolls, it is possible to form these polymer-coated rolls as cooling rolls, for example, by providing the bodies of these rolls with bores or with equivalent ducts for circulation of a cooling medium. In such a case, the service life of the coating can be increased and, moreover, for this reason, the temperatures in the heated chilled

rolls can be raised. This has a significant effect on an improved calendering result.

Fig. 4 is a schematic side view of a supercalender in which the method in accordance with the invention is applied. In Fig. 4, the supercalender is denoted generally with the reference numeral 10, and it comprises a calender frame II, in which a stack of rolls 12 consisting of a number of rolls has been mounted in the vertical plane. The stack of rolls 12 comprises an upper roll 13, a lower roll 14, and a number intermediate rolls 15...22 fitted one above the other between the upper roll and the lower roll, said rolls being arranged so that they are in nip contact with one another. The paper web W is passed over a spreader roll 135 and a take-out leading roll 136 into the upper nip N_1 and further through the other nips $N_2...N_8$ in the calender and finally out from the lower nip N_9 . At the gaps between the nips $N_1...N_9$, the paper web W is taken apart from the roll faces by means of take-out leader rolls 156,167.

The upper roll 13 in the calender is a variable-crown roll, and it is provided with an 25 upper cylinder 134 placed at each end of the roll and attached to the frame 11 of the calender, the piston of said cylinder 134 acting upon the bearing housing 131 of the upper roll. The axle of the variable-crown upper roll 13 is mounted in said bearing housing 131, and the roll is conventionally provided with inside loading means, by which the deflection of the roll mantle can be regulated in the desired way. On the frame 11 of the calender, vertical guides 132 have been formed, on which the bearing housings 131 are fitted displaceably and along which the bearing housings 131 can be displaced by means of the upper cylinders 134. In the solution in accordance with the invention, properly speaking, the upper cylinders 134 need not be used for loading the stack of rolls 12, but in such a case the upper cylinders 134 are used for closing and opening the upper nip N_1 . It is, however, also possible to use the upper cylinders 134 for loading the stack of rolls 12, either alone or together with the inside loading means in the variable-crown upper roll 13. The loading proper of the nips $N_1...N_9$ in the stack of rolls 12 can also be arranged exclusively by means of the inside loading means in

the variable-crown upper roll 13 or lower roll 14. In the embodiment as shown in Fig. 4, the upper roll 13 is provided with a resilient polymer coating.

Similarly, the lower roll 14 in the calender is a variable-crown roll, whose roll mantle is mounted revolvingly on the roll axle and which roll 14 is provided with inside loading means, by which the deflection of the roll mantle can be regulated in the desired way. The axle of the lower roll 14 is mounted in the bearing housings 141, which can be displaced in the vertical plane by means of lower cylinders 143. Thus, by means of the lower cylinders 143, the stack of rolls 12 can be opened in the conventional way. Owing to the variable-crown lower roll 14, the profiles of linear loads can be kept uniform in the nips $N_1 \dots N_9$ in the stack of rolls 12. In Fig. 4, the lower roll is provided with a resilient polymer coating 142, as was also the case in respect of the upper roll 13.

As was already described above, between the upper roll 13 and the lower roll 14, a number of intermediate rolls 15...22 are fitted, which are in nip contact with one another, and in the following, of these intermediate rolls, the uppermost two intermediate rolls 15,16 will be described in more detail. In the illustrated embodiment, the uppermost intermediate roll 15 is a hard-faced roll, whose ends are mounted revolvingly in the bearing housings 151. The bearing housings 151 are mounted on arms 152, which are linked pivotally on the calender frame 11 by means of articulated joints 153 parallel to the axis of the roll 15. The arms 152 are provided with relief devices 154, which are, in the embodiment shown, pressure-medium operated piston-cylinder devices, one of whose ends is attached to said arms 152 and the opposite end to brackets 155 mounted on the frame 11 of the calender. Said piston-cylinder devices 154 may be, e.g., hydraulic or pneumatic cylinders or equivalent.

The second-highest intermediate roll 16 is again a soft-faced roll, which is, in the exemplifying embodiment shown, provided with a resilient polymer coating 166.

Said roll 16 is mounted by its ends revolvingly in bearing housings 161, which are mounted on respective arms 162. The arms 162 are linked pivotally on the calender frame 11 by means of articulated joints 163 parallel to the axial direction of the roll 16. Further, the arms 162 are provided with relief devices, for example with pressure-medium operated piston-cylinder devices 164, one of whose ends is attached to said arms 162 and the opposite end to the brackets 165 mounted on the calender frame 11. Further, the bearing housings of the take-out leading roll 167 are attached to the bearing housings 161 of the second-highest intermediate roll 16. The support of the other intermediate rolls is not denoted in detail with reference denotations in Fig. 4, but, as can be seen from Fig. 4, the support of these rolls 17...22 is similar.

By means of the relief devices 154,164, a relief force is applied to the support constructions of the rolls 15,16, by means of which force the whole of the loads produced by the weight of the rolls and of the auxiliary equipment 167 attached to the rolls is compensated for. Thus, the weight of the rolls and of the auxiliary equipment has no increasing effect whatsoever on the nip loads. Thus, in each nip $N_1 \dots N_9$, if desired, the linear load can be made substantially equally high, in which case the profiles of the nip loads are similar to those shown in Fig. 2. This comes from the fact that an invariable load is applied to the calender by means of the variable-crown roll that is used as the upper roll 13.

In connection with the description of Fig. 4, it was stated that the intermediate rolls in the stack of rolls 12 consist of alternating hard-faced and soft-faced rolls. It is, however, fully possible that all the rolls in the stack of rolls 12 are hard-faced rolls and that the number of the intermediate rolls is substantially lower than that shown in Fig. 4. In such a case, the calender shown in Fig. 4 can be used, for example, as a machine calender. In such a case, the number of the intermediate rolls must be, as a rule, at least two. It is also completely obvious that the number of intermediate rolls may be even substantially higher than that shown in Fig. 4. Similarly to a normal

construction known from supercalenders, the hard-faced rolls 15,17,20,22 can be arranged heatable. It is also possible that only the uppermost hard rolls 15,17 are heated, the heat being transferred along with the web W to the lower nips $N_5 \dots N_9$.

Fig. 5 shows an illustration corresponding to Fig. 4 of a second supercalender that makes use of the method of the invention. In Fig. 5, the supercalender is denoted generally with the reference numeral 10a, and it comprises a calender frame 11a, on which a stack of rolls 12a consisting of a number of rolls is mounted in the vertical plane. The stack of rolls 12a comprises an upper roll 13a, a lower roll 14a, and a number of intermediate rolls 15a...22a fitted one above the other between the upper roll and the lower roll, said rolls being arranged so that they are in nip contact with one another. The paper web W is passed over a spreader roll 135a and a take-out leading roll 136a into the upper nip N_1 and further through the other nips $N_2 \dots N_8$ in the calender and finally out from the lower nip N_9 . At the gaps between the nips $N_1 \dots N_9$, the paper web W is taken apart from the roll faces by means of the takeout leading rolls 156a,167a.

In a way corresponding to Fig. 4, also in this embodiment, the upper roll 13a in the calender is a variable-crown roll, whose bearing housing 131a is, differing from the embodiment shown in Fig. 4, attached directly and rigidly to the frame 11a of the calender. The axle of the variable-crown upper roll 13a is mounted in said bearing housing 131a, and the roll is conventionally provided with inside loading means, by which the deflection of the roll mantle can be regulated in the desired way.

In a similar way, the lower roll 14a in the calender is a variable-crown roll, whose roll mantle is mounted revolvingly on the roll axle and which roll 14a is provided with inside loading means, by which the deflection of the roll mantle can be regulated in the desired way. The axle of the lower roll 14a is mounted in bearing housings 141a, which are, differing from the embodiment shown in Fig. 4, mounted on loading arms 144a, which are linked by means of articulated joints 145a to the

calender frame 11a. Between the calender frame 11a and the loading arms 144a, lower cylinders 143a are mounted, by whose means the lower roll 14a can be displaced in the vertical direction. Thus, in the embodiment shown in Fig. 5, the stack of rolls 12a can be loaded by means of the lower cylinders 143a and, moreover, by means of said lower cylinders 143a, the stack of rolls 12a can be opened. Owing to the variable-crown lower roll 14a, the profiles of linear loads can be kept uniform in the nips $N_1 \dots N_9$ in the stack of rolls 12a. In the embodiment of Fig. 5, the lower roll 14a is also provided with a resilient polymer coating 142a.

The intermediate rolls 15a...22a in the stack of rolls 12a are substantially similar to those described in connection with Fig. 4. Thus, in the embodiment of Fig. 5, the topmost intermediate roll 15a is a hard-faced roll, which is mounted by its ends revolvingly in the bearing housings 151a. The bearing housings 151a are mounted on arms 152a, which are linked pivotally on the calender frame 11a by means of articulated joints 153a parallel to the axial direction of the roll 15a. The arms 152a are provided with relief devices 154a, which are, also in the embodiment of Fig. 5, pressure-medium operated piston-cylinder devices, which are, by one end, attached to said arms 152a and, by the opposite end, to the calender frame 11a. The piston-cylinder devices 154a may be hydraulic or pneumatic cylinders or equivalent.

In the embodiment of Fig. 5, the second-highest intermediate roll 16a is a soft-faced roll, which is provided with a resilient polymer coating 166a. Said roll 16a is mounted by its ends revolvingly in the bearing housings 161a, which are mounted on respective arms 162a. The arms 162a are linked pivotally on the calender frame 11a by means of articulated joints 163a parallel to the axial direction of the roll 16a. The arms 162a are provided with relief devices, for example pressure-medium operated piston-cylinder devices 164a, which are, by one end, attached to said arms 162a and, by the opposite end, to the calender frame 11a. Further, the bearing housings of the take-out leading roll 167a are attached to the bearing housings 161a of the second-highest intermediate roll 16a. Even if the support of the other intermediate rolls is not indicated in more detail in Fig. 5, it can, however, be seen clearly from the figure that

the support of these rolls 17a...22a is similar.

Above, it was described that the intermediate rolls 15a...22a in the stack of rolls 12a consist of alternating hard-faced and soft-faced rolls, but it is, however, also possible to form the stack of rolls 12a exclusively of hard rolls. It is also possible to provide the hard rolls with heating, either so that all the hard rolls 15a,17a,20a,22a in the stack of rolls 12a are heatable rolls, or the topmost hard rolls 15a,17a in the stack of rolls 12a alone may be arranged heatable. If necessary, the polymer-faced soft rolls 16a,18a,19a,21a can be provided with cooling. By means of a calender as shown in Fig. 5, it is possible, if desired, to provide such a regulation of the linear loads as is shown in section III in Fig. 1.

The embodiments shown in Figs. 4 and 5 are some examples of the ways in which the relief force can be applied to the intermediate rolls 15...22,15a...22a in the stack of rolls 12, 12a by means of the relief devices 154,164,154a,164a. Many other solutions for application of the relief force are also possible, and Figs. 6A, 6B, 6C, and 6D illustrate some alternative solutions for the introduction of the relief force. Fig. 6A shows an exemplifying embodiment in which the relief force, which is denoted with an arrow and with a reference F in Fig. 6A, is applied directly to the bearing housing 3 of the roll 2.

In the exemplifying embodiment of Fig. 6B, the bearing housing 3 of the roll 2 is mounted on a rocker arm 4, which is mounted on the frame 11 of the calender. In the exemplifying embodiment of Fig. 6B, the relief force F is applied to the rocker arm 4 at the opposite side of the articulation point of the rocker arm, opposite in relation to the roll 2, in which case the relief force F is, of course, of a direction opposite to that shown in Fig. 6A.

The exemplifying embodiment shown in Fig. 6C corresponds to the solution shown in Figs. 4 and 5 so that the relief force F is applied to the rocker arm 4 in the area

between the bearing housing 3 of the roll 2 and the journalling point of the rocker arm 4 on the calender frame 11.

On the other hand, Fig. 6D shows an exemplifying embodiment in which the relief force F is applied to the roll 2 quite far in the same way as is shown in Fig. 6C. In the solution of Fig. 6D, the support of the roll 2 is, however, arranged by means of a linkage, which comprises a parallel linkage 4,5, owing to which, when the roll 2 is raised and lowered, the position of the bearing housing 3 of the roll 2 is not changed during the movement. Other sorts of modes of support and modes of relief are also possible in the method in accordance with the invention and in the calender that makes use of the method. It is, however, the most important thing that the loads arising from the weight of the whole roll and of the related auxiliary equipment are compensated for by means of relief forces F.

Above, the invention has been described by way of example with reference to the figures in the accompanying drawing. The invention is, however, not confined to the exemplifying embodiments shown in the figures alone, but different embodiments of the invention may vary within the scope of the inventive idea defined in the accompanying patent claims.

The embodiments of the invention in which an exclusive property or privilege is claimed are defined as follows:

1. Calender which comprises a frame, a variable-crown upper roll, a variable-crown lower roll and at least two or more intermediate rolls fitted between the upper and lower rolls, said upper, lower and intermediate rolls being arranged on the frame of the calender as a stack of rolls and being in nip contact with one another to form calendering nips between said rolls, wherein as the intermediate rolls, hard- and soft-faced rolls are used in which the form of the natural deflection line produced by their own gravity is substantially equal and the nip loads produced by the masses of the intermediate rolls and of the auxiliary equipment related to them are relieved.
2. Calender according to claim 1, wherein auxiliary equipment is attached to the intermediate rolls, and wherein the weights of the intermediate rolls and the related auxiliary equipment are relievable.
3. Calender according to claim 2, wherein there is means of suspension of the intermediate rolls provided with relief devices, by whose means, during calendering, the nip loads produced by the masses of the intermediate rolls and the auxiliary equipment related to them are relievable, wherein the calendering nips are arranged so that they are adjustably loadable by means of a load produced by the variable-crown upper roll and an external load applied to the upper roll or by means of a load produced by the variable-crown lower roll and an external load applied to the lower roll.
4. Calender according to claim 3, wherein the relief devices are individually adjustable.
5. Calender according to any one of claims 1 to 3, wherein the upper and lower variable-crown rolls are covered with a resilient polymer coating.
6. Calender according to any one of claims 1 to 5, wherein the intermediate rolls in the stack of rolls are both hard rolls and soft-faced rolls.

7. Calender according to any one of claims 1 to 6, wherein the rigidities of all the intermediate rolls are equal or almost equal.
8. Calender according to any one of claims 1 to 7, wherein the relief devices are arranged between the calender frame and the bearing housing of each intermediate roll.
9. Calender according to any one of claims 1 to 7, wherein the relief devices are arranged between the calender frame and the means of suspension of each intermediate rolls.
10. Calender according to any one of the claims 1 to 9, wherein the relief devices are pressure-medium operated piston-cylinder devices.
11. Calender according to any one of claims 6 to 10, wherein the soft-faced rolls in the calender are provided with a resilient polymer coating.
12. Calender according to any one of claims 6 to 10, wherein the soft-faced rolls in the calender are fibre rolls that have a rigid roll body.
13. Calender according to any one of claims 6 to 12, wherein at least one of the hard-faced rolls is a heatable roll.
14. Calender according to any one of claims 6 to 13, wherein the soft-faced rolls are cooling rolls.
15. Calender according to any one of claims 6 to 13, wherein at least one of the intermediate rolls is a cooled roll, which is provided with a resilient polymer coating and with ducts formed in the body of said roll for circulation of a cooling medium.

1 / 5

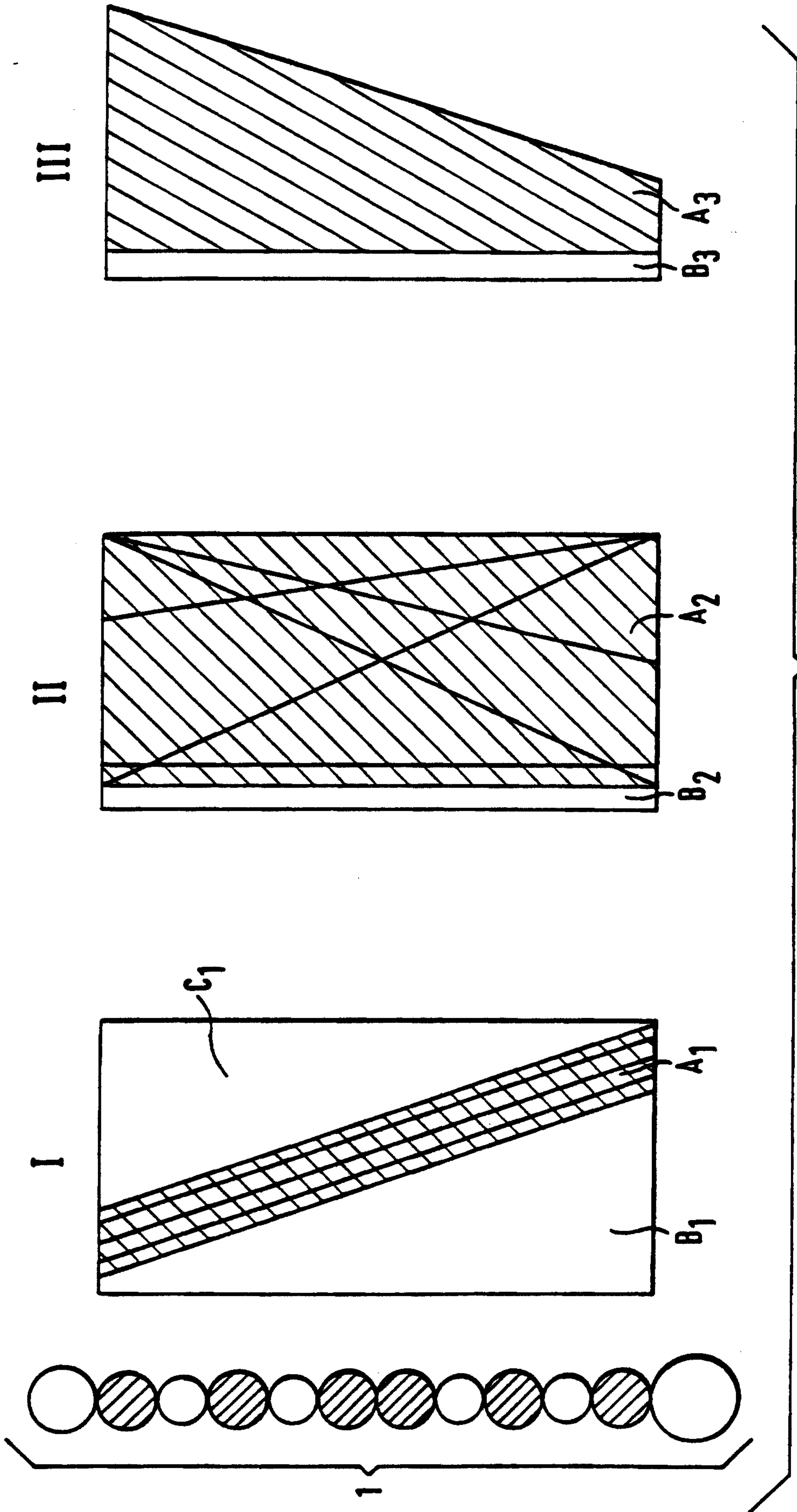

Fig.1

2 / 5

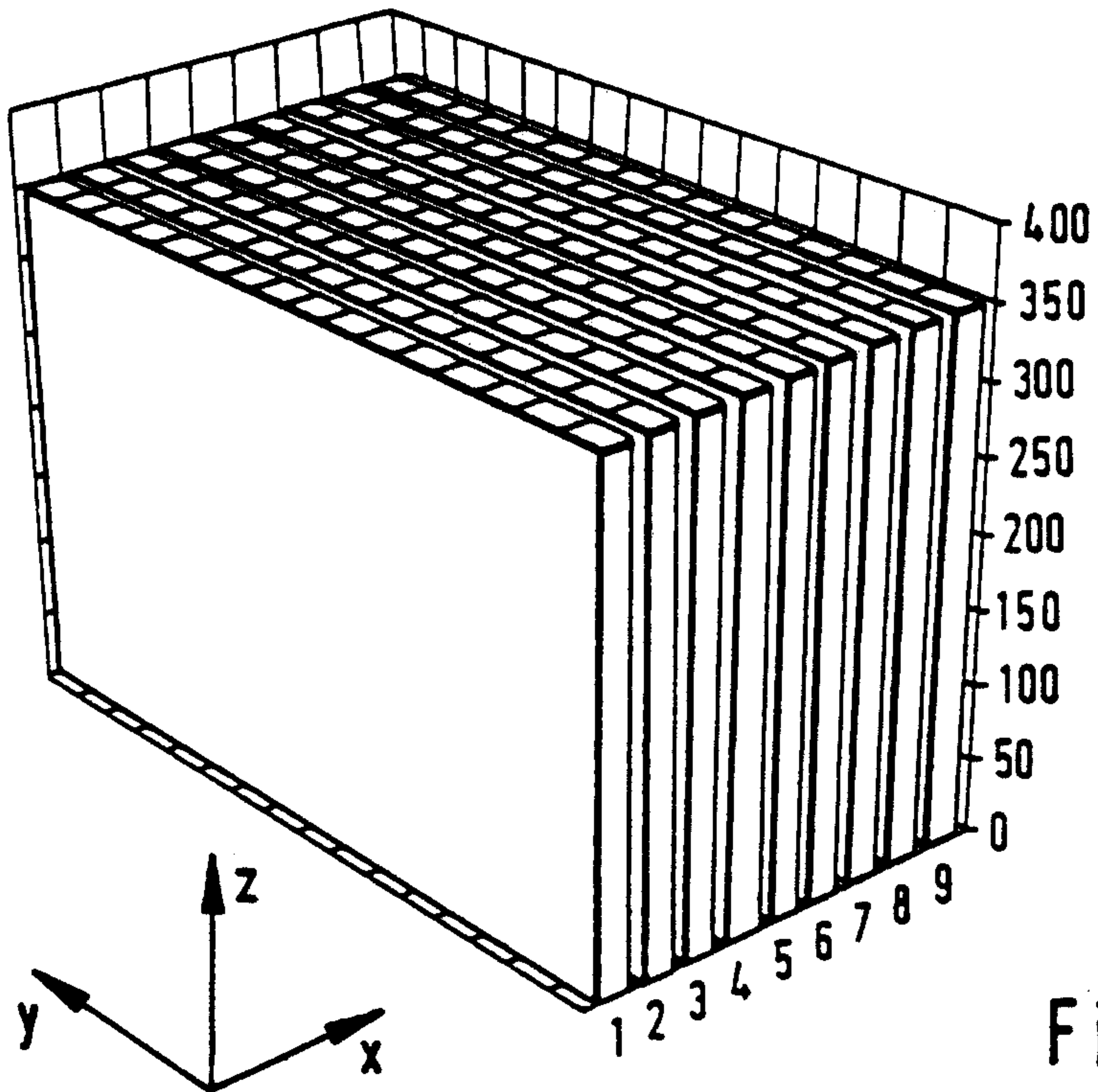

Fig. 2

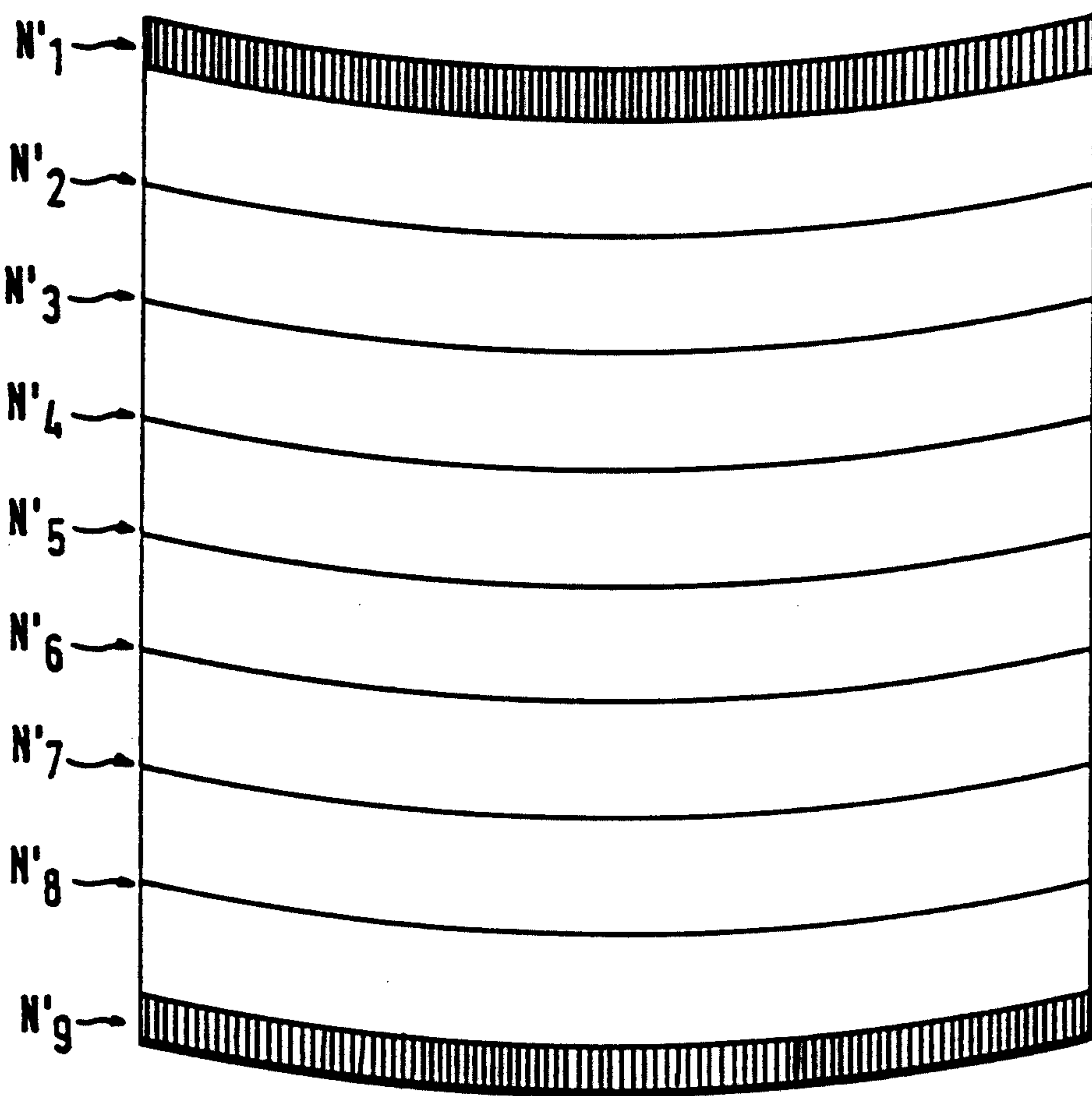

Fig. 3

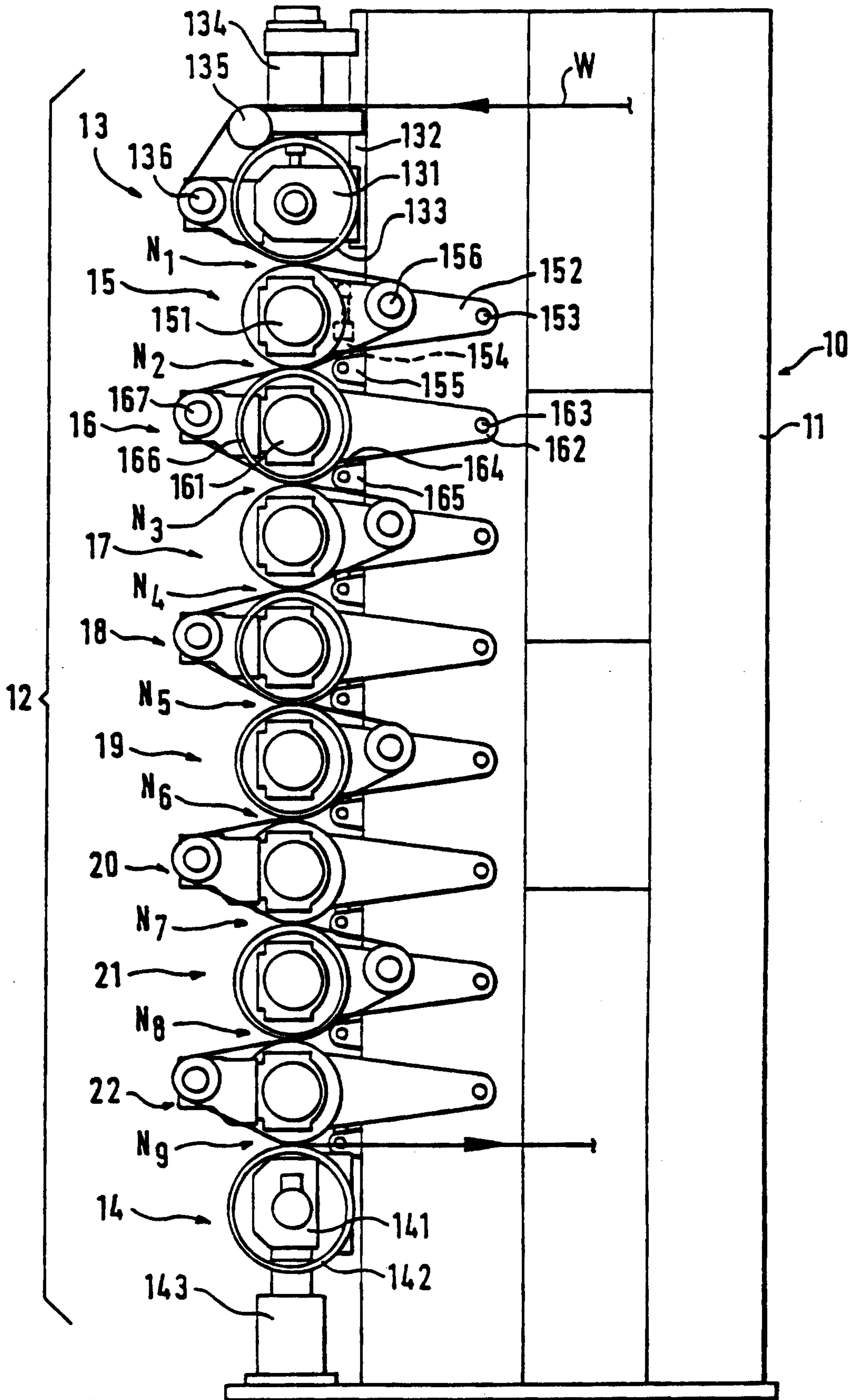

Fig. 4

4 / 5

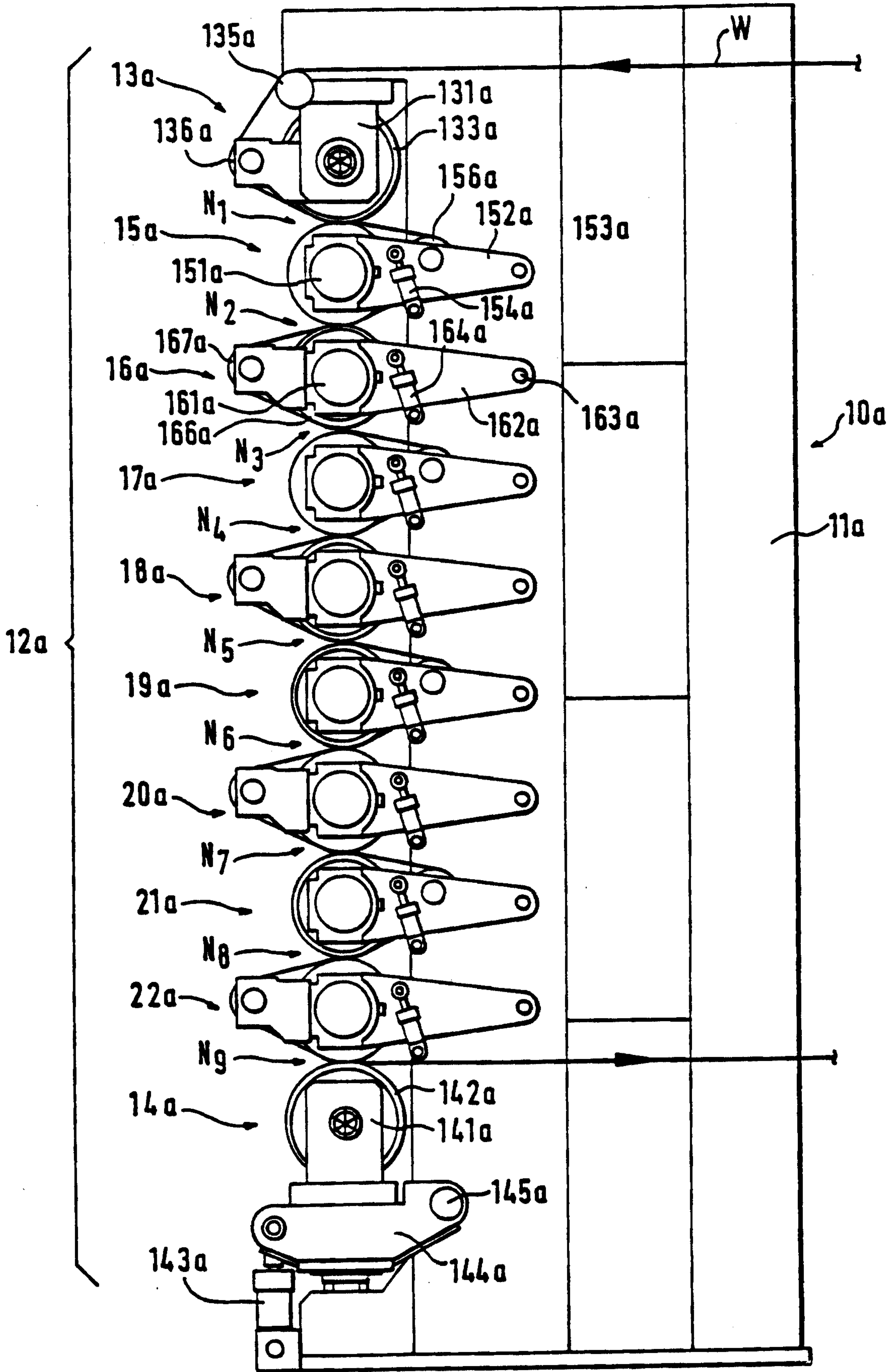

Fig. 5

5 / 5

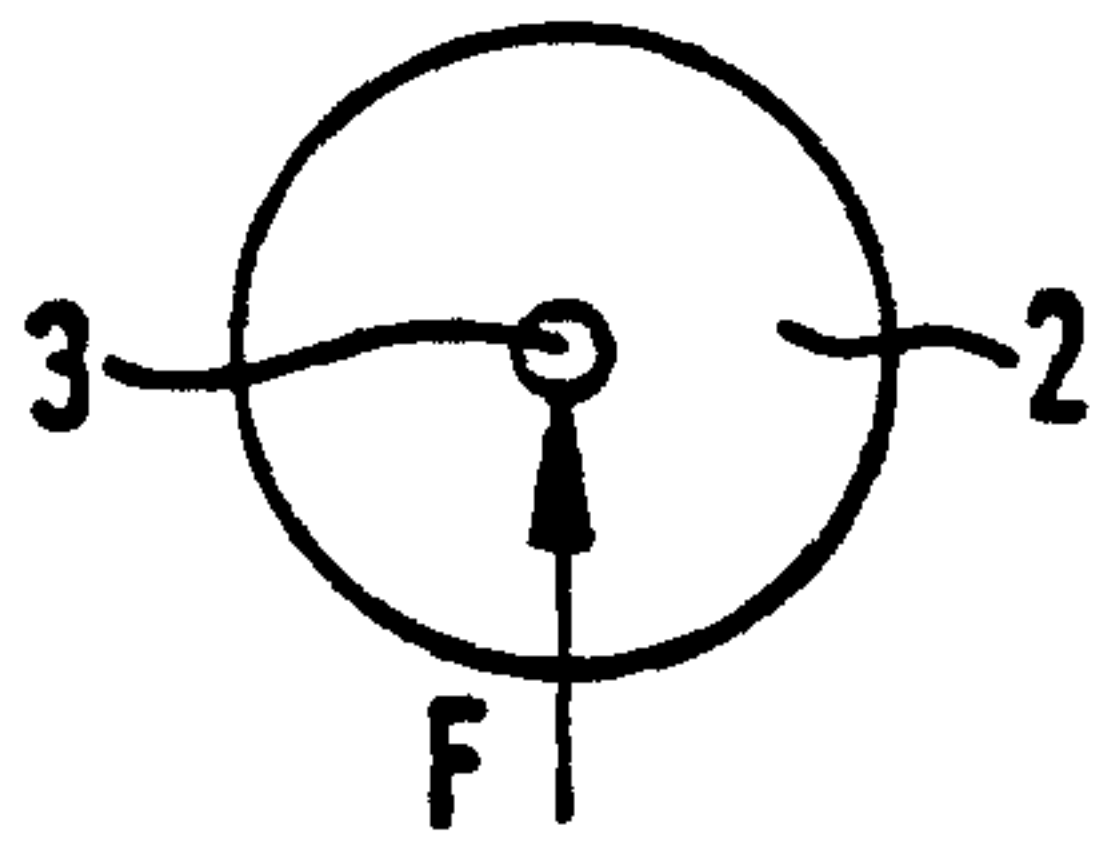

Fig. 6A

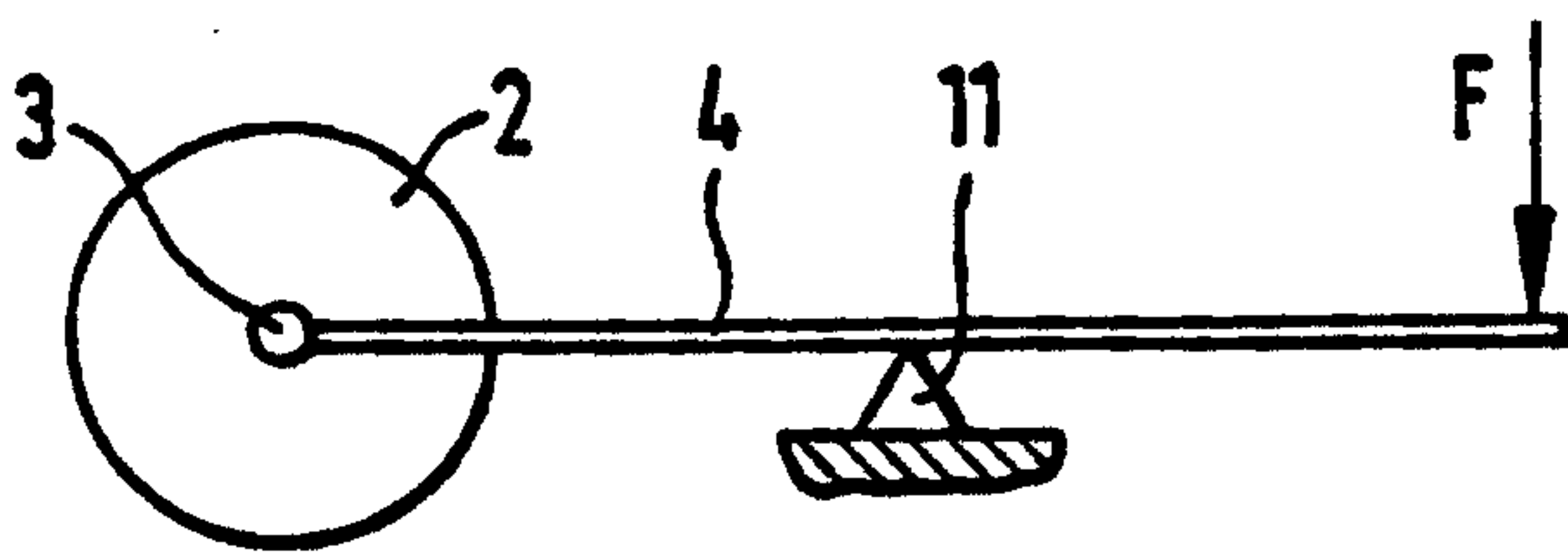

Fig. 6B

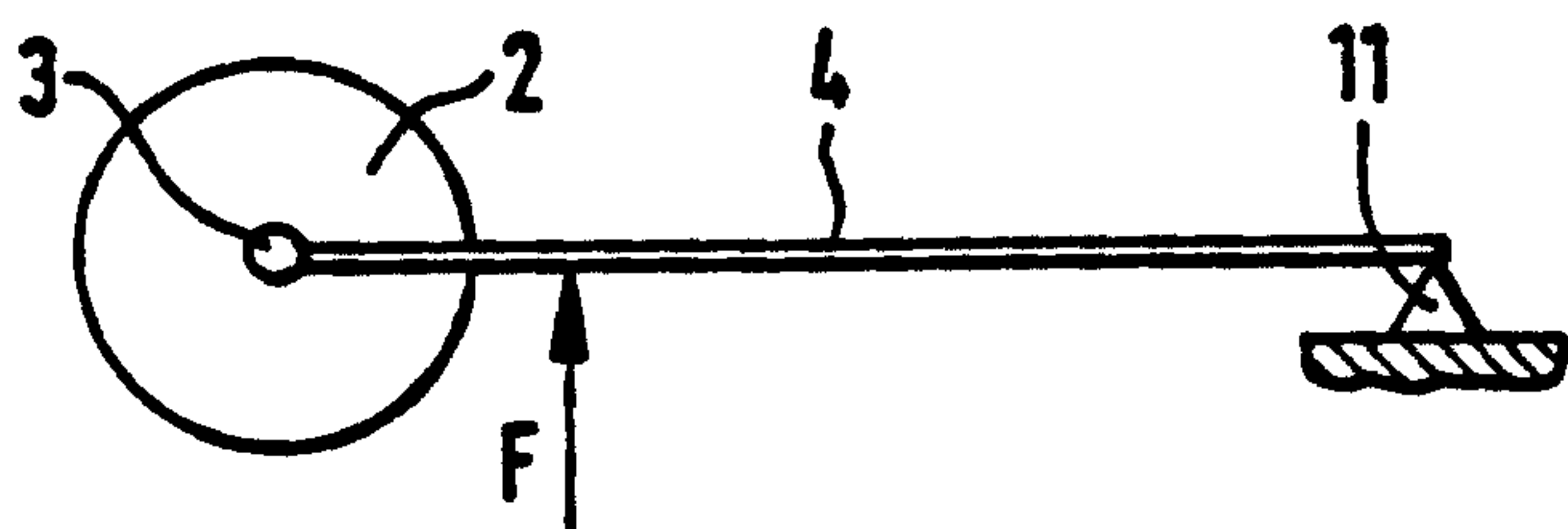

Fig. 6C

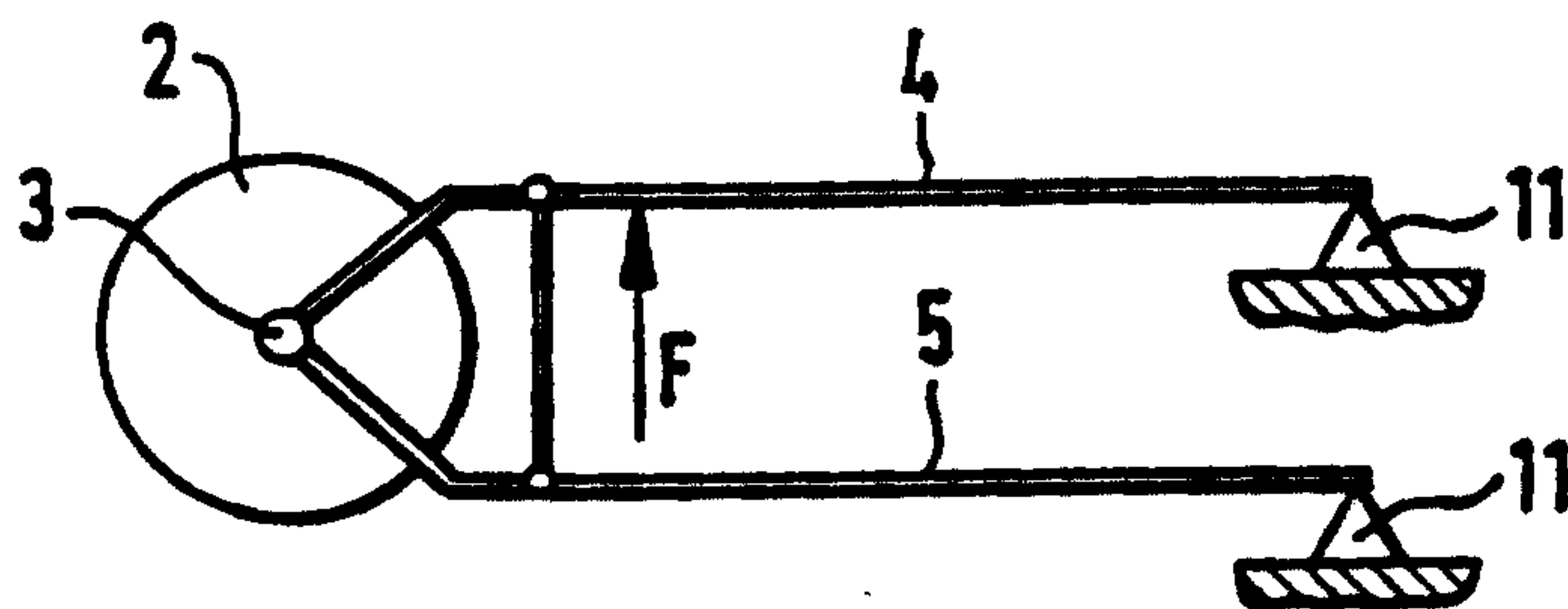

Fig. 6D

