

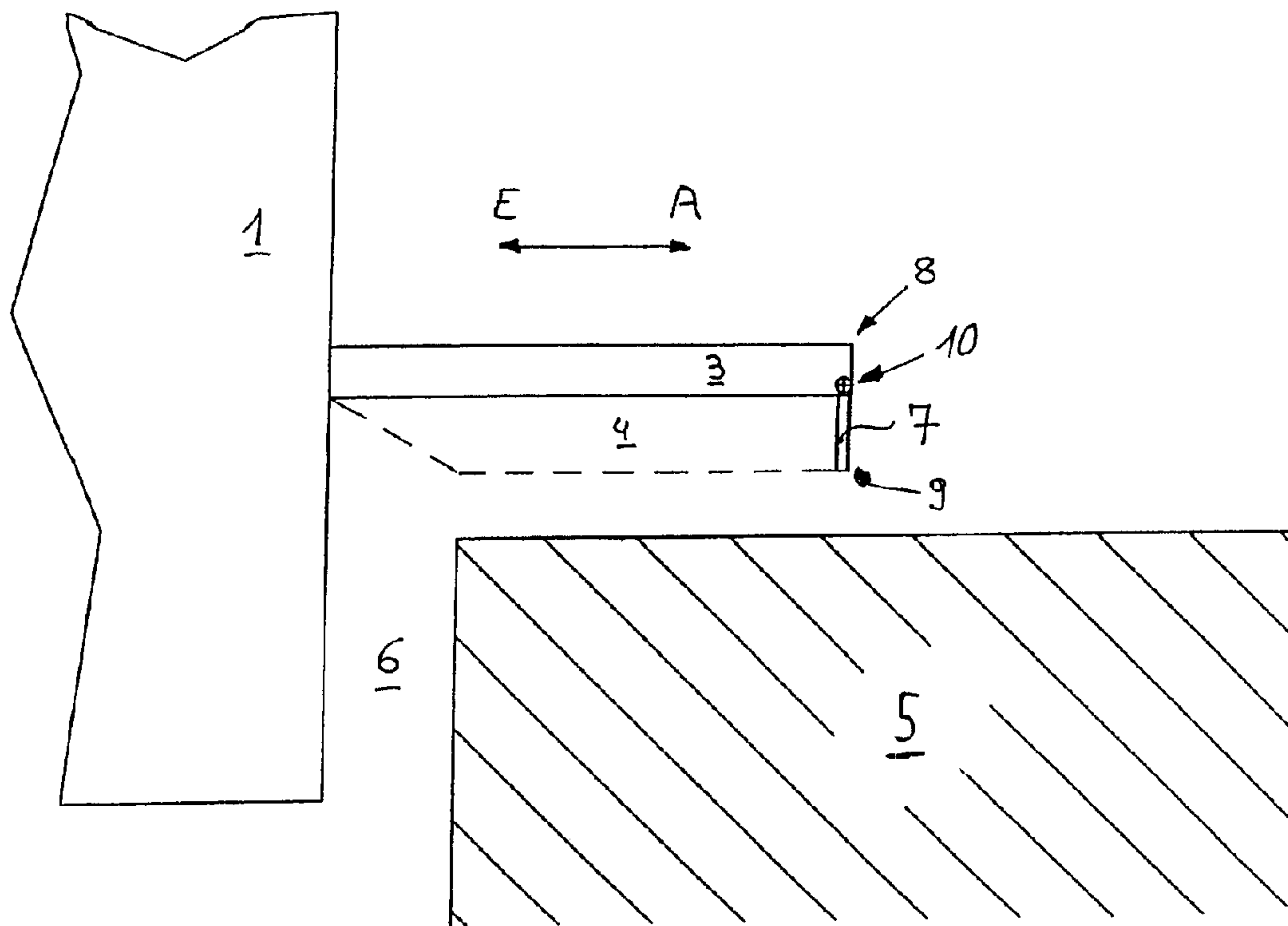

(86) Date de dépôt PCT/PCT Filing Date: 2004/02/20  
 (87) Date publication PCT/PCT Publication Date: 2004/10/07  
 (45) Date de délivrance/Issue Date: 2011/10/04  
 (85) Entrée phase nationale/National Entry: 2005/09/13  
 (86) N° demande PCT/PCT Application No.: EP 2004/001667  
 (87) N° publication PCT/PCT Publication No.: 2004/085222  
 (30) Priorité/Priority: 2003/03/25 (AT A 472/2003)

(51) Cl.Int./Int.Cl. *B61D 23/02* (2006.01),  
*B60R 3/02* (2006.01)  
 (72) Inventeur/Inventor:  
TAZREITER, ANDREAS, AT  
 (73) Propriétaire/Owner:  
KNORR-BREMSE GES. M.B.H., AT  
 (74) Agent: FETHERSTONHAUGH & CO.

(54) Titre : MARCHE COULISSANTE  
 (54) Title: RETRACTABLE STEP



(57) Abrégé/Abstract:

The invention relates to an entry aid for assisting the entering and exiting of vehicles, particularly rail vehicles. In order to bridge the gap between the vehicle and the platform or the like, a surface upon which passengers can walk, i.e. a retractable step, is extended from the vehicle in an essentially linear direction. The invention is characterized in that a strip is displaceably connected to the retractable step, extends essentially over the entire length of the retractable step and, when in an active state, is located, in essence, under the leading edge of the retractable step. The invention is additionally characterized in that at least one sensor is provided that detects either the position of the strip relative to the retractable step or the force is transferred from the strip to the retractable step.

## Abstract

The invention relates to an entry aid for assisting the entering and exiting of vehicles, particularly rail vehicles. In order to bridge the gap between the vehicle and the platform or the like, a surface upon which passengers can walk, i.e. a retractable step, is extended from the vehicle in an essentially linear direction. The invention is characterized in that a strip is displaceably connected to the retractable step, extends essentially over the entire length of the retractable step and, when in an active state, is located, in essence, under the leading edge of the retractable step. The invention is additionally characterized in that at least one sensor is provided that detects either the position of the strip relative to the retractable step or the force is transferred from the strip to the retractable step.

## Retractable step

The invention relates to what is referred to as a retractable step. A retractable step is understood as meaning an entry aid for assisting the entering and exiting of vehicles, particularly rail vehicles, with a surface which can be walked upon being extended from the vehicle essentially in a linear direction in order to bridge the gap between the vehicle and the platform or the like.

Depending in each case on the positioning between the vehicle box body and the platform, the retractable step, generally toward the end of its extension movement, comes into the region of the platform and there is the risk in this case of it moving laterally into the essentially vertically extending platform wall. This problem is overcome by means of sensors in the region of the leading edge of the retractable step.

Another problem is that, in the case of an extended retractable step, a change in height of the retractable step may occur during the time the vehicle spends in the station. This may take place within a short period by the suspension yielding, by the vehicle load changing as passengers get in and out, by the wind load stressing changing, and by more of the same sort of reasons. The greatest possible change in height is defined here by various parameters of the vehicle (type of suspension, position of the stops, length of the lever arms of the retractable step relative to the pivot axis, etc.) and is called maximum change in height below. The actual change in the height position within the context of this maximum change in height may result in luggage or passengers becoming trapped, or the retractable step being damaged if the retractable

step is correspondingly lowered. Since the objects at risk generally do not extend over the entire width of the retractable step and it cannot be predicted in which region of the retractable step they are located, detection has hitherto been impossible and the risk of body parts or objects becoming trapped or of the retractable step becoming damaged has had to be accepted.

10 The invention aims to change this and to specify a device with which it is possible to carry out a detection of this type in a satisfactory and cost-effective manner.

15 According to the invention, this is achieved in that a strip is connected movably to the retractable step, said strip extending essentially over the entire length of the retractable step and, in the activated state, being located essentially under the front edge of the retractable step, and by at least one sensor being provided which detects the position of the strip and/or the force transmitted by the strip to the retractable step.

20

25 In accordance with an aspect of the present invention, there is provided a retractable step for entering and exiting of a vehicle, the retractable step having a surface which can be walked upon and being extendible from the vehicle essentially in a linear direction in order to bridge a gap between the vehicle and a platform, the retractable step comprising a device with at least one sensor, to prevent collisions with objects during extension, wherein the device comprises a strip that is connected movably to the retractable step and extends essentially over the entire length (L) of the

30

35

2a

retractable step and, in an activated state, is located essentially under a leading edge of the retractable step, and comprises at least one sensor which detects at least one of a position of the strip  
5 relative to the retractable step or a force transferred from the strip to the retractable step.

In accordance with another aspect of the present invention, there is provided a retractable step for entering and exiting rail vehicles, the retractable  
10 step having a surface which can be walked upon and being configured to be extended in an essentially linear direction to bridge a gap between the rail vehicle and a platform. The retractable step comprises: a leading edge; a strip being movably  
15 connected to the retractable step and extending over an entire length L of the retractable step; the strip having at least one sensor and arranged to prevent a collision with objects during an extension operation of the retractable step. When the retractable step is in  
20 an extended position, the strip is at least partially located under the leading edge and the at least one sensor detects one of the following: (1) a position of the strip relative to the retractable step and (2) a force transferred from the strip to the retractable  
25 step; and wherein the strip is a rotatable flap.

In accordance with yet another aspect of the present invention, there is provided a retractable step for entering and exiting rail vehicles. The retractable step has a surface which can be walked upon and being  
30 configured to be extended in an essentially linear direction to bridge a gap between the rail vehicle and

2b

a platform. The retractable step comprises: a leading edge; a strip being movably connected to the retractable step and extending over an entire length L of the retractable step; the strip having at least one  
5 sensor and arranged to prevent a collision with objects during an extension operation of the retractable step. When the retractable step is in an extended position, the strip is at least partially located under the leading edge and the at least one sensor detects one of  
10 the following: (1) a position of the strip relative to the retractable step and (2) a force transferred from the strip to the retractable step; and wherein the strip is a rotatable bracket.

As a result, every impermissible approach toward the  
15 upper side of the platform can be detected as can the imminent risk of an object or body part becoming trapped. The positioning of the strip makes it possible, during the extension of the retractable step, also to detect the space (detection space) in which  
20 during the lowering operation, the retractable step could move, for example for one of the abovementioned reasons, and thus makes it possible to safeguard it. The activated state is taken up by the strip at least during the extension of the retractable step.

- 3 -

The movable connection between strip and retractable step makes it possible to bring the strip into the desired position, if appropriate automatically, during  
5 the extension of the retractable step. The monitoring of this position remains activated during the extension of the retractable step into its end position.

If a change in the position of the strip is detected,  
10 the extension movement is stopped and the retractable step is moved back by a predetermined length by which a safe distance from the object is ensured. In addition, for example, an acoustic and/or optical alarm signal may be emitted. Of course, a different reaction is  
15 possible if this is desired by the operator.

The strip itself may either execute an extension movement which is oblique with respect to the direction of extension of the retractable step but is essentially  
20 linear; it may also execute a rotational movement and be swung out, as it were.

Depending in each case on the design and movement of the strip, a very wide variety of sensors, which can be  
25 designed as switches or strain gauges or are based on an electrodynamic or piezoelectric effect, are suitable as the actual sensor. The sensors may be arranged either directly in the strip and measure the force between underlying surface and strip, or they are  
30 accommodated in the region of the bearings of the strip and measure the forces between strip and retractable step, which forces originate from the first-mentioned forces.

35 The transition of the strip from the passive position

- 4 -

into the active position can take place by means of the dead weight of the strip, a slotted-guide mechanism and possibly a spring. Of course, it is also possible to provide a motor drive.

5

In order to reach the objective of the invention and in particular if the retractable step is to be retracted if a trapping risk is established, it is favorable that, during this retraction movement, the strip releases any objects already trapped as rapidly as possible without further loading and does not trap and keep hold of them.

The invention is explained in more detail below with reference to the drawing, in which  
fig. 1 shows a front view of an entry aid designed according to the invention,  
fig. 2 shows a purely diagrammatic section in the direction of the arrow II of fig. 1,  
fig. 3 shows a variant of a retractable step similar to that of fig. 2, on an enlarged scale,  
fig. 4 shows a view similar to fig. 3 of another variant of the invention, and  
fig. 5 shows the variant of the invention according to fig. 4 in a different position between the vehicle and the platform.

Fig. 1 shows a vehicle 1 with a two-wing door 2 and a retractable step 3. The "detection space" 4, i.e. that space which is to be monitored by the device according to the invention for risk of collision or trapping during the extension of the retractable step, is illustrated below the retractable step 3 by dashed lines.

35

- 5 -

The positioning and significance of this detection space 4 are apparent from putting figs 1 and 2 together: fig. 2 shows a platform 5 as it is intended normally to extend with its surface and its side wall in relation to the vehicle 1. Between the platform 5 and the vehicle 1 there is unavoidably a gap 6, precisely the gap which in many cases, if platforms in curved track sections in the case of rail vehicles are considered, may also be significantly wider than in the exemplary embodiment shown and for the safe overcoming or overclimbing of which the retractable step 3 is provided.

Fig. 3 shows the situation in the region of the platform 5 on an enlarged scale, but likewise entirely schematically. In the exemplary embodiment shown, the strip 7 provided according to the invention comprises a rotatable flap which extends over the entire length L (fig. 1) of the retractable step 3 and is located essentially precisely below the leading edge 8 of the retractable step 3, when said flap is extended in its activated position, as illustrated in fig. 3.

The dashed line below the retractable step 3 again indicates the detection space 4, i.e. the space over which the lower edge 9 of the strip 7 brushes during its extension in the direction A of the double arrow E-A. If, during the extension operation, the strip 9 impacts at any point along the length L against an object, this is established by a sensor, which is arranged, in the exemplary embodiment, in the bearing 10 between the strip 7 and the retractable step 3, and the measures provided for this purpose by the operator are taken. After reaching the end position of the retractable step, the strip has to fold away and

- 6 -

release the detection space.

Fig. 4 shows, likewise purely diagrammatically, another embodiment of a strip 7'; in this example, the strip is lowered downward about a joint 10' and a sliding movement would be possible in a similar manner. The movement of the strip 7 or 7' between the active position illustrated and the position in which it is placed against the retractable step or pushed into recesses in the contour of the retractable step 3 is brought about by the dead weight and/or by assistance by means of spring force; of course, as mentioned above, an active movement by means of a servomotor or the like is also possible.

15

Fig. 5 shows the situation which arises in the case of a device according to the invention according to fig. 4 if even during the extension of the retractable step 3, the height position of the vehicle 1 relative to the platform upper edge 11 is too low, with the result that the strip 7' impacts with its front edge 9' against the vertical front 12 of the platform 5 below the platform upper edge 11. This is also established by the position sensor in the joint 10' and results in the specified reaction, as mentioned above. The same happens if the strip 7' impacts against a different obstacle. Instead of the position sensor in the joint 10', a force sensor may be arranged directly on the front edge 9' of the strip 7'.

20  
25  
30

The invention is not restricted to the exemplary embodiments outlined and described. It is possible to design the front edges 9, 9' themselves as sensors, whether by these edges carrying profiles which are designed as electric switching strips or which are

35

- 7 -

filled with gas, in which case the rising gas pressure when running onto an object is measured and established, or whether the strips 7, 7' for their part comprise two parts which are movable with respect to each other and the movement of these parts with respect to each other is used as a measure of the striking against an obstacle.

It is essential that a strip 7, 7' is arranged in the region below the leading edge 8 of the retractable step 3 and over the entire length 11 of the retractable step, and that the load acting on this strip in its entirety and/or the position of the strip is established by means of a sensor, and that, if a specified value is exceeded, the movement is stopped and, if appropriate, an alarm is triggered.

## Patent Claims

1. A retractable step for entering and exiting of a vehicle, the retractable step having a surface which can be walked upon and being extendible from the vehicle  
5 essentially in a linear direction in order to bridge a gap between the vehicle and a platform, the retractable step comprising a device with at least one sensor, to prevent collisions with objects during extension, wherein the device comprises a strip that is connected movably to  
10 the retractable step and extends essentially over the entire length (L) of the retractable step and, in an activated state, is located essentially under a leading edge of the retractable step, and comprises at least one sensor which detects at least one of a position of the  
15 strip relative to the retractable step or a force transferred from the strip to the retractable step.
2. The retractable step as claimed in claim 1, characterized in that the strip is a rotatable flap.
3. The retractable step as claimed in claim 1,  
20 characterized in that the strip is a rotatable bracket.
4. The retractable step as claimed in claim 1, characterized in that the strip is a bracket which can be displaced in a guide.
5. The retractable step as claimed in claim 2 or 3,  
25 characterized in that the sensor measures an angle between the strip and the retractable step.
6. The retractable step as claimed in one of claims 1 to 4, characterized in that the sensor is fitted to a front edge of the strip.
- 30 7. A retractable step for entering and exiting rail

vehicles, the retractable step having a surface which can be walked upon and being configured to be extended in an essentially linear direction to bridge a gap between the rail vehicle and a platform, the retractable step

5 comprising:

a leading edge;

a strip being movably connected to the retractable step and extending over an entire length L of the retractable step;

10 the strip having at least one sensor and arranged to prevent a collision with objects during an extension operation of the retractable step;

15 wherein, when the retractable step is in an extended position, the strip is at least partially located under the leading edge and the at least one sensor detects one of the following: (1) a position of the strip relative to the retractable step and (2) a force transferred from the strip to the retractable step; and

wherein the strip is a rotatable flap.

20 8. The retractable step of claim 7, wherein the strip is a bracket displaceable in a guide.

9. The retractable step of claim 7, wherein the at least one sensor is fitted to a front edge of the strip.

10. A retractable step for entering and exiting rail  
25 vehicles, the retractable step having a surface which can be walked upon and being configured to be extended in an essentially linear direction to bridge a gap between the rail vehicle and a platform, the retractable step comprising:

a leading edge;

a strip being movably connected to the retractable step and extending over an entire length L of the retractable step;

5 the strip having at least one sensor and arranged to prevent a collision with objects during an extension operation of the retractable step;

10 wherein, when the retractable step is in an extended position, the strip is at least partially located under the leading edge and the at least one sensor detects one of the following: (1) a position of the strip relative to the retractable step and (2) a force transferred from the strip to the retractable step; and

wherein the strip is a rotatable bracket.

15 11. A retractable step for entering and exiting rail vehicles, the retractable step having a surface which can be walked upon and being configured to be extended in an essentially linear direction to bridge a gap between the rail vehicle and a platform, the retractable step  
20 comprising:

a leading edge;

a strip being movably connected to the retractable step and extending over an entire length L of the retractable step;

25 the strip having at least one sensor and arranged to prevent a collision with objects during an extension operation of the retractable step;

wherein, when the retractable step is in an extended position, the strip is at least partially located under

the leading edge and the at least one sensor detects one of the following: (1) a position of the strip relative to the retractable step and (2) a force transferred from the strip to the retractable step; and

5            wherein the at least one sensor measures an angle between the strip and the retractable step.

