



(86) Date de dépôt PCT/PCT Filing Date: 2014/10/30
 (87) Date publication PCT/PCT Publication Date: 2016/05/06
 (85) Entrée phase nationale/National Entry: 2017/03/21
 (86) N° demande PCT/PCT Application No.: JP 2014/078954
 (87) N° publication PCT/PCT Publication No.: 2016/067419

(51) Cl.Int./Int.Cl. *G01S 13/90* (2006.01),
G01S 13/28 (2006.01)
 (71) Demandeur/Applicant:
MITSUBISHI ELECTRIC CORPORATION, JP
 (72) Inventeurs/Inventors:
TSUCHIDA, MASAYOSHI, JP;
SUWA, KEI, JP;
HARA, TERUYUKI, JP
 (74) Agent: KIRBY EADES GALE BAKER

(54) Titre : APPAREILLAGE RADAR A OUVERTURE SYNTHETIQUE
 (54) Title: SYNTHETIC APERTURE RADAR APPARATUS

FIG.1

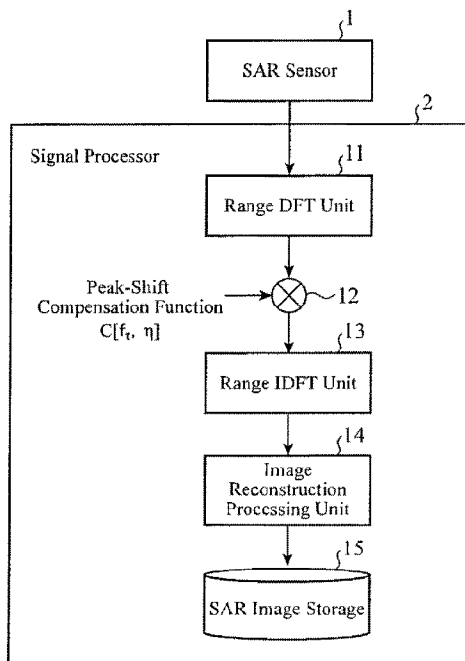

(57) **Abrégé/Abstract:**

A signal processing device (2) is configured so as to compensate for the peak shifting of the distance between an SAR sensor (1) and a target generated in a reception signal after range compression by an image reproduction processing unit (14) that occurs in association with the movement of the SAR sensor (1) during the period from the emission of a pulse signal by the SAR sensor (1) to the reception of the reflected pulse signal by the SAR sensor (1). As a result, even if the SAR sensor (1) moves, an SAR image without azimuth ambiguity can be reproduced.

ABSTRACT

A signal processor 2 is configured so as to compensate for a peak shift of the distance between an SAR sensor 1 and
5 a target, the peak shift occurring in the received signal subjected to range compression performed by an image reconstruction processing unit 14 due to a movement of the SAR sensor 1 during a time period until a reflected wave of a pulse signal is received by the SAR sensor 1 after the pulse signal
10 is emitted from the SAR sensor 1. As a result, even when the SAR sensor 1 moves, an SAR image in which no azimuth ambiguity occurs can be reconstructed.

DESCRIPTION

TITLE OF INVENTION

SYNTHETIC APERTURE RADAR APPARATUS

TECHNICAL FIELD

5 [0001]

The present invention relates to a synthetic aperture radar apparatus that reconstructs an SAR image from received signals of a synthetic aperture radar (SAR) sensor.

BACKGROUND ART

10 [0002]

In a synthetic aperture radar apparatus disclosed by Patent Literature 1 listed below, in order to make it possible to discriminate between a pulse signal emitted from an SAR sensor at a desired observation point and a pulse signal emitted from the SAR sensor at another observation point other than the desired observation point, the chirp of a pulse signal to be emitted into space is changed (switching between up-chirp and down-chirp is performed).

This makes it possible to reduce unavoidable range ambiguity in synthetic aperture observations.

CITATION LIST

PATENT LITERATURE

[0003]

Patent Literature 1: Japanese Patent Application
25 Publication No. 2003-167052 (for example, paragraph [0018])

SUMMARY OF INVENTION

TECHNICAL PROBLEM

[0004]

Because the conventional synthetic aperture radar
30 apparatus is configured as described above, although

unavoidable range ambiguity is reduced in synthetic aperture observations, a process of reconstructing an SAR image is not performed in consideration of a movement of the SAR sensor during a time period until a pulse signal is received by the SAR sensor after the pulse signal is emitted from the SAR sensor. 5 Therefore, when range compression is performed on the received signal of the SAR sensor in the process of reconstructing an SAR image, a peak shift of the distance between the SAR sensor and the target occurs in the received signal subjected to the range compression. As a result, there arises the problem that azimuth ambiguity occurs in the SAR image. 10

[0005]

Hereafter, a phenomenon in which azimuth ambiguity occurs in an SAR image will be explained concretely.

15 The conventional synthetic aperture radar apparatus performs the process of reconstructing an SAR image while assuming that the SAR sensor is standing still during a time period until a pulse signal is received by the SAR sensor after the pulse signal is emitted from the SAR sensor.

20 However, the SAR sensor is moving in actual observations. Because the frequency of the received signal of the SAR sensor varies from the frequency at the time of transmission due to a movement of this SAR sensor, when the synthetic aperture radar apparatus performs range compression that includes correlation 25 processing with the transmitted signal, there occurs a phenomenon in which, as a result, the peak position of the distance shown by the received signal subjected to the range compression (distance between the SAR sensor and the target) shifts from the original distance.

30 [0006]

Because this shift of the distance depends on both the chirp rate of the pulse signal at the time of transmission, and the Doppler frequency, when switching between up-chirp and down-chirp at the time of transmission of the pulse signal is performed for the purpose of the reduction of range ambiguity, the direction in which the distance is shifted is reversed in accordance with the sign of the chirp.

Particularly, in an observation method of changing the transmission direction of a pulse signal during observation (e.g., spotlight, sliding spotlight, TOPS (Terrain Observation by Progressive Scans) or the like), the absolute value of this shift becomes large because the Doppler frequency under observation is large.

[0007]

Figs. 5A and 5B are illustrations for explaining a shift in the peak position of the distance in accordance with the sign of the chirp.

Figs. 5A and 5B show variations in the distance R between the SAR sensor and a point target. The distance R has a minimum of R_0 and draws a parabolic locus. In Fig. 5B, the locus of points of the distance R is expressed by a broken line.

When the SAR sensor is standing still, the distance R shown by the received signal subjected to the range compression at each azimuth time (a time intermediate between the transmission and reception times of the pulse signal) is located on the parabolic locus. In Fig. 5B, the peak position of the distance R appears at a position shown by the symbol "o".

However, the distance R shown by the received signal subjected to the range compression is shifted in a range direction under the influence of the movement of the SAR sensor.

In Fig. 5B, the peak position of the distance R is shifted to a position shown by the symbol "●".

In observations in which the sign of the chirp is changed alternately, the shift direction of the peak position is reversed in accordance with the sign of the chirp, as shown in 5 Fig. 5B. Further, the shift direction is reversed with a change from positive to negative in the Doppler frequency.

The absolute value of this shift becomes large in proportion to the absolute value of the Doppler frequency. The absolute value of this shift is usually less than the range 10 sampling period, but amplitude modulation in the azimuth direction is made to occur in the arrangement in the azimuth direction along the locus of points of the distance R. This amplitude modulation in the azimuth direction causes azimuth 15 ambiguity to occur in the SAR image.

[0008]

The present invention is made in order to solve the above-mentioned problems, and it is therefore an object of the present invention to provide a synthetic aperture radar 20 apparatus capable of reconstructing an SAR image in which no azimuth ambiguity occurs.

SOLUTION TO PROBLEM

[0009]

According to the present invention, there is provided a 25 synthetic aperture radar apparatus which includes: a synthetic aperture radar sensor configured to emit chirp signals into space, each chirp signal having a frequency changing with time and a rate of change of the frequency being switched, and configured to receive reflected waves of the chirp signals which 30 are reflected by a target to thereby output received signals

of the reflected waves; and a signal processor including an image reconstruction processing means that is configured to perform range compression on the received signals outputted by the synthetic aperture radar sensor, and configured to reconstruct a synthetic aperture radar image from the received signals subjected to the range compression. The signal processor further includes a peak shift compensation means that is configured to compensate for a peak shift of a distance between the synthetic aperture radar sensor and the target, the peak shift occurring in the received signal subjected to the range compression performed by the image reconstruction processing means, due to a movement of the synthetic aperture radar sensor during a time period until the reflected waves of the chirp signals are received by the synthetic aperture radar sensor after the chirp signals are emitted from the synthetic aperture radar sensor.

ADVANTAGEOUS EFFECTS OF INVENTION

[0010]

Because the peak shift compensation means according to the present invention is configured so as to compensate for a peak shift of the distance between the synthetic aperture radar sensor and the target, the peak shift occurring in the received signal subjected to the range compression by the image reconstruction processing means due to a movement of the synthetic aperture radar sensor during a time period until the reflected wave of the chirp signal is received by the synthetic aperture radar sensor after the chirp signal is emitted from the synthetic aperture radar sensor, there is provided an advantage of being able to reconstruct a synthetic aperture radar image in which no azimuth ambiguity occurs.

BRIEF DESCRIPTION OF DRAWINGS

[0011]

Fig. 1 is a configuration diagram showing a synthetic aperture radar apparatus according to Embodiment 1 of the present invention;

Fig. 2 is a flow chart showing the details of processing performed by the synthetic aperture radar apparatus according to Embodiment 1 of the present invention;

Fig. 3 is a configuration diagram showing a synthetic aperture radar apparatus according to Embodiment 2 of the present invention;

Fig. 4 is a flow chart showing the details of processing performed by the synthetic aperture radar apparatus Embodiment 2 of the present invention; and

Figs. 5A and 5B are illustrations for explaining a shift of a peak position of a distance corresponding to the sign of a chirp.

DESCRIPTION OF EMBODIMENTS

[0012]

Hereafter, in order to explain this invention in greater detail, the preferred embodiments of the present invention will be described with reference to the accompanying drawings.

[0013]

Embodiment 1.

Fig. 1 is a configuration diagram showing a synthetic aperture radar apparatus according to Embodiment 1 of the present invention.

In the configuration shown in Fig. 1, an SAR sensor 1, which is a synthetic aperture radar sensor, emits chirp signals into space, each of the chirp signals having a frequency

changing with time, and a range chirp rate $K_r[\eta]$ (a rate of change of the frequency) which is changed at an azimuth time η (a time defined by signal transmission and reception times, e.g., a time intermediate between the transmission and reception times of the pulse signal), receives reflected waves of the above-mentioned chirp signals, the reflected waves being reflected by a target, and outputs received signals of the reflected waves.

More specifically, the SAR sensor 1 alternately emits, as the chirp signals, an up-chirp pulse signal having a frequency increasing with time and a down-chirp pulse signal having a frequency decreasing with time, into space while changing their transmission directions.

Further, when receiving a reflected wave of a pulse signal, the reflected wave being reflected by a target, the SAR sensor 1 carries out commonly used signal reception processes (e.g., a process of converting the frequency of a received signal of the reflected wave into an intermediate frequency, a process of performing A/D conversion on the frequency-converted received signal, etc.) on the received signal of the reflected wave, and outputs digital received data which is the received signal subjected to the signal reception processes, to the signal processor 2.

It is assumed that the SAR sensor 1 is moved while being mounted in a moving platform such as an airplane or a satellite.

[0014]

The signal processor 2 performs range compression on the digital received data outputted from the SAR sensor 1, and reconstructs an SAR image (i.e., a synthetic aperture radar image) from the received data subjected to the range

compression.

The signal processor 2 also performs a process of compensating for a peak shift of the distance R between the SAR sensor 1 and the target, the peak shift occurring in the received signal subjected to the range compression due to a movement of the SAR sensor 1 during a time period until the reflected wave of the pulse signal is received by the SAR sensor 1 after the pulse signal is emitted from the SAR sensor 1.

[0015]

10 A range DFT unit 11 of the signal processor 2 is comprised of, for example, either a semiconductor integrated circuit equipped with a CPU (Central Processing Unit), or a one chip microcomputer, and carries out a process of performing a discrete Fourier transform, in a range direction, on the digital received data outputted from the SAR sensor 1, and outputting the received data subjected to the discrete Fourier transform to a function value multiplier 12. The range DFT unit 11 constructs a Fourier transform unit.

20 The function value multiplier 12 of the signal processor 2 is comprised of, for example, either a semiconductor integrated circuit equipped with a CPU, or a one chip microcomputer, and performs a process of multiplying the received data subjected to the discrete Fourier transform in the range DFT unit 11, by the function value $C[f_r, \eta]$ of a complex function in which an amount of compensation for the peak shift is determined from both the range chirp rate $K_r[\eta]$ at the azimuth time η , and an azimuth angle $\theta[\eta]$ in the transmission direction of the pulse signal at the azimuth time η .

[0016]

30 A range IDFT unit 13 of the signal processor 2 is comprised

of, for example, either a semiconductor integrated circuit equipped with a CPU, or a one chip microcomputer, and carries out a process of performing a discrete inverse Fourier transform, in the range direction, on the received data which is multiplied
5 by the function value by the function value multiplier 12, and outputting the received data subjected to the discrete inverse Fourier transform, to an image reconstruction processing unit 14. The range IDFT unit 13 constructs an inverse Fourier transform unit.

10 A peak shift compensation means is comprised of the range DFT unit 11, the function value multiplier 12 and the range IDFT unit 13.

The image reconstruction processing unit 14 of the signal processor 2 is comprised of, for example, either a semiconductor
15 integrated circuit equipped with a CPU, or a one chip microcomputer, and carries out a process of performing range compression on the received data outputted from the range IDFT unit 13, and reconstructing an SAR image from the received data subjected to the range compression. The image reconstruction
20 processing unit 14 constructs an image reconstruction processing means.

An SAR image storage 15 of the signal processor 2 is comprised of a storage unit, such as a RAM or a hard disk, and stores the SAR image reconstructed by the image reconstruction
25 processing unit 14.

[0017]

In the example of Fig. 1, it is assumed that the range DFT unit 11, the function value multiplier 12, the range IDFT unit 13, the image reconstruction processing unit 14 and the
30 SAR image storage 15, which are the components of the signal

processor 2, are comprised of pieces of hardware for exclusive use, respectively. As an alternative, the signal processor 2 can be comprised of a computer.

In the case in which the signal processor 2 is comprised of a computer, the SAR image storage 15 can be configured on a memory of the computer, and a program in which the details of processes performed by the range DFT unit 11, the function value multiplier 12, the range IDFT unit 13 and the image reconstruction processing unit 14 are described can be stored in a memory of the computer and a CPU of the computer can be made to execute the program stored in the memory.

Fig. 2 is a flow chart showing the details of processing performed by the synthetic aperture radar apparatus according to Embodiment 1 of the present invention.

15 [0018]

Next, operations will be explained.

The SAR sensor 1 alternately emits an up-chirp pulse signal having a frequency increasing with time and a down-chirp pulse signal having a frequency decreasing with time, into space, while changing their transmission directions, as shown in Fig. 5A.

Although in this Embodiment 1 the example of alternately emitting an up-chirp pulse signal and a down-chirp pulse signal into space is explained, the SAR sensor does not necessarily have to alternately emit an up-chirp pulse signal and a down-chirp pulse signal. As an alternative, the SAR sensor can continuously emit down-chirp pulse signals for multiple times after continuously emitting up-chirp pulse signals for multiple times.

30 As an alternative, the SAR sensor can repeatedly emit only

either an up-chirp pulse signal or a down-chirp pulse signal while changing the range chirp rate $K_r[\eta]$ at the azimuth time η .

Switching between up-chirp and down-chirp in pulse signals can be implemented by changing the sign of the range
5 chirp rate $K_r[\eta]$ at the azimuth time η .

[0019]

Further, after emitting a pulse signal, when receiving a reflected wave of the pulse signal, the reflected wave being
10 reflected by a target and then returning thereto, the SAR sensor 1 performs the commonly used signal reception processes (e.g., the process of converting the frequency of a received signal of the reflected wave into an intermediate frequency, and the process of performing A/D conversion on the frequency-converted
15 received signal, etc.) on the received signal of the reflected wave, and outputs digital received data which is the received signal subjected to the signal reception processes, to the signal processor 2 (in step ST1 of Fig. 2).

[0020]

20 When receiving the digital received data from the SAR sensor 1, the range DFT unit 11 of the signal processor 2 performs a discrete Fourier transform, in the range direction, on the received data and outputs the received data subjected to the discrete Fourier transform, to the function value multiplier
25 12, in order to make it possible to perform the process of compensating for a peak shift on range frequency space (in step ST2).

[0021]

The function value multiplier 12 of the signal processor
30 2 holds the complex function in which the amount of compensation

for the peak shift is determined from both the range chirp rate $K_r[\eta]$ at the azimuth time η , and the azimuth angle $\theta[\eta]$ in the transmission direction of the pulse signal at the azimuth time η , as shown in the following equation (1).

$$C[f_r, \eta] = \exp \left[j2\pi f_r \frac{f_0 - \frac{2v_s \sin \theta[\eta]}{c}}{K_r[\eta]} \right] \quad (1)$$

In the equation (1), f_r denotes the range frequency (the frequency of the received signal of the SAR sensor 1), f_0 denotes the center frequency of the pulse signal, v_s denotes the moving speed of the moving platform in which the SAR sensor 1 is mounted, and c denotes the speed of light.

The term $f_0/K_r[\eta]$ and the term $2v_s \sin \theta[\eta]/c$ in the complex function shown by the equation (1) contribute to the compensation for the peak shift.

[0022]

When receiving the received data subjected to the discrete Fourier transform from the range DFT unit 11, the function value multiplier 12 acquires information showing the range chirp rate $K_r[\eta]$ of the pulse signal emitted at the azimuth time η , information showing the azimuth angle $\theta[\eta]$ in the transmission direction of the pulse signal, information showing the range frequency f_r , information showing the center frequency f_0 of the pulse signal, and information showing the moving speed v_s of the moving platform from, for example, the SAR sensor 1, and substitutes the range chirp rate $K_r[\eta]$, the azimuth angle $\theta[\eta]$ in the transmission direction, the range frequency f_r , the center frequency f_0 , the moving speed v_s , and the speed of light c into the complex function shown by the equation (1), thereby calculating the function value $C[f_r, \eta]$ of the complex function.

Although the example in which the function value

multiplier 12 of the signal processor 2 acquires the above-mentioned pieces of information from the SAR sensor 1 is shown above, the function value multiplier does not have to acquire the above-mentioned pieces of information from the SAR sensor 1 in a case in which the signal processor 2 manages the above-mentioned pieces of information and controls the SAR sensor 1.

[0023]

After calculating the function value $C[f_r, \eta]$ of the complex function, the function value multiplier 12 multiplies the received data subjected to the discrete Fourier transform outputted from the range DFT unit 11 by the function value $C[f_r, \eta]$, thereby compensating for the peak shift of the distance R , the peak shift occurring in the received signal subjected to the range compression, and outputs the received data subjected to the function value multiplication, to the range IDFT unit 13 (in step ST3).

Although the example of compensating for the peak shift of the distance R by multiplying the received data subjected to the discrete Fourier transform by the function value $C[f_r, \eta]$ of the complex function shown by the equation (1) is shown above, the peak shift of the distance R can be compensated for by alternatively multiplying the received data subjected to the discrete Fourier transform by the function value of even a function other than that shown by the equation (1), as long as the function has a function of compensating for the peak shift of the distance R (as long as the function has a linear phase change), like the complex function shown by the equation (1).

[0024]

When receiving the received data subjected to the

function value multiplication, the range IDFT unit 13 of the signal processor 2 performs a discrete inverse Fourier transform, in the range direction, on the received data in order to return the received data to a signal on range time space, and outputs the received data subjected to the discrete inverse Fourier transform, to the image reconstruction processing unit 14 (in step ST4).

Although the example of performing the process of compensating for the peak shift on the range frequency space is shown above, the signal processor can alternatively perform a process of compensating for the peak shift on the range time space.

In this case, instead of disposing the range DFT unit 11 and the range IDFT unit 13, the function value multiplier 12 time-shifts the received data outputted from the SAR sensor 1 by $(f_0/K_r[\eta]) \cdot (2v_s \sin\theta[\eta]/c)$ which contributes to the compensation for the peak shift.

[0025]

When receiving the received data subjected to the process of compensating for the peak shift from the range IDFT unit 13, the image reconstruction processing unit 14 of the signal processor 2 reconstructs an SAR image by performing commonly used image reconstruction processing, such as range compression and azimuth compression, on the received data (in step ST5) and stores the SAR image in the SAR image storage 15 (in step ST6).

Although a detailed explanation of the process of reconstructing an SAR image will be omitted hereafter because the process of reconstructing an SAR image is a commonly used technique, a peak shift of the distance R does not occur in the received data subjected to the range compression (even if a peak

shift of the distance R remains, the peak shift is substantially close to zero) and the distance R shown by the received signal subjected to the range compression appears at a position shown by the symbol "O" in Fig. 5B or at a position close to the position shown by the symbol "O" because, in the image reconstruction processing, the range compression is performed on the received data subjected to the process of compensating for a peak shift.

[0026]

As can be seen from the above description, because the synthetic aperture radar apparatus according to Embodiment 1 is configured so as to compensate for a peak shift of the distance R between the SAR sensor 1 and a target, the peak shift occurring in the received signal subjected to the range compression performed by the image reconstruction processing unit 14, due to a movement of the SAR sensor 1 during a time period until a reflected wave of a pulse signal is received by the SAR sensor 1 after the pulse signal is emitted from the SAR sensor 1, there is an advantage of being able to reconstruct an SAR image in which no azimuth ambiguity occurs.

[0027]

Further, because the synthetic aperture radar apparatus according to Embodiment 1 compensates for the peak shift of the distance R occurring in the received signal subjected to the range compression by simply causing the function value multiplier 12 to multiply the received data subjected to a discrete Fourier transform by the function value $C[f_r, \eta]$ of a complex function, the function value multiplier can be easily incorporated into an existing synthetic aperture radar apparatus. Further, the occurrence of azimuth ambiguity can be prevented almost without increasing the arithmetic load.

In addition, because the synthetic aperture radar apparatus compensates for the peak shift of the distance between the SAR sensor 1 and the target for each azimuth time, the synthetic aperture radar apparatus can deal with switching, using interpulse modulation, to an arbitrary range chirp rate for each azimuth time.

[0028]

Although the example in which the function value multiplier 12 compensates for the peak shift of the distance before the image reconstruction processing unit 14 performs the image reconstruction processing is shown in this Embodiment 1, the image reconstruction processing unit 14 can be configured so as to compensate for the peak shift of the distance, by incorporating the process of performing a discrete Fourier transform, in the range direction, on the received data, the process of multiplying the received data subjected to the discrete Fourier transform by the function value $C[f_r, \eta]$ of the complex function, and the process of performing a discrete inverse Fourier transform, in the range direction, on the received data into the image reconstruction processing performed by the image reconstruction processing unit 14.

[0029]

Embodiment 2.

With respect to the above-described Embodiment 1, the example of alternately emitting an up-chirp pulse signal and a down-chirp pulse signal into space has been explained. With respect to Embodiment 2, an example of continuously emitting down-chirp pulse signals for multiple times after continuously emitting up-chirp pulse signals for multiple times will be explained.

The number of times that up-chirp pulse signals are continuously emitted and the number of times that down-chirp pulse signals are continuously emitted can be fixed or variable.

[0030]

5 Fig. 3 is a configuration diagram showing a synthetic aperture radar apparatus according to Embodiment 2 of the present invention. In Fig. 3, because the same reference numerals as those shown in Fig. 1 denote the same components or like components, the explanation of the components will be
10 omitted hereafter.

A segmentation unit 21 of a signal processor 2 is comprised of, for example, either a semiconductor integrated circuit equipped with a CPU, or a one chip microcomputer, and performs a process of segmenting digital received data outputted from
15 an SAR sensor 1 into segments in an azimuth direction for each section in which pulse signals having an identical range chirp rate are continuously emitted.

[0031]

An azimuth DFT unit 22 of the signal processor 2 is
20 comprised of, for example, either a semiconductor integrated circuit equipped with a CPU, or a one chip microcomputer, and carries out a process of performing a discrete Fourier transform, in an azimuth direction, on each of received signals in an identical segment after being segmented by the segmentation
25 unit 21, and outputting the received data subjected to the discrete Fourier transform to a range DFT unit 23.

The range DFT unit 23 of the signal processor 2 is
30 comprised of, for example, either a semiconductor integrated circuit equipped with a CPU, or a one chip microcomputer, and carries out a process of performing a discrete Fourier transform,

in a range direction, on the received data outputted from the azimuth DFT unit 22, and outputting the received data subjected to the discrete Fourier transform, to a function value multiplier 24.

5 A Fourier transform unit is comprised of the azimuth DFT unit 22 and the range DFT unit 23.

The example in which the range DFT unit 23 performs a discrete Fourier transform in the range direction after the azimuth DFT unit 22 performs a discrete Fourier transform in the azimuth direction is shown in Fig. 3. As an alternative,
10 the azimuth DFT unit 22 can perform a discrete Fourier transform in the azimuth direction after the range DFT unit 23 performs a discrete Fourier transform in the range direction.

[0032]

15 The function value multiplier 24 of the signal processor 2 is comprised of, for example, either a semiconductor integrated circuit equipped with a CPU, or a one chip microcomputer, and performs a process of multiplying the received data subjected to the discrete Fourier transform in the range DFT unit 23, by the function value $C[f_r, f_n]$ of a complex
20 function in which the amount of compensation for a peak shift is determined from the range chirp rate in the segment in the azimuth direction to which the received data outputted from the range DFT unit 23 belongs, and an azimuth frequency f_n (Doppler
25 frequency).

[0033]

A range IDFT unit 25 of the signal processor 2 is comprised of, for example, either a semiconductor integrated circuit equipped with a CPU, or a one chip microcomputer, and carries
30 out a process of performing a discrete inverse Fourier transform,

in the range direction, on the received data which is multiplied by the function value by the function value multiplier 24, and outputting the received data subjected to the discrete inverse Fourier transform, to an azimuth IDFT unit 26.

5 The azimuth IDFT unit 26 of the signal processor 2 is comprised of, for example, either a semiconductor integrated circuit equipped with a CPU, or a one chip microcomputer, and carries out a process of performing a discrete inverse Fourier transform, in the azimuth direction, on the received data
10 outputted from the range IDFT unit 25, and outputting the received data subjected to the discrete inverse Fourier transform, to a segment combiner 27.

 An inverse Fourier transform unit is comprised of the range IDFT unit 25 and the azimuth IDFT unit 26.

15 The example in which the azimuth IDFT unit 26 performs a discrete inverse Fourier transform in the azimuth direction after the range IDFT unit 25 performs a discrete inverse Fourier transform in the range direction is shown in Fig. 3. As an alternative, the range IDFT unit 25 can perform a discrete
20 inverse Fourier transform in the range direction after the azimuth IDFT unit 26 performs a discrete inverse Fourier transform in the azimuth direction.

[0034]

 The segment combiner 27 of the signal processor 2 is
25 comprised of, for example, either a semiconductor integrated circuit equipped with a CPU, or a one chip microcomputer, and performs a process of combining received data belonging to an identical segment and outputted from the azimuth IDFT unit 26, and outputting received data subjected to the combining, to an
30 image reconstruction processing unit 14.

A peak shift compensation means is comprised of the segmentation unit 21, the azimuth DFT unit 22, the range DFT unit 23, the function value multiplier 24, the range IDFT unit 25, the azimuth IDFT unit 26 and the segment combiner 27.

5 [0035]

In the example of Fig. 3, it is assumed that the segmentation unit 21, the azimuth DFT unit 22, the range DFT unit 23, the function value multiplier 24, the range IDFT unit 25, azimuth IDFT unit 26, the segment combiner 27, the image reconstruction processing unit 14 and an SAR image storage 15, which are the components of the signal processor 2, are comprised of pieces of hardware for exclusive use. As an alternative, the signal processor 2 can be comprised of a computer.

15 In the case in which the signal processor 2 is comprised of a computer, the SAR image storage 15 can be configured on a memory of the computer, and a program in which the details of processes performed by the segmentation unit 21, the azimuth DFT unit 22, the range DFT unit 23, the function value multiplier 24, the range IDFT unit 25, the azimuth IDFT unit 26, the segment combiner 27 and the image reconstruction processing unit 14 are described can be stored in a memory of the computer and a CPU of the computer can be made to execute the program stored in the memory.

25 Fig. 4 is a flow chart showing the details of processing performed by the synthetic aperture radar apparatus according to Embodiment 2 of the present invention.

[0036]

Next, operations will be explained.

30 The SAR sensor 1 emits either up-chirp pulse signals or

down-chirp pulse signals into space while changing their transmission directions, as shown in Fig. 5A.

In this Embodiment 2, a section in which the SAR sensor continuously emits up-chirp pulse signals for multiple times and a section in which the SAR sensor continuously emits down-chirp pulse signals for multiple times are provided, and the SAR sensor switches between these sections.

In the present Embodiment, the example in which a section in which the SAR sensor continuously emits up-chirp pulse signals for multiple times and a section in which the SAR sensor continuously emits down-chirp pulse signals for multiple times are provided. A section in which the SAR sensor continuously emits pulse signals whose range chirp rate is set to a first value for multiple times and a section in which the SAR sensor continuously emits pulse signals whose range chirp rate is set to a second value for multiple times can be provided, and the SAR sensor can switch between these sections.

[0037]

After emitting a pulse signal, when receiving a reflected wave of the pulse signal, the reflected wave being reflected by a target and then returning thereto, the SAR sensor 1 performs commonly used signal reception processes on the received signal of the reflected wave, and outputs digital received data which is the received signal subjected to the signal reception processes, to the signal processor 2 (in step ST21 of Fig. 4), like that according to above-mentioned Embodiment 1.

[0038]

When receiving the digital received data from the SAR sensor 1, the segmentation unit 21 of the signal processor 2 segments the digital received data outputted from the SAR sensor

1 into segments in the azimuth direction for each section in which pulse signals having an identical range chirp rate are continuously emitted (in step ST22).

For example, in a case in which the SAR sensor 1 is set up in such a way as to continuously emit down-chirp pulse signals for four times after continuously emitting up-chirp pulse signals for three times, the segmentation unit segments three pieces of received data about the up-chirp pulse signals, into segments in the azimuth direction, and also segments four pieces of received data about the down-chirp pulse signals, into segments in the azimuth direction.

[0039]

After the segmentation unit 21 segments the digital received data outputted from the SAR sensor 1 into segments in the azimuth direction, the azimuth DFT unit 22 of the signal processor 2 performs a discrete Fourier transform, in the azimuth direction, on each of the received signals belonging to an identical segment in order to make it possible to perform a process of compensating for a peak shift on two-dimensional frequency space (azimuth frequency/range frequency space), and outputs the received data subjected to the discrete Fourier transform, to the range DFT unit 23 (in step ST23).

When receiving the received data from the azimuth DFT unit 22, the range DFT unit 23 of the signal processor 2 performs a discrete Fourier transform, in the range direction, on the received data and outputs the received data subjected to the discrete Fourier transform, to the function value multiplier 24 (in step ST24).

[0040]

The function value multiplier 24 of the signal processor

2 holds the complex function in which the amount of compensation for a peak shift is determined from both the range chirp rate K_r bar in the segment in the azimuth direction to which the received data belongs and the azimuth frequency f_η , as shown
 5 in the following equation (2) (please note that, in the document of this description, such expression " K_r bar" is used because the over-bar character "-" cannot be attached to any letters under the restrictions on electronic filing).

$$C[f_\tau, f_\eta] = \exp[j2\pi f_\tau \frac{f_\eta}{K_r}] \quad (2)$$

10 The term $f_\eta/[K_r \text{ bar}]$ contributes to the compensation for a peak shift in the complex function shown by the equation (2).
 [0041]

When receiving the received data subjected to the discrete Fourier transform from the range DFT unit 23, the
 15 function value multiplier 24 acquires information showing the range chirp rate K_r bar in the segment in the azimuth direction to which the pulse signal emitted at an azimuth time η belongs, information showing the azimuth frequency f_η , and information showing a range frequency f_τ from the SAR sensor 1, and
 20 substitutes the range chirp rate K_r bar, the azimuth frequency f_η and the range frequency f_τ into the complex function shown by the equation (2), thereby calculating the function value $C[f_\tau, f_\eta]$ of the complex function.

Although the example in which the function value
 25 multiplier 24 of the signal processor 2 acquires the above-mentioned pieces of information from the SAR sensor 1 is shown above, the function value multiplier does not have to acquire the above-mentioned pieces of information from the SAR sensor 1 in a case in which the signal processor 2 manages the

above-mentioned pieces of information and controls the SAR sensor 1.

[0042]

After calculating the function value $C[f_r, f_n]$ of the complex function, the function value multiplier 24 multiplies the received data subjected to the discrete Fourier transform outputted from the range DFT unit 23, by the function value $C[f_r, f_n]$, thereby compensating for the peak shift of the distance R , the peak shift occurring in the received signal subjected to the range compression, and outputs the received data subjected to the function value multiplication, to the range IDFT unit 25 (in step ST25).

Although the example of compensating for the peak shift of the distance R by multiplying the received data subjected to the discrete Fourier transform by the function value $C[f_r, f_n]$ of the complex function shown by the equation (2) is shown above, the peak shift of the distance R can be compensated for by alternatively multiplying the received data subjected to the discrete Fourier transform by the function value of even a function other than that shown by the equation (2), as long as the function has a function of compensating for the peak shift of the distance R (as long as the function has a linear phase change), like the complex function shown by the equation (2).

[0043]

When receiving the received data subjected to the function value multiplication, the range IDFT unit 25 of the signal processor 2 performs a discrete inverse Fourier transform, in the range direction, on the received data and outputs the received data subjected to the discrete inverse Fourier transform, to the azimuth IDFT unit 26, in order to

return the received data to a signal on range time space (in step ST26).

When receiving the received data from the range IDFT unit 25, the azimuth IDFT unit 26 of the signal processor 2 performs
5 a discrete inverse Fourier transform, in the azimuth direction, on the received data and outputs the received data subjected to the discrete inverse Fourier transform, to the segment combiner 27 (in step ST27).

[0044]

10 When the range IDFT unit 25 and the azimuth IDFT unit 26 return the received data to a signal on the range time space, the segment combiner 27 of the signal processor 2 combines the received data belonging to an identical segment in the azimuth direction, and outputs the received data subjected to the
15 combining, to the image reconstruction processing unit 14 (in step ST28).

When receiving the received data subjected to the process of compensating for the peak shift from the segment combiner 27, the image reconstruction processing unit 14 of the signal
20 processor 2 reconstructs an SAR image by performing commonly used image reconstruction processing, such as range compression and azimuth compression, on the received data (in step ST29) and stores the SAR image in the SAR image storage 15 (in step ST30), that according to above-mentioned Embodiment 1.

25 A peak shift of the distance R does not occur in the received data subjected to the range compression and the distance R shown by the received signal subjected to the range compression appears at a position shown by the symbol "o" in Fig. 5B because, in the image reconstruction processing, the
30 range compression is performed on the received data subjected

to the process of compensating for a peak shift.

[0045]

As can be seen from the above description, because the synthetic aperture radar apparatus according to this Embodiment 5 2 compensates for a peak shift of the distance R occurring in the received signal subjected to the range compression by simply causing the function value multiplier 24 to multiply the received data subjected to a discrete Fourier transform by the function value $C[f_r, f_n]$ of a complex function in range 10 frequency/azimuth frequency space, Embodiment 2 provides an advantage of being able to reconstruct an SAR image in which no azimuth ambiguity occurs, like above-mentioned Embodiment 1, even when down-chirp pulse signals are continuously emitted for multiple times after up-chirp pulse signals are 15 continuously emitted for multiple times.

Further, the function value multiplier can be easily incorporated into an existing synthetic aperture radar apparatus. Further, the occurrence of azimuth ambiguity can be prevented almost without increasing the arithmetic load.

20 [0046]

While the invention has been described in its preferred embodiments, it is to be understood that an arbitrary combination of two or more of the above-mentioned embodiments can be made, various changes can be made in an arbitrary 25 component in accordance with any one of the above-mentioned embodiments, and an arbitrary component in accordance with any one of the above-mentioned embodiments can be omitted within the scope of the invention.

INDUSTRIAL APPLICABILITY

30 [0047]

The synthetic aperture radar apparatus according to the present invention is suitable for use as a synthetic aperture radar apparatus that needs to compensate for a peak shift of a distance occurring in the received signal subjected to range compression due to a movement of an SAR sensor 1, and reconstruct a high-accuracy SAR image.

REFERENCE SIGNS LIST

[0048]

1: SAR sensor (synthetic aperture radar sensor); 2: signal processor; 11: range DFT unit (Fourier transform unit; peak shift compensation means); 12: function value multiplier (peak shift compensation means); 13: range IDFT unit (inverse Fourier transform unit, peak shift compensation means); 14: image reconstruction processing unit (image reconstruction processing means); 15: SAR image storage; 21: segmentation unit (peak shift compensation means); 22: azimuth DFT unit (Fourier transform unit, peak shift compensation means); 23: range DFT unit (Fourier transform unit, peak shift compensation means); 24: function value multiplier (peak shift compensation means); 20 25: range IDFT unit (inverse Fourier transform unit, peak shift compensation means); 26: azimuth IDFT unit (inverse Fourier transform unit, peak shift compensation means); and 27: segment combiner (peak shift compensation means).

CLAIMS

1. A synthetic aperture radar apparatus comprising:
 - a synthetic aperture radar sensor configured to emit
5 chirp signals into space, said each chirp signal having a
frequency changing with time and a rate of change of said
frequency being switched, and configured to receive reflected
waves of said chirp signals which are reflected by a target to
thereby output received signals of said reflected waves; and
 - 10 a signal processor including an image reconstruction
processing means that is configured to perform range
compression on the received signals outputted by said synthetic
aperture radar sensor, and configured to reconstruct a
synthetic aperture radar image from the received signals
15 subjected to the range compression,
 - said signal processor further including a peak shift
compensation means that is configured to compensate for a peak
shift of a distance between said synthetic aperture radar sensor
and said target, the peak shift occurring in the received signal
20 subjected to the range compression performed by said image
reconstruction processing means, due to a movement of said
synthetic aperture radar sensor during a time period until the
reflected waves of the chirp signals are received by said
synthetic aperture radar sensor after said chirp signals are
25 emitted from said synthetic aperture radar sensor.
2. The synthetic aperture radar apparatus according to claim
1, wherein said synthetic aperture radar sensor emits said chirp
signals while changing transmission directions of said chirp
30 signals.

3. The synthetic aperture radar apparatus according to claim 1, wherein said synthetic aperture radar sensor emits, as said each chirp signal, either an up-chirp pulse signal having a frequency increasing with time or a down-chirp pulse signal having a frequency decreasing with time, into space.

4. The synthetic aperture radar apparatus according to claim 1, wherein said peak shift compensation means includes:

10 a Fourier transform unit configured to perform a Fourier transform in a range direction on the received signals outputted from said synthetic aperture radar sensor;

a function value multiplier configured to multiply the received signals subjected to the Fourier transform in said Fourier transform unit, by function values of a complex function in which an amount of compensation for said peak shift is determined from both the rate of change of said frequency and transmission directions of said chirp signals; and

20 an inverse Fourier transform unit configured to perform an inverse Fourier transform in the range direction on the received signals obtained by the multiplication of the function value performed by said function value multiplier, and configured to output the received signals subjected to the inverse Fourier transform, to said image reconstruction processing means.

5. The synthetic aperture radar apparatus according to claim 1, wherein said peak shift compensation means includes:

30 a segmentation unit configured to segment the received signals outputted by said synthetic aperture radar sensor into

segments in an azimuth direction, for each section in which chirp signals having an identical rate of change of said frequency are continuously emitted;

5 a Fourier transform unit configured to perform a Fourier transform both in an azimuth direction and in the range direction on the received signals subjected to the segmentation in said segmentation unit;

10 a function value multiplier configured to multiply each of the received signals subjected to the Fourier transform in said Fourier transform unit, by function values of a complex function in which an amount of compensation for said peak shift is determined from both the rate of change of said frequency in the segment to which said received signals belong, and Doppler frequencies of said received signals;

15 an inverse Fourier transform unit configured to perform an inverse Fourier transform both in the azimuth direction and in the range direction on the received signals subjected to the multiplication by the function value in said function value multiplier; and

20 a segment combiner configured to combine the received signals belonging to an identical segment and subjected to the inverse Fourier transform in said inverse Fourier transform unit, and configured to output the combined received signals to said image reconstruction processing means.

FIG. 1

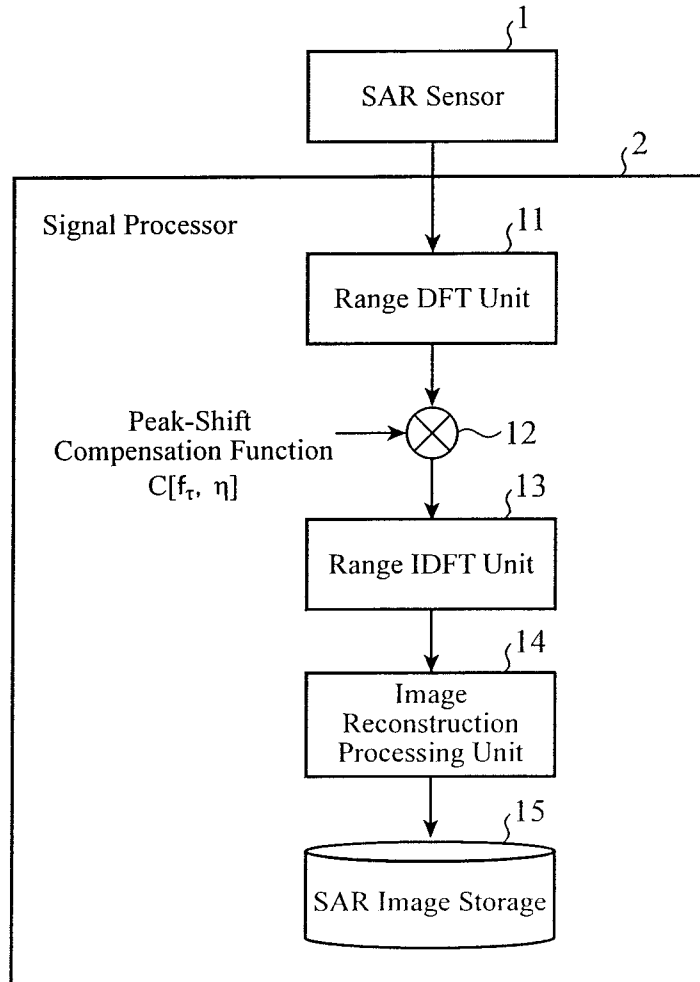
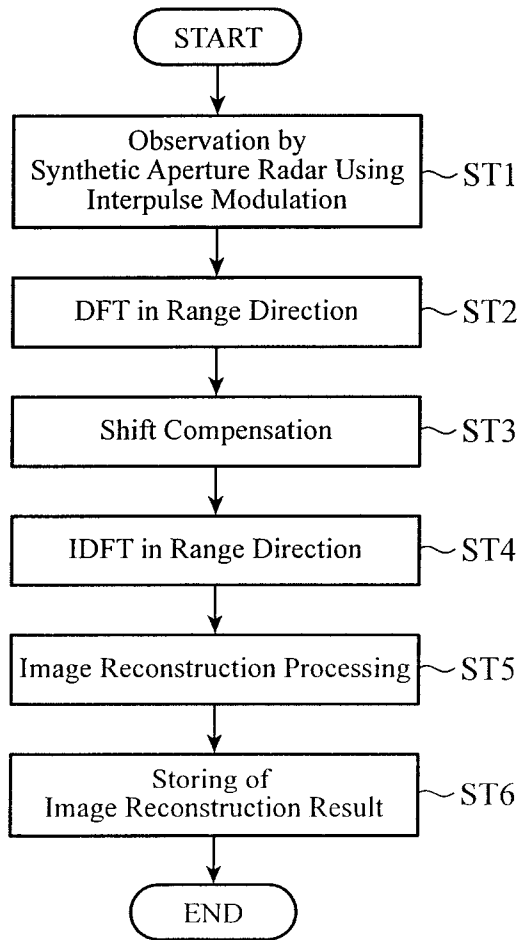

FIG.2



3/5

FIG.3

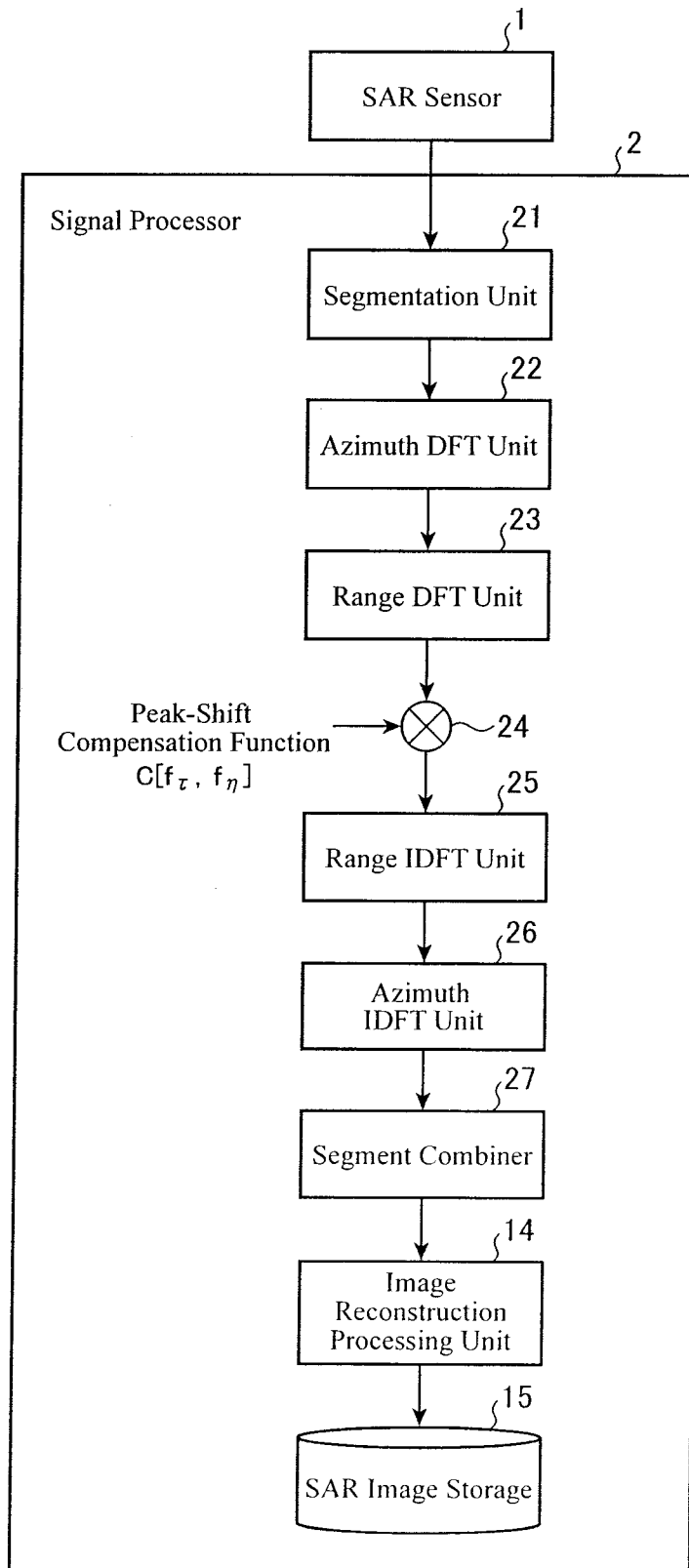
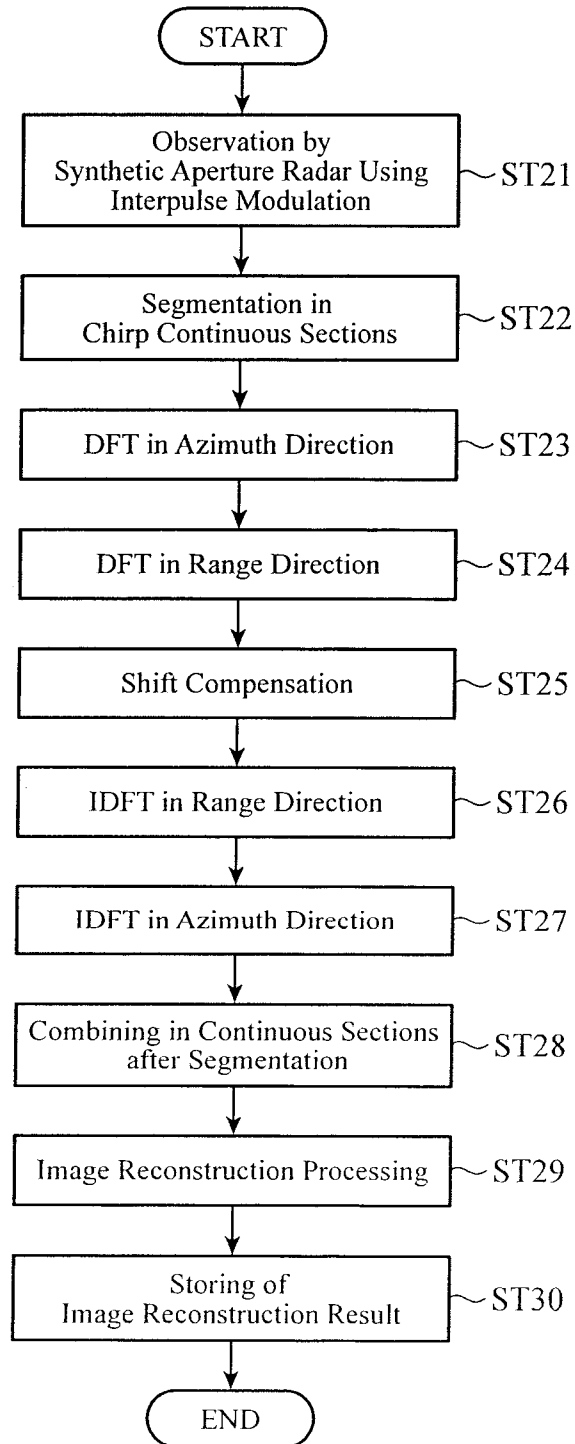
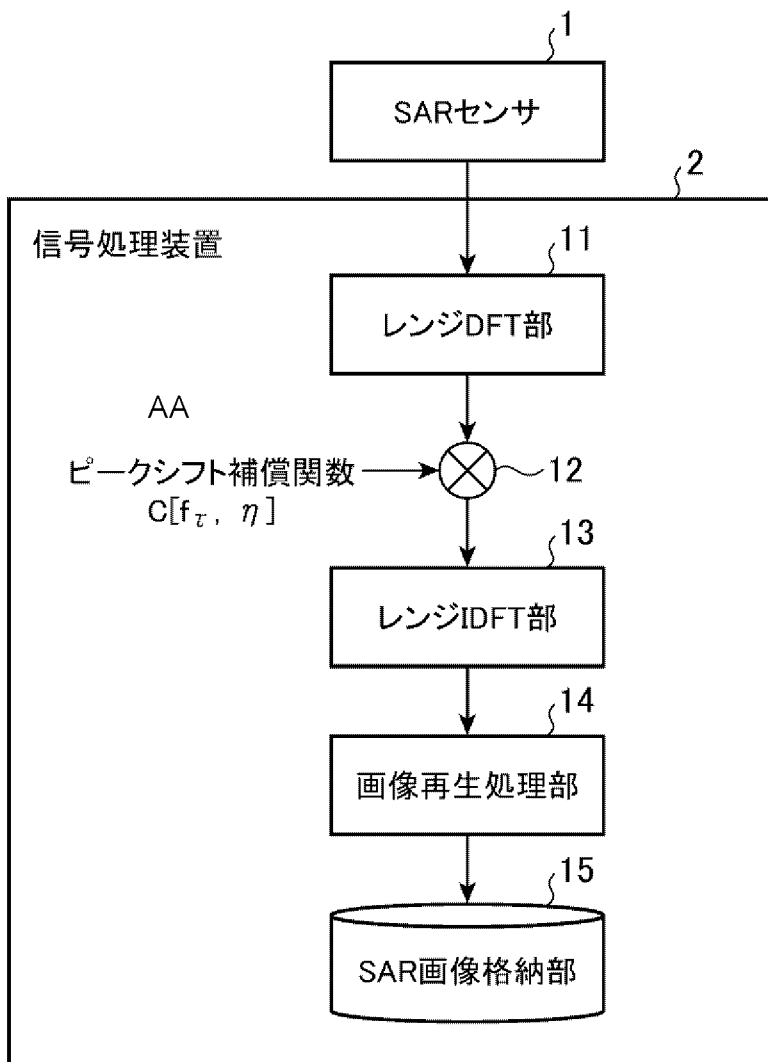

FIG.4





- 1 SAR sensor
- 2 Signal processing device
- 11 Range DFT unit
- 13 Range IDFT unit
- 14 Image reproduction processing unit
- 15 SAR image storage unit
- AA Peak shift compensation function