



(51) International Patent Classification:  
B65D 17/28 (2006.01)

(21) International Application Number:  
PCT/EP2019/054439

(22) International Filing Date:  
22 February 2019 (22.02.2019)

(25) Filing Language: English

(26) Publication Language: English

(30) Priority Data:  
102018000003019 26 February 2018 (26.02.2018) IT

(72) Inventor; and

(71) Applicant: **FERRERO, Stefano** [IT/IT]; Piazza Vittorio Emanuele II,55, 12060 Farigliano (IT).

(74) Agent: **MODIANO, Micaela**; Modiano & Partners, Via Meravigli, 16, 20123 Milano (IT).

(81) Designated States (unless otherwise indicated, for every kind of national protection available): AE, AG, AL, AM, AO, AT, AU, AZ, BA, BB, BG, BH, BN, BR, BW, BY, BZ, CA, CH, CL, CN, CO, CR, CU, CZ, DE, DJ, DK, DM, DO, DZ, EC, EE, EG, ES, FI, GB, GD, GE, GH, GM, GT, HN, HR, HU, ID, IL, IN, IR, IS, JO, JP, KE, KG, KH, KN, KP, KR, KW, KZ, LA, LC, LK, LR, LS, LU, LY, MA, MD, ME, MG, MK, MN, MW, MX, MY, MZ, NA, NG, NI, NO, NZ,

OM, PA, PE, PG, PH, PL, PT, QA, RO, RS, RU, RW, SA, SC, SD, SE, SG, SK, SL, SM, ST, SV, SY, TH, TJ, TM, TN, TR, TT, TZ, UA, UG, US, UZ, VC, VN, ZA, ZM, ZW.

(84) Designated States (unless otherwise indicated, for every kind of regional protection available): ARIPO (BW, GH, GM, KE, LR, LS, MW, MZ, NA, RW, SD, SL, ST, SZ, TZ, UG, ZM, ZW), Eurasian (AM, AZ, BY, KG, KZ, RU, TJ, TM), European (AL, AT, BE, BG, CH, CY, CZ, DE, DK, EE, ES, FI, FR, GB, GR, HR, HU, IE, IS, IT, LT, LU, LV, MC, MK, MT, NL, NO, PL, PT, RO, RS, SE, SI, SK, SM, TR), OAPI (BF, BJ, CF, CG, CI, CM, GA, GN, GQ, GW, KM, ML, MR, NE, SN, TD, TG).

Published:  
— with international search report (Art. 21(3))

(54) Title: BEVERAGE CAN

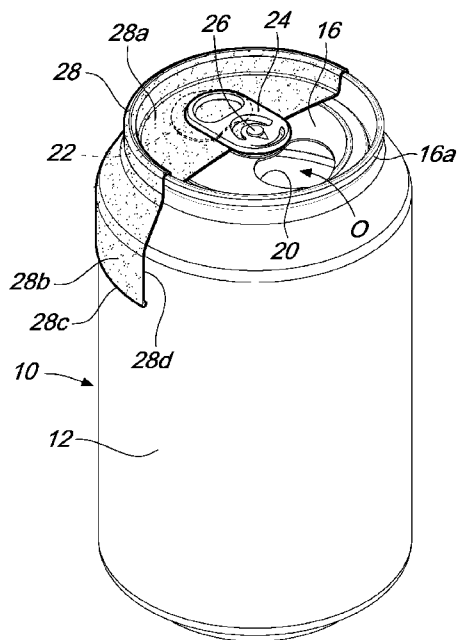

Fig. 2

(57) Abstract: A cylindrical wall (12) is closed at its opposite ends by a bottom (14) and by a lid (16) made of thin sheet metal, which is provided with an incision (20) with a closed profile so as to form internally a tab (22) which can be separated by pressing from the material of the lid (16). A screen (28) made of thin flexible material is applied to the lid (16), is fixed to the tab (22), and can be moved between a first position, in which it covers the incision (20), and a second position, in which it exposes the incision (20).



## BEVERAGE CAN

The present invention relates to a can for beverages such as colas, sodas, fizzy drinks, beers, teas, energy drinks, and the like.

As is known, a generic can is constituted by a cylindrical container  
5 made of thin sheet metal, for example tinned iron plate or, more recently, aluminum, closed at its opposite ends by a bottom and by a lid made of the same material.

In aluminum cans, the cylindrical wall and the bottom can be formed monolithically by drawing. The lid is usually applied separately by seaming  
10 and is provided with a lever-type opening mechanism which cannot be reclosed.

In this regard, the lid is typically provided with an incision with a concave profile, which forms internally a tab.

A ring-shaped lever is coupled to the lid proximate to a region in  
15 which the incision is interrupted, so as to form substantially a first-order lever; in practice, by lifting one side of the ring, the opposite side pushes the tab toward the inside of the can, opening it, with a cut along the entire profile of the incision.

The opening mechanism described above has drawbacks from the  
20 hygienic standpoint, since the tab, by opening toward the inside of the can, dips into the drink both during opening and during consumption of the drink.

In order to overcome this drawback, it has been proposed to apply to the lid a protection made of plastic or aluminum (optionally coupled  
25 aluminum), which must be removed before opening the can.

This solution, in addition to being expensive to provide, has complications in relation to disposal, since the covering must be stored in waste containers that are different from those for cans, where sorted waste collection is provided.

30 Another drawback of the system described above is that the can, after

opening, can no longer be closed again, with complications in relation to difficulties in transport, the risk of contamination and/or degradation of the product by loss of aroma and loss of its organoleptic characteristics.

Accordingly, the entire product is often consumed grudgingly at once,  
5 or consumed only partially and then thrown away together with the can, with waste and further problems in relation to differentiated waste disposal.

A further drawback of traditional cans, when they contain carbonated beverages, is that their exposure to heat sources and/or shaking can cause, upon opening, an uncontrolled outflow of liquid due to overpressure, with  
10 spraying, foaming and consequent soiling of the user.

Therefore, the aim of the present invention is to provide a beverage can provided within an opening mechanism that overcomes the hygienic shortcomings described above of known cans, can be closed, is fully recyclable and practical to dispose, and prevents the uncontrolled outflow of  
15 the product upon opening.

This aim and other objects as will become better apparent from the continuation of the description are achieved by the beverage can having the characteristics described in claim 1, while the dependent claims define other advantageous albeit secondary characteristics of the invention.

20 The invention is now described in greater detail with reference to a preferred but not exclusive embodiment thereof, illustrated by way of nonlimiting example in the accompanying drawings, wherein:

Figure 1 is a perspective view of a can according to the invention in a first operating configuration;

25 Figure 2 is a view, similar to Figure 1, showing the can in a second operating configuration;

Figure 3 is a plan view of the can of Figure 1;

Figure 4 is a plan view of the can of Figure 2;

Figure 5 is an axial sectional view of an upper portion of the can of  
30 Figure 1;

Figures 6 and 7 are two views, similar to Figure 5, of the can in respective two subsequent opening steps;

Figure 7 is a view, similar to Figure 5, showing the can in a first opening step;

5 Figure 8 is an enlarged-scale view of a detail of Figure 5;

Figure 9 is an enlarged-scale view of a detail of Figure 6;

Figures 10 and 11 are two views, similar to Figures 1 and 2, of a can according to an alternative embodiment of the invention.

With reference to the figures, a beverage can 10 comprises a  
10 container provided with a cylindrical wall 12 made of thin sheet metal, for example aluminum, which is closed hermetically at its opposite ends by a bottom 14 and by a lid 16, which are made of the same material.

In a per se conventional manner, the cylindrical wall 12 and the bottom 14 can be formed monolithically by drawing, while the lid 16 is  
15 applied separately in a nonremovable manner by seaming along its edge 16a.

The lid 16 is provided with an opening mechanism 18 of the lever type.

The can 10, except for the opening mechanism 18, can be of a  
20 conventional type and therefore its description is not provided in detail herein.

The opening mechanism 18 comprises an incision 20 with a closed profile which is provided on the lid 16 and forms internally a tab 22, and a lever 24, which cooperates with the tab 22 for the separation of the latter  
25 from the lid 16.

The incision 20 is advantageously provided with a bean-shaped profile and can be laser-cut in a per se conventional manner.

The lever 24 is coupled at an intermediate point to a pin 26 which rises monolithically from the center of the lid 16. The lever 24 has a pushing  
30 end 24a which is arranged proximate to the concave region of the bean-

shaped profile of the incision 20 and an opposite annular grip end 24b.

According to the invention, a screen 28 made of thin flexible material is interposed between the lid 16 and the pushing end 24a of the lever 24 and is fixed to the tab 22 preferably by means of a welding spot W, and can  
5 move between a first position, in which it covers the incision 20, and a second position, in which it exposes the incision 20.

In this embodiment, the screen 28 is supported so that it can rotate about the axis of the cylindrical wall 12 and more particularly is pivoted to the pin 26.

10 The screen 28 can be made of thin sheet metal, preferably of the same material as the can, for ease in disposal.

The screen 28 has an upper wall 28a with a substantially semicircular profile and a side wall 28b which covers the edge 16a of the lid and extends downward from the perimeter of the upper wall 28a so to cover an end  
15 portion of the cylindrical wall 12 over an angle of 180°.

The lower surface of the upper wall 28a of the screen 28, i.e., the surface that faces the lid 16, is provided with a wedge-shaped protrusion 30 which is superimposed on the incision 20 (Figures 5 and 8).

In this exemplary embodiment, the wedge-shaped protrusion 30  
20 advantageously has a closed profile which matches with the profile of the incision 20. As an alternative, the wedge-shaped protrusion 30 might have a profile that matches only with a portion of the profile of the incision 20.

With particular reference to Figures 8 and 9, the wedge-shaped protrusion 30 advantageously has an asymmetric sectional profile, with an  
25 inner side that is substantially perpendicular to the lid 16 and an oblique outer side.

Furthermore, the wedge-shaped protrusion 30 is preferably covered externally by a gasket 32 made of food-compatible plastic material.

Advantageously, the tab 22 has a stiffening ridge 33 which is  
30 extended proximate to the incision 20.

The lower edge 28c and the opposite longitudinal edges 28d of the screen 28 are advantageously rounded for scratch prevention.

To open the can 10, which is initially in the configuration of Figures 1, 3 and 5, the user lifts the grip end 24b of the lever 24. In this manner, the lever 24 presses on the screen 28, at the wedge-shaped protrusion 30, with the opposite pusher end 24a, with an action that is similar to a first-class lever. Accordingly, the wedge-shaped protrusion 30 presses on the lid 16 at the incision 20, generating a fissure which propagates along the entire length of the incision 20, so as to fully separate the tab 22 from the lid 16, as shown in Figures 6 and 9.

At this point, the user rotates the screen 28 through 180° about the pin 26, as shown in Figures 2, 4 and 7. In rotation, the screen 28 carries with it the tab 22, which is welded thereto, thus exposing the opening 0 through which the product can be consumed.

Of course, depending on the shape of the lid 28, a rotation of less than 180° might be sufficient to expose the opening 0.

If the user, after consuming part of the product, wishes to close the can again, he rotates the screen through 180° back to the initial position. The tab 22 is superimposed on the opening 0, with the gasket 32 engaging the edge of the opening 0, sealing it.

In order to facilitate the user in correctly positioning the screen 28 in its two operating configurations, a raised portion (not shown) can be provided on the screen 28 which is adapted to engage alternately one of two recesses (not shown) provided in diametrically opposite positions on the cylindrical wall 12 or on the lid 16 of the can, or other equivalent solutions.

It has been demonstrated that the can according to the invention fully achieves the intended aim and objects.

During opening and during consumption of the beverage, the outer surface of the tab 22 never makes contact with the product, with evident advantages from the hygienic standpoint.

Furthermore, the screen 28 protects the lid 16 against contaminations in the region of the opening 0, whether the user rests his lips, with further advantages in terms of hygiene.

The possibility to close the can again allows to avoid waste, facilitates transport, and eliminates the risks of contamination and degradation of the product.

Furthermore, the can is fully recyclable and practical to dispose, since it can be made entirely of the same metallic material.

The screen 28 has the additional advantage of protecting the user against uncontrolled outflows of the product upon opening.

Figures 10 and 11 are views of an alternative embodiment of the invention, in which the elements that correspond to the preceding embodiment are identified by the same reference number increased by 100.

This alternative embodiment differs from the preceding one merely in that the screen 128, instead of being extended over an angle of  $180^\circ$ , is extended over a broader angle for greater protection.

Some preferred embodiments of the invention have been described, but of course the person skilled in the art may provide different modifications and variations within the scope of the claims.

For example, the screen may be provided with dimensions that are slightly larger than the can and with a cambered profile so that the wedge-shaped protrusion, after first opening, applies a slight pressure to the edge of the opening 0 so as to optimize closure.

Furthermore, the incision that delimits the tab might have a positioning, dimensions and profile which are different from what has been described. For example, it may have a circular, oval, or other arc-shaped or polygonal profile. Furthermore, the incision might be provided on the internal surface of the lid or two mutually opposite incisions might be provided on respective opposite faces of the lid.

Likewise, the lever may have a shape and dimensions that are

different from the ones described and illustrated, for example, it may have a profile shaped like a ring, an oval or a droplet.

Depending on the materials and the thicknesses used, the lever might even not be necessary and the can might be opened simply by pressing with  
5 the thumb on the tab.

The side wall of the screen might have a height that is different from what is shown, for example it might cover only the edge of the can or, depending on the circumstances, might even be absent.

Of course, although in the present description and in the claims  
10 reference is always made to beverages for the sake of simplicity in description, the opening system described herein and the corresponding can can be applied generically to any liquid.

The invention, thus conceived, is susceptible of numerous modifications and variations, all of which are within the scope of the  
15 appended claims. Moreover, all the details may be substituted by other, technically equivalent elements.

In practice the materials employed, provided they are compatible with the specific use, and the contingent dimensions and shapes, may be any according to requirements and to the state of the art.

20 The disclosures in Italian Patent Application No. 102018000003019 from which this application claims priority are incorporated herein by reference.

Where technical features mentioned in any claim are followed by reference signs, those reference signs have been included for the sole  
25 purpose of increasing the intelligibility of the claims and accordingly, such reference signs do not have any limiting effect on the interpretation of each element identified by way of example by such reference signs.

## CLAIMS

1. A beverage can, comprising a cylindrical wall (12) which is closed at the opposite ends by a bottom (14) and by a lid (16) made of thin sheet metal, which is provided with an incision (20) with a closed profile so as to  
5 form internally a tab (22) which can be separated by pressing from the material of said lid (16), characterized in that it comprises a screen (28) made of thin flexible material which is applied to said lid (16), is fixed to said tab (22), and can be moved between a first position, in which it covers said incision (20), and a second position, in which it exposes said incision  
10 (20).

2. The beverage can according to claim 1, characterized in that said screen (28) is supported so that it can rotate about the axis of said cylindrical wall (12).

3. The beverage can according to claim 1 or 2, characterized in that  
15 said screen (28) is pivoted to a pin (26) which rises from the center of the lid (16).

4. The beverage can according to one of claims 1-3, characterized in that said screen (28) is provided with an upper wall (28a) with a profile shaped like a circular sector, and a side wall (28b) which is extended  
20 downward from the perimeter of said upper wall (28a) so as to cover an end portion of the cylindrical wall (12).

5. The beverage can according to one of claims 1-4, characterized in that a surface of said screen (28) which faces said lid (16) has a wedge-shaped protrusion (30) which is superimposed on said incision (20).

25 6. The beverage can according to claim 5, characterized in that said wedge-shaped protrusion (30) has a profile which matches with at least one portion of the profile of the incision (20).

7. The beverage can according to claim 6, characterized in that said wedge-shaped protrusion (30) has an asymmetric sectional profile, with an  
30 inner side which is substantially perpendicular to the lid (16) and an oblique

outer side.

8. The beverage can according to claim 6 or 7, characterized in that said wedge-shaped protrusion (30) is covered externally by a gasket (32).

5 9. The beverage can according to one of claims 2-8, characterized in that said screen (28) has at least one protrusion which is adapted to engage alternately one of two recesses provided in said cylindrical wall (12) or on said lid (16) when the screen (28) is rotated between said first position and said second position.

10 10. The beverage can according to one of claims 1-9, characterized in that said screen (28) is made of thin sheet metal.

11. The beverage can according to one of claims 1-10, characterized in that it comprises a lever (24) which is superimposed on said lid (16) and is provided with a pushing end (24a) which cooperates with said tab (22) for the separation of the latter from the lid (16).

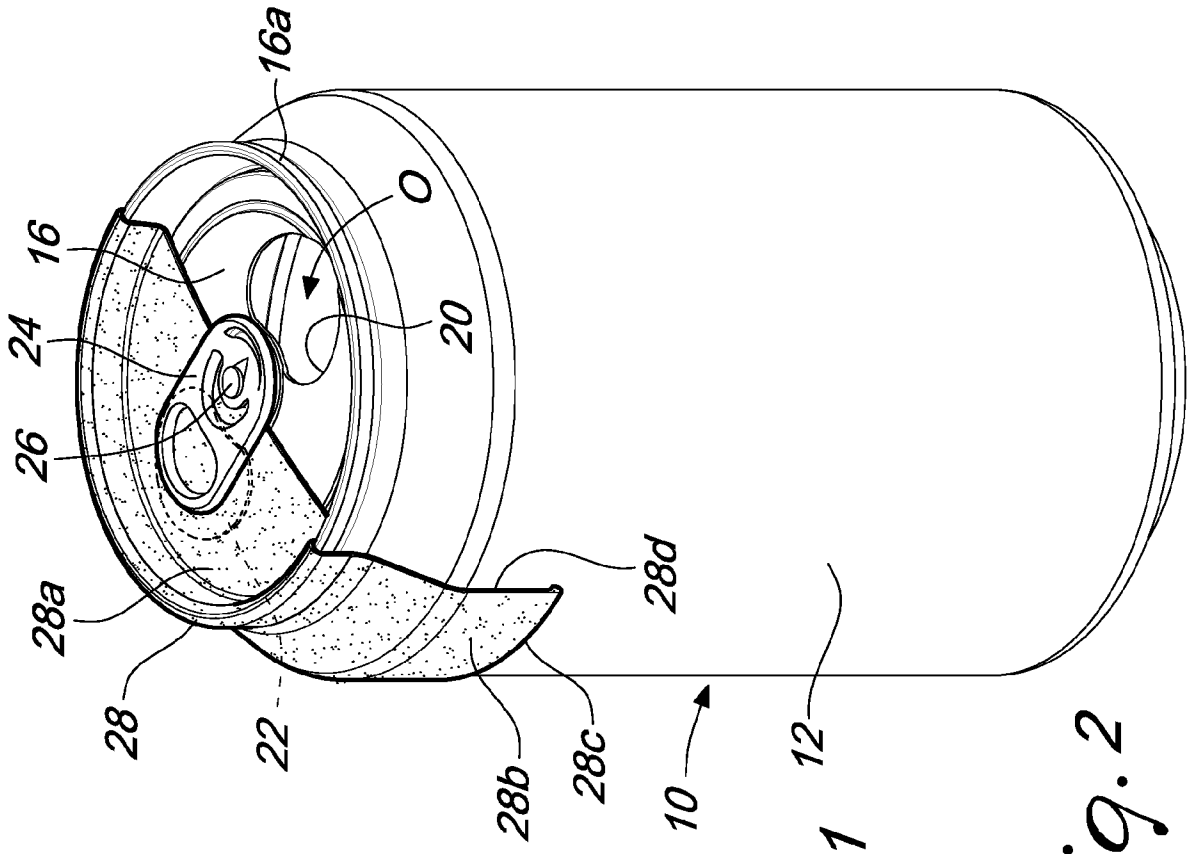

Fig. 1

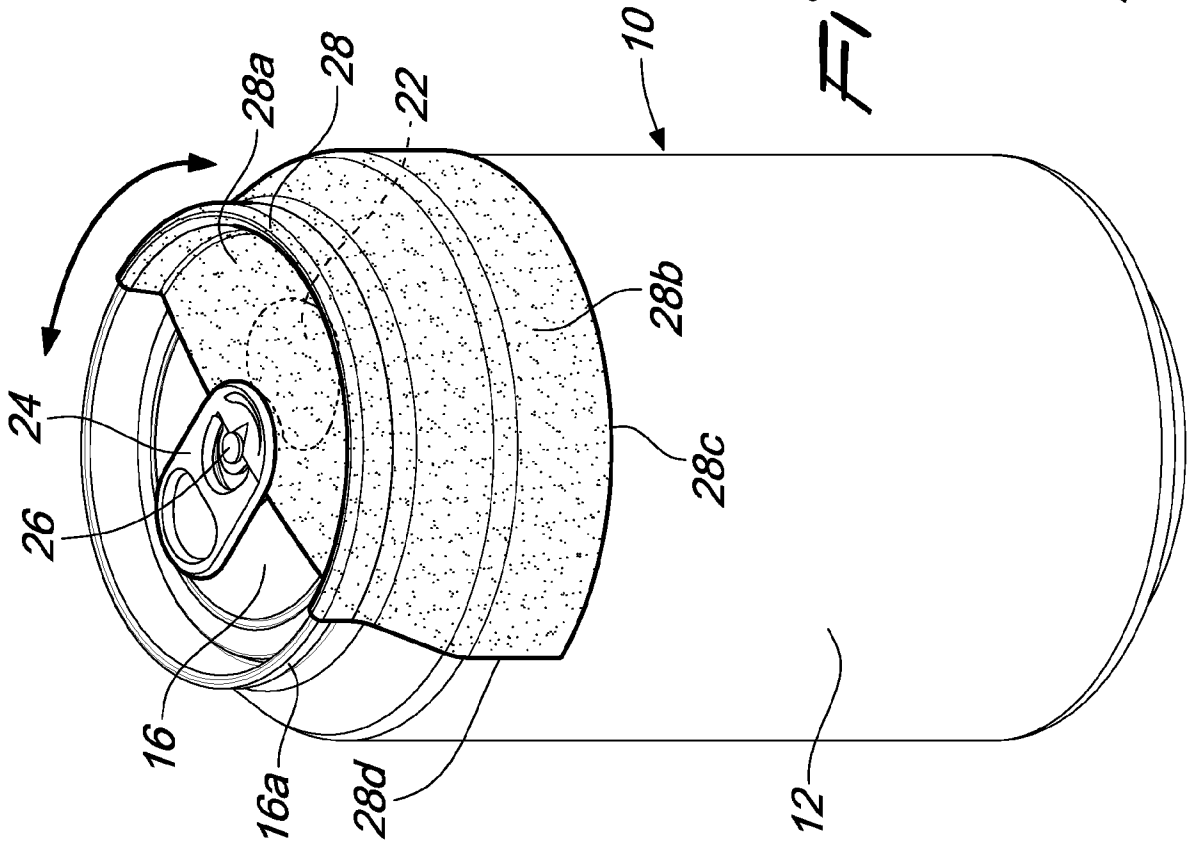
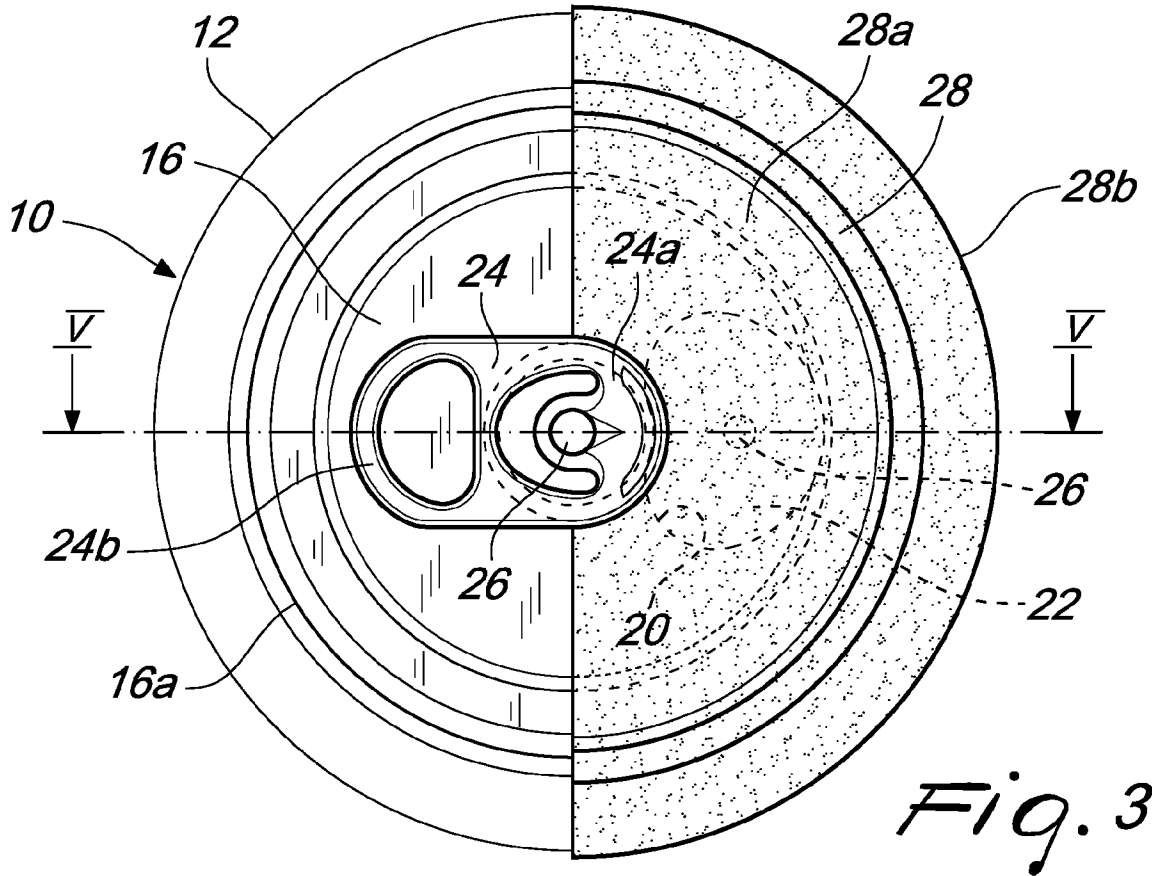
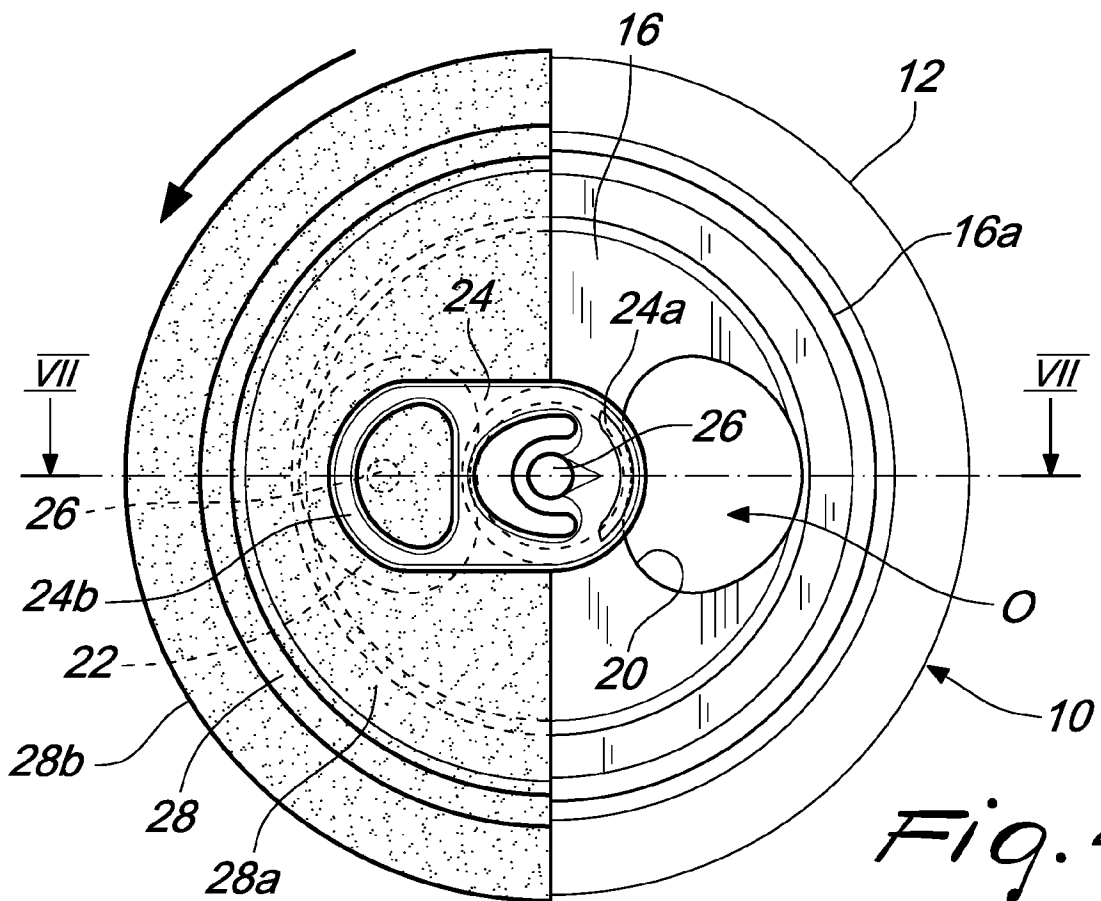

Fig. 2



*Fig. 3*



*Fig. 4*

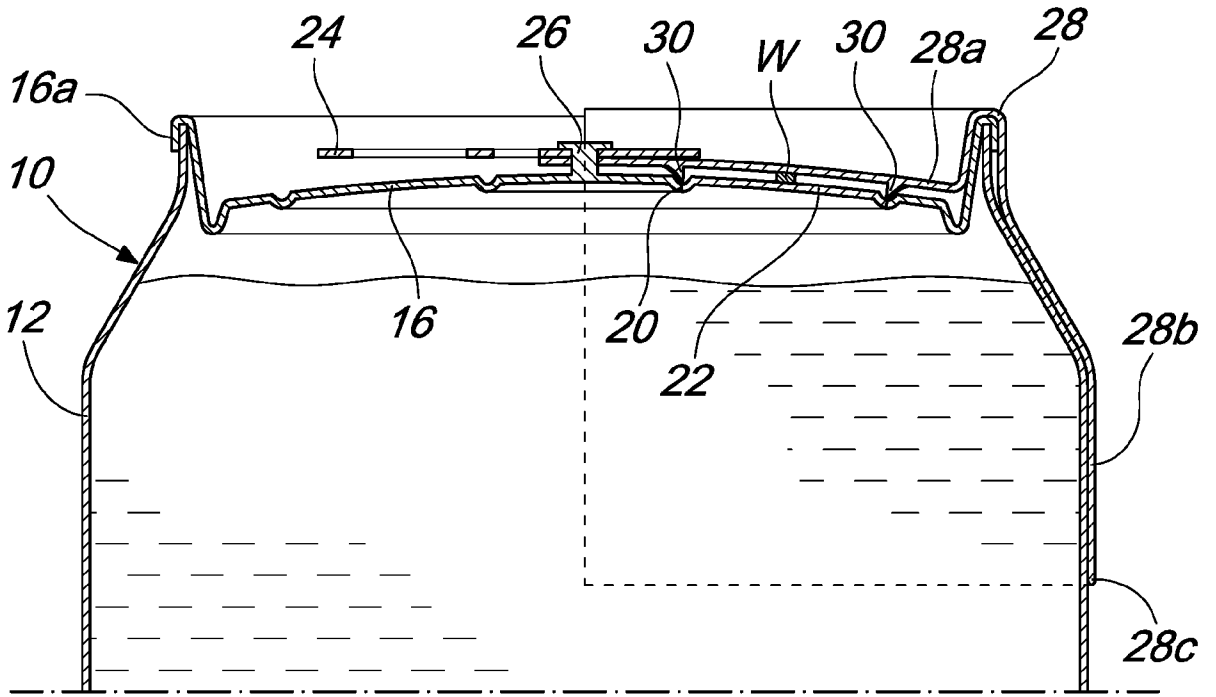

*Fig. 5*

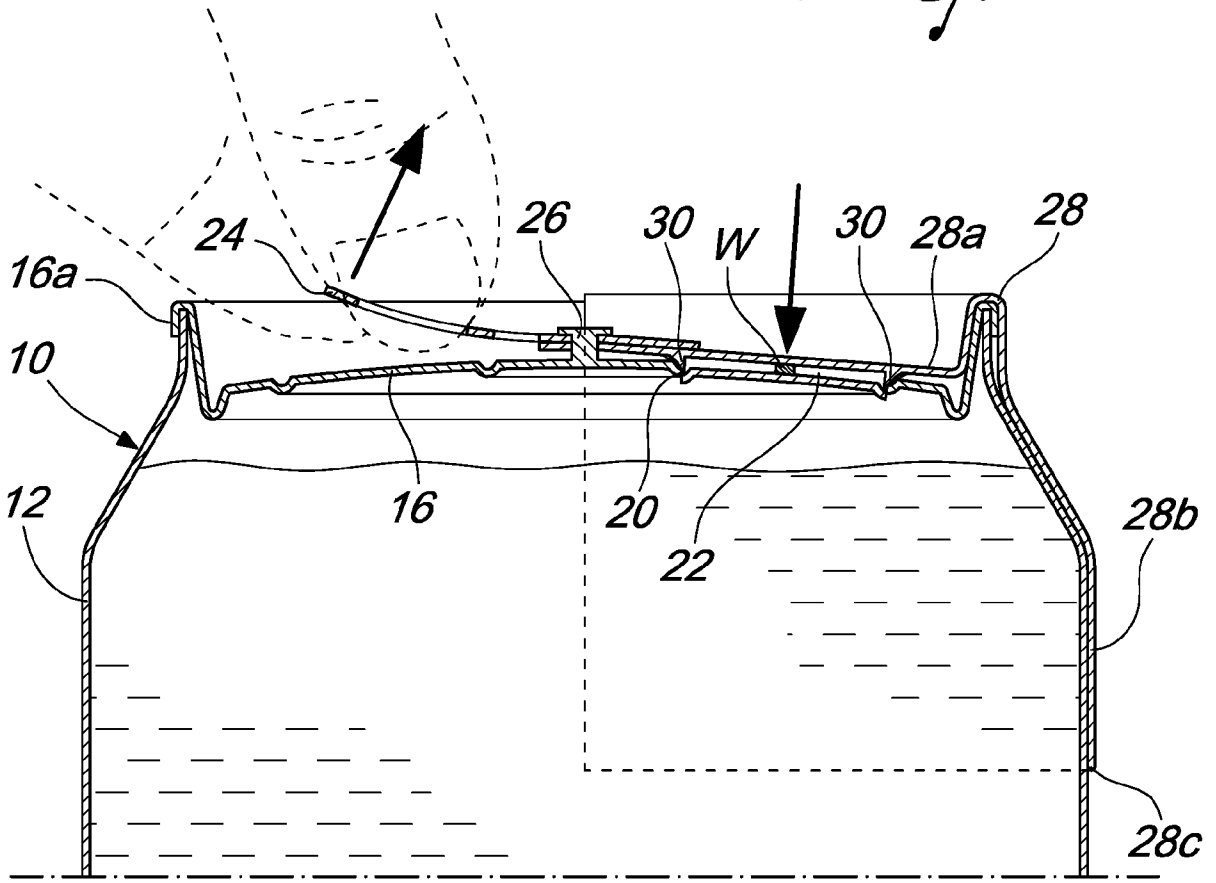

*Fig. 6*

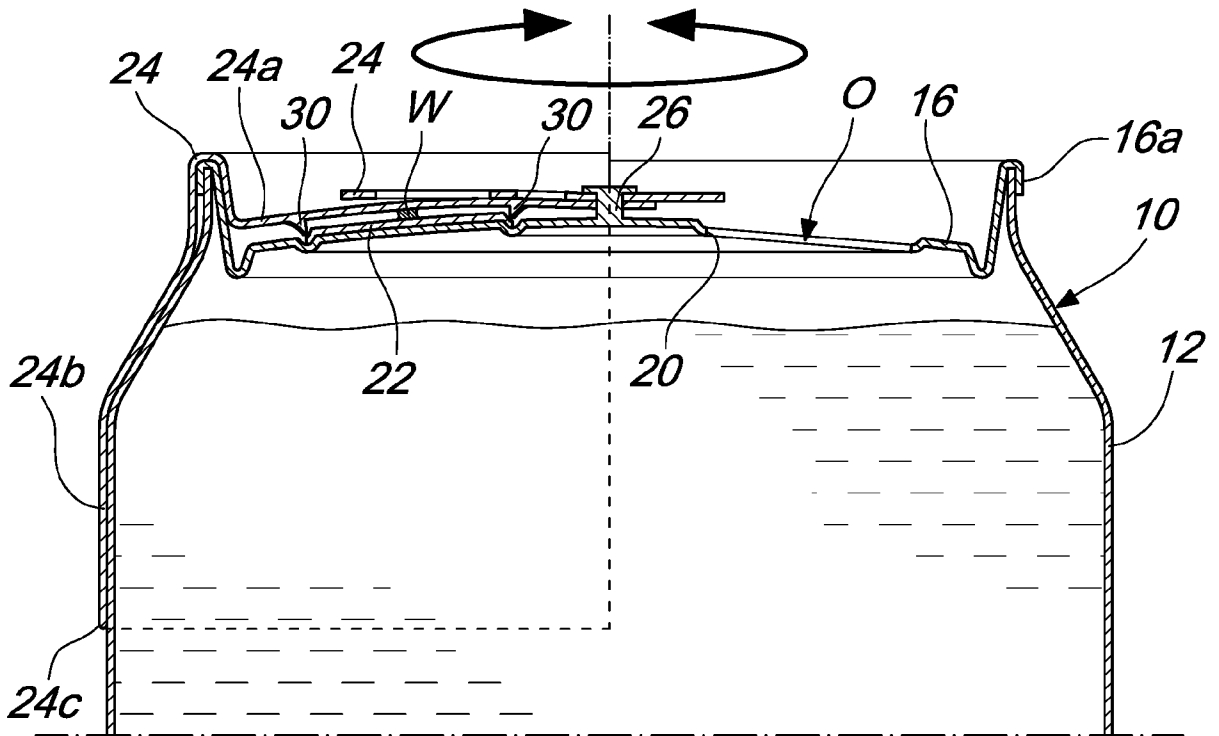

*Fig. 7*

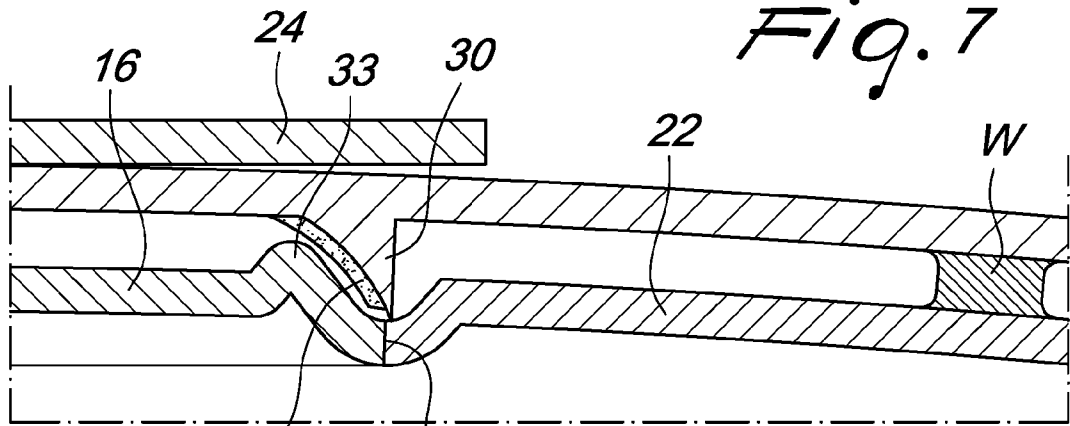

*Fig. 8*

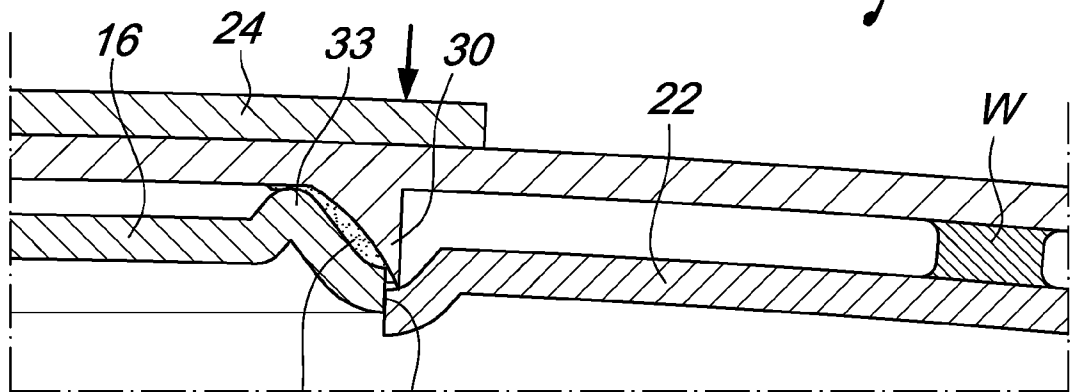

*Fig. 9*

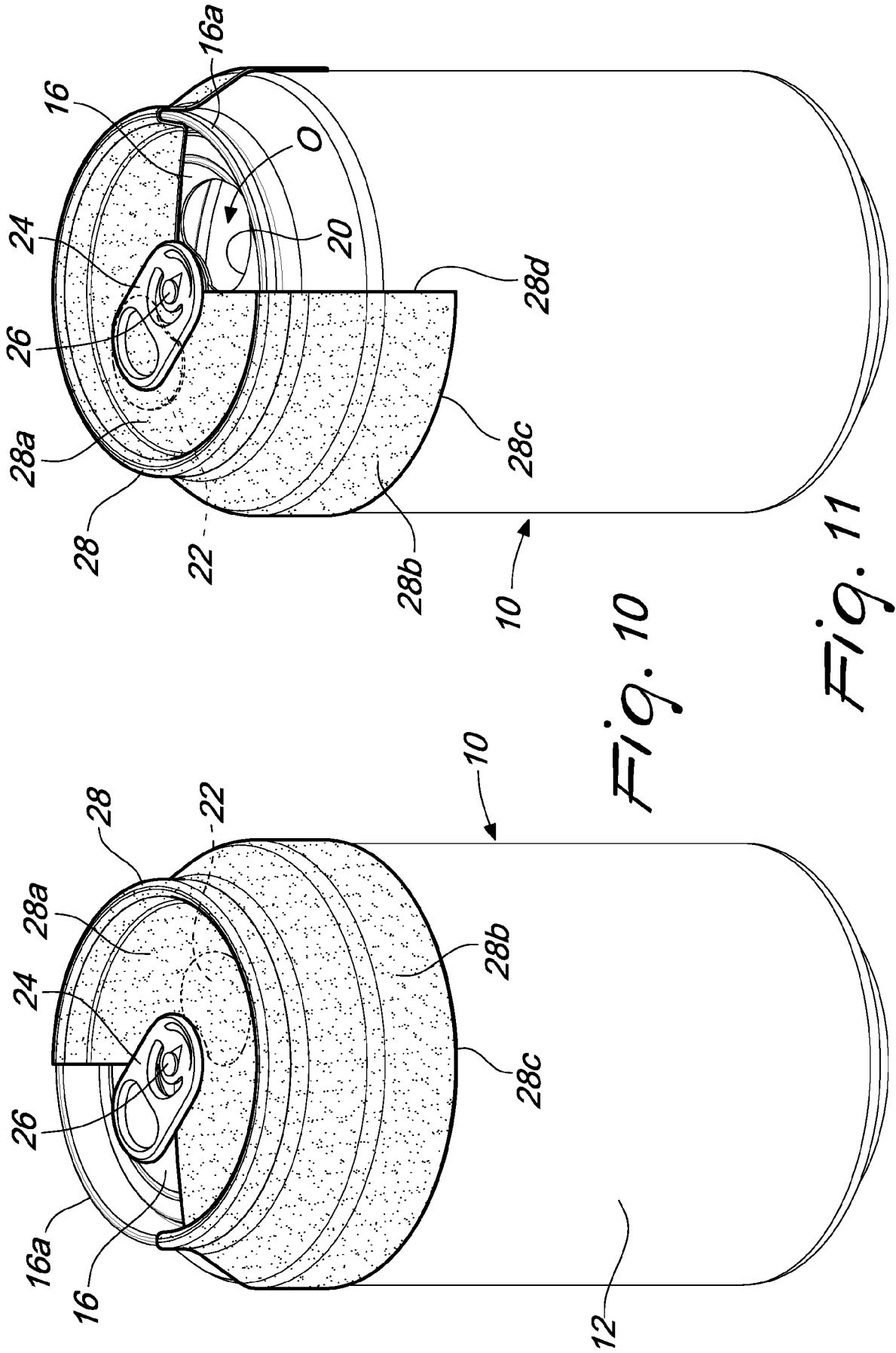

Fig. 10

Fig. 11

**INTERNATIONAL SEARCH REPORT**

International application No  
PCT/EP2019/054439

**A. CLASSIFICATION OF SUBJECT MATTER**  
INV. B65D17/28  
ADD.  
  
According to International Patent Classification (IPC) or to both national classification and IPC

**B. FIELDS SEARCHED**  
Minimum documentation searched (classification system followed by classification symbols)  
B65D

Documentation searched other than minimum documentation to the extent that such documents are included in the fields searched

Electronic data base consulted during the international search (name of data base and, where practicable, search terms used)  
EPO-Internal, WPI Data

**C. DOCUMENTS CONSIDERED TO BE RELEVANT**

Category*	Citation of document, with indication, where appropriate, of the relevant passages	Relevant to claim No.
X	WO 97/10150 A1 (MONGARLI CESARE [IT]; MONGARLI ALESSANDRO [IT]) 20 March 1997 (1997-03-20)	1,10
A	page 1, last paragraph page 4, paragraph 3; figures 1-10	2-9,11
A	----- US 2009/032531 A1 (NAVARE RAVI Y [US] ET AL) 5 February 2009 (2009-02-05) abstract; figures 1-5	1,2,4
A	----- WO 2009/001984 A1 (CHOI YOUN-SEOK [KR]) 31 December 2008 (2008-12-31) paragraph [0033] - paragraph [0046]; figures 2-4	1-4
A	----- US 5 813 559 A (CHO SUNG HO [KR]) 29 September 1998 (1998-09-29) the whole document	1-4
	-----	

Further documents are listed in the continuation of Box C.

See patent family annex.

\* Special categories of cited documents :

- "A" document defining the general state of the art which is not considered to be of particular relevance
- "E" earlier application or patent but published on or after the international filing date
- "L" document which may throw doubts on priority claim(s) or which is cited to establish the publication date of another citation or other special reason (as specified)
- "O" document referring to an oral disclosure, use, exhibition or other means
- "P" document published prior to the international filing date but later than the priority date claimed

- "T" later document published after the international filing date or priority date and not in conflict with the application but cited to understand the principle or theory underlying the invention
- "X" document of particular relevance; the claimed invention cannot be considered novel or cannot be considered to involve an inventive step when the document is taken alone
- "Y" document of particular relevance; the claimed invention cannot be considered to involve an inventive step when the document is combined with one or more other such documents, such combination being obvious to a person skilled in the art
- "&" document member of the same patent family

Date of the actual completion of the international search  
  
9 May 2019

Date of mailing of the international search report  
  
20/05/2019

Name and mailing address of the ISA/  
European Patent Office, P.B. 5818 Patentlaan 2  
NL - 2280 HV Rijswijk  
Tel. (+31-70) 340-2040,  
Fax: (+31-70) 340-3016

Authorized officer  
  
Mans-Kamerbeek, M

# INTERNATIONAL SEARCH REPORT

Information on patent family members

International application No

PCT/EP2019/054439

Patent document cited in search report	Publication date	Patent family member(s)	Publication date
WO 9710150	A1	20-03-1997	
		AT 188432 T	15-01-2000
		AU 704324 B2	22-04-1999
		BG 62765 B1	31-07-2000
		BR 9610499 A	21-12-1999
		CA 2231679 A1	20-03-1997
		CN 1200704 A	02-12-1998
		CZ 289442 B6	16-01-2002
		DE 69606050 D1	10-02-2000
		DE 69606050 T2	14-09-2000
		DK 0850174 T3	26-06-2000
		EA 199800291 A1	25-02-1999
		EE 9800067 A	17-08-1998
		EP 0850174 A1	01-07-1998
		EP 0947435 A1	06-10-1999
		ES 2143223 T3	01-05-2000
		GE P20032919 B	10-07-2002
		GR 3033096 T3	31-08-2000
		HK 1018038 A1	16-11-2001
		HU 9901409 A2	30-08-1999
		IT T0950725 A1	11-03-1997
		JP H11512370 A	26-10-1999
		KR 19990044559 A	25-06-1999
		NO 317499 B1	08-11-2004
		NZ 318406 A	28-01-2000
		PL 325461 A1	20-07-1998
		PT 850174 E	30-06-2000
		RO 116472 B1	28-02-2001
		SK 31298 A3	09-09-1998
		TR 199800435 T1	22-06-1998
		US 6062414 A	16-05-2000
		WO 9710150 A1	20-03-1997
-----			
US 2009032531	A1	05-02-2009	NONE
-----			
WO 2009001984	A1	31-12-2008	
		KR 20090025208 A	10-03-2009
		WO 2009001984 A1	31-12-2008
-----			
US 5813559	A	29-09-1998	
		JP H101137 A	06-01-1998
		JP 2913278 B2	28-06-1999
		KR 0141618 B1	15-07-1998
		US 5813559 A	29-09-1998
-----			