

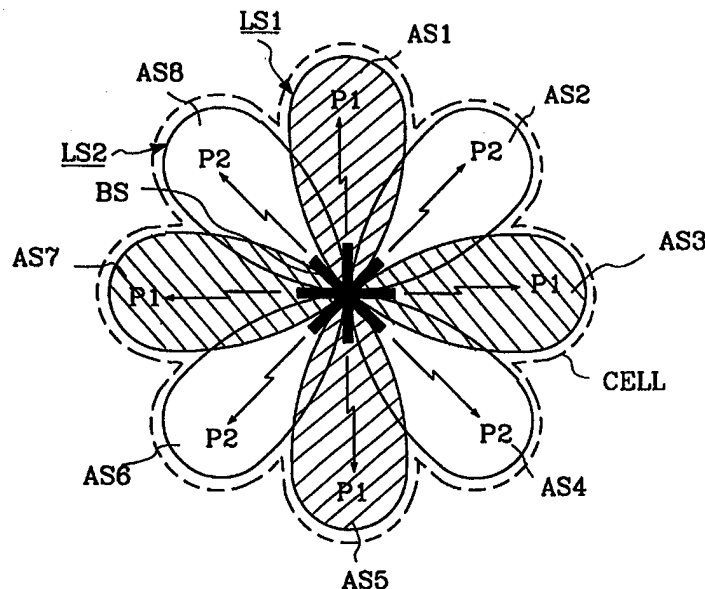

## INTERNATIONAL APPLICATION PUBLISHED UNDER THE PATENT COOPERATION TREATY (PCT)

<p>(51) International Patent Classification <sup>6</sup> : <b>H04Q 7/36</b></p>	<p><b>A1</b></p>	<p>(11) International Publication Number: <b>WO 98/59512</b></p> <p>(43) International Publication Date: 30 December 1998 (30.12.98)</p>
<p>(21) International Application Number: PCT/SE98/00993</p> <p>(22) International Filing Date: 26 May 1998 (26.05.98)</p> <p>(30) Priority Data: 9702408-7 24 June 1997 (24.06.97) SE</p> <p>(71) Applicant: TELEFONAKTIEBOLAGET LM ERICSSON [SE/SE]; S-126 25 Stockholm (SE).</p> <p>(72) Inventors: KARLSSON, Jonas; Marine City Kanazawa-bunko B-1305, 391, Shiba-machi, Kanazawa-ku, Yokohama 236-0012 (JP). LUNDSJÖ, Johan; Tranebergsvägen 93, S-167 45 Bromma (SE). OVESJÖ, Fredrik; Ankdammsgatan 36, 11trp, S-171 67 Solna (SE).</p> <p>(74) Agent: ERICSSON RADIO SYSTEMS AB; Common Patent Dept., S-164 80 Stockholm (SE).</p>		<p>(81) Designated States: AL, AM, AT, AU, AZ, BA, BB, BG, BR, BY, CA, CH, CN, CU, CZ, DE, DK, EE, ES, FI, GB, GE, GH, GM, GW, HU, ID, IL, IS, JP, KE, KG, KP, KR, KZ, LC, LK, LR, LS, LT, LU, LV, MD, MG, MK, MN, MW, MX, NO, NZ, PL, PT, RO, RU, SD, SE, SG, SI, SK, SL, TJ, TM, TR, TT, UA, UG, UZ, VN, YU, ZW, ARIPO patent (GH, GM, KE, LS, MW, SD, SZ, UG, ZW), Eurasian patent (AM, AZ, BY, KG, KZ, MD, RU, TJ, TM), European patent (AT, BE, CH, CY, DE, DK, ES, FI, FR, GB, GR, IE, IT, LU, MC, NL, PT, SE), OAPI patent (BF, BJ, CF, CG, CI, CM, GA, GN, ML, MR, NE, SN, TD, TG).</p> <p><b>Published</b> <i>With international search report.</i></p>

(54) Title: SECTORIZATION OF CELLULAR CDMA-SYSTEM



(57) Abstract

The present invention relates to sectorization of a cellular CDMA-system. Each sectorized cell (CELL) in the CDMA-system comprises a number of antenna sectors (AS1-AS8) having overlapping regions. Each cell is allocated a number of at least two different pilot channels (P1, P2). Two antenna sectors having a common overlapping region are not allowed to use the same pilot channel. At least one of said pilot channels (P1, P2) are reused within the cell, by at least two antenna sectors with no common overlapping region. The antenna sectors that use the same pilot signal are constituting a logical sector (LS1, LS2). A mobile station can communicate with the base station in a cell by using one or more antenna sectors within one or more logical sectors. If a mobile station communicates with the base station within a number of antenna sectors within the same logical sector, no softer handoff is required between the antenna sectors.

**FOR THE PURPOSES OF INFORMATION ONLY**

Codes used to identify States party to the PCT on the front pages of pamphlets publishing international applications under the PCT.

AL	Albania	ES	Spain	LS	Lesotho	SI	Slovenia
AM	Armenia	FI	Finland	LT	Lithuania	SK	Slovakia
AT	Austria	FR	France	LU	Luxembourg	SN	Senegal
AU	Australia	GA	Gabon	LV	Latvia	SZ	Swaziland
AZ	Azerbaijan	GB	United Kingdom	MC	Monaco	TD	Chad
BA	Bosnia and Herzegovina	GE	Georgia	MD	Republic of Moldova	TG	Togo
BB	Barbados	GH	Ghana	MG	Madagascar	TJ	Tajikistan
BE	Belgium	GN	Guinea	MK	The former Yugoslav Republic of Macedonia	TM	Turkmenistan
BF	Burkina Faso	GR	Greece			TR	Turkey
BG	Bulgaria	HU	Hungary	ML	Mali	TT	Trinidad and Tobago
BJ	Benin	IE	Ireland	MN	Mongolia	UA	Ukraine
BR	Brazil	IL	Israel	MR	Mauritania	UG	Uganda
BY	Belarus	IS	Iceland	MW	Malawi	US	United States of America
CA	Canada	IT	Italy	MX	Mexico	UZ	Uzbekistan
CF	Central African Republic	JP	Japan	NE	Niger	VN	Viet Nam
CG	Congo	KE	Kenya	NL	Netherlands	YU	Yugoslavia
CH	Switzerland	KG	Kyrgyzstan	NO	Norway	ZW	Zimbabwe
CI	Côte d'Ivoire	KP	Democratic People's Republic of Korea	NZ	New Zealand		
CM	Cameroon			PL	Poland		
CN	China	KR	Republic of Korea	PT	Portugal		
CU	Cuba	KZ	Kazakstan	RO	Romania		
CZ	Czech Republic	LC	Saint Lucia	RU	Russian Federation		
DE	Germany	LI	Liechtenstein	SD	Sudan		
DK	Denmark	LK	Sri Lanka	SE	Sweden		
EE	Estonia	LR	Liberia	SG	Singapore		

## SECTORIZATION OF CELLULAR CDMA-SYSTEM

**FIELD OF THE INVENTION**

The present invention relates to a cellular sectorized CDMA-system and a method in said cellular sectorized CDMA-system.

5 More particularly the present invention relates to a cellular CDMA-system and a method in said system wherein each cell is covered by a number of antenna sectors and wherein each cell uses a number of different pilot channels.

**BACKGROUND OF THE INVENTION**

10 In a CDMA-system all users transmit signals by using the same frequency band simultaneously. Each connection between a primary station and a secondary station in the system uses channels for communication, which channels are defined by separate spreading codes. The primary station can be a base station and the  
15 secondary station can be a mobile station. Some information has to reach all mobile stations in a cell. In CDMA-systems according to the IS95-standard a special control channel, the pilot channel, is listened to by all mobile stations within a cell. The pilot channel has a specific spreading code and  
20 utilizes the same frequency band as traffic channels. Each cell in the system transmits a pilot channel and the pilot channels in all cells use the same code with different spread spectrum code phase offsets, which allow them to be distinguished.

The pilot channel is used to give the mobile station initial  
25 system synchronization. After synchronization the pilot channel is used by the mobile station as a coherent carrier phase reference for demodulation of the other signals from this base station. It is also used in power measurements performed by the mobile station, that indicate the need for handoff. Coherent

demodulation of received signals is performed by the mobile stations in the downlink. This is accomplished by using the pilot channel transmitted by the base station to estimate the channel characteristics. The channel estimation is then supposed  
5 to correspond to the channel characteristics of the traffic channels in the cell. It is therefore essential that the traffic channels and the pilot channel have the same channel characteristics.

To increase the capacity and decrease the interference in a  
10 CDMA-system each cell can be sectorized. Each cell is then covered by a number of directional antenna beams. The area covered by one antenna beam is hereinafter referred to as an antenna sector. The sectorization can be achieved by using antenna arrays or sector antennae creating a number of fixed or  
15 non fixed antenna beams.

The antenna sectors in one cell have overlapping regions. A mobile station communicates with the base station using one or more narrow antenna beams, i.e. antenna sectors. The interference in the system thus decreases because each mobile  
20 station only interferes within a part of a cell.

On the other hand a large number of antenna sectors leads to an increasing number of handoffs between antenna sectors, so called softer handoff. In softer handoff situations a mobile station is connected both to the antenna sector that it is going to leave  
25 as well as the antenna sector that it is going to use in the future. A large number of softer handoffs will therefore lead to decreasing capacity as two antenna sectors are used simultaneously while performing the softer handoff.

The traffic channels can be transmitted in narrow antenna sectors. The pilot channels should preferably be transmitted in the same antenna sectors as the traffic channels in order to perform coherent demodulation of signals received in the mobile stations. It is however not possible to transmit the same pilot channel in antenna sectors that overlap because the channel characteristics of the pilot channel and the traffic channels would differ significantly in the overlapping regions. This would decrease the performance of the coherent demodulation in the mobile stations.

According to the IS95-standard sectorization of cells is possible. All antenna sectors then use different pilot channels, that is different phase offsets in the PN-sequence used for pilot channels. If the system was to be highly sectorized and different pilot channels were to be used in all antenna sectors the number of pilot channels desired in each cell would increase. As all pilot channels use the same code and different offsets the number of different pilot channels is limited.

A disadvantage with a highly sectorized CDMA-system where each antenna sector were to use its own pilot channel is that the pilot channels should have to be reused more often in different cells in the radio communications system. Lowering the reuse distance would degrade the channel estimate.

In the published patent application WO 96/37969 a method of transmitting a pilot channel in a CDMA-system is described. The base station transmits the pilot channel to the mobile stations by using radiation patterns that change in time, that is in a rather narrow antenna beam that change direction in time. The changing antenna beam is controlled so that it reaches all parts of the cell. The pilot channel can also be transmitted

simultaneously in a number of changing antenna beams that are directed not to overlap each other. The base station inform each mobile station of the time when the pilot channel is located in the respective parts of the cell.

5 A disadvantage with this method is that the pilot channel is not continuously transmitted in the whole cell coverage area. The mobile stations have to be informed of when the pilot channel is transmitted in different regions which leads to more signaling. Another disadvantage is that the method cannot be  
10 implemented in IS95-systems.

In the published patent application WO 96/37969 another method of transmitting a pilot channel in a CDMA-system is described. Two different pilot channels containing different information are transmitted. A first pilot channel is transmitted with a  
15 predetermined radiation pattern, for instance an omnidirectional radiation pattern, that decides the coverage of the cell. Alternatively the first pilot channel is transmitted in a narrow antenna lobe that is changing direction in time so that it sweeps all of the cell. A second pilot channel is  
20 transmitted in a narrow antenna lobe that is directed towards a mobile station in the same way as a traffic signal. The first pilot channel is used for detecting a need for a handoff between two base stations. The second pilot channel is transmitted in the same antenna lobe as a traffic signal and  
25 can thus be used as a phase reference for coherent detection of signals in the mobile station.

A disadvantage with this method is that two different pilot channels are used for detecting the need of handoff and for coherent detection in the mobile station. This means that the

method cannot be implemented in systems that follows the IS95-standard and other standards that use one single pilot channel.

#### **SUMMARY OF THE DISCLOSURE**

5 The present invention deals with a problem how to sectorize a cell in a CDMA-system so that the pilot channels can be used both for estimating the channel characteristics of the traffic channels and for deciding when to perform handoff without using different pilot channels in each antenna sector.

10 Another problem is how to communicate with mobile stations within more than one antenna sector without having to perform a lot of softer handoffs.

15 It is an object of the present invention to use the pilot channel in a sectorized cellular CDMA-system both for estimating the channel characteristics of the traffic channels and for deciding when to perform handoff without using different pilot channels in each antenna sector.

20 The problems are solved by the invention by using different pilot channels in antenna sectors that have a common overlapping region, but using at least one of said pilot channels in more than one antenna sector. Thus the number of different pilot channels within one cell is less than the number of antenna sectors within the cell. Communication between a primary station and a secondary station is performed within one or more antenna sectors.

25 In more detail the problems are solved by allocating at least two different pilot channels to a sectorized cell. Different pilot channels are then transmitted in antenna sectors that have a common overlapping region. At least one of the pilot

channels are used in at least two antenna sectors with essentially no common overlapping region. Antenna sectors with the same pilot channel are forming a logical sector.

5 A secondary station, or mobile station, communicates in uplink and in downlink with a primary station, or a base station, in the cell within at least one logical sector that is active. The decision whether a logical sector is active or not is based on measured uplink and downlink signal quality parameters.

10 In the uplink communication, signals from the mobile station are received from the antenna sectors within each active logical sector. A signal quality parameter are measured for each received signal and at least one antenna sector within each active logical sector is selected for communication. If more than one antenna sector within each logical sector are  
15 chosen, the signals from these selected antenna sectors are combined.

If more than one logical sector is active the combined signals from each active logical sector are softer handoff combined. The resulting signal is decoded.

20 In the downlink communication a signal is generated. If more than one logical sector is active the generated signal is softer handoff distributed to each active logical sector. At least one antenna sector within each active logical sector is selected for communication in dependence of the signal quality  
25 parameter that was measured in the uplink. The signal is transmitted simultaneously in the selected antenna sectors within each active logical sector.



An advantage with the invention is that a cell can be sectorized without using as many different pilot channels as the number of antenna sectors.

Another advantage is that a mobile station can communicate with  
5 a base station within more than one antenna sector belonging to the same logical sector without signaling for softer handoff. As a consequence a cell in a CDMA-system can be sectorized without increasing the base station complexity regarding softer handoffs.

#### 10 BRIEF DESCRIPTION OF THE DRAWINGS

Figure 1 illustrates a cell divided into eight antenna sectors using the same pilot channel according to an example showing the problem to be solved.

Figure 2 illustrates a cell divided into eight antenna sectors  
15 using different pilot channels in each antenna sector according to prior art.

Figure 3 illustrates a cell divided into eight antenna sectors, using two different pilot channels according to the present invention.

20 In Figure 4 an uplink apparatus according to an embodiment of the invention concerning the uplink situation in a cell is shown.

In Figure 5 a downlink apparatus according to an embodiment of the invention concerning the downlink situation in a cell is  
25 shown.

In Figure 6 a flow diagram of an embodiment of the invention of a method of communication in uplink.

In Figure 7 a flow diagram of an embodiment of the invention of a method of communication in downlink.

#### BRIEF DESCRIPTION OF THE DISCLOSURE

In Figure 1, a sectorized cell with overlapping regions is shown. The cell comprises a base station BS comprising antenna means for generating eight fix antenna lobes each covering one antenna sector AS1-AS8. Neighbouring antenna sectors have overlapping regions R. The system shown in Figure 1 is an example illustrating the problem to be solved by the invention. The same pilot channel P is transmitted in the downlink in all antenna sectors. This would have been a natural way of wanting to implement a sectorized system if the pilot channel was to be used for handoff indication only.

The channel characteristics in the overlapping regions based on measurements on the pilot channel will however differ significantly from the channel characteristics of a traffic channel transmitted in that antenna sector. Since the lobes overlap, the signal transmitted on the pilot channel will be superimposed in the overlapping region resulting in an antenna pattern differing from the antenna pattern of the traffic channels. The performance loss when using the channel estimate on the pilot channel for coherent detection in the downlink would then be severe. It is therefore not possible to transmit the same pilot channel in antenna sectors with overlapping regions.

In Figure 2 a sectorized cell according to prior art is shown. The cell comprises a base station BS comprising antenna means for generating eight fix antenna lobes each covering one antenna sector AS1-AS8. Neighbouring antenna sectors have overlapping

regions. Each antenna sector has its own pilot channel P1-P8. This means that the sector is allocated eight different pilot channels. No sectors with overlapping regions use the same pilot channel which means that the channel estimates are correct in  
5 the cell. However the number of pilot channels within a cell is the same as the number of antenna sectors. A highly sectorized cell thus uses a high number of different pilot channels. The reuse distance between two cells having the same pilot channels thus decreases leading to increased interference in such a  
10 system.

According to the present invention each cell in a cellular CDMA-system is divided into at least four antenna sectors. Each cell comprises one base station and a number of mobile stations. The base station comprises antenna means, for instance antenna  
15 arrays or sector antennae, which generate fix narrow antenna beams each covering one antenna sector of the cell. Each base station in the system is allocated a number of at least two pilot channels.

Two antenna sectors with a common overlapping region are not  
20 allowed to use the same pilot channel. At least one pilot channel is reused in one or more antenna sectors within one cell. The pilot channels can then be transmitted from the same antenna means as the traffic channels, thus having the same antenna pattern and the same channel characteristics. Correct  
25 coherent detection can then be performed in the mobile stations. The union of antenna sectors that use the same pilot channel is referred to as a logical sector.

In Figure 3 a sectorized cell CELL using two different pilot channels P1 and P2 according to one embodiment of the present  
30 invention is shown. In the present example, the cell is

sectorized into eight antenna sectors AS1-AS8. Two adjacent antenna sectors have overlapping regions. In this example it is possible to use only two different pilot channels in the cell and thus use each pilot channel in four non-overlapping antenna sectors. A first pilot channel P1 and a second different pilot channel P2 are therefore allocated to the cell CELL.

Neighbouring antenna sectors thus use different pilot channels. The pilot channels P1 and P2 can be used in more than one antenna sector and in this example every other antenna sector use the same pilot channel. The first pilot channel P1 is thus used in the antenna sectors AS1, AS3, AS5, AS7 and the second pilot channel is used in the antenna sectors AS2, AS4, AS6, AS8. Hence in this example the cell comprises two logical sectors LS1, LS2.

In one embodiment of the present invention a mobile station may only communicate with the base station using one antenna sector. This embodiment ensures that the interference in the downlink in the radio communication system is kept low due to the fact that radio communication with one mobile station is only performed in a narrow antenna sector of a cell. Diversity combining within one antenna sector can be performed but diversity combining of signals within different antenna sectors cannot be performed in such an embodiment.

In another embodiment of the present invention a mobile station may communicate with the base station using more than one antenna sector. If the signal transmitted from the mobile station has been reflected or scattered, several multipath signals including those arriving from different antenna sectors could then be detected by the base station. In such an embodiment, multipath signals from one mobile station arriving

from different antenna sectors can be diversity combined in the base station. In the same way the base station can simultaneously transmit the same signal in more than one antenna sector and due to for instance scattering the signals can be received and diversity combined by one mobile station.

Signal quality measurements are currently performed by the mobile station on the pilot channel in the downlink. The signal quality measurements can for instance be signal strength and/or interference measurements. Based on these measurements one or more logical sectors could be selected as active. Antenna sectors within an active logical sector should then be used for communication with a specific mobile station. If only one logical sector is selected as active, signals from several antenna sectors within this logical sector could be combined without having to perform a softer handoff combination. In such a case the mobile station will not notice that it communicates with more than one antenna sector. Less signaling between the mobile station and the base station is then needed, than in a softer handoff situation.

In Figure 4, one embodiment of an uplink apparatus for receiving uplink signals within one sectorized cell according to the present invention is shown. In the present embodiment the uplink apparatus is supposed to be comprised in the base station of the cell. It is however well understood that some parts of said uplink apparatus can be comprised in for instance a base station controller. The cell is assumed to be sectorized in the same way as was shown in Figure 3 with eight antenna sectors forming two logical sectors. One mobile station is assumed to be situated inside the cell and communicating with the base station. The present uplink apparatus comprises an uplink communication unit

301a, 301b for each logical sector. The apparatus further comprises a control unit 302 that decides which logical sectors that are to be active. In the present example it is assumed that both logical sectors are active.

5 Each uplink communication unit comprises four receivers R1,R3,R5,R7 and R2,R4,R6,R8, each connected to antenna means generating one antenna lobe for each receiver. Each antenna lobe covers one antenna sector. The antenna means could for instance be antenna arrays or sector antennae. The antenna sectors from  
10 the receivers R1, R3, R5, R7 cover a first logical sector and the antenna sectors from the remaining receivers R2, R4, R6, R8 cover a second logical sector. The receivers are numbered according to the numbering in Figure 3.

Each receiver R1-R8 then listens to the communication channel of  
15 the mobile station and receives a signal on that channel. The uplink apparatus further comprises a signal processing unit S1-S8 for each receiver. These units comprise for example means for downconverting each received signal to the baseband, means for estimating the time delay of each signal, means for despreading  
20 the signal, and means for estimating of a SNIR-value (Signal to Noise and Interference Ratio) for each signal.

The estimated SNIR-values are transferred to a decision unit 303a, 303b. The decision unit decides which antenna sector or antenna sectors that are to be considered active depending of  
25 the estimated SNIR-values. The decision unit gives its decision to a selection unit 304a, 304b that selects the signals from the selected antenna sectors. The selected signals are then combined in a combination unit C1, C2 if more than one signal is selected.

If the system can perform channel estimations and channel compensation on uplink signals then coherent combining of uplink signals is possible.

In the present embodiment two logical sectors are active. The output of each of the uplink communication units 301a, 301b is a  
5 combined signal. The uplink apparatus further comprises a softer handoff combiner unit 305. This unit is activated by the control unit 302 when more than one logical sector is active. The softer handoff combination unit 305 combines signals from  
10 different logical sectors according to known methods of softer handoff combination. The softer handoff combination of signals could for instance be performed only for signals that have acceptable signal strength. The softer handoff combination unit 305 could then check the signal strengths of the signals.

15 If only one logical sector was decided to be active no softer handoff would have to be performed. More than one antenna sector within one logical sector could then be used in communication with a mobile station without having to perform a softer handoff. No softer handoff signaling would then have to be  
20 exchanged with the mobile station. The uplink apparatus further comprises a decoding unit 306 for decoding the resulting combined signal.

In Figure 5 one embodiment of a downlink apparatus for transmitting downlink signals within one cell according to the  
25 present invention is shown. The cell configuration is supposed to be like the one shown in Figure 3.

The downlink apparatus comprises a signal generator 401, a softer handoff distribution unit 402 for distributing the signal to different active logical sectors, and a control unit 302 for

controlling the softer handoff distribution unit. The control unit is supposed to be the same control unit as was shown in Figure 4. The downlink unit further comprises one downlink communication unit 403a, 403b for each logical sector, that is  
5 in this case two downlink communication units.

Each downlink communication unit comprises four transmitters T1,T3,T5,T7 and T2,T4,T6,T8 each connected to antenna means for generating one antenna lobe for each transmitter. Each antenna lobe covers an antenna sector. The transmitters are numbered  
10 according to the numbering in Figure 3.

The signal generator 401 generates a signal that is to be transmitted to a mobile station. The control unit 302 decides which logical sectors that are active in the same way as was described in conjunction with Figure 4. In the present example  
15 it is assumed that both logical sectors are active.

The control unit 302 further controls the softer handoff distribution unit so that it distributes the generated signal to the downlink communication unit 403a and 403b of each active logical sector. In the present example the softer handoff  
20 distribution unit 402 distributes the signal to both downlink communication units 403a and 403b.

Each downlink communication unit 403a and 403b comprises a decision unit 303a and 303b that in this embodiment is the same physical decision unit as in Figure 4. Each decision unit 303a,  
25 303b decides which antenna sector or antenna sectors that should be used for downlink communication. The decision is based on the estimated uplink SNIR-values for instance according to the different principles that was presented in conjunction with Figure 4.



The situation in the downlink is however somewhat different than in uplink. In the uplink communication it is most advantageous that the best signals, that is the signals with the highest instantaneous SNIR-values, are combined. In the downlink it could be more reliable to base the decision on several estimated SNIR-valued over a period of time. The decision unit 303a, 303b then has stored SNIR-values over a period of time.

The decision unit 303a, 303b controls a distribution unit 404a, 404b that distributes the signal to one or more transmitters T1-T8. Each transmitter T1-T8 comprises for instance up converters for up converting the signal from the baseband to the radio frequency band and power amplifiers. The signals are then transmitted from the transmitters T1-T8 covering the selected antenna sector.

In Figure 6 a flow diagram of an embodiment of the method of the invention for communication in uplink is shown. As was mentioned previously the base station selects one or a set of active logical sectors depending on signal quality measurements performed on the pilot channel in the downlink.

When the mobile station transmits information on a traffic channel all antenna means in the active logical sectors will listen to this channel and receive 501 a signal for every antenna sector. RAKE-combining can be used to combine several signals on the channel within one antenna sector. The SNIR-value is estimated 502 for each received signal. The signals are further processed according to known methods. A time delay estimation and despreading is performed for each received signal. Channel estimation and channel compensation can also be performed in systems where such operations are possible.

A number  $N$  of antenna sectors within each active logical sector are selected 503 for uplink communication with the mobile station. The selection is in the present embodiment based on estimated SNIR-value in one of the following ways.

5 The number of antenna sectors  $N$  that the base station can use in communication with a specific mobile station could be fixed according to a first embodiment of the present invention. In such an embodiment the  $N$  antenna sectors within a logical sector, belonging to the same logical sector, with the highest  
10 SNIR-value could be chosen for communication. The received signals from these antenna sectors will be combined.

According to a second embodiment of the present invention the antenna sectors belonging to the same logical sector, with a SNIR-value exceeding a predetermined threshold value are chosen  
15 for communication. The received signals from these antenna sectors will be combined.

According to a third embodiment of the present invention the antenna sectors within an active logical sector, with a SNIR-value exceeding  $P$  percent of the maximum estimated SNIR, for a  
20 fixed percentage  $P$  are chosen for communication. The received signals from these antenna sectors will be combined.

The signal that were received in the selected antenna sectors are combined 504. If channel estimation and channel combination has been performed the signals can be coherently combined. If  
25 more than one logical sector is active ( $Y$  in 505) the resulting signal after combination within each active logical sectors are softer handoff combined 506 according to known methods.

Thereafter the resulting signal is decoded 507 and further processed according to known methods. If only one logical sector was active (N in 505) the resulting signal after combination within this logical sector is decoded 507 and further processed according to known methods.

Signal quality measurements on the pilot channel is continuously performed and the decision whether a logical sector is active or not can therefore change during a call.

In Figure 7 a flow scheme of one embodiment of the method in present invention for communication in the downlink within one cell is shown. It is assumed that it has been decided which logical sector or sectors that are active.

A signal is generated 601. If more than one logical sector is active (Y in 602) a softer handoff distribution 603 of the signal to the respective active logical sectors is performed according to known methods. One or more antenna sectors are selected 604 for communication with the mobile station in downlink. The selection is based on the SNIR-values that were estimated for the received uplink signals according to the description in conjunction with step 502 in Figure 6.

The selection can be based on the SNIR-values according to the same alternatives as was described in conjunction with Figure 6. It could be more reliable to consider SNIR-values over a period of time in the downlink in order to transmit signals in antenna sectors wherein the mobile station has received signals with satisfying quality over a period of time.

The signal is then further processed including up conversion to the RF-band and power amplification, according to known methods.

The processed signal is then transmitted 605 in each of the selected antenna sectors.

The invention makes it possible to sectorize a cell in a CDMA-system that uses the pilot channel to perform handoff  
5 measurements and for coherent demodulation of signals in the downlink without using different pilot channels in every antenna sector. The number of pilot channels is below the number of antenna sectors within a cell.

Signals from more than one antenna sector can be combined and if  
10 signals from only one logical sector are combined no softer handoff has to be performed.

The CDMA-system according to the invention has in the preferred  
embodiments been described as comprising base stations and  
mobile stations. More generally a base station can be thought of  
15 as a primary station and a mobile station can be thought of as a secondary station.

**CLAIMS**

1. A cellular CDMA-system comprising at least one primary station (BS) and at least one secondary station, said primary station comprising antenna means for generating at least four  
5 directional antenna beams, each antenna beam covering an antenna sector (AS1-AS8) of a cell (CELL), wherein each antenna sector is partially overlapped by at least one other antenna sector, and wherein each sectorized cell is allocated at least two different pilot channels (P1, P2), c h a r a c t e r i z e d i n  
10 that the primary station further comprises means (T1-T8) for transmitting different pilot channels (P1,P2), from the allocated pilot channels, in antenna sectors that have a common overlapping region, and for transmitting at least one of the pilot channels in at least two antenna sectors that have  
15 essentially no common overlapping region.
2. A cellular CDMA-system according to Claim 1, wherein antenna sectors (AS1,AS3,AS5,AS7;AS2,AS4,AS6,AS8) having the same pilot channel (P1,P2) constitutes a logical sector (LS1, LS2).
3. A cellular CDMA-system according to any of Claims 1 and 2,  
20 further comprising:  
a control unit (302) for selecting at least one logical sector (LS1,SL2) as active for a secondary station in the cell;  
and  
means for communicating with said secondary station in  
25 uplink and downlink within said at least one logical sector.
4. A cellular CDMA-system according to any of Claims 1-3, wherein the antenna means comprises antenna arrays.

5. A cellular CDMA-system according to any of Claims 1-3, wherein the antenna means comprises sector antennae.

6. A cellular CDMA-system according to any of Claims 2-5 wherein said means for communicating with said secondary station in the uplink comprises:

an uplink communication unit (301a,301b) for each logical sector (LS1,LS2) for receiving signals from antenna sectors (AS1-AS8) within one logical sector (LS1,LS2) and for combining said signals;

a softer handoff combiner unit (305) for combining signals from different logical sectors; and

a decoding unit (306) for decoding received signals.

7. A cellular CDMA-system according to Claim 6, wherein said uplink communication unit (301a, 301b) further comprises:

a receiver (R1-R8) for each antenna sector (AS1-AS8), for receiving uplink signals from a secondary station;

a signal processing unit (S1-S8) for each antenna sector for estimating time delay and for despreading the received signal and for measuring a signal quality parameter (SNIR);

a decision unit (303a,303b) for deciding which antenna sectors that should be used for uplink communication in dependence of the measured signal quality parameter (SNIR);

a selection unit (304a,304b) for selecting the signals received from the antenna sectors that should be used for uplink communication; and

a combiner unit (C1,C2) for combining the selected signals if signals from more than one antenna sector is selected.

8. A cellular CDMA-system according to any of Claims 6 and 7, wherein said uplink communication unit (301a, 301b) further

comprises:

means for performing coherent combination of received signals within the logical sector (LS1,LS2).

9. A cellular CDMA-system according to any of Claims 2-8, wherein said means for communicating with said secondary station in the downlink comprises:

a signal generating unit (401) for generating a signal;

a softer handoff distribution unit (402) for distributing said signal to active logical sectors (LS1,LS2);

10 a downlink communication unit (403a,403b) for each logical sector for selecting at least one antenna sector (AS1-AS8) within an active logical sector and for transmitting signals to a secondary station within said selected antenna sectors.

15 10. A cellular CDMA-system according to Claim 9, wherein said downlink communication unit comprises:

a decision unit (303a, 303b) for deciding which antenna sectors that should be used for communication with the secondary station;

20 a distribution unit (404a,404b) for distributing the signal to each antenna sector that should be used for downlink communication; and

a transmitter (T1-T8) for each antenna sector (AS1-AS8) for transmitting signals if the antenna sector is to be used in downlink communication.

11. A cellular CDMA-system according to any of Claims 1-10, wherein said primary station is a base station.

12. A cellular CDMA-system, according to any of Claims 1-11, wherein said secondary station is a mobile station.

13. A method in a cellular CDMA-system, which CDMA-system comprises at least one primary station (BS) and at least one secondary station (MS), said primary station comprising antenna means for generating at least four directional antenna beams, each beam covering an antenna sector (AS1-AS8) of a cell (CELL), wherein each antenna sector is partially overlapped by at least one other antenna sector, and wherein each sectorized cell is allocated at least two different pilot channels (P1,P2), wherein the method for each sectorized cell comprises the steps:

10           b) transmitting different pilot channels (P1,P2), from the allocated pilot channels, in antenna sectors having common overlapping regions;

            c) transmitting at least one of said pilot channels (P1,P2) in at least two antenna sectors (AS1-AS8) having essentially no common overlapping region.

14. A method according to Claim 13, wherein antenna sectors (AS1,AS3,AS5,AS7;AS2,AS4,AS6,AS8) having the same pilot channel (P1,P2) constitute a logical sector (LS1,LS2); and wherein the method further comprises

20           communicating in uplink and downlink with a secondary station within at least one logical sector (LS1-LS2).

15. A method according to Claim 14, wherein said communication with a secondary station within at least one logical sector comprises the steps:

25           a) measuring a signal quality parameter of the pilot channel (P1,P2);

            b) selecting at least one logical sector (LS1,LS2) as active in dependence of the measured signal quality parameter; and

30           c) communicating in uplink and downlink with the secondary



station within at least one antenna sector (AS1-AS8) within each active logical sector (LS1,LS2).

16. A method according to Claim 15, wherein said step of communicating with the secondary station within at least one antenna sector (AS1-AS8) within each logical sector (LS1,LS2) in the uplink comprises the steps:

a) receiving (501) signals from the secondary station in the antenna sectors within each active logical sector;

b) estimating (502) a signal quality parameter for the received signals;

c) selecting (503) at least one antenna sector for communication in dependence of the estimated quality parameter;

d) combining (504) the received signals from the selected antenna sectors within each active logical sector if more than one antenna sector is selected;

e) softer handoff combining (506) the combined signals from all active logical sectors, if more than one logical sector is active (Y in 505), resulting in one signal; and

f) decoding (507) the resulting signal.

17. A method according to Claim 15, wherein only one logical sector (LS1,LS2) is permitted to be selected as active, wherein said step of communicating with the secondary station within at least one antenna sector (AS1-AS8) within each logical sector (LS1,LS2) in the uplink comprises the steps:

a) receiving signals (501) from the secondary station in the antenna sectors within the active logical sector;

b) estimating (502) signal quality parameter for the received signals;

c) selecting (503) at least one antenna sector for communication in dependence of the estimated quality parameter;

d) combining (504) of the received signals from the selected antenna sectors if more than one antenna sector is selected;

e) decoding (507) the resulting signal.

5 18. A method according to any of Claims 16 and 17, wherein the received signals within each logical sector (LS1,LS2) are coherently combined.

19. A method according to any of Claims 14-18, wherein said step of communicating with the secondary station within at least one  
10 antenna sector (AS1-AS8) within each logical sector (LS1-LS2) in the downlink comprises the steps:

a) generating (601) a signal;

b) softer handoff distributing (603) the signal to all active logical sectors if more than one logical sector is active  
15 (Y in 602); and

c) selecting (604) at least one antenna sector for downlink communication in dependence of an estimated quality parameter of uplink signals; and

d) transmitting (605) the signal to the secondary station  
20 in the selected antenna sectors.

20. A method according to any of claims 13-19, wherein said primary station is a base station.

21. A method according to any of Claims 13-20, wherein said secondary station is a mobile station.

1/6

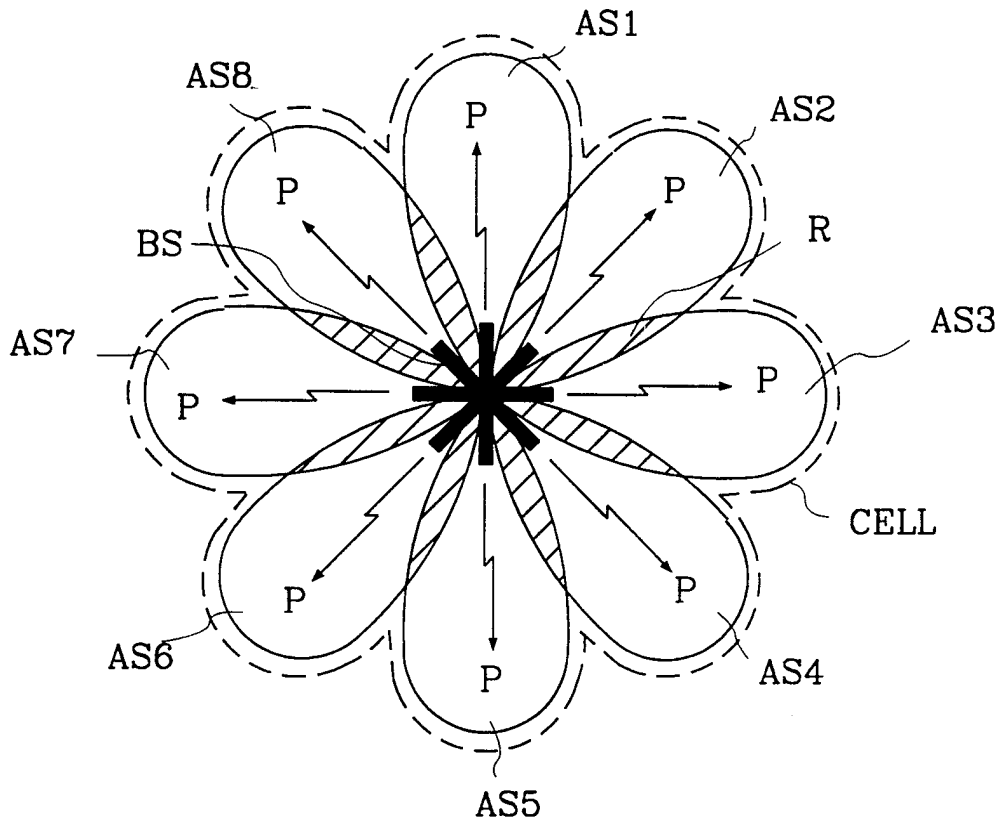

Fig. 1

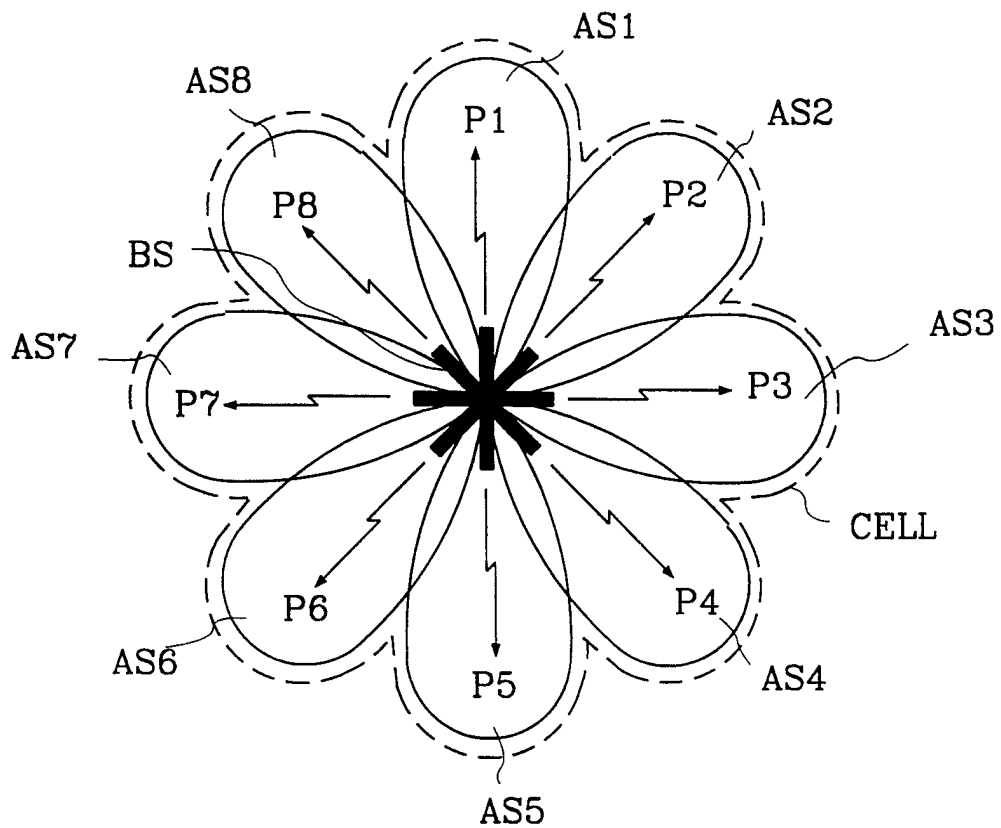

Fig. 2

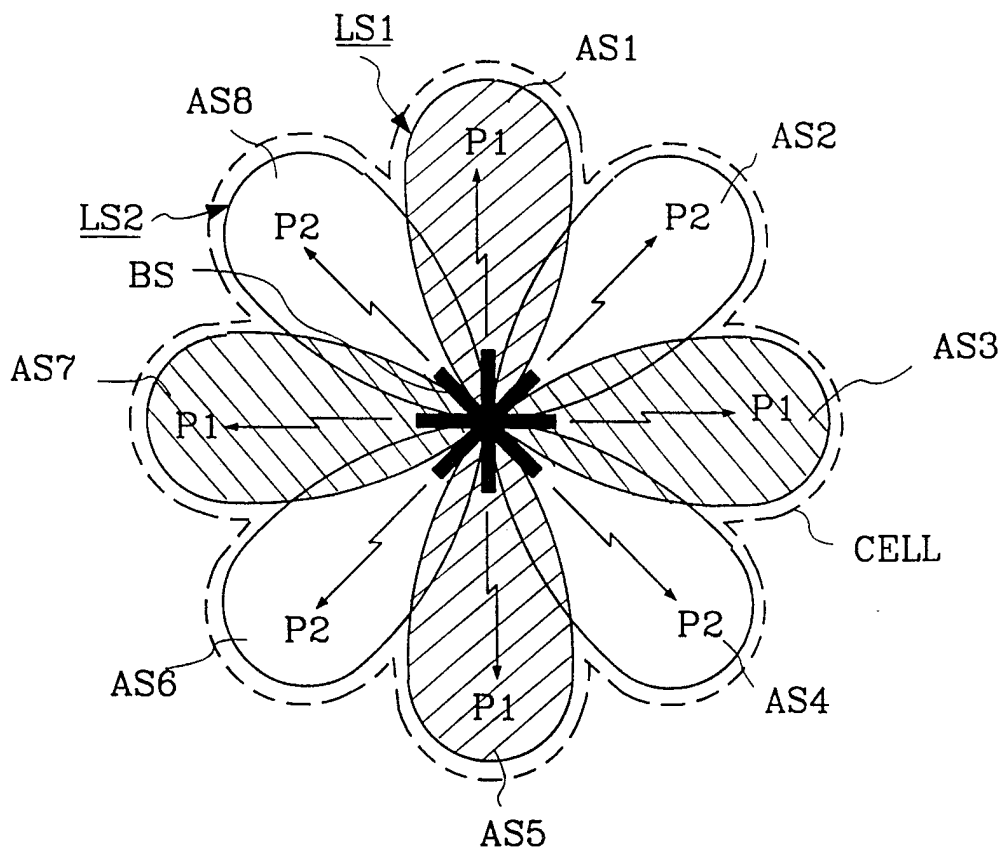

Fig.3

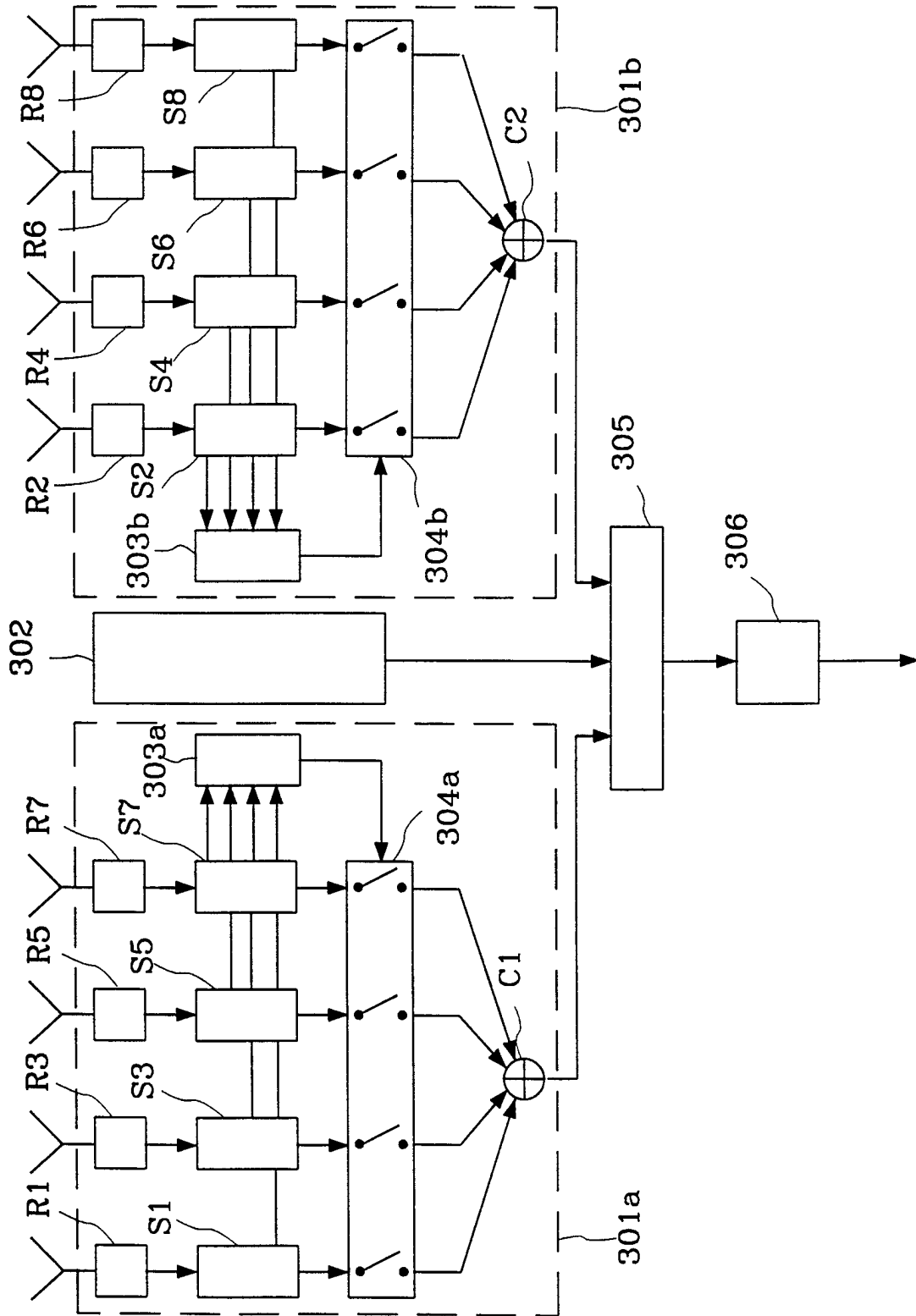

Fig. 4

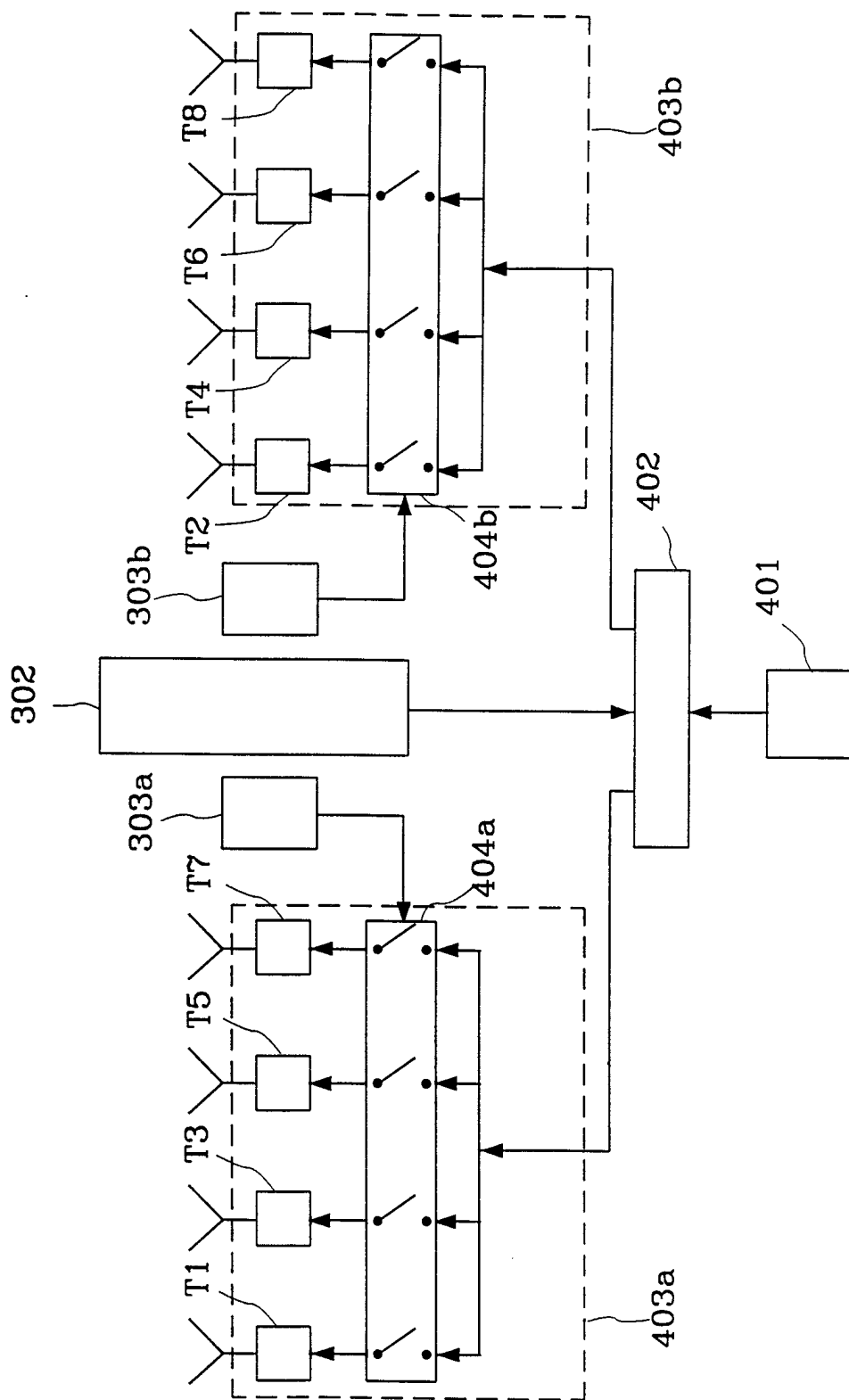

Fig.5

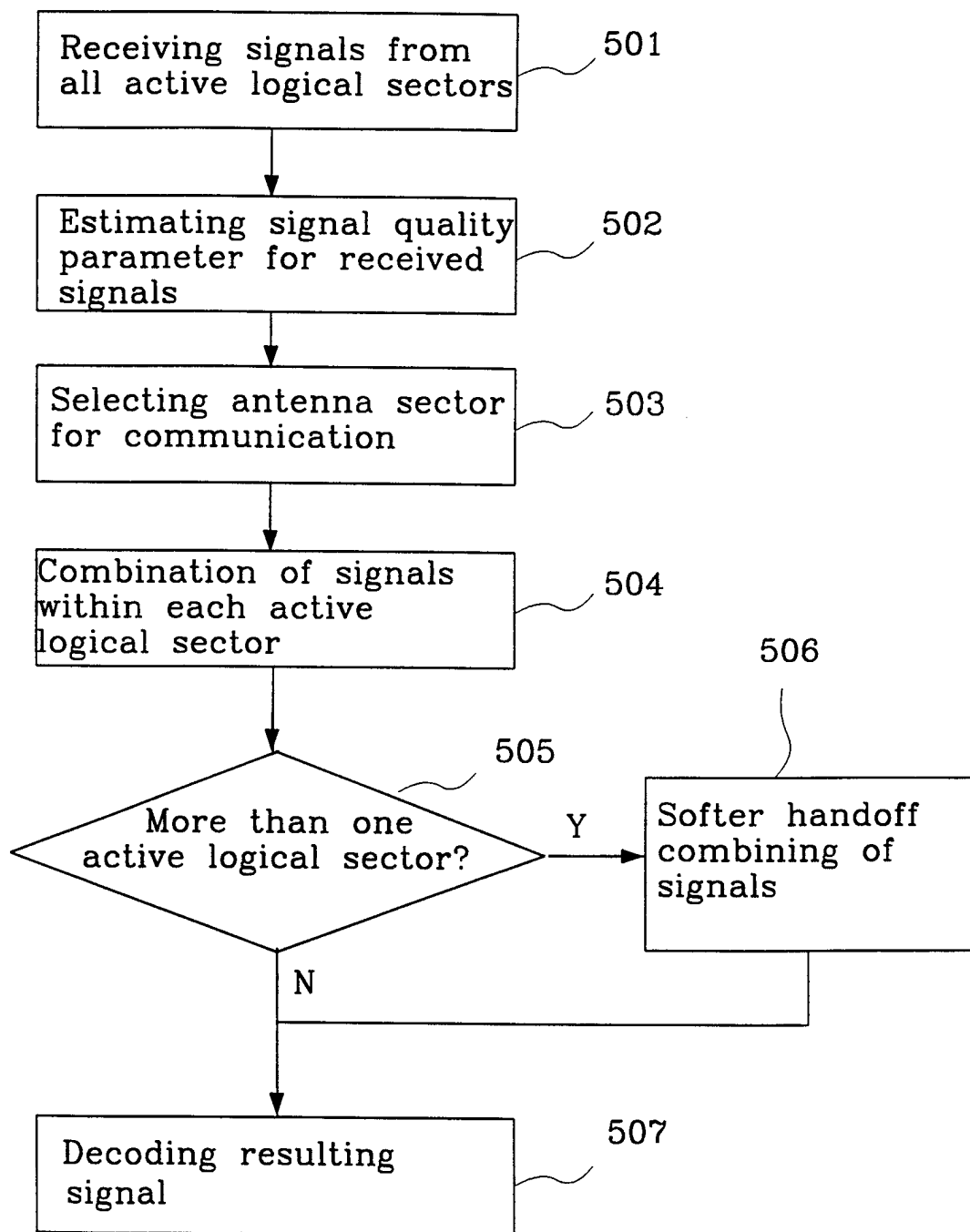

Fig.6

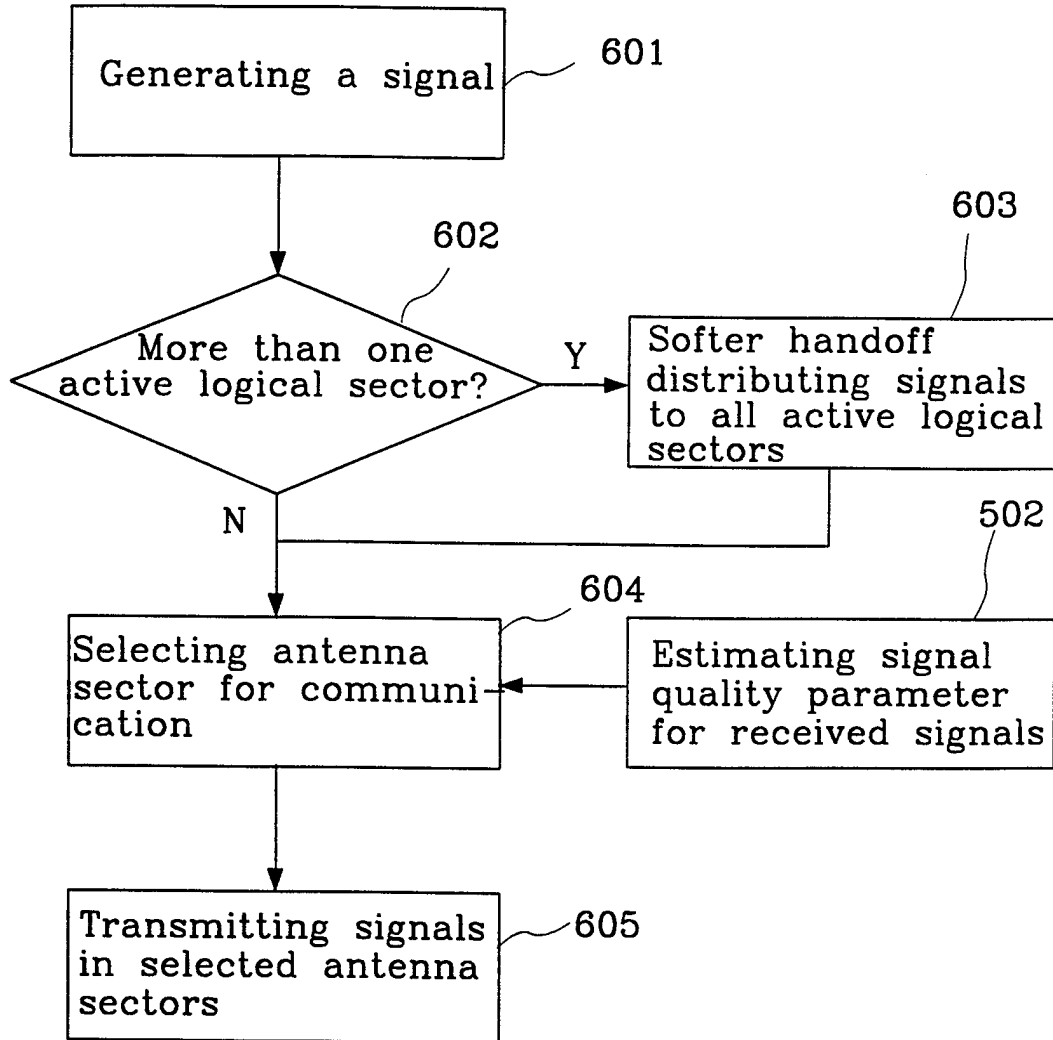

Fig.7



## INTERNATIONAL SEARCH REPORT

International application No.

PCT/SE 98/00993

A. CLASSIFICATION OF SUBJECT MATTER		
<b>IPC6: H04Q 7/36</b> According to International Patent Classification (IPC) or to both national classification and IPC		
B. FIELDS SEARCHED		
Minimum documentation searched (classification system followed by classification symbols)		
<b>IPC6: H04B, H04Q</b>		
Documentation searched other than minimum documentation to the extent that such documents are included in the fields searched		
<b>SE,DK,FI,NO classes as above</b>		
Electronic data base consulted during the international search (name of data base and, where practicable, search terms used)		
<b>WPIL, EDOC</b>		
C. DOCUMENTS CONSIDERED TO BE RELEVANT		
Category*	Citation of document, with indication, where appropriate, of the relevant passages	Relevant to claim No.
X	US 5561842 A (GERHARD RITTER ET AL), 1 October 1996 (01.10.96), figures 1-4b  --	1-5,11-14, 20,21
A	US 5697057 A (JACQUES BURSZTEJN ET AL), 9 December 1997 (09.12.97), column 1, line 35 - line 42; column 5, line 43 - line 54; column 7, line 11 - line 14  -- -----	
<input type="checkbox"/> Further documents are listed in the continuation of Box C. <input checked="" type="checkbox"/> See patent family annex.		
* Special categories of cited documents: "A" document defining the general state of the art which is not considered to be of particular relevance "E" earlier document but published on or after the international filing date "L" document which may throw doubts on priority claim(s) or which is cited to establish the publication date of another citation or other special reason (as specified) "O" document referring to an oral disclosure, use, exhibition or other means "P" document published prior to the international filing date but later than the priority date claimed		"T" later document published after the international filing date or priority date and not in conflict with the application but cited to understand the principle or theory underlying the invention "X" document of particular relevance: the claimed invention cannot be considered novel or cannot be considered to involve an inventive step when the document is taken alone "Y" document of particular relevance: the claimed invention cannot be considered to involve an inventive step when the document is combined with one or more other such documents, such combination being obvious to a person skilled in the art "&" document member of the same patent family
Date of the actual completion of the international search		Date of mailing of the international search report
1 October 1998		09-10-1998
Name and mailing address of the ISA/ Swedish Patent Office Box 5055, S-102 42 STOCKHOLM Facsimile No. +46 8 666 02 86		Authorized officer  Malin Gullstrand Telephone No. +46 8 782 25 00

**INTERNATIONAL SEARCH REPORT**

Information on patent family members

27/07/98

International application No.

PCT/SE 98/00993

Patent document cited in search report	Publication date	Patent family member(s)	Publication date
US 5561842 A	01/10/96	EP 0657074 A FI 950839 A WO 9405096 A	14/06/95 23/02/95 03/03/94
US 5697057 A	09/12/97	AU 683544 B AU 2019895 A CA 2150069 A CN 1119818 A EP 0684745 A FI 952477 A FR 2720574 A,B JP 7327262 A NZ 272138 A	13/11/97 30/11/95 26/11/95 03/04/96 29/11/95 26/11/95 01/12/95 12/12/95 24/02/97