



US 20140364725A1

(19) **United States**
(12) **Patent Application Publication**
Makower

(10) **Pub. No.: US 2014/0364725 A1**
(43) **Pub. Date: Dec. 11, 2014**

(54) **SYSTEMS AND METHODS FOR PERFORMING IMAGE GUIDED PROCEDURES WITHIN THE EAR, NOSE, THROAT AND PARANASAL SINUSES**

which is a continuation-in-part of application No. 10/912,578, filed on Aug. 4, 2004, now Pat. No. 7,361,168, which is a continuation-in-part of application No. 10/829,917, filed on Apr. 21, 2004, now Pat. No. 7,654,997.

(71) Applicant: **Acclarent, Inc.**, Menlo Park, CA (US)
(72) Inventor: **Joshua Makower**, Los Altos, CA (US)
(21) Appl. No.: **14/464,948**
(22) Filed: **Aug. 21, 2014**

Related U.S. Application Data

(63) Continuation of application No. 11/436,892, filed on May 17, 2006, which is a continuation-in-part of application No. 11/116,118, filed on Apr. 26, 2005, now Pat. No. 7,720,521, which is a continuation-in-part of application No. 11/037,548, filed on Jan. 18, 2005, now Pat. No. 7,462,175, which is a continuation-in-part of application No. 10/944,270, filed on Sep. 17, 2004, now abandoned, said application No. 11/116,118 is a continuation-in-part of application No. 10/944,270, filed on Sep. 17, 2004, now abandoned,

Publication Classification

(51) **Int. Cl.**
A61B 5/06 (2006.01)
A61B 6/03 (2006.01)
A61B 6/00 (2006.01)
A61M 29/02 (2006.01)
(52) **U.S. Cl.**
CPC *A61B 5/062* (2013.01); *A61M 29/02* (2013.01); *A61B 6/032* (2013.01); *A61B 6/037* (2013.01); *A61B 6/463* (2013.01)
USPC **600/424**

(57) **ABSTRACT**

Devices, systems and methods for performing image guided interventional and surgical procedures, including various procedures to treat sinusitis and other disorders of the paranasal sinuses, ears, nose or throat.

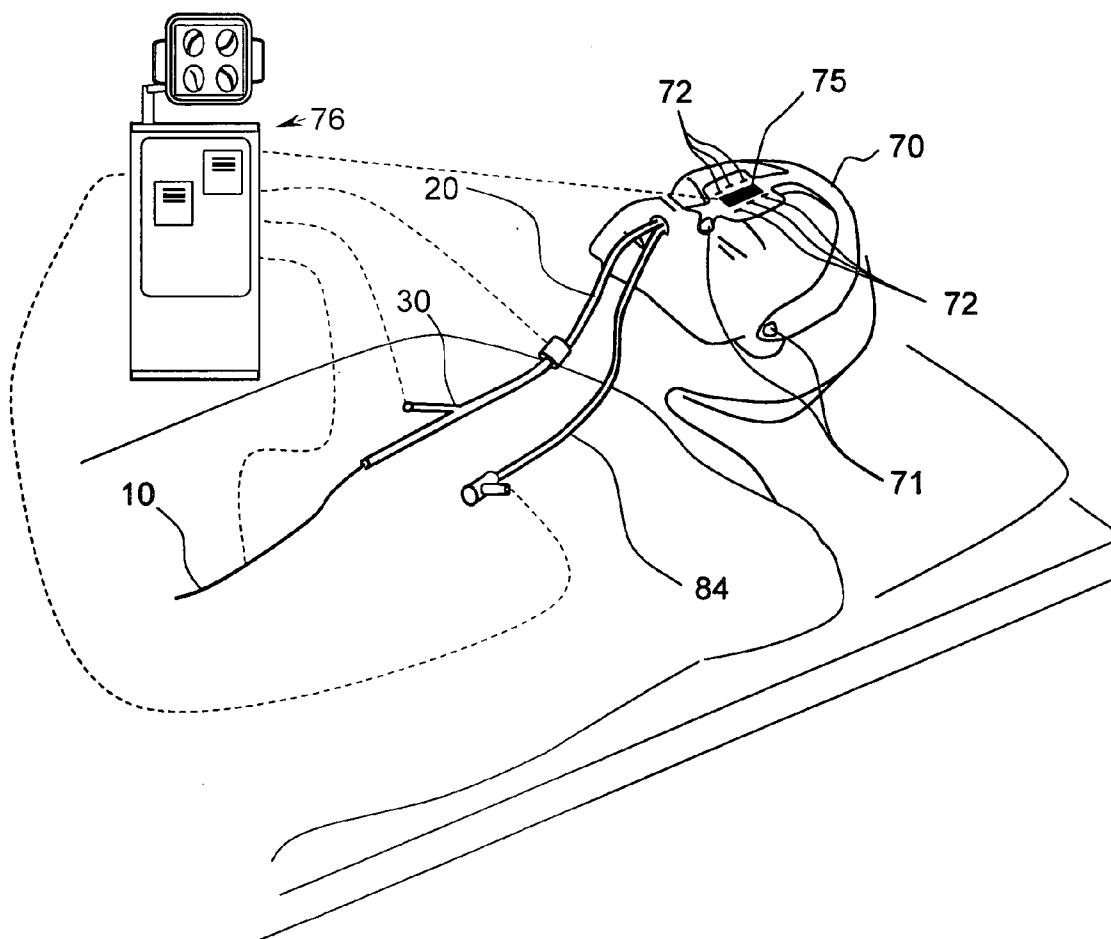

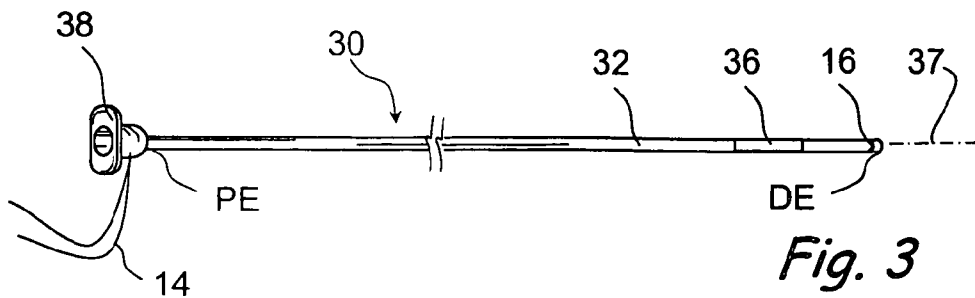
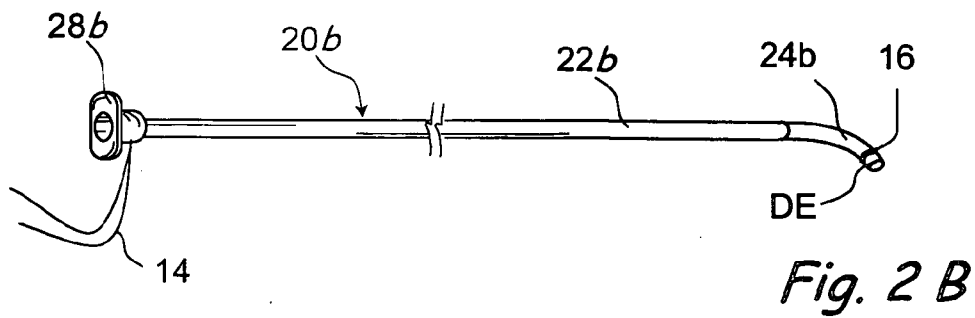
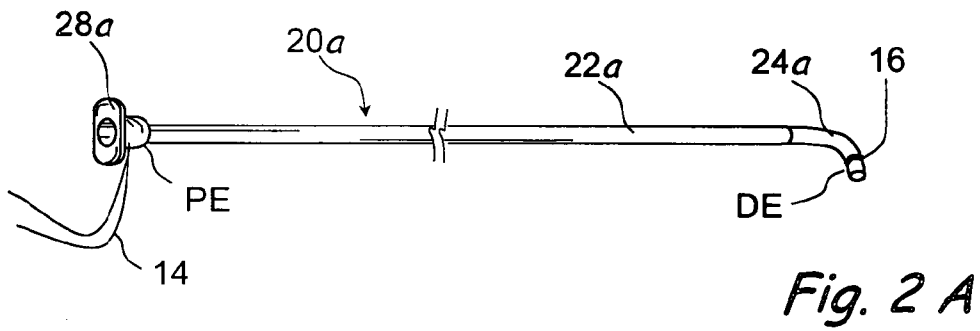
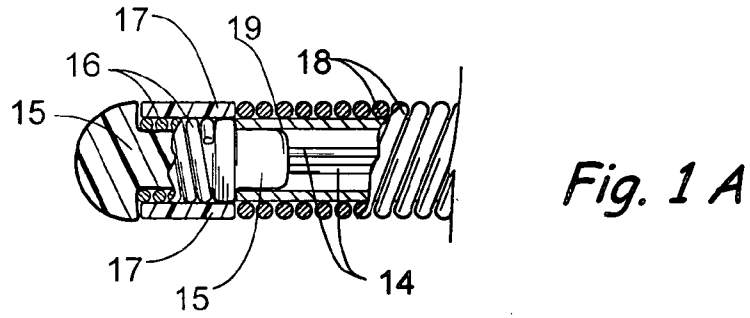
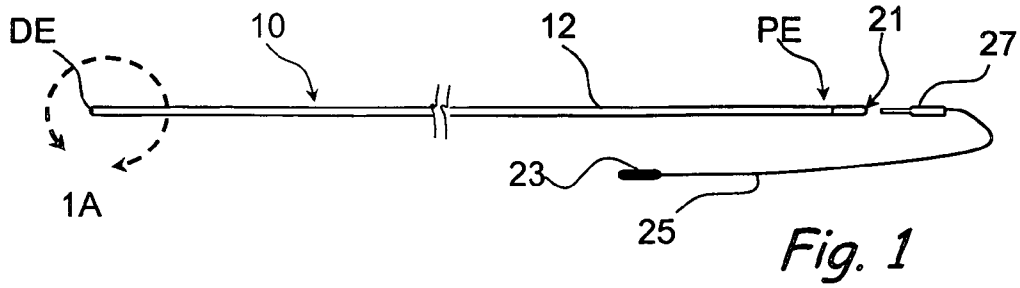

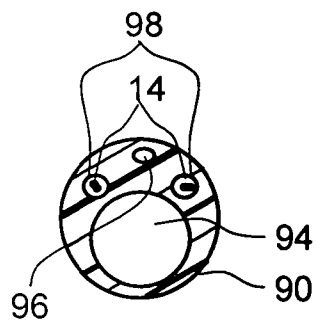
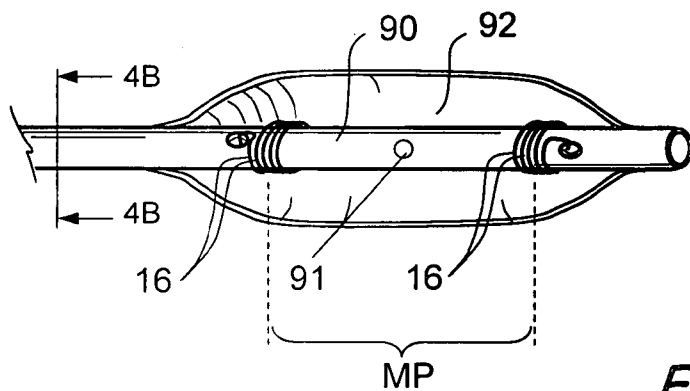
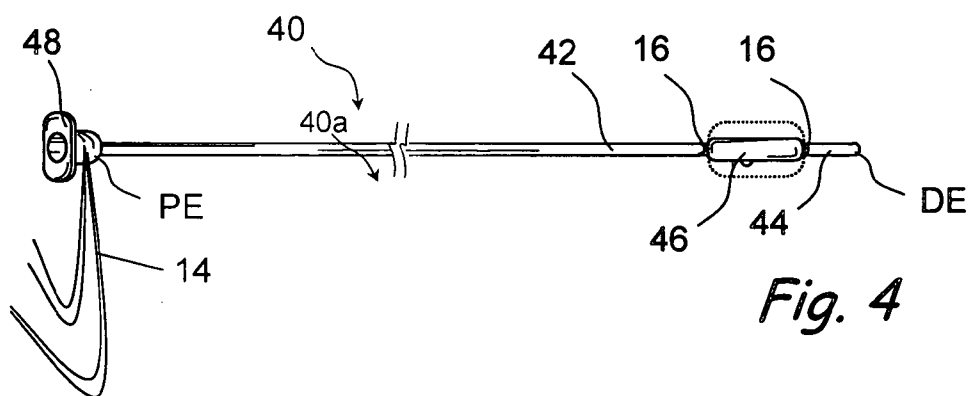

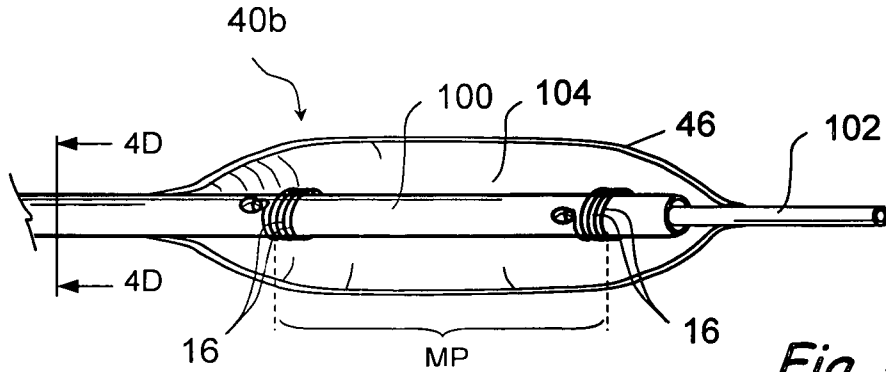

Fig. 4 C

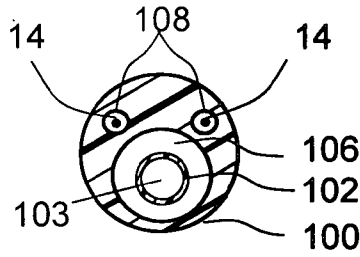

Fig. 4 D

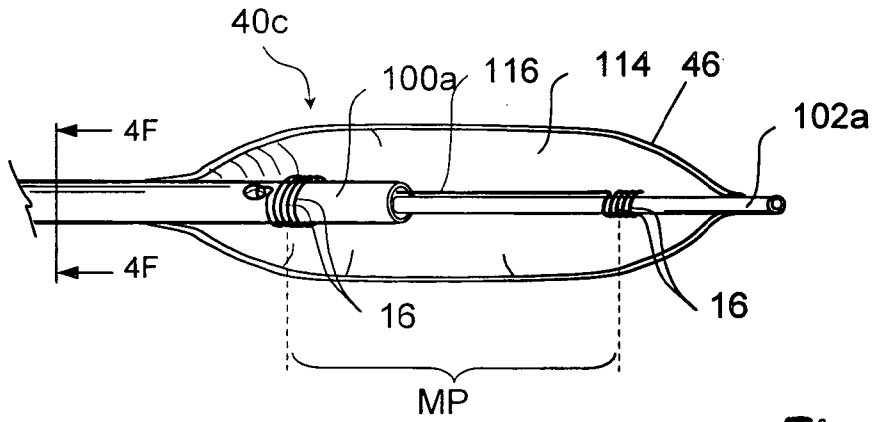

Fig. 4 E

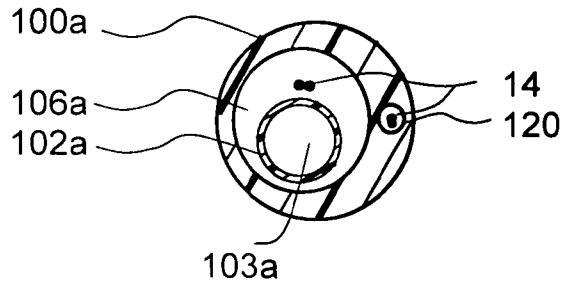

Fig. 4 F

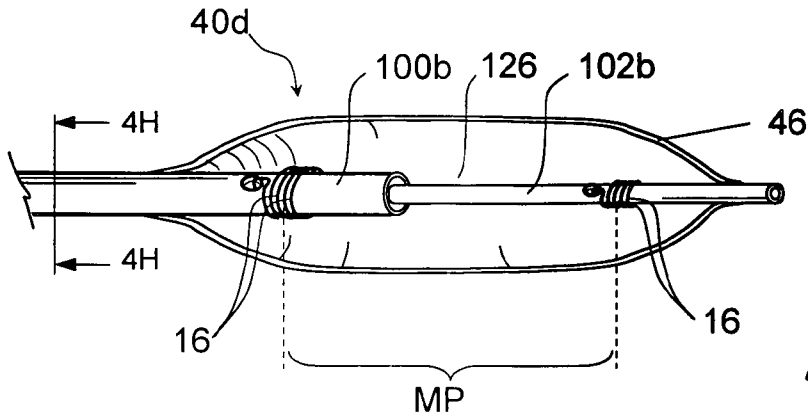

Fig. 4 G

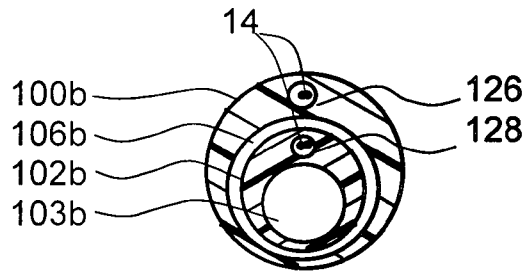

Fig. 4 H

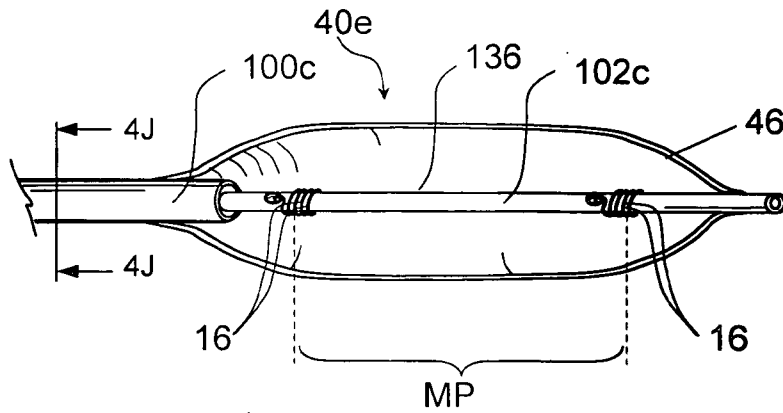

Fig. 4 I

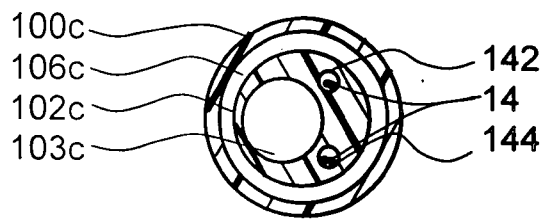

Fig. 4 J

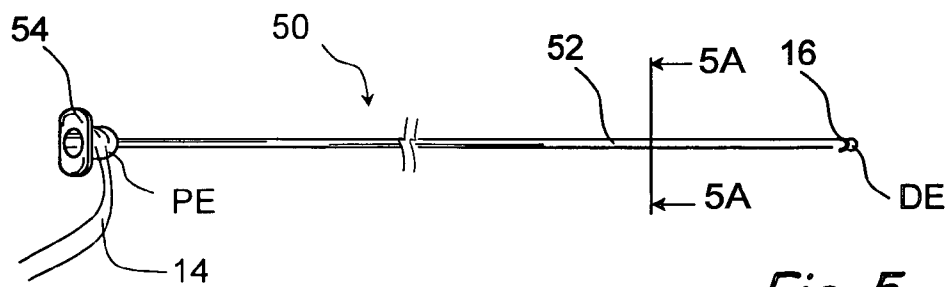

Fig. 5

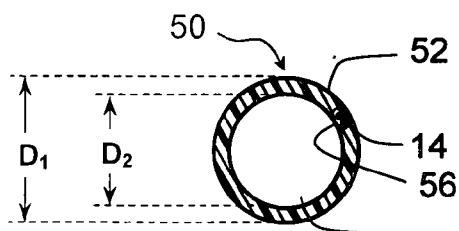

Fig. 5 A

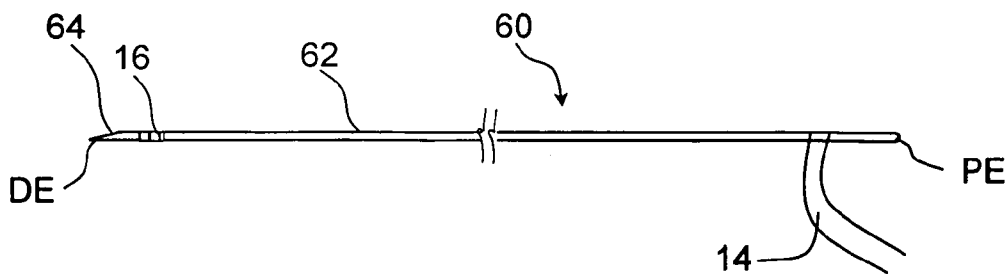

Fig. 6

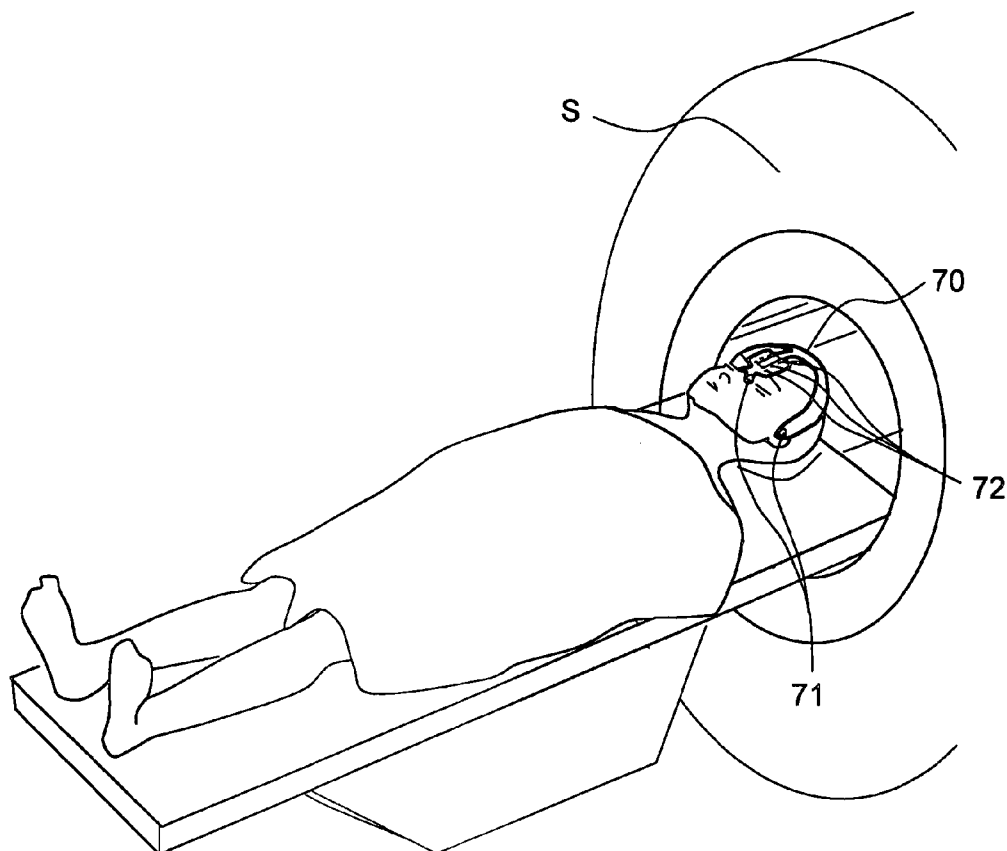

Fig. 7 A

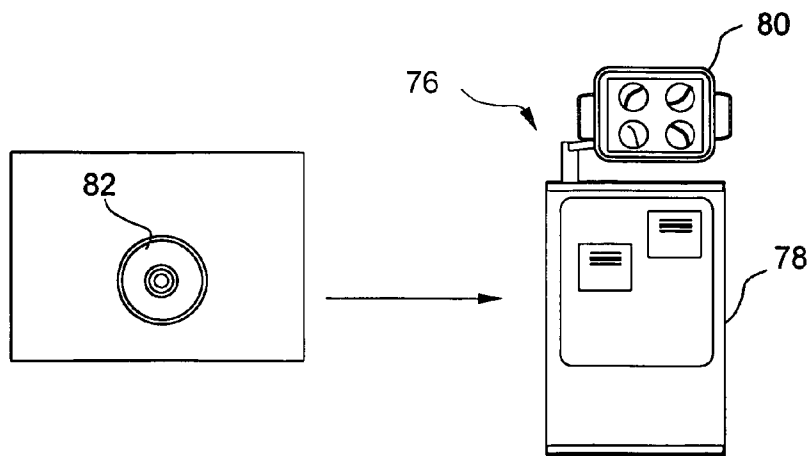

Fig. 7 B

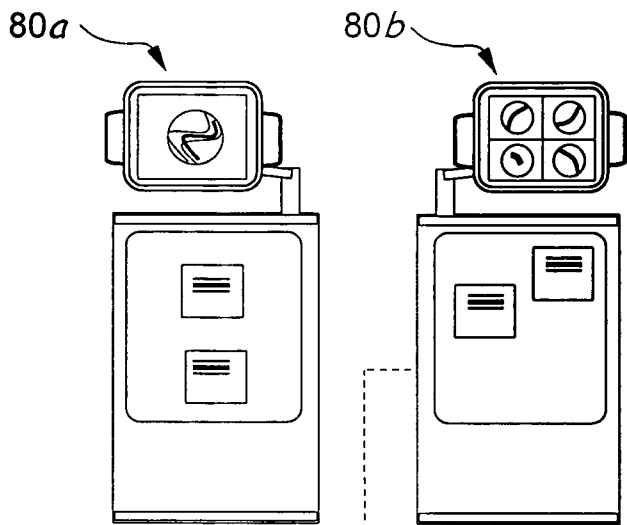

Fig. 7C

Fig. 7D

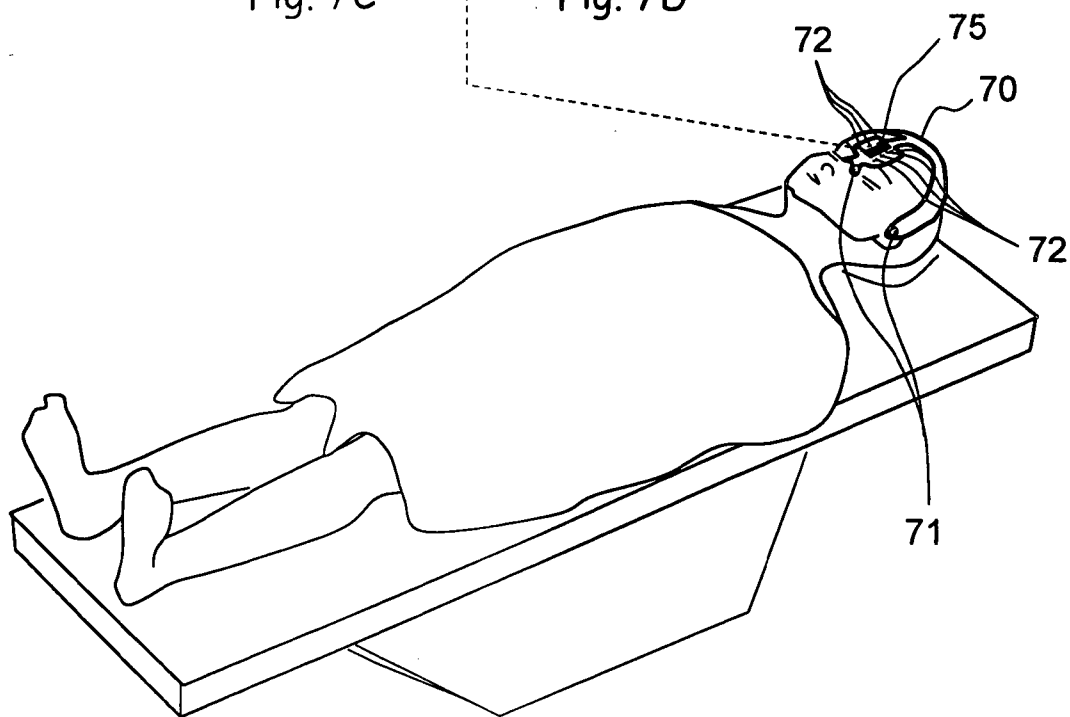

Fig. 7E

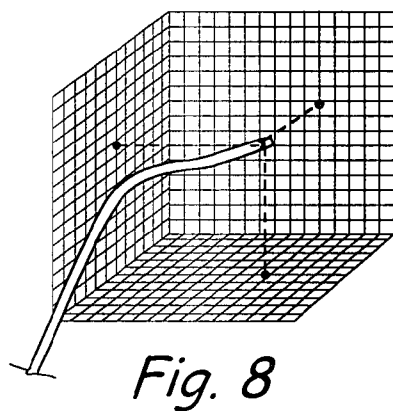

Fig. 8

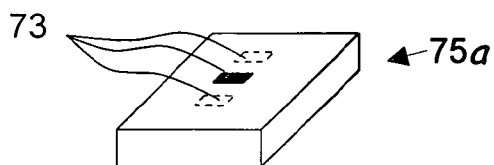

Fig. 8A

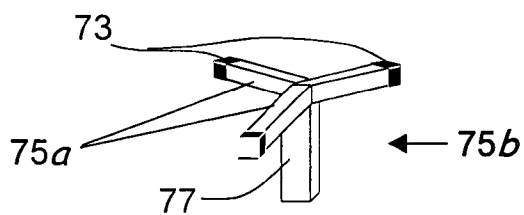

Fig. 8B

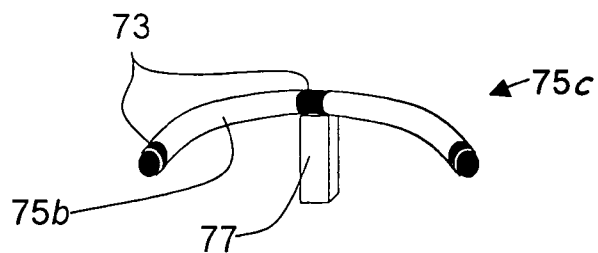
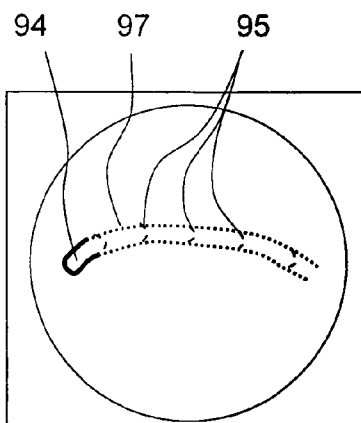
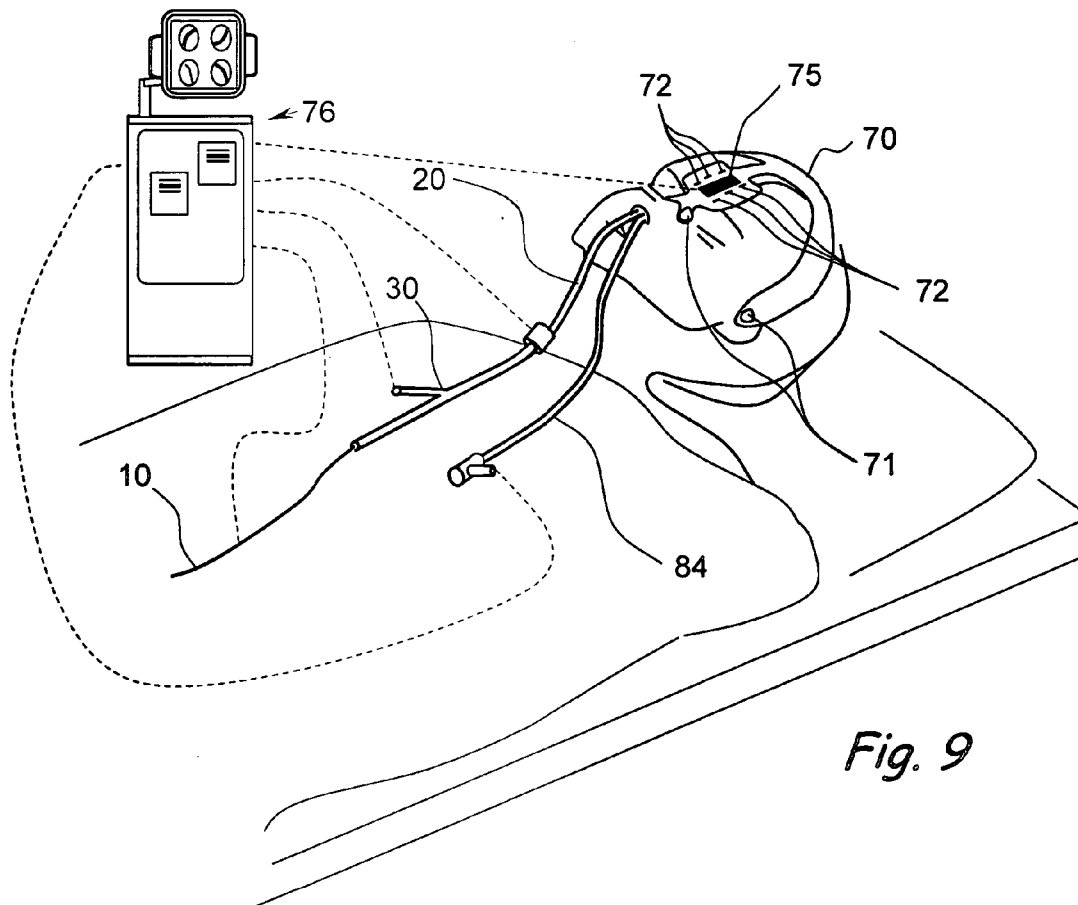

Fig. 8C



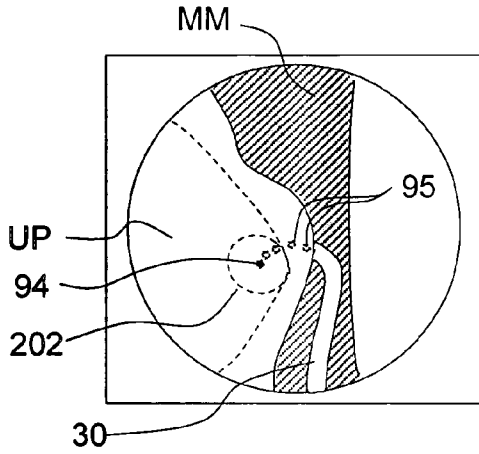

Fig. 10A

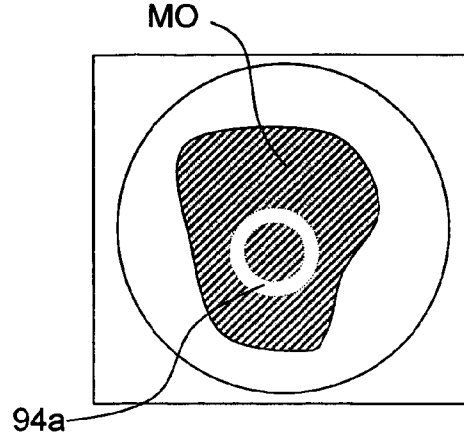

Fig. 10B

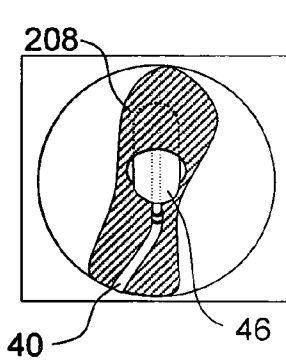

Fig. 11A

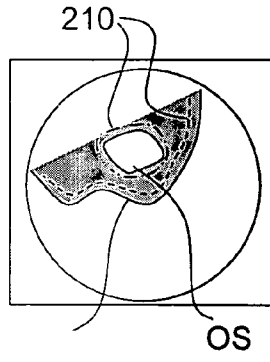

Fig. 11B

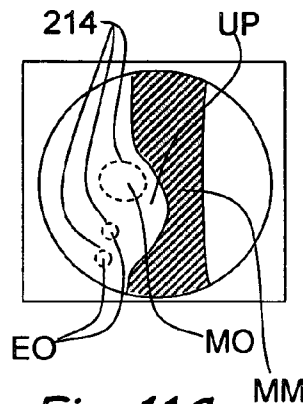

Fig. 11C

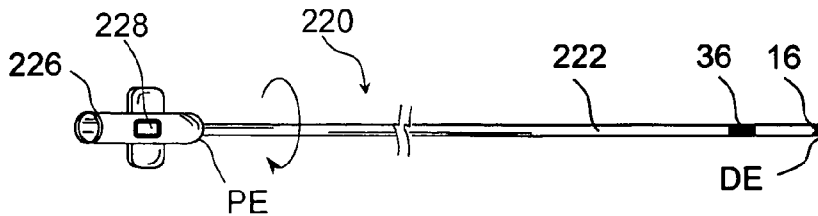

Fig. 12

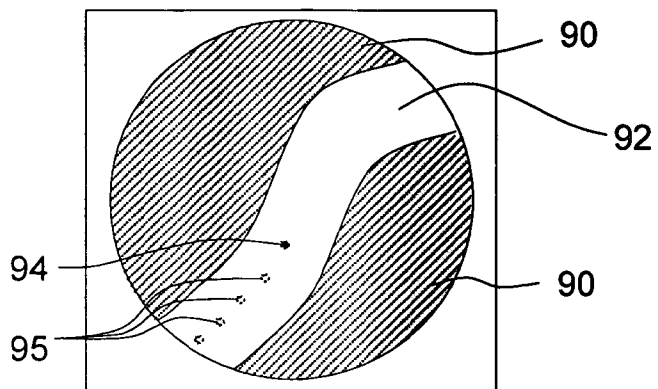

Fig. 13A

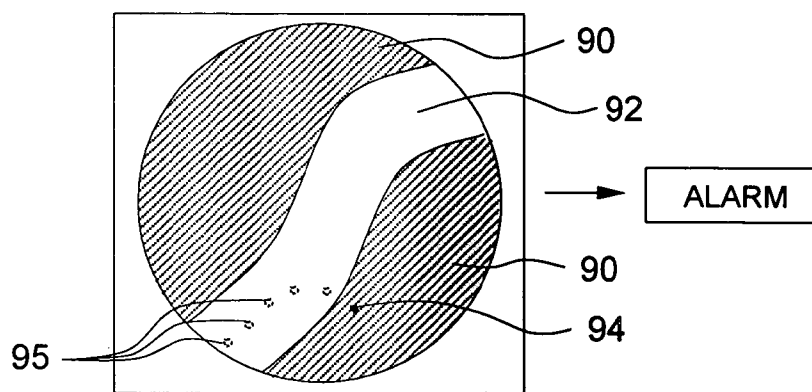

Fig. 13B

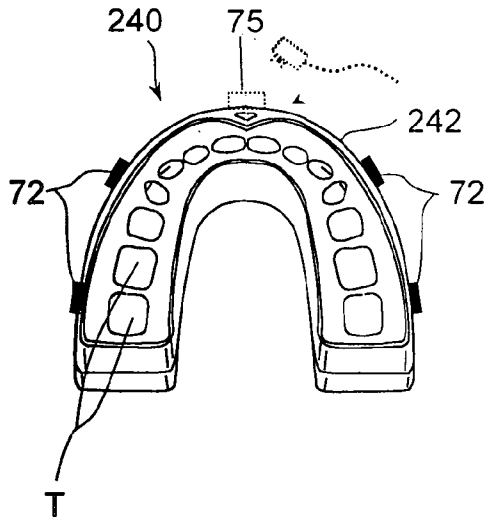

Fig. 14A

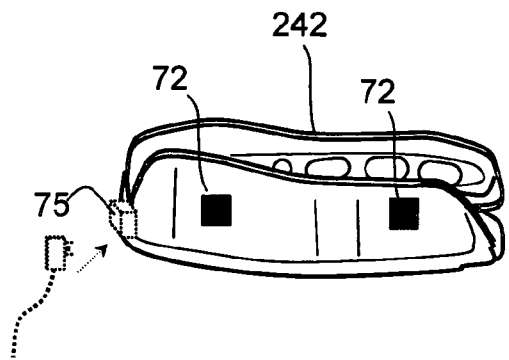

Fig. 14B

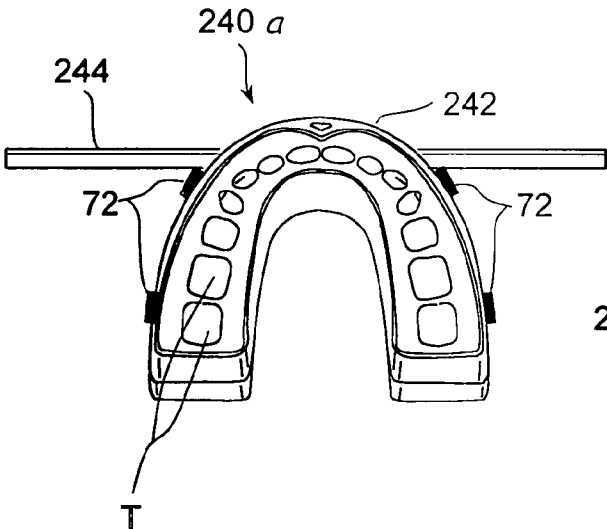

Fig. 15A

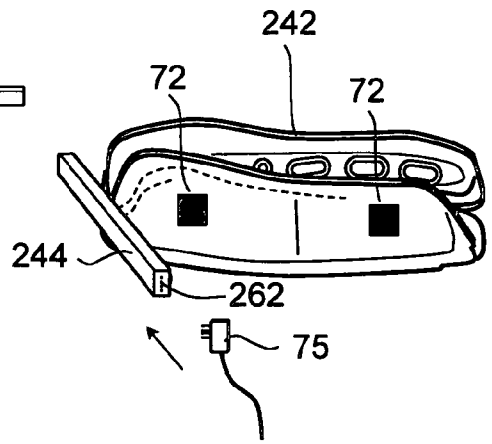

Fig. 15B

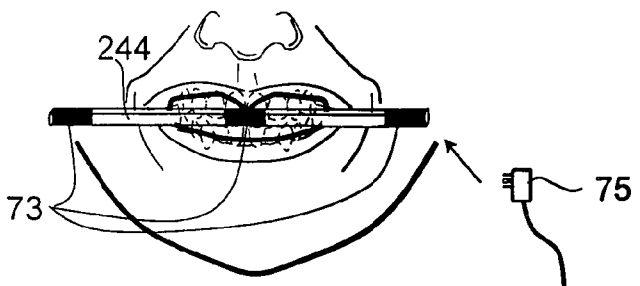

Fig. 15C

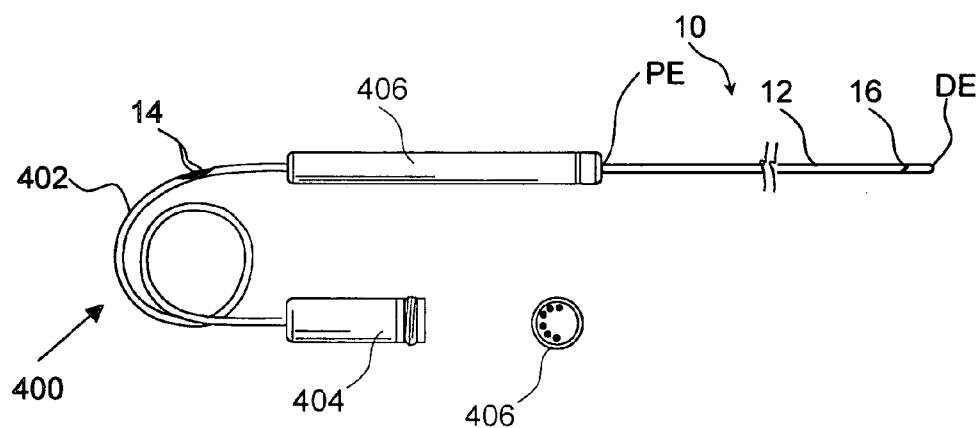

Fig. 16

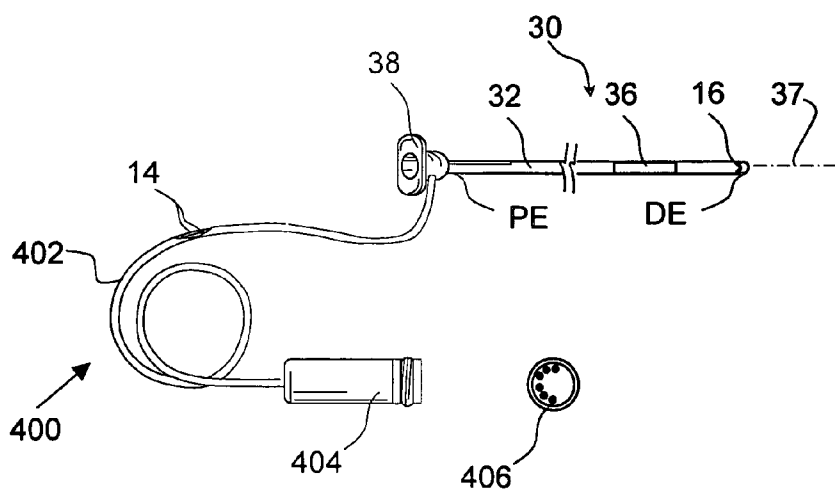

Fig. 17

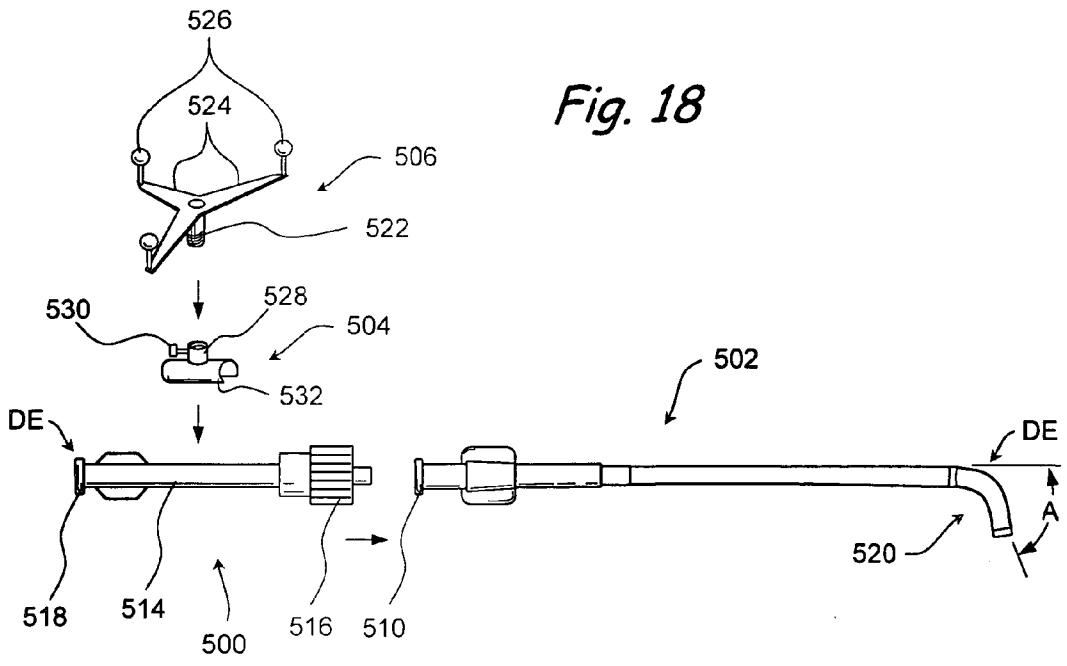

Fig. 18

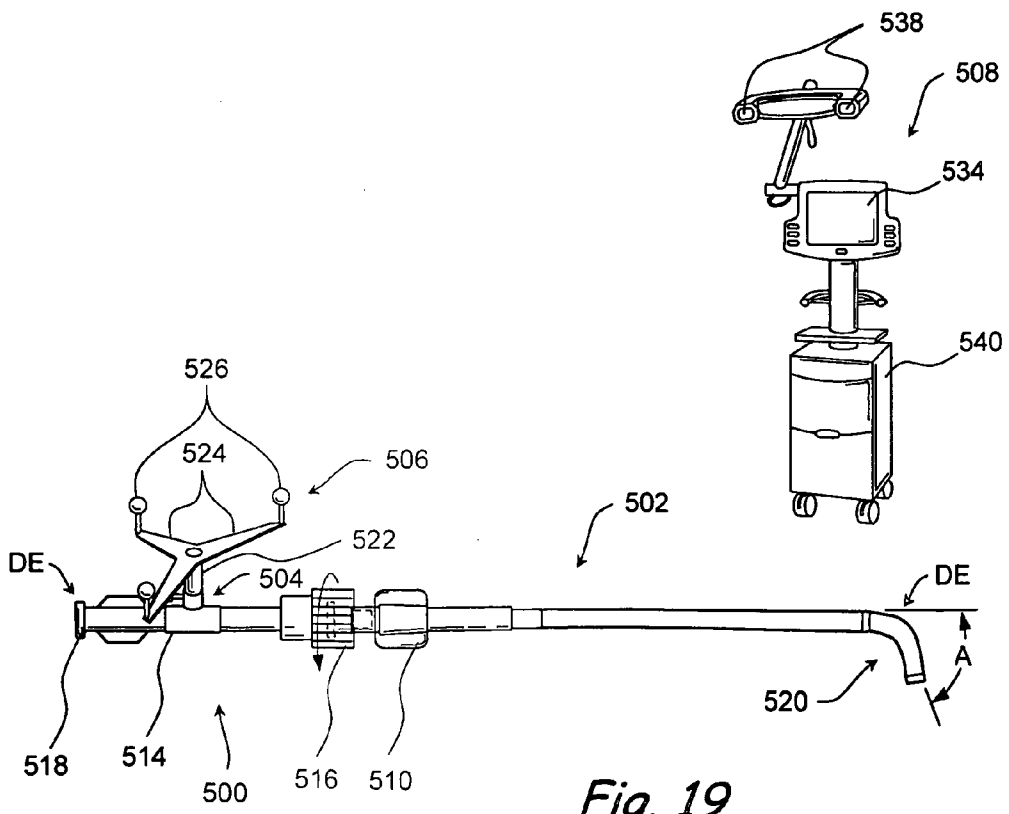

Fig. 19

SYSTEMS AND METHODS FOR PERFORMING IMAGE GUIDED PROCEDURES WITHIN THE EAR, NOSE, THROAT AND PARANASAL SINUSES

RELATED APPLICATION

[0001] This application is a continuation-in-part of U.S. patent application Ser. No. 11/116,118 entitled “Methods And Devices For Performing Image Guided Procedures Within The Ear, Nose, Throat And Paranasal Sinuses” filed Apr. 26, 2005 which is a continuation in part of four earlier-filed applications, namely 1) U.S. patent application Ser. No. 10/829,917 entitled “Devices, Systems and Methods for Diagnosing and Treating Sinusitis and Other Disorders of the Ears, Nose and/or Throat” filed on Apr. 21, 2004, 2) U.S. patent application Ser. No. 10/912,578 entitled “Implantable Device and Methods for Delivering Drugs and Other Substances to Treat Sinusitis and Other Disorders” filed on Aug. 4, 2004, 3) U.S. patent application Ser. No. 10/944,270 entitled “Apparatus and Methods for Dilating and Modifying Ostia of Paranasal Sinuses and Other Intranasal or Paranasal Structures” filed on Sep. 17, 2004 and 4) U.S. patent application Ser. No. 11/037,548 entitled “Devices, Systems and Methods For Treating Disorders of the Ear, Nose and Throat” filed Jan. 17, 2005, the entireties of each such parent application being expressly incorporated herein by reference.

FIELD OF THE INVENTION

[0002] The present invention relates generally to medical devices, systems and methods and more particularly to methods and devices for performing image guided interventional procedures to treat disorders of the paranasal sinuses, ears, nose or throat (ENT).

BACKGROUND OF THE INVENTION

[0003] A. Recent Advancements in the Treatment of ENT Disorders

[0004] New devices, systems and techniques are being developed for the treatment of sinusitis and other disorders of the ear, nose, throat and paranasal sinuses. For example, various catheters, guidewires and other devices useable to perform minimally invasive, minimally traumatic ear, nose and throat surgery have been described in U.S. patent application Ser. No. 10/829,917 entitled “Devices, Systems and Methods for Diagnosing and Treating Sinusitis and Other Disorders of the Ears, Nose and/or Throat,” Ser. No. 10/912,578 entitled “Implantable Device and Methods for Delivering Drugs and Other Substances to Treat Sinusitis and Other Disorders,” Ser. No. 10/944,270 entitled “Apparatus and Methods for Dilating and Modifying Ostia of Paranasal Sinuses and Other Intranasal or Paranasal Structures” and Ser. No. 11/037,548 entitled “Devices, Systems and Methods For Treating Disorders of the Ear, Nose and Throat.” Many of these new devices, systems and techniques are useable in conjunction with endoscopic, radiographic and/or electronic assistance to facilitate precise positioning and movement of catheters, guidewires and other devices within the ear, nose, throat and paranasal sinuses and to avoid undesirable trauma or damage to critical anatomical structures such as the eyes, facial nerves and brain.

[0005] For example, in one new procedure (referred to in this patent application as a “Flexible Transnasal Sinus Intervention” or FTSI), a dilation catheter (e.g., a balloon catheter

or other type of dilator) is advanced through the nose to a position within the ostium of a paranasal sinus or other location, without requiring removal or surgical alteration of other intranasal anatomical structures. The dilation catheter is then used to dilate the ostium or other anatomical structures to facilitate natural drainage from the sinus cavity. In some cases, a tubular guide may be initially inserted through the nose and advanced to a position near the sinus ostium and a guidewire may then be advanced through the tubular guide and into the affected paranasal sinus. The dilation catheter may then be advanced over the guidewire and through the tubular guide to a position where its dilator (e.g., balloon) is positioned within the sinus ostium. The dilator (e.g., balloon) is then expanded causing the ostium to dilate. In some cases, such dilation of the ostium may fracture, move or remodel bony structures that surround or are adjacent to the ostium. Optionally, in some procedures, irrigation solution and/or therapeutic agents may be infused through a lumen of the dilation catheter and/or other working devices (e.g., guidewires, catheters, cannula, tubes, dilators, balloons, substance injectors, needles, penetrators, cutters, debriders, microdebriders, hemostatic devices, cautery devices, cryosurgical devices, heaters, coolers, scopes, endoscopes, light guides, phototherapy devices, drills, rasps, saws, etc.) may be advanced through the tubular guide and/or over the guidewire to deliver other therapy to the sinus or adjacent tissues during the same procedure in which the FTSI is carried out. It is to be understood that, in FTSI procedures, structures and passage-ways other than sinus ostia may be dilated using the tools described above, tissue may be resected or ablated, bone may be restructured, drugs or drug delivery systems may be deployed, etc., as described in the documents incorporated here by reference. Thus, for the purposes of this application the term FTSI will generally used to refer broadly to all of those procedures, not just dilation of sinus ostia.

[0006] B. Prior Uses of Image Guided Surgery in the Treatment of ENT Disorders

[0007] Image guided surgery (IGS) procedures (sometimes referred to as “computer assisted surgery”) were first developed for use in neurosurgery and have now been adapted for use in certain ENT surgeries, including sinus surgeries. See, Kingdom T. T., Orlandi R. R., *Image-Guided Surgery of the Sinuses: Current Technology and Applications*, Otolaryngol. Clin. North Am. 37(2):381-400 (April 2004). Generally speaking, in a typical IGS procedure, a digital tomographic scan (e.g., a CT or MRI scan) of the operative field (e.g., the nasal cavities and paranasal sinuses) is obtained prior to surgery. A specially programmed computer is then used to convert the digital tomographic scan data into a digital map. During surgery, sensors mounted on the surgical instruments send data to the computer indicating the position of each surgical instrument. The computer correlates the data received from the instrument-mounted sensors with the digital map that was created from the preoperative tomographic scan. One or more image(s) is/are then displayed on a monitor showing the tomographic scan along with an indicator (e.g., cross hairs or an illuminated dot) of the real time position of each surgical instrument. In this manner, the surgeon is able to view the precise position of each sensor-equipped instrument relative to the surrounding anatomical structures shown on the tomographic scan.

[0008] A typical IGS surgery system of the prior art includes a) a computer work station, b) a video monitor, c) one or more surgical instruments having sensors mounted

thereon, d) a localizer and e) a sensor tracking system. The sensor(s) mounted on the surgical instruments and the corresponding tracing system may be optical, electromagnetic or electromechanical. The localizer functions to localize or “register” the preoperative tomographic image data with the real time physical positioning of the patient’s body during surgery. The sensor tracking system serves to track the position of each sensor equipped surgical instrument during the surgery and to communicate such information to the computer workstation.

[0009] In IGS systems that employ optical sensors/tracking systems, optical navigation elements (e.g., infrared light emitting LEDs or passive markers) are placed on the surgical instruments and on a localizer frame worn by the patient. Camera(s) is/are positioned to receive light emitted or reflected from the navigation elements. One example of an optical IGS system that is useable in ENT and sinus surgery is the LandmarX Evolution® ENT II Image Guidance System available from Medtronic Xomed Surgical Products, Inc., Jacksonville, Fla. Other optical IGS systems useable in ENT surgery include the VectorVision® system and Kolibri® system available from BrainLAB, Inc., Westchester, Ill. In the VectorVision® system and Kolibri® systems a sensor assembly, known as a STARLINK™ Universal Instrument Adapter, is attached to a portion of an instrument that remains outside of the patient’s body. A plurality of passive markers in the nature of reflective members is positioned at spaced apart locations on the navigation element assembly. An infrared light source and cameras are positioned to receive light reflected from the passive markers located on the navigation element assembly. A computer then receives input from the cameras and uses software tracking algorithms to determine the real time position of the instrument within the subject’s body based on the relative spatial positions of the passive markers. The instrument’s current position is then displayed on a monitor along with stored tomographic images, thereby enabling the operator to monitor the position and movement of the instrument relative to anatomical structures of interest.

[0010] In IGS systems that employ electromagnetic sensors/tracking systems, radiofrequency electromagnetic sensors (e.g., electromagnetic coils) are placed on the surgical instruments and on a localizer frame worn by the patient. A transmitter is positioned near the operative field. The transmitter transmits signals that are received by the instrument-mounted sensors. The tracking system detects variations in the electromagnetic field caused by the movement of the instrument-mounted sensors relative to the transmitter. Examples of commercially available electromagnetic IGS systems that have been used in ENT and sinus surgery include the ENTrak Plus™ and InstaTrak ENT™ systems available from GE Medical Systems, Salt Lake City, Utah. Other examples of electromagnetic image guidance systems that may be modified for use in accordance with the present invention include but are not limited to those available from Surgical Navigation Technologies, Inc., Louisville, Colo., Biosense-Webster, Inc., Diamond Bar, Calif. and Calypso Medical Technologies, Inc., Seattle, Wash.

[0011] In IGS systems that employ electromechanical sensors/tracking systems, a multi-jointed articulating mechanical arm is attached to the surgical instrument and sensors to measure movements of the joints. The computer determines the location of the instrument based on signals received from the sensors. Electromechanical systems have not been widely used in ENT or sinus surgery.

[0012] In any IGS system used in sinus surgery or other ENT applications, it is imperative that the localization system provide accurate “registration.” Registration is the process of matching two sets of data (i.e., the preoperative tomographic scan data and the intraoperative patient body position data) so that the image displayed on the monitor will accurately show the position(s) of the surgical instrument(s) relative to the locations of anatomical structures shown on the tomographic scan. A number of different registration strategies have been used, including intrinsic strategies as well as extrinsic strategies.

[0013] The registration strategy most widely used in sinus surgery and other ENT procedures is an intrinsic registration strategy known as anatomical fiducial registration. A number of fiducial markers are placed at specific anatomical locations on the patient’s body during the preoperative tomographic scan and during the surgical procedure. These fiducial markers are typically positioned on the patient’s head or face at locations that correspond to specific anatomical landmarks within the ears, nose and/or throat. The fiducial markers may be mounted on a head set or frame that is worn by the patient or the fiducial markers may be affixed directly to the patient’s body (e.g., by adhesive attachment to the skin, anchoring into bone, etc.).

[0014] Once the registration process has been completed, the sinus surgery or other ENT procedure is performed. To correlate head position with the tracking system, the fiducial markers must remain in fixed position on or in the patient’s body until after the surgery has been completed. Unlike neurosurgical procedures that require the patient’s head to be fixed in a rigid stereotactic frame, IGS systems that use fiducial markers mounted on or in the patient’s body allow for free movement and repositioning of the patient’s head during surgery.

[0015] When applied to functional endoscopic sinus surgery (FESS) the use of image guidance systems allows the surgeon to achieve more precise movement and positioning of the surgical instruments than can be achieved by viewing through an endoscope alone. This is so because a typical endoscopic image is a spatially limited, two dimensional, line-of-sight view. The use of image guidance systems provides a real time, three dimensional view of all of the anatomy surrounding the operative field, not just that which is actually visible in the spatially limited, two dimensional, direct line-of-sight endoscopic view.

[0016] One shortcoming of the prior art IGS systems used in sinus surgery and other ENT procedures is that the sensors have been mounted on proximal portions of the instruments (e.g., on the handpiece of the instrument) such that the sensors remain outside of the patient’s body during the surgical procedure. Because these prior art surgical instruments were of rigid, pre-shaped construction, the proximally mounted sensors could be used to accurately indicate to real time position of the distal tip of the instrument. However, in the new FTSI procedures and other new ENT procedures that use flexible and/or malleable catheters and instruments, it is no longer suitable to mount the sensors on proximal portions of the surgical instruments such that the sensors remain outside of the body. Rather, it will be necessary to mount or integrate the sensors at the distal tips of the instruments and/or at other locations on portions of the instruments that are actually inserted into the patient’s body, thereby allowing for flexibility or malleability of the instrument shaft.

[0017] The present invention provides new sensor-equipped devices that are useable to perform image guided FTSI procedures as well as a variety of other image guided ENT procedures. Additionally, the present invention provides improvements and modifications to the prior art IGS systems and methods to facilitate the performance of image guided FTSI and other image ENT procedures with minimal or less iatrogenic trauma to and/or alteration of anatomical structures that are not involved in the disorder being treated.

SUMMARY OF THE INVENTION

[0018] The present invention generally provides methods, systems and devices for performing image guided FTSI procedures as well as other image guided procedures for the treatment of sinusitis and other disorders of the paranasal sinuses, ears, nose and/or throat.

[0019] In accordance with the invention, there is provided a method and system for performing an image guided treatment procedure to treat a disease or disorder of an ear, nose, throat or a paranasal sinus in a human or animal subject. In this method and system, a working device (e.g., guidewires, catheters, cannula, tubes, dilators, balloons, substance injectors, needles, penetrators, cutters, debriders, microdebriders, hemostatic devices, cautery devices, cryosurgical devices, heaters, coolers, scopes, endoscopes, light guides, phototherapy devices, drills, rasps, saws, etc.) is inserted into an ear, nose, throat or paranasal sinus of the subject and used to carry out or facilitate at least a portion of the treatment procedure. A sensor is positioned on or in the portion of the working device that becomes inserted into the ear, nose, throat or paranasal sinus of the subject. An image guidance system is used to determine the location of the sensor when the sensor is positioned within an ear, nose, throat or paranasal sinus of the subject, thereby providing a real time indication of the positioning and movement of the working device during the treatment procedure. In some applications, a pre-operative tomographic scan (e.g., a CT scan, MRI scan, PET scan, 3 dimensional fluoroscopy such as FluoroCT, etc.) may be obtained and the image guidance system may be programmed to display the tomographic images on a video monitor along with a real time indication (e.g., cross hairs, an illuminated dot, etc.) of the location of the working device relative to the anatomical structures shown on the tomographic image. In some embodiments, an endoscope or intranasal camera may additionally be used to provide a direct line-of-sight video image through the nasal cavity. Such direct line-of-sight video image may be displayed on a separate monitor or may be integrated with the tomographic image data to provide a single monitor display combining 1) the real time line-of-sight video image, 2) indicia (e.g., dotted lines) depicting anatomical structures that are hidden from view on the real time line-of-sight video image and 3) indicia of instrument position provided by the image guidance system. In some applications, the indicia of instrument position may consist of a single indicator (e.g., cross hairs or a dot) indicating the current position of the working device within the subject's body. In other applications, the indicia of instrument position may consist of a series of marks (e.g., a sharp dot followed by a series of phantom dots) indicating the path of prior or future advancement or movement of the working device. Also, in some applications, the working device may optionally include a rotation indicator (e.g., an accelerometer) and the image guidance system may be further pro-

grammed to sense and indicate the rotational orientation of the working device within the subject's body.

[0020] Further in accordance with the invention, there are provided sensor-equipped working devices (e.g., guidewires, catheters, cannula, tubes, dilators, balloons, substance injectors, needles, penetrators, cutters, debriders, microdebriders, hemostatic devices, cautery devices, cryosurgical devices, heaters, coolers, scopes, endoscopes, light guides, phototherapy devices, drills, rasps, saws, etc.) useable to perform image guided FTSI procedures or other image guided ENT procedures. These image guided working devices of the present invention generally comprise an elongate shaft that is insertable through the nose to a location within a paranasal sinus, ear, nose or throat of the subject and one or more sensor(s) is/are positioned on or in the device at a location that becomes inserted into the subject's body during the procedure. In some embodiments, a sensor may be located at the distal tip of the device. Additionally or alternatively, sensor(s) may be located at other locations on the shaft of the device, such as at the location of a particular working element (e.g., a dilator, balloon, substance injector, needle, penetrator, cutter, debrider, microdebrider, hemostatic device, cautery device, cryosurgical device, heater, cooler, scope, lense, port, endoscope, light guide, phototherapy device, drill, rasp, saw, etc.). In some embodiments, the shaft of the working device proximal to the sensor(s) may be flexible or malleable. Such flexibility or malleability may allow the working device to be advanced through tortuous regions of the intra nasal anatomy and/or to be positioned behind obstructive anatomical structure(s) (e.g., behind the uncinate process) without traumatizing or requiring removal or surgical modification of the obstructive anatomical structure(s).

[0021] Still further in accordance with the present invention, there is provided a system of working devices specifically useable to perform an image guided FTSI procedure. Such system generally comprises a flexible guidewire that is advanceable into the ostium of a paranasal sinus and a dilation catheter that is advanceable over the guidewire and useable to dilate the ostium of the paranasal sinus. A sensor is located on a portion of the guidewire and/or dilation catheter that becomes positioned within the subject's body. The sensor communicates with the image guidance system to provide real time indicia of the position of the guidewire and/or dilation catheter such that the operator may precisely position the dilator within the desired sinus ostium without the need for obtaining direct line-of-sight endoscope view of that sinus ostium. Optionally, the system may additionally comprise a tubular guide through which the guidewire and/or dilation catheter may be advanced. The tubular guide may be rigid, flexible or malleable and may be specifically configured to be advanced through the nose to a position within or near the ostium of the affected paranasal sinus.

[0022] Still further in accordance with the present invention, there are provided fiducial marker devices that may be precisely and reproducibly positioned within the mouth of a human subject. In some embodiments, these fiducial marker devices may incorporate brackets, projection of other configurational attributes for mounting of a transmitter useable in conjunction with an electromagnetic image guidance system.

[0023] Still further in accordance with the present invention there are provided methods and systems for image guided procedures wherein a single sensor is mounted on a working device that is inserted into the body (e.g., into a paranasal sinus, and a plurality of transmitters are positioned outside of

the subject's body such that the device-mounted sensor will receive signals from at least 3 transmitters, thereby enabling a computer within the image guidance system to compute (e.g., triangulate) the three dimensional position of the sensor within the subject's body.

[0024] Still further in accordance with the present invention there is provided a system that is useable to perform a procedure in which a working device is inserted to a position within an ear, nose, throat or paranasal sinus of a human or animal subject. In general, such system comprises a) a working device that has a proximal end and a distal end, said working device being insertable into an ear, nose, throat or paranasal sinus of a human or animal subject and useable to facilitate performance of a diagnostic or therapeutic procedure; b) an extender that is attachable to the proximal end of the working device; c) a marker assembly that is attachable to or part of the extender, said marker assembly comprising a plurality of active or passive markers; and d) an image guidance system that is adapted to receive signals from the sensors and to determine, on the basis of said signals, the current position of the working device within the subject's body. In some embodiments, the working device may have a lumen through which a second working device may be inserted or through which a fluid or substance may be infused. In such embodiments, the extender may also have a lumen that becomes substantially continuous with the working device lumen to facilitate delivery of such second working device or substance. In some embodiments, the marker assembly may be attachable to and detachable from the extender by way of a clamp or other connector apparatus. Still further in accordance with the invention, there is provided a method for image guided performance of a treatment procedure to treat a disease or disorder of an ear, nose, throat or a paranasal sinus in a human or animal subject. Such method generally comprises the steps of a) providing a working device that is useable to carry out or facilitate at least a portion of said treatment procedure, said working device having a distal end that becomes inserted into the subject's body and a proximal end that remains outside of the subject's body; b) providing an extension member that is attachable to the proximal end of the working device; c) providing a marker assembly that comprises a plurality of markers, said marker assembly being attachable to the extension member; c) providing an image guidance system that is useable to determine the location of the working device within the ear, nose, throat or paranasal sinus of the subject on the basis of signals received from the markers of the marker assembly; d) attaching the extension member to the proximal end of the working device; e) attaching the marker assembly to the extension member; g) inserting the distal end of the working device into the subject's body; and h) using the image guidance system to detect the position of the working device within the subject's body on the basis of signals received from the markers of the marker assembly.

[0025] Further aspects, details and embodiments of the present invention will be understood by those of skill in the art upon reading the following detailed description of the invention and the accompanying drawings.

BRIEF DESCRIPTION OF THE DRAWINGS

[0026] FIG. 1 is a side view of a sensor-equipped guidewire of the present invention.

[0027] FIG. 1A is an enlarged cut-away view of the distal end of the sensor-equipped guidewire of FIG. 1.

[0028] FIG. 2A is a perspective view of a sensor-equipped guide tube of the present invention.

[0029] FIG. 2B is a perspective view of another sensor-equipped guide tube of the present invention.

[0030] FIG. 3 is a schematic perspective view of a sensor-equipped working device useable to perform a therapeutic or diagnostic procedure within an ear, nose, throat or paranasal sinus.

[0031] FIG. 4 is a perspective view of a sensor-equipped dilation catheter of the present invention.

[0032] FIG. 4A is a partial cut away view of a first embodiment of a sensor equipped balloon dilation catheter of the present invention.

[0033] FIG. 4B is a cross sectional view through line 4B-4B of FIG. 4A.

[0034] FIG. 4C is a partial cut away view of a second embodiment of a sensor equipped balloon dilation catheter of the present invention.

[0035] FIG. 4D is a cross sectional view through line 4D-4D of FIG. 4C.

[0036] FIG. 4E is a partial cut away view of a third embodiment of a sensor equipped balloon dilation catheter of the present invention.

[0037] FIG. 4F is a cross sectional view through line 4F-4F of FIG. 4E.

[0038] FIG. 4G is a partial cut away view of a fourth embodiment of a sensor equipped balloon dilation catheter of the present invention.

[0039] FIG. 4H is a cross sectional view through line 4H-4H of FIG. 4G.

[0040] FIG. 4I is a partial cut away view of a fifth embodiment of a sensor equipped balloon dilation catheter of the present invention.

[0041] FIG. 4J is a cross sectional view through line 4J-4J of FIG. 4I.

[0042] FIG. 5 is a perspective view of a sensor-equipped sub-selective sheath of the present invention.

[0043] FIG. 5A is a cross sectional view through line 5A-5A of FIG. 5.

[0044] FIG. 6 is a side view of a sensor equipped penetrator of the present invention.

[0045] FIG. 7A shows a human subject undergoing a preoperative tomographic scan while wearing a head frame having fiducial anatomical markers thereon.

[0046] FIG. 7B is a schematic showing of data from the preoperative tomographic scan being loaded into the computer workstation of the image guidance system in accordance with this invention.

[0047] FIG. 7C shows an example of the image guidance system being used to provide a single image display (which may or may not incorporate superimposed data or indicia from multiple sources).

[0048] FIG. 7D an example of the image guidance system being used to provide separate displays of multiple images.

[0049] FIG. 7E shows the human subject positioned on the operating table and wearing the head frame having fiducial anatomical markers and a transmitter thereon.

[0050] FIG. 8 is a schematic depiction of an electromagnetic field having a sensor equipped working device of the present invention positioned therein.

[0051] FIG. 8A is a perspective view of one embodiment of a localizer apparatus mountable transmitter having one or more transmitter locations.

[0052] FIG. 8B is a perspective view of another embodiment of a localizer apparatus mountable transmitter having three transmitter locations.

[0053] FIG. 8C is a perspective view of another embodiment of a localizer apparatus mountable transmitter having three transmitter locations.

[0054] FIG. 9 shows the human subject positioned on the operating table during performance of an image guided interventional procedures using sensor equipped device(s) of the present invention.

[0055] FIG. 9A is a schematic showing of a video monitor displaying indicia of the path of advancement or movement of a sensor equipped working device in accordance with the present invention.

[0056] FIG. 10A shows a first orthogonal view of an anatomical image with indicators of the current position of the distal tip of a working device and indicia of the path of advancement of that working device, as seen on a video monitor screen during performance of a procedure according to this invention.

[0057] FIG. 10B shows a second orthogonal view of the procedure shown in FIG. 10A as viewed on a separate video monitor screen during performance of a procedure according to this invention.

[0058] FIGS. 11A-11C show examples of direct line-of-sight endoscopic images with superimposed indicia indicating the positions of anatomical structure(s) and/or apparatus that are hidden from view on the line-of-sight endoscopic images, as viewed on video monitors during performance of procedures according to this invention.

[0059] FIG. 12 shows a sensor-equipped working device of the present invention that is additionally equipped with a rotation sensor to indicate the rotational orientation of the device while it is positioned within a subject's body.

[0060] FIGS. 13A and 13B are schematic showings of examples of anatomical images viewed on a video monitor with indicia of the current position and prior path of advancement of an image guided working device shown in relation to a) adjacent anatomical structures and b) "keep in" and/or "keep out" zones that have been delineated to assist the operator in safely and correctly performing the procedure.

[0061] FIG. 14A is a top perspective view of a first embodiment of a fiducial marker mouthpiece according to the present invention.

[0062] FIG. 14B is a side perspective view of the fiducial marker mouthpiece of FIG. 14 A.

[0063] FIG. 15A is a top perspective view of a second embodiment of a fiducial marker mouthpiece according to the present invention.

[0064] FIG. 15B is a side perspective view of the fiducial marker mouthpiece of FIG. 15 A.

[0065] FIG. 15C is a front view of the mouth of a human subject having the fiducial marker mouthpiece of FIGS. 15A and 15B in its operative position.

[0066] FIG. 16 is a partial cut-away side view of a sensor equipped guidewire of the present invention attached to a cable/connector assembly of the present invention.

[0067] FIG. 17 is a partial cut-away side view of a sensor equipped working device of the present invention having a cable/connector assembly of the present invention attached thereto.

[0068] FIG. 18 is an exploded view of a system of the present invention that includes a tubular guide working device, an extension that is attachable to the proximal end of

the tubular guide working device and a navigation elements assembly that is attachable to the extender to facilitate tracking of the working device by an IGS system.

[0069] FIG. 19 is a fully assembled view of the device of FIG. 18 along with an IGS system useable therewith.

DETAILED DESCRIPTION

[0070] The following detailed description, the drawings and the above-set-forth Brief Description of the Drawings are intended to describe some, but not necessarily all, examples or embodiments of the invention. The contents of this detailed description, the accompanying drawings and the above-set-forth brief descriptions of the drawings do not limit the scope of the invention or the scope of the following claims, in any way.

[0071] In this invention, various types of working devices are equipped with sensors and are used to perform interventional procedures within the paranasal sinuses, ears, noses and throats of human or animal subjects, while an image guidance system is used to track the location of the sensor(s) and, hence, the location(s) of the working device(s). FIGS. 1-6 and 11 show examples of sensor equipped working devices of the present invention. FIGS. 7A-17 show various components and operational aspects of an image guidance system of the present invention and its use in conjunction with the sensor equipped working devices of the present invention.

[0072] FIGS. 1 and 1A show a sensor equipped guidewire 10 that may be inserted through a nostril (with or without a guide tube or guide catheter) and advanced to a desired location within a paranasal sinus, ear, nose or throat. This sensor-equipped guidewire 10 comprises an elongate flexible body 12 having a proximal end PE and a distal end DE. As shown in the cut-away view of FIG. 1A, the elongate body 12 comprises a core member 19 which may be solid or tubular. In the particular example shown, the core member 19 is tubular and comprises stainless steel hypotube. Optionally, an outer member 18 such as a helical strand or wire may be wound or otherwise disposed about the core member 19, as is well known in the art of guidewire manufacturing. In the particular example shown, a distal tip member 15 formed of electrically insulating material (e.g., plastic) is received within and/or affixed to the distal end of the core member 19 by any appropriate means such as adhesive (e.g., epoxy), mechanical innerlocking, frictional fit, etc. An electromagnetic sensor 16 (e.g., an electromagnetic coil) is disposed (e.g., coiled) about the mid-region of the non-conductive distal tip member 15. Optionally, an electrically insulating cylindrical cover 17 (e.g. a plastic sheath, plastic shrink wrap, etc) may be disposed about the electromagnetic sensor 16. The outer surface of such cover 17, if present, may be substantially flush with the adjacent outer surface of the outer member 18, if present, as shown in FIG. 1A. In embodiments where the core member 19 is hollow (e.g., hypotube) sensor leads 14 may extend from the electromagnetic sensor coil 16, through the lumen of the core member 19 and to or out of the proximal end PE of the guidewire 10. In some embodiments, a connector 21 (e.g., a jack) located on the proximal end PE of the guidewire 10 may be configured to connect to a corresponding connector 27 (e.g., a plug) located on one end of a cable 25. A connector 23 on the other end of the cable 25 is then connectable to an image guidance system that is programmed for use in combination with such guidewire, as described more fully herebelow. In some embodiments, the guidewire's proximal connector 21 may be connected to another types of cable/

connector assembly **400** as shown in FIGS. **16** and **17** and described herebelow. Also, in some embodiments of devices of this invention, the sensor **16** may be in wireless communication with an image guidance system, as explained more fully herebelow.

[0073] It will also be appreciated that the outer helical wire wrap **18** may be formed of wire, a plastic strand, a helically cut metal or plastic tube, or any other suitable material. It will also be appreciated that the guidewire **10** may be constructed such that at least a distal portion of the outer member **18** or other outer material (e.g., helically cut tube) may be made of substantially nonferromagnetic material and may extend over the sensor **16** such that the sensor is disposed within a substantially nonferromagnetic portion of the outer member **18**. The sensor leads **14** may then extend through the outer member **18**.

[0074] Furthermore, it is to be appreciated that, in this guidewire **10** or any other sensor equipped device of the present invention, the sensor **16** need not necessarily be longitudinally aligned with or disposed about the longitudinal axis of the device. Rather, the sensor may be disposed transversely within the device or in any other suitable attitude, position or alignment. For example, in a guidewire, catheter or other device that has a lumen or cavity formed therein, a crossmember may extend transversely across such lumen or cavity and the sensor **16** may be disposed about such crossmember (e.g., an electromagnetic coil may be wound about the cross member). Such construction may allow for better selectivity and control of the magnetic permeability of the material lying under and/or over the sensor **16** and may allow for a more robust design and construction of certain devices.

[0075] Examples of commercially available image guidance systems that may be modified and programmed for use in connection with this sensor equipped guidewire **10**, as well as the other sensor equipped working devices described in this patent application, include the ENTrak Plus™ and InstaTrak ENT™ systems available from GE Medical Systems, Salt Lake City, Utah as well as systems available from Surgical Navigation Technologies, Inc., Louisville, Colo., Biosense-Webster, Inc., Diamond Bar, Calif. and Calypso Medical Technologies, Inc., Seattle, Wash.

[0076] As described herebelow, it will often be desirable to advance catheters or other devices over the guidewire **10** after the guidewire **10** has been inserted into the subject's body. Thus, the guidewire body **12** and any proximal connector **21** may be small enough in diameter to allow the desired catheter (s) and/or other device(s) to be advanced over the guidewire body **12** and any proximal connector **21**.

[0077] FIGS. **2A** and **2B** show examples of sensor equipped tubular guides **20a**, **20b** that may be inserted through a nostril (with or without a guidewire) and advanced to a desired location within a paranasal sinus, ear, nose or throat. All of portions of tubular guides of the present invention may be rigid, flexible or malleable. In the particular examples shown in FIGS. **2A** and **2B**, the tubular guides **20a**, **20b** are substantially rigid and preformed to a specific shape to facilitate advancement of the tubular guide **20a** or **20b** to locations that are immediately adjacent to the ostia of paranasal sinuses such that working devices such as dilation catheters and the like may be advanced through the tubular guide **20a** or **20b** and into or through the adjacent sinus ostium.

[0078] Specifically, FIG. **2A** shows an example of a tubular guide **20a** that is configured for use in accessing the ostium of a maxillary sinus of a human subject. This tubular guide **20a**

comprises a substantially straight proximal portion **22a** and a curved distal portion **24a**. A Luer hub **28a** is mounted on the proximal end PE of the proximal portion **20a**. A sensor **16**, such as an n electromagnetic sensor coil, is positioned on the curved distal portion **24a**. Wire leads **14** may extend from the electromagnetic sensor coil **16**, though the proximal portion **22a** and out of the proximal end PE of the tubular guide **20a**, as shown, for attachment of the tubular guide **20a** to an image guidance system that is programmed for use in combination with such guidewire as described more fully herebelow. Although various types of construction and materials may be used, in this particular example, the proximal portion **22a** comprises stainless steel hypotube of approximately 0.040 inch to approximately 0.200 inch outer diameter. It will be appreciated that in embodiments where stainless steel or other metal is used, such metal will be separated from the sensor **16** by insulating material(s) and/or sufficient distance to avoid any affect that the metal may have on the accuracy or function of the sensor **16**. A plastic tube formed of rigid plastic (e.g., pebax, polyurethane, etc) is advanced through the lumen of the hypotube such that a portion of the plastic tube protrudes out of and beyond the distal end of the hypotube. This protruding portion of the plastic tube is then plastically deformed (e.g., thermally formed) to the desired curvature, thereby forming the curved distal portion **24a** of the tubular guide **20a**. In this example, the sensor **16** comprises a coil that is wound about or positioned about the outer surface of the curved distal portion **24a** of the tube. Optionally, a plastic film or other electrically insulating cover (e.g, an outer skin) may be heat shrunk or otherwise disposed and secured about the electromagnetic sensor **16** to provide a smooth outer surface in the area where the electromagnetic sensor **16** is mounted. The electromagnetic sensor **16** may be mounted at or near the distal tip of the tubular guide **20a** to permit the associated image guidance system to monitor the real time position of the distal tip of the guide **20a**. Wire leads **14** may extend from the electromagnetic sensor **16**, through or along the distal portion **24a**, through or along the proximal portion and out of the proximal end PE of the tubular guide **20a**, as shown. In this regard, the plastic tube that extends through the metal hypotube and protrudes therefrom to form the curved distal portion **24a** may have a large working lumen as well as one or two additional lumens through which the wire leads **14** may pass. Alternatively, the wire leads **14** may pass along the outer surface of the distal portion **24a**, the through the lumen of the hypotube, between the outer surface of the inner plastic tube and inner surface of the outer hypotube. In this particular example, the distal portion **24a** is substantially rigid and is preformed to a curve of from approximately 70 degrees through approximately 135 degrees, so as to be useable for accessing the ostium of a maxillary sinus without requiring substantial cutting or surgical modification of the uncinate process or other normal anatomical structures within the nose. Alternatively, it will be appreciated that the distal portion **24a** may be malleable (e.g., a malleable metal, polymer or metal-polymer composite) so that the operator may shape the distal portion **24a** as desired, depending on the particular sinus ostium or other location to be accessed, anatomical irregularities of the subject, etc. So long as the electromagnetic sensor coil **16** is located distal to any curve(s) introduced in the malleable distal segment, the introduction of such custom made curve(s) will not require any recalibration or otherwise hamper the ability of the image guidance system to sense the position of the distal end of the tubular guide **20a**. In

operation, this tubular guide **20a** is inserted through the subject's nostril, either alone, over a previously inserted guidewire or with a guidewire pre-inserted into the lumen of the tubular guide **20a**. The tubular guide **20a** is then advanced through the medial meatus and rotated to cause the curve of the distal portion **24a** to pass over the uncinate process such that the open distal end DE of the tubular guide **20a** is positioned adjacent to and in substantial alignment with the ostium of the maxillary sinus.

[0079] The tubular guide **20b** shown in FIG. 2B may be constructed and used in the same manner as the tubular guide **20a** of FIG. 2A except that the curved distal portion **24b** has a less severe curvature than the distal portion of the **24a** of the guide shown in FIG. 2A. In this particular example, the distal portion **24b** is substantially rigid and is preformed to a curve of from approximately 30 degrees through approximately 90 degrees, thereby being useable for accessing the ostia of frontal sinuses.

[0080] It is to be appreciated that the particular curvatures and shapes of the tubular guides **20a**, **20b** shown in FIGS. 2A and 2B are merely examples of the many shapes and configurations in which tubular guides of the present invention may be configured to access specific locations within the nose, paranasal sinuses, Eustacian tubes, etc. Additionally, it is to be appreciated that any of the guidewires **10**, tubular guides **20a**, **20b** or other working devices **30** of this invention may be steerable, bendable, malleable or capable of being articulated. FIG. 3 shows a generic example of a sensor-equipped working device **30** of the present invention. This device **30** comprises an elongate shaft **32**, a sensor **16**, a working element **36** and wires **14** that extend from the sensor **16** through the shaft **32** and out of the proximal end PE of the device **30**. In some embodiments, the outer diameter of the working device **30** may be less than the inner diameter of a sensor-equipped tubular guide **20a** or **20b** or other tubular guide such that the working device **30** may be advanced through a tubular guide to a desired location where treatment is to be applied. Additionally or alternatively, the working device **30** may have a guidewire lumen extending through or adjacent to the shaft **32** such that the working device **30** may be advanced over a sensor-equipped guidewire **10** or other guide member to a desired location where the treatment is to be applied. In this example, the sensor **16** comprises a coil that is wound about or positioned about the outer surface of shaft **32** a known distance from the distal end DE of the device **30**. Provided that any bending, curving or flexing of the shaft **32** occurs proximal to the sensor **16**, the spatial relationship of the sensor **16** to the distal end DE will remain constant and, thus, the position of the distal end DE of the device **30** may be determined and displayed on a video screen on the basis of the sensed location of the sensor **16**. In some embodiments, one or more sensors may be positioned in known spatial relation to the working element so as to provide the ability to determine and display the real time location of the working element on the basis of the sensed location of the sensor(s) **16**. In embodiments where the sensor comprises a wire coil, such coil may be positioned within or wound about the outer surface of the elongate shaft **32**. Optionally, a plastic film or other electrically insulating cover (e.g., an outer skin) may be heat shrunk or otherwise disposed and secured about the sensor **16** to provide a smooth outer surface in the area where the sensor **16** is mounted. Wire leads **14** may extend from the sensor **16**, through the shaft **32** to facilitate connection of the sensor **16** to an image guidance console (e.g., a computer workstation)

as described herein. Alternatively, the wire leads **14** may pass along the outer surface of the shaft **32** and may be secured by adhesive, a surrounding wrap, sheath or skin, etc. These wire leads **14** or the sensor **16** itself may be connected directly, indirectly through an intervening apparatus (e.g., a cable, self-calibrating instrument system or other intervening apparatus) or by wireless connection to the console **76** and/or computer **78**. In applications where the sensor **16** or its leads **14** are connected to the console **76** and/or computer **78** by way of a self-calibrating instrument system, such self-calibrating instrument system may comprise a sensor-equipped distal instrument attached to a proximal handpiece. The instrument system would be initially calibrated by touching the sensor-equipped distal instrument to fiducial markers. Once the instrument system was calibrated, the sensor-equipped distal instrument could be exchanged for other sensor-equipped distal instruments without requiring the user to recalibrate the instrument system. Instead, the instrument system would self calibrate by means of the proximal handpiece reading calibration information embedded electronically in a tag on the distal instrument.

[0081] The working element **36** may be positioned at a location between the proximal end PE and distal end DE, as shown in the example of FIG. 3. Alternatively, the working element **36** may be positioned at or on the distal end DE of the device **30**, depending on the mode of action and intended use of the working element. The working element **36** may perform or facilitate any type of therapeutic or diagnostic function. Examples of working elements **36** that may be used include but are not limited to: dilators, balloons, substance injectors, needles, penetrators, cutters, debriders, microdebriders, hemostatic devices, cautery devices, cryosurgical devices, heaters, coolers, scopes, lenses, ports, endoscopes, light guides, phototherapy devices, drills, rasps, saws, etc. Some specific examples of working elements **36** and their uses in ENT procedures are described in U.S. patent application Ser. No. 10/829,917 entitled "Devices, Systems and Methods for Diagnosing and Treating Sinusitis and Other Disorders of the Ears, Nose and/or Throat," Ser. No. 10/912,578 entitled "Implantable Device and Methods for Delivering Drugs and Other Substances to Treat Sinusitis and Other Disorders," Ser. No. 10/944,270 entitled "Apparatus and Methods for Dilating and Modifying Ostia of Paranasal Sinuses and Other Intranasal or Paranasal Structures" and Ser. No. 11/037,548 entitled "Devices, Systems and Methods For Treating Disorders of the Ear, Nose and Throat," which are expressly incorporated herein by reference.

[0082] Optionally, any working device **30** of this invention, may include a guide member **37**, such as a flexible, malleable or rigid wire or other elongate member, that extends from the distal end DE of the device, as shown in phantom in FIG. 3. This guide member **37** may be tapered or nontapered. The guide member **37** will typically be smaller in diameter than the body **32** of the working device **30** such that the guide member may be easily advanced through an ostium of other anatomical opening, thereby facilitating or "guiding" placement of the body **32** of the device **30** in a position adjacent to that ostium or opening and/or thereby facilitating or guiding further advancement of the body **32** of the device **30** through that ostium or opening.

[0083] In systems used to perform FTSI procedures, a working device **30** wherein the working element **36** comprises a balloon or other dilator will be used to dilate the ostium of a paranasal sinus. FIGS. 4-4J show some specific

examples of sensor equipped working devices in the nature of dilation catheters (e.g., balloon catheters) for dilation of the ostia of paranasal sinuses or other anatomical or pathological structures.

[0084] FIGS. 4-4B show an embodiment of a sensor equipped dilation catheter 40a comprising a shaft 42 comprising a single, multi-lumen tube, a proximal Luer hub 48, a balloon 46, sensor(s) 16 and sensor leads 14. While any number of sensors 16 may be used, the example shown in FIGS. 4-4B incorporates two (2) sensors 16, wherein one sensor 16 is located near the proximal end of the balloon 46 and the other sensor 16 is located near the distal end of the balloon 46. A through lumen 94 extends from the bore of the proximal Luer hub 48, through the shaft 42 and terminates distally in a distal end opening. This through lumen 94 may be used for fluid infusion/aspiration and/or for guidewire passage. Lead lumens 98 also extend through the shaft 42 and the sensor leads 14 extend through such lead lumens 98. An inflation/deflation lumen 96 extends from a sidearm port 49 on the proximal hub 48, through the shaft 42 and terminates in an aperture 91 within the balloon 46 to facilitate inflation and deflation of the balloon 46. For applications intended to dilate the ostia of paranasal sinuses, the balloon will typically be formed of a relatively non-compliant material such as polyethylene terephthalate (PET) or nylon of a thickness and density that renders the balloon capable of withstanding inflation pressures of up to approximately 25 atmospheres. The balloon 46 may have a straight cylindrical side wall with tapered ends, as shown, and if the balloon 46 is so constructed, the sensors 16 may be positioned directly beneath the proximal and distal ends of the straight cylindrical midportion MP of the balloon 46 as seen in FIG. 4A. As explained more fully herebelow, this catheter 40 may be advanced to a position where the deflated balloon 46 is positioned within a stenotic ostium of a paranasal sinus with the distal sensor 16 on one side of the ostium and the proximal sensor 16 on the other side of the ostium. The balloon 46 may then be inflated one or more times to desired pressure(s) (e.g., typically pressures ranging from about 10 atmospheres through about 25 atmospheres) to dilate the stenotic ostium. Thereafter, the balloon 46 may be deflated and the dilation catheter 40 removed. FIGS. 4C and 4D show another way in which a sensor equipped dilation catheter 40b may be constructed. In this example, the catheter 40b differs from that shown in FIGS. 4-4B because its shaft 104 comprises an outer tube 100 and an inner tube 102. The inner tube 102 extends through the outer tube 100 and protrudes out of the distal end of the outer tube 100 by a fixed distance. The sensors 16 are mounted on the outer tube 100 at spaced apart locations such that one sensor 16 is directly beneath the proximal end of the straight walled midportion MP of the balloon 46 and the other sensor 16 is directly beneath the distal end of the straight walled midportion MP of the balloon 46. The outer tube 100 has a main through lumen 106 and two lead lumens 108 through which the sensor leads 14 extend. The inner tube 102 has a through lumen 103 which may be used as a guidewire lumen and/or an infusion/aspiration lumen or for other purposes. The outer diameter of the inner tube 102 is smaller than the inner diameter of the outer tube 100 such that a space exists to allow balloon inflation fluid to be infused into or removed from the balloon 46 through the lumen of the outer tube 100. This embodiment of the dilation catheter 40 shown in FIGS. 4C-4D may be positioned and used to dilate the ostium of a

paranasal sinus in the same manner as that described above with respect to the embodiment of FIGS. 4-4B.

[0085] FIGS. 4E and 4F show yet another way in which a sensor equipped dilation catheter 40c may be constructed. In this example, like the example shown in FIGS. 4C and 4D, the catheter 40c has a shaft 114 that comprises an outer tube 100a and an inner tube 102a, wherein the outer tube 100a terminates near the longitudinal midpoint of the balloon 46 and the inner tube 102a extends through the outer tube 100a and protrudes out of the distal end of the outer tube 100a by a fixed distance. In this embodiment of the catheter 40c, the proximal sensor 16 is positioned on the outer tube 100a at a location that is directly beneath the proximal end of the straight walled midportion MP of the balloon 46 and the other sensor 16 is positioned on the inner tube 102a at a location that is directly beneath the distal end of the straight walled midportion MP of the balloon 46. The outer tube 100a has a main through lumen 106a and one lead lumen 120 through which the sensor leads 14 from the proximal sensor 16 extend. The inner tube 102a has a through lumen 103a which may be used as a guidewire lumen and/or an infusion/aspiration lumen. The outer diameter of the inner tube 102a is smaller than the inner diameter of the lumen 106a of outer tube 100a such that a space exists to allow balloon inflation fluid to be infused into or removed from the balloon 46 through the lumen 106a of outer tube 100a.

[0086] In the example of FIGS. 4E and 4F, the sensor leads 14 from the distal sensor 16 extend along the outer surface of the inner tube 102a, as shown, and may be secured to the outer surface of the inner tube 102a by any suitable means such as adhesive, clips, bands, sheathing, shrink wrapping, etc. It is to be appreciated, however, that in any of the embodiments, any of the sensor leads 14 may extend outside of, within or through a lumen of any portion of the catheter shaft, as may be desirable or expedient for manufacturing or operative purposes and/or to minimize electrical interference and optimize signal transmission. For example, FIGS. 4G and 4H show another way in which a sensor equipped dilation catheter 40d may be constructed. In this example, like the example shown in FIGS. 4E and 4F, the catheter 40d has a shaft 126 that comprises an outer tube 100b and an inner tube 102b. The outer tube 100b terminates near the longitudinal midpoint of the balloon 46 and the inner tube 102b extends through the outer tube 100b and protrudes out of the distal end of the outer tube 100b by a fixed distance. Again, in this embodiment of the catheter 40d, the proximal sensor 16 is positioned on the outer tube 100b at a location that is directly beneath the proximal end of the straight walled midportion MP of the balloon 46 and the other sensor 16 is positioned on the inner tube 102b at a location that is directly beneath the distal end of the straight walled midportion MP of the balloon 46. The outer tube 100b has a main through lumen 106b and one lead lumen 126 through which the sensor leads 14 from the proximal sensor 16 extend. The inner tube 102b has a through lumen 103b which may be used as a guidewire lumen and/or an infusion/aspiration lumen. The outer diameter of the inner tube 102b is smaller than the inner diameter of the outer tube 100b such that a space exists to allow balloon inflation fluid to be infused into or removed from the balloon 46 through the lumen 106b of the outer tube 100b. In this embodiment, a second lead lumen 128 is formed in the wall of the inner tube 102b and the wire leads 14 from the distal sensor 16 extend through such second lead lumen 128, as shown.

[0087] FIGS. 4I and 4J show yet another way in which a sensor equipped dilation catheter 40e may be constructed. In this catheter 40e, the shaft 136 comprises an outer tube 100c that terminates within the proximal region of the balloon 46 and the inner tube 102c extends through the outer tube 100c such that it protrudes out of the distal end of the outer tube 100c by a fixed distance. In this embodiment, both the proximal and distal sensors 16 are positioned on the inner tube 102c. Specifically, the proximal sensor 16 is positioned on the inner tube 100c at a location that is directly beneath the proximal end of the straight walled midportion MP of the balloon 46 and a distal sensor 16 is positioned on the inner tube 102c at a location that is directly beneath the distal end of the straight walled midportion MP of the balloon 46. The outer tube 100c has a main through lumen 106c through which the inner tube 102c extends. The inner tube 102c has a through lumen 103c which may be used as a guidewire lumen and/or an infusion/aspiration lumen and two lead lumens 142, 144 through which the sensor leads 14 from the proximal and distal sensors 16 extend. The outer diameter of the inner tube 102c is smaller than the inner diameter of the lumen 106c of outer tube 100c such that a space exists to allow balloon inflation fluid to be infused into or removed from the balloon 46 through the lumen 106c of outer tube 100c.

[0088] Although the balloons 46 shown in FIGS. 4-4J are straight walled cylindrical balloons having tapered ends, it is to be appreciated that various other shapes and configurations of balloons may be employed in any embodiments of the dilation catheter 40. For example, one or more depressions or indentations (e.g., an annular depression or groove) may be formed in the midportion MP of each balloon to facilitate positioning of the balloon and seating of ostial tissue or other anatomical tissue within such depressions or indentations. Examples of balloons having such depressions or indentations are described in U.S. patent application Ser. Nos. 10/829,917, 10/944,270 and 11/037,548, which are expressly incorporated herein by reference.

[0089] It is to be appreciated that the specific examples shown in the drawings are merely examples. Indeed, the sensors 16 may be positioned at many other locations other than those shown in these examples. For example, in any sensor equipped dilation catheter 40, sensor(s) may be located in the center of the balloon 46 or other working element and/or elsewhere on or in the catheter shaft within the balloon 46 or other working element and/or distal to the balloon 46 or other working element and/or proximal to the balloon 46 or other dilator and/or within the wall(s) of the balloon 46 or other dilator.

[0090] Also, in any of the working devices having lumen(s) the shaft of the device (e.g., the catheter body) need not be of coaxial (e.g., tube within a tube) design, but alternatively may be a single catheter body having a plurality of lumens. For example, in the case of a balloon dilation catheter, a catheter shaft having four lumens may be used. One lumen may serve as a guidewire/working lumen, one lumen may serve as a balloon 46 inflation/deflation lumen and the other two lumens may serve as passageways for the sensor leads 14. Also, as stated, in any of the sensor equipped devices 10, 20, 30, 40 a fixed guide tip and/or sensor 16 may be located at the distal end DE of the device.

[0091] Also, in any embodiment of a sensor equipped dilation catheter 40, the balloon 46 may be replaced by other types of dilators or expandable structures, such as expandable mesh cages and the like.

[0092] Also, in any embodiment of a sensor equipped dilation catheter 40, the balloon 46 or other dilator may be coated, textured, equipped with injection ports or otherwise equipped and/or constructed to deliver additional treatment(s) in addition to the primary anatomical dilation. For example, the balloon 46 may be coated with or may comprise a drug or any other substance (e.g., a hemostatic agent or a substance that deters scarring or adhesion formation) that will transfer onto or into the tissue contacted by the balloon. Examples of balloons having such additional treatment delivering capabilities are described in U.S. patent application Ser. Nos. 10/912,578 and 11/037,548, which are expressly incorporated herein by reference.

[0093] Additionally, in some embodiments of sensor equipped dilation catheter 40, a stent or other radially expandable implantable device may be mounted on the exterior of the balloon 46 or other dilator such that, when the balloon 46 is inflated (or when any other type of dilator is expanded) the stent or other radially expandable implantable device will be expanded and will remain within the body after the balloon has been deflated (or the other type of dilator contracted) and the dilation catheter 40 removed. Examples of stents and other radially expandable implantable devices that may be used in conjunction with these sensor equipped dilation catheters 40 are described in U.S. patent application Ser. Nos. 10/829,917; 10/912,578; 10/944,270 and 11/037,548, which are expressly incorporated herein by reference.

[0094] In some applications, it may be desirable to utilize a sensor equipped subselective sheath 50, such as that shown in FIGS. 5 and 5A. The sheath 50 shown in FIGS. 5 and 5A comprises an elongate tubular body 52 having a Luer hub 54 on its proximal end PE and a sensor 16, such as an electromagnetic coil located at some desired location, such as at or near the distal end DE of the tubular body 52. A main lumen 216 extends through the tubular body 52 in communication and direct alignment with the bore of the Luer hub 54. A separate lead lumen 56 also extends through the tubular body 52. Sensor lead wires 14 extend through such lead lumen 56 and out of the proximal hub 54 such that the lead wires 14 may be connected to the computer of an image guidance system as described more fully herebelow. In some embodiments, the inner diameter D1 of the sheath lumen 216 will be large enough to allow a guidewire 10 and/or working device 30, 40, 60 to be advanced through the lumen 216 of the subselective sheath 50 and/or the outer diameter D2 of the tubular body 52 will be small enough to advance through a tubular guide 20a, 20b. The tubular body 52 of the subselective sheath 50 may be formed of a polymer such as Pebax, polyimide, high density polyethylene (HDPE), low density polyethylene (LDPE), blends of HDPE/LDPE, etc. and may have a wall thickness from approximately 0.001 inches through approximately 0.050 inches. In some embodiments, a lubricious liner or coating may be disposed within the main lumen 216 to facilitate sliding of guidewires or working devices therethrough.

[0095] Another type of sensor equipped working device of the present invention is a penetrator 60, as shown in FIG. 6. In the example shown, the penetrator 60 comprises a solid or hollow elongate body 62 (e.g., a plastic or stainless steel rod or hypotube of approximately 14 gage through approximately 27 gage having a sharp tip 64 at its distal end DE. A sensor 16, such as an electromagnetic coil, is positioned at a desired location on the penetrator, such as at or near its distal end DE. In some embodiments a sensor coil may be wrapped about the elongate body 62. A notch or depression may be formed in the

elongate body to accommodate such coil wrap and a covering, such as a plastic coating, sleeve, shrink wrap, etc. may be disposed about the coil, thereby providing a smooth outer surface and deterring direct contact of the sensor coil with body fluids or tissues. Sensor lead wires **14** extend through the elongate body **62** exiting near its proximal end PE such that they may be connected to the computer of an image guidance system as described more fully herebelow.

[0096] Any of the sensor equipped working devices (e.g., guidewires, catheters, cannula, tubes, dilators, balloons, substance injectors, needles, penetrators, cutters, debriders, microdebriders, hemostatic devices, cautery devices, cryosurgical devices, heaters, coolers, scopes, endoscopes, light guides, phototherapy devices, drills, rasps, saws, etc.) may incorporate biocompatible outer layers or coatings of lubricious material to facilitate smooth advancement of the device through the nasal anatomy, unless the inclusion of such coating would render the device unusable for its intended purpose.

[0097] Also, any of the sensor equipped working devices may incorporate a vibrator or other movement imparting apparatus to cause vibration, reciprocation, vacillation or other movement of the working device to facilitate passage of the working device through tight or tortuous anatomical passages, unless the inclusion of such vibrator or other movement imparting apparatus would render the device unusable for its intended purpose.

[0098] Also, any of the sensor equipped working devices (e.g., guidewires, catheters, cannula, tubes, dilators, balloons, substance injectors, needles, penetrators, cutters, debriders, microdebriders, hemostatic devices, cautery devices, cryosurgical devices, heaters, coolers, scopes, endoscopes, light guides, phototherapy devices, drills, rasps, saws, etc.) may incorporate internal guidewire lumens for over-the-wire use or rapid exchange type guidewire lumens (e.g., tubes, split lumens or rails on that extend along a portion of the outer wall of the catheter) to facilitate rapid device and/or guidewire exchange during the procedure, unless the inclusion of such guidewire lumen would render the working device unusable for its intended purpose. In embodiments that incorporate a rapid exchange guidewire lumen (e.g., tubes, split lumens or rails on that extend along a portion of the outer wall of the catheter) such rapid exchange guidewire lumen may have a length of from about 0.5 cm through about 10 cm. In some embodiments, the guidewire lumen may have a distal aperture at the distal end of the device and a proximal aperture located less than 10 cm proximal to the distal aperture. The sensor equipped working devices of the present invention (e.g., guidewires, catheters, cannula, tubes, dilators, balloons, substance injectors, needles, penetrators, cutters, debriders, microdebriders, hemostatic devices, cautery devices, cryosurgical devices, heaters, coolers, scopes, endoscopes, light guides, phototherapy devices, drills, rasps, saws, etc.) may be used in conjunction with an image guidance system to perform a variety of image guided procedures for the treatment of sinusitis or other disorders of the paranasal sinuses, ears, nose or throat. An example of an electromagnetic image guidance system is shown in FIGS. 7-9. This image guidance system comprises a localizer apparatus **70** and a console **76** that includes a computer workstation **78** and a video monitor **80**. As shown in FIGS. 7C and 7D, the video monitor **80** may be used in a single screen mode **80a** to single screen image or in split screen mode **80b** to simultaneously display 2 or more images.

[0099] The localizer apparatus **70**, which in this example comprises a headset, has positioning projections **71** that are configured to rest on or to insert within the ear canals and on either side of the bridge of the subject's nose such that each time the localizer apparatus **70** is worn by the subject it will remain in the same substantially fixed position relative to the subject's paranasal sinuses and intranasal anatomy, even when the subject's head is turned or moved about. Two or more radiopaque fiducial markers **72** are mounted at fixed locations on either side of the portion of the localizer apparatus **70** that resides over the subject's forehead, as shown. Also, as seen in FIGS. 7E and 9, the localizer apparatus **70** is adapted to have a transmitter assembly **75** mounted at a specific location in the center of the portion of the localizer apparatus **70** that resides over the subject's forehead. As illustrated in FIG. 8, the transmitter assembly **75** has one or more transmitter locations or sites **73** which emit electrical signals that are sensed by the sensor(s) **16** located on the working devices that will later be inserted into the subjects nose. In some cases, such as that shown in FIG. 8A, a single transmitter **75a** having single or plural (e.g., one, two, three or more) transmitter site(s) **73** may be used. If a single transmitter site **73** is used, the transmitter **71a** may emit a variable signal from the single transmitter site **73** to create a non-uniform electromagnetic field such that the position of a single sensor **16** may be determined within that electromagnetic field. If three (3) or more transmitter sites **73** are used, the transmitter **75a** may emit separate signals through each transmitter site **73** such that the location of an individual sensor **16** may be determined by a process of triangulation, similar to the manner in which GPS technology is used to determine the positions of objects on the earth's surface. In this regard, FIGS. 8B and 8C show alternative transmitters **75b**, **75c**, each of which has three (3) transmitter sites **73** at spaced apart locations which may be used for real time triangulation of the position of a single electromagnetic coil sensor **16** located on a working device **10**, **20a**, **20b**, **30**, **40**, **60**, etc. These transmitters **75a**, **75b** are constructed such that the transmission sites **73** are positioned on arm members **79a**, **79b** that emanate or extend from a central post **77**, such arm members **75a**, **75b** being configured and positioned so as to provided the needed signal transmission while not obstructing the surgeon's access to the operative field.

[0100] Referring to FIG. 7A, in one example of an image guided FTSI procedure of this invention, the subject is initially placed in a CT scanner S while wearing the localizer apparatus **70** (without the transmitter **75** mounted thereon). A pre-procedure CT scan of the head is obtained using a protocol that is compatible with the image guidance system to be used. After the pre-procedure CT scan has been completed, the CT scan data is down-loaded onto a transfer disc **82**. Also, the pre-procedure CT scan may be used for planning of the procedure. During such planning, anatomical structures of interest (e.g., ostia and sinuses) may be identified and flagged, desired instrument trajectories may be plotted (e.g., the surgeon may plan the trajectory on which a curved penetrator **60** will be advanced to create openings in or between the ethmoid air cells) and "keep out" areas may be defined (e.g., skull base, posterior/superior wall of sphenoid near pituitary, orbital floor, facial nerves, etc.)

[0101] As shown in FIG. 7B, before beginning the FTSI procedure, the CT scan data is uploaded from the transfer disc **82** into the computer **78** of the image guidance system.

[0102] With reference to FIG. 7E, the localizer apparatus 70 is again placed on the subject's head and a transmitter 75 is attached to the localizer apparatus 70. The positioning projections 71 are placed in the same locations as during the pre-procedure CT scan, thereby ensuring that the localizer apparatus 70 and its fiducial markers 72 are in the same positions relative to the subject's head as they were during the pre-procedure CT scan. The transmitter 75 is connected to the computer 78. In accordance with its programming, the computer 78 then initiates and performs a localization protocol to accomplish the "registration" process whereby the positions of the fiducial markers 72 are used to correlate the stored CT scan data with the subject's current body position. Such localization protocol may require the physician to touch the tip of a sensor equipped working device 30 or a non-sterile sensor equipped localization wand to each fiducial marker and signaling to the computer 78 when such is accomplished, thereby enabling the computer to correlate the current positions of each fiducial marker 72 within the electromagnetic field with the position of that fiducial marker 72 on the stored CT scan images.

[0103] With reference to FIG. 9, the sensor equipped tubular guide 20 may be initially inserted into the subject's nose and the sensor lead wires 14 of the tubular guide 20 connected to the console 76. The sensor equipped tubular guide 20, as well as the other sensor equipped working devices 30, may be pre-calibrated at the point of manufacture. Calibration details (e.g., length of instrument, position of sensor relative to distal tip, baseline output from additional sensors, etc.) may be stored in an electronically readable medium (e.g., a read-only tag) on or in each working device 30 such that, when each working device 30 is connected to the console 76 or a pre-calibrated handpiece, the computer 78 will read the calibration tag and will cause the image guidance system to self-calibrate accordingly. The sensor(s) 16 of the tubular guide 20 receive signals from the transmitter site(s) 76 and in turn send signals to the computer 78. The computer 78 uses such signals to determine the position of the sensor(s) 16 and/or the position of a desired portion (e.g., the distal tip) of the tubular guide 20 within the patient's body. The computer 78 also causes an indicator of the position of the sensor 16 and/or desired portion of the tubular guide 20 to appear on the video monitor 80 relative to the CT scan image displayed on the monitor 80. As the tubular guide 20 is advanced, the computer 78 will cause the displayed CT scan image to scroll from cross section to cross section, thereby providing real time monitoring of the anatomical structures in the area of the sensor 16 and/or desired portion of the tubular guide 20. While viewing the position indicator and CT scan images on the monitor 80, the physician advances the tubular guide 20 to a position where its distal tip is adjacent to (and in substantial alignment with) a sinus ostium or other structure to be treated by a working device 30.

[0104] A non-sensor equipped or sensor equipped guidewire may then be advanced through the tubular guide 20 into or through the sinus ostium or other area to be treated by the working device 30. In some cases, the guidewire may be initially inserted within the lumen of the tubular guide 20 and may be advanced along with the tubular guide 20. In other cases, the tubular guide 20 may be inserted first and the guidewire may subsequently be advanced through the lumen of the tubular guide 20. In the particular example shown in FIG. 9, a sensor equipped guidewire 10 is used. The sensor lead wires 14 of the sensor equipped guidewire 10 are

attached to the console 76 and the computer 78 performs the self-calibration in the same manner as described above. After the self-calibration for the guidewire 10 has been completed, the guidewire is advanced as the sensor(s) 16 on the guidewire 10 receive signals from the transmitter site(s) 76 and in turn the sensor(s) 16 send signals to the computer 78. The computer 78 uses such signals to determine the position of the guidewire's sensor 16 and/or a desired location on the guidewire 10 (e.g., its distal tip). The computer 78 also causes an indicator of the position of the sensor 16 and/or desired portion of the guidewire 10 to appear on the video monitor 80 relative to the CT scan image displayed on the monitor 80. In some cases, while the tubular guide 20 and guidewire 10 are both positioned within the subject's body, the monitor 80 will display indicators of the positions of both the tubular guide 20 and guidewire 10. In other cases, once the tubular guide 20 has been advanced to its intended position, the indicator of tubular guide 20 position may be deactivated so that it no longer appears on the monitor 80 and the only device position indicator appearing will then be that of the guidewire 10. In cases where position indicators for two or more working devices 30 (e.g. a tubular guide 20 and a guidewire 10) are simultaneously displayed on the monitor 80, the position indicators may be color coded or otherwise made to be distinguishable from one another. If more than one sensor-equipped device is placed in the anatomy, the surgeon (or system) must choose which device is the "master" (the device whose movement controls the position of the cross hairs and therefore which image slices are displayed) and which device is the "reference" (ie, its relative position is displayed, but movement of this device does not move the cross hairs or change which image slices are displayed). In some applications, it may be desirable to advance the guidewire 10 into a sinus or other cavity such that the guidewire 10 becomes coiled within that cavity. If the body of the guidewire is radiodense, such coiling of the guidewire within the sinus or other cavity may be used as a means to enhance visualization of the cavity by fluoroscopy or other radiographic means. In this regard, it is to be appreciated that the guidewire 10 could be equipped with a plurality of sensors 16, such that a primary sensor 16 is located at or near the distal tip and one or more secondary sensors are located along the shaft of the guidewire 10. The primary sensor 10 could remain active while the secondary sensors could be actuated and deactuated on demand. This would enable the physician to confirm that a sufficient amount of the guidewire 10 has been advanced into or past a particular anatomical location (e.g., confirm that enough of the guidewire 10 has been advanced into and coiled within a paranasal sinus).

[0105] After the guidewire 10 has been advanced to its desired position (e.g., where the distal portion of the guidewire 10 extends through the sinus ostium or other area to be treated), the sensor equipped working device 30 is inserted over the guidewire 10. In some cases, the tubular guide 20 may remain in place and the sensor equipped working device 30 will be inserted over the guidewire 10 and through the tubular guide 20, as shown in the example of FIG. 9. In other cases, the tubular guide 20 may be removed leaving the guidewire 10 in place and the working device 30 may then be inserted over the guidewire 10 alone. The sensor lead wires 14 of the sensor equipped working device 30 are attached to the console 76. The computer 78 performs a self-calibration as described above. After the self-calibration for the sensor equipped working device 30 has been completed, the sensor

equipped working device **30** is advanced over the guidewire **10**. As the working device **30** is advanced, the computer **78** receives signals from the transmitter site(s) **76** and sensor(s) **16** on the working device **30**. On the basis of such signals, the computer **78** will cause one or more indicator(s) of the position of the working device **30** to appear on the video monitor **80** relative to the CT scan image displayed on the monitor **80**. While viewing the video monitor, the physician may advance the working device **30** to a precise location within the body where its working element **36** is operatively positioned within the sinus ostium or other area to be treated. It will be appreciated that in some embodiments, a one or more sensor(s) **16** may be positioned on the working device **30** so as to delineate or mark the location of its working element **36** (e.g., sensors may be located at the proximal and distal ends of a dilation balloon or a single sensor may be positioned a known distance from the distal tip of a penetrator), thereby facilitating precise positioning of the working element **36** relative to the sinus ostium or other anatomical area to be treated by the working element **36**. In some cases where other sensor equipped devices (e.g., the tubular guide **20** and guidewire **10**) remain positioned within the subject's body along with the working device **30**, the monitor **80** may display indicators of the positions of some or all of those other devices along with the indicator of the position of the working device **30**. In other cases, the position indicator(s) of the other devices may be deactivated or caused not to be displayed on the video monitor **80** so that only the position of the working device **30** is visible. In other cases, the position indicator for the working device **30** may be displayed simultaneously with position indications of the other indwelling sensor equipped devices (e.g. tubular guide **20** and guidewire **10**) and the position indicators for each of the separate devices may be color coded or otherwise distinguishable from one another when viewed on the monitor **80**.

[0106] In some procedures, more than one working device **30** may be used. Accordingly, in such procedures, after one working device has been used to deliver a desired treatment or portion of a treatment (e.g., a balloon used to dilate the ostium of a paranasal sinus), that first working device may be removed, leaving the guidewire **30** in place. Thereafter, another working device **30** may then be advanced over the guidewire **30** and used to deliver another stage of the treatment to the same location. Or, the guidewire **10** may be moved to a different location and another working device **30** (or even the same working device **30**) may then be used to deliver a treatment to a different treatment location. This may be repeated numerous times with various different types of working devices **30**. For example, in some FTSI procedures, a first working device **30** in the form of a balloon dilation catheter **40** may be advanced over the guidewire **10**, used to dilate the ostium of a paranasal sinus and then removed, leaving the guidewire **10** in place. Thereafter, a second working device in the form of a penetrator **60** may be advanced over the guidewire **10** into the paranasal sinus and used to puncture a mucocele, mucocyst or other vesicle located on the wall of the sinus or elsewhere. The penetrator **60** may then be removed leaving the guidewire **10** in place. Thereafter, another working device **30** in the form of a tube or sheath **50** may be advanced over the guidewire **30** and used to lavage (e.g., wash out) the sinus. After the lavage is complete, the tube or sheath **50** may be removed, leaving the guidewire **10** in place, and yet another working device in the nature of a substance eluting implant delivery catheter may be advanced

over the guidewire **10** and used to place a substance eluting implant (e.g., a therapeutic implant as described in incorporated U.S. patent application Ser. Nos. 10/829,917 and 10/912,578) in or near the affected paranasal sinus. After all of the desired working devices **30** have been inserted and used, the guidewire **30** (and the tubular guide **20** if it remains at that point) may be withdrawn and removed from the subject's nasal cavity.

[0107] With reference to FIGS. **9A** and **13A-B**, the computer **78** may be programmed to display on the video monitor **80** not only an indicator **94** of the current position of a sensor equipped device **10, 20, 30, 40, 50, 60, 220** but also path indicator(s) **97** (e.g., ghosts, dotted lines, etc.) indicating the prior positions (e.g., the path of advancement) of that sensor equipped device **10, 20, 30, 40, 50, 60, 220** such that the device's path of advancement or retraction can be visualized on the monitor **80**. Optionally, some distance measurement markings **95** (e.g., hash marks) may also be displayed to allow the physician to easily determine the relative distance by which a sensor equipped device **10, 20, 30, 40, 50, 60, 220** is advanced or retracted. Alternatively or additionally, the computer **78** may optionally be programmed to display path indicator(s) **97** indicating a planned path of device advancement that is intended to be followed.

[0108] Also, optionally, the computer **78** may be programmed such that, as a sensor equipped device **30** is advanced or moved over a particular path, that path may be converted into a different type of indicia (e.g., a solid or color coded line) and displayed on the video monitor **80**. In this regard, the tip of a sensor-equipped working device **30** could be advanced, passed or swept over an anatomical surface or boundary and the computer **78** could then cause the monitor **80** to display an indication (e.g., a solid or colored line) delineating or demarcating that anatomical surface or boundary. This aspect of the invention could be used, for example, to provide on the displayed video image an outline of the inner surface of a paranasal sinus. Also, for example, this aspect of the invention could be used intraoperatively to provide a current image of the shape of an anatomical structure that is being modified in the procedure (e.g., the shape of the nasal septum during a septoplasty procedure intended to straighten the septum). Similarly, by changing a setting on the computer, the surgeon could trace with the distal tip of the sensor-equipped device the boundary of anatomical structures to be "erased" from the displayed images.

[0109] It is to be appreciated that, in some procedures of the present invention, other types of imaging such as fluoroscopy or x-ray may be used as well as the image guidance system **76**. Thus, the device so the present invention may include one or more radiopaque markers or radiographically visible region (s) to facilitate their use with fluoroscopy or x-ray.

[0110] Also, optionally, the computer **78** of the image guidance system may be programmed to accept operator input as to points or locations along a path of device advancement that should be tagged or flagged on the displayed image and/or on a recorded image maintained as a record of the procedure. These tags can then be correlated with the image guidance system so that as the physician reviews the case on the CT, the endoscopic images are linked and being "flown through" as well.

[0111] Optionally, in some procedures, it may be desirable to also insert an endoscope **84** within the subject's body to obtain an endoscopic image that may be viewed separately or concurrently with the pre-procedure scan images and indicia

of device position indicators **97, 97, 95** provided on the video monitor **80**. When so employed, the endoscope **84** may or may not be equipped with sensor(s) **16** to allow its position to be monitored by the image guidance system. Standard endoscopes used during functional endoscopic sinus surgery (FESS) may be used for this purpose, including but not limited to the Karl Storz Hopkins II rigid scope (7210AA) and the Karl Storz Flexible Rhino-Laryngoscope (11101RP) which are available commercially from Karl Storz Endoscopy—America, Culver City, Calif. In cases where the endoscope **84** is equipped with one or more sensor(s) of its own, the sensor(s) mounted on the endoscope will provide a real time indication of the position of the endoscope **84** within the subject's body. In cases where the endoscope **84** is not equipped with sensor(s) **16**, another sensor equipped guidewire **10** or device **30** may be inserted into the endoscope **84** to provide an indication of the endoscope's location within the body. For example, a non-sensor equipped endoscope **84**, such as a flexible endoscope (e.g., Karl Storz Flexible Rhino-Laryngoscope (11101RP), Karl Storz Endoscopy—America, Culver City, Calif.), may be used and a sensor equipped guidewire **10** may be inserted into (e.g., "parked" within) the working lumen of that endoscope **84**. In this manner, the sensor(s) **16** on the guidewire will provide to the computer indicia of the position of the endoscope **84** as it is navigated through the anatomy. In this manner, an indicator of the position of an endoscope **84** (or any other device into which the sensor equipped guidewire **10** may be inserted) may be displayed on the image guidance system monitor **80**, even though that endoscope **84** (or other device) is not itself equipped with a sensor **16**. A window or signal transitionable region may be formed in the endoscope to allow the sensor(s) on the guidewire **10** to receive signals from the transmitter **75**, or the portion of the guidewire **10** on which the sensor(s) is/are located may protrude out of an opening in the endoscope to allow the sensor(s) on the guidewire **10** to receive signals from the transmitter **75**. It is to be appreciated that this procedure is useable not only with endoscopes **84**, but also with any other devices into which a sensor-equipped guidewire **10** may be inserted. For example, a sensor equipped guidewire **10** may be inserted into a needle and used to guide the needle to a desired submucosal position where it is desired to deliver a substance (e.g., a drug or other therapeutic substance) or implant.

[0112] In some procedures where an endoscope **84** is employed, the visual image obtained from the endoscope **84** may be displayed on a monitor that is separate from the image guidance system monitor **80** (e.g., on a separate endoscopic tower commonly used with endoscopes during FESS). In other instances, the endoscopic image may be displayed on the image guidance system monitor **80** interchangeably with the pre-procedure scan images and indicia of device position indicators **97, 97, 95** (e.g., such that the physician may switch back and forth between a real time, line-of-sight image provided by the endoscope **84** and the pre-procedure scan images and device position indicators **97, 97, 95** provided by the image guidance system. In other instances, the image guidance system may incorporate two separate monitors **80**, one of which displays a real time, line-of-sight image provided by the endoscope **84** and the other of which displays the pre-procedure scan images and device position indicators **97, 97, 95** provided by the image guidance system. In still other instances, the image guidance system may incorporate a single monitor **80** that is operable in split screen mode such

that one portion of the monitor screen displays a real time, line-of-sight image provided by the endoscope **84** and another portion of the monitor screen displays the pre-procedure scan images and device position indicators **97, 97, 95** provided by the image guidance system. In yet other instances, the computer **78** of the image guidance system may be programmed to combine or integrate a real time, line-of-sight image that is received from the endoscope **84** with the stored pre-procedure scan images or with computer models that have been derived from the pre-procedure scan images and loaded into the image guidance system computer **78**.

[0113] FIGS. **10A** and **10B** show one example of the manner in which an endoscopic image may be used in conjunction with CT scan images to provide unique displays and images to the physician. In this example, a standard rigid endoscope is used. Typically, before the endoscope is inserted, a vasoconstricting agent e.g., cocaine, ephedrine, etc.) is sprayed into the nose. The endoscope **84** is then inserted into the nares and positioned to view the medial meatus MM, which is an open passageway adjacent to the middle turbinate MT. The uncinate process UP is a rigid structure that protrudes from the lateral wall of the nose, near the anterior end of the middle turbinate, preventing the endoscope **84** from viewing structures that lie behind the uncinate process UP. Such structures include the ethmoid bulla and an opening called the hiatus semilunaris as well as the ostium of the maxillary sinus which drains into the hiatus semilunaris. Thus, in typical FESS procedures, it is necessary for the physician to surgically incise or remove the uncinate process UP in order to view or insert rigid instruments into the ethmoid bulla, hiatus semilunaris or ostium of the maxillary sinus. However, in the example of FIG. **10A**, the computer **78** of the image guidance system has used the stored CT scan data to integrate, into the displayed endoscopic image, an anatomical structure indicator **202** (e.g., a dotted line or other demarcation) showing the position of an anatomical structure of interest that is hidden from view of the endoscope **84** by the protruding uncinate process UP and/or portions of the middle turbinate MT. In the particular example of FIG. **10A**, the anatomical structure indicator **202** is in the form of a generally circular dotted line showing the perimeter of the maxillary sinus ostium MO. A flexible sensor equipped working device **30** is being advanced through the medial meatus MM, around the intact uncinate process UP and into the maxillary ostium MO, as indicated by a device position indicator **94** and advancement path indicators **95**.

[0114] As shown in FIG. **10B**, in this example a separate video screen displays a sagittal tomographic image of the maxillary ostium MO based on the pre-procedure CT scan images that are stored in the computer **78** of the image guidance system. The computer **78** is programmed to cause an indicator **94b** of the position of the distal end of the working device **30** relative to the maxillary ostium MO. In this example the indicator **94b** is a circle, but any suitable marking or demarcation may be used. This view shown in FIG. **10B** aids the physician in advancing the distal end of the working device **30** through the maxillary ostium MO, without having to incise or remove the uncinate process UP.

[0115] Also, in some embodiments of the invention, the computer **78** may be programmed to use the distal tip of the guidewire **10** or any other location on any other working device **30** as a "virtual viewpoint" from which a virtual endoscopic view is created from the pre-procedure CT scan images and displayed on the monitor **80**.

[0116] Also included in the present invention are systems and methods for performing endoscopic medical or surgical procedures anywhere in the body of a human or animal subject. For example, an endoscope **84** having an electromagnetic sensor **16** thereon may be advanced through a portion of the subject's body while the image guidance system computer **78** receives and uses signals received from the sensor **16** on the endoscope **84** to determine the position of the endoscope within the subject's body, stores endoscopic images received from the endoscope and correlates the stored endoscopic images with locations within the subject's body. Thereafter, the operator may request an endoscopic image obtained from a specified location within the subject's body and the computer **78** may display on the video monitor **84** the stored endoscopic image obtained at the selected location. In some cases, the selected location may be the current location of a working device **30** within the subject's body. In this regard, a working device **30** that has an electromagnetic sensor **16** thereon may be positioned within the subject's body, the computer **78** may determine the position of the working device based on signals received from the sensor on the working device **30** and the computer **78** may display on the video monitor a stored endoscopic image that was previously obtained from the current location of the working device **30**. In this manner, the operator is provided with an endoscopic image of the anatomy near the working device even though the working device may not be equipped with an endoscope. In other cases, this system and method may be used to compare a real time endoscopic image to a previously stored endoscopic image. For example, an endoscope **84** having a sensor **16** thereon may be positioned within the subject's body and used to obtain a real time endoscopic image. The computer **78** may use signals received from the sensor **16** on the endoscope **84** to determine its real time position and to display a real time endoscopic image obtained from the endoscope currently positioned within the body and ii) a stored endoscopic image that was previously obtained at the same location where the endoscope **84** is currently positioned. The real time and stored endoscopic images may be displayed side by side (e.g., on separate screens or using a split screen on a single monitor **84**). This technique may be used, for example, to compare a postoperative or intra-operative endoscopic image to a previously obtained pre-operative endoscopic image for the purpose of assessing efficacy, changes, etc.

[0117] The computer **78** of the image guidance system may also be programmed to display on the image guidance system monitor **80** and/or on a separate endoscopic monitor, one or more virtual images generated from the stored CT scan data and/or the device position data received from the sensor(s) **16**. For example, virtual images of ostia, bones and portions of devices (e.g., inflated balloons) that are not visible on a displayed endoscopic image. Examples of this are shown in FIGS. 11A-11C.

[0118] FIG. 11A shows an image obtained from an endoscope **84** wherein an image guided dilation catheter **40** having a dilation balloon **46** has been advanced partially through an anatomical opening **209** and the balloon has been inflated. In this example, the computer **78** is programmed to use the information received from the sensor(s) on this balloon dilation catheter **40** to superimpose or otherwise display on the endoscopic image a virtual image (e.g., dotted line) **208** representing the portion of the inflated balloon **46** that is hidden from actual view of the endoscope.

[0119] FIG. 11B shows an image obtained from an endoscope **84** viewing an anatomical structure AS within the body. This particular anatomical structure AS is made up of bone covered with mucous membrane or other soft tissue, as is typical of structures located within the nose and paranasal sinuses. An ostium OS or opening is formed in the anatomical structure AS, as shown. In this example, the computer **78** is programmed to use information from the stored pre-procedure CT scan data to superimpose or otherwise display, on the endoscopic image, virtual images (e.g., dotted lines) **210** showing the edges of the bones that underlie the anatomical structure AS and ostium OS being viewed by the endoscope **84**.

[0120] FIG. 11C shows an image obtained from an endoscope **84** positioned within the middle meatus MM, anterior to the uncinate process UP. In this example, the computer **78** is programmed to use information from the stored pre-procedure CT scan data to superimpose or otherwise display, on the endoscopic image, virtual images (e.g., dotted lines) **214** showing the maxillary ostium MO and openings into the ethmoid air cells EO, which are hidden from the endoscope's view by the uncinate process UP. The ability to view virtual images **214** of the maxillary ostium MO and/or openings into ethmoid air cells EO may enable the physician to advance flexible or curved devices (e.g., the guidewires, catheters, penetrators and any other working devices **30**) into or through those openings MO, EO to perform treatment procedures directed at the maxillary sinuses and/or ethmoid air cells without requiring removal or surgical modification of the protruding uncinate process UP. An example of a procedure for dilation the maxillary ostium and/or delivering other treatment to the maxillary sinus is described above. Various other procedures may be performed to treat or ablate the ethmoid air cells. Some examples of the types of procedures that may be performed to treat and/or ablate the ethmoid air cells include those described in U.S. patent application Ser. No. 11/037,548 which is incorporated herein by reference.

[0121] Also, any of the working devices **10, 20, 30, 40, 50, 60** of the present invention may include, in addition to one or more of the image guidance system sensors **16**, one or more other sensors or movement indicators that may provide further information regarding the 3 dimensional position and/or orientation of the device **10, 20, 30, 40, 50, 60**. The types of other sensors or movement indication apparatus that may be used include, for example, accelerometers, strain gages (for flexible instruments), pitch/roll sensors, and capacitive sensors. FIG. 12 shows one example of a working device **220** (e.g., a guidewire, catheter, cannula, tube, dilator, balloon, substance injector, needle, penetrator, cutter, debrider, microdebrider, hemostatic device, cautery device, cryosurgical device, heater, cooler, scope, endoscope, light guide, phototherapy device, drill, rasp, saw, etc.) that comprises an elongate shaft **222**, a hub member **226** located on the proximal end PE of the shaft, an image guidance sensor **16** (e.g., an electromagnetic coil) located on the shaft **222** at a known distance from its distal end DE and a working element **36** (e.g., a dilator, balloon, injector, light delivery lens, endoscopic lens, cutter, opening, port, heater, cooler, probe, or other treatment delivering apparatus or structure). All or portion(s) of the shaft **222** may be rigid, flexible or malleable. An accelerometer **228** is mounted on one side of the hub **226**, as shown. This accelerometer **228** sends signals to the computer **78** indicating rotational movement of the device **220**. The computer **78** is programmed to process those signals and to

provide, on the basis of those signals, an indicator of the current rotational orientation of the device 220 within the subject's body. In operation, as the device may be inserted into the subject's nostril with a specific maker (not shown) or structure (e.g., one or more wings 227) of the device 220 in specific radial orientation (e.g., such that the wings 227 on the hub 226 extend vertically up and down—at the 12 o'clock and 6 o'clock positions). A foot pedal or button on the console 76 may be depressed to cause the computer 78 to identify the current position of the accelerometer 228 as the "zero" or starting position. Thereafter, any clockwise or counterclockwise rotation of the device 220 will cause signals to be sent from the accelerometer 228 to the computer 78 and the computer will cause indicia of such rotational movement of the device 220 to be shown on the monitor 80 or elsewhere.

[0122] The present invention is also useable to aid the operator in maintaining the operative instruments within pre-defined areas of the subject's body (e.g., "keep in zones") and/or to avoid advancing operative instruments into other predefined areas of the subject's body (e.g., "keep out zones"). Examples of this are shown in FIGS. 13A and 13B. As shown, the computer 78 may be programmed to display indicia (e.g., shaded and unshaded areas) demarcating keep out zones 90 and a keep in zone 92. The intended keep in zone(s) and keep out zone(s) may be electronically marked on the CT scan images during the physician's pre-procedure planning. As shown in FIG. 13A, as a sensor equipped working device 30 of the present invention is advanced or moved within the keep in zone 92, device position indicators 94 and path indicators 95 will appear only within the keep in zone 92 and no alarm (e.g., visual or audible alarm) will be provided to the operator. However, as shown in FIG. 13B, if the working device 30 is advanced or moved into either of the keep out zones 90, the device position indicator 94 will appear in the keep in zone 92 and, optionally, the computer 78 may be programmed to cause an alarm (e.g., visual or audible alarm) to be provided to the operator.

[0123] In some cases, it may be possible to maintain the subject's head in a substantially fixed position during the procedure. In those cases, the transmitter assembly 75 need not be mounted on a localizer apparatus 70 or otherwise affixed to the subject's head. Instead, in such cases, it may be possible for just the fiducial markers 72 to be affixed to the subject's body while the transmitter assembly 75 and fiducial markers 72 may be mounted on or within the operating table, on a nearby IV pole, on or in a fluoroscopic c-arm or elsewhere near the subject's body. However, in many image guided ENT procedures (including many FTSI procedures), it may be desirable to move or reposition the subject's head one or more times during the procedure. Also, in cases where the subject remains unanesthetized, it may be desirable to allow the subject to make some voluntary head movements during the procedure. Thus, it will often be desirable for the transmitter assembly 75 and fiducial markers 72 to be mounted on a localizer apparatus 70 or otherwise affixed to subject's body such that after the fiducial markers 72 have been used to perform the initial localization/registration protocol, the transmitter sites 73 will subsequently move in fixed spatial relationship to the subject's head. Certainly, a localizer apparatus 70 as shown in FIGS. 7E and 9 may be used for this purpose. However, such headset may be uncomfortable for an unanesthetized subject and/or may be an unwelcome or non-sterile obstacle located near the operative field during the procedure. Thus, the present invention provides other head

attachment devices that may be used to attach the fiducial markers 72 and transmitter(s) 75 to the subject's head during the pre-procedure CT scan and also during the procedure. In some cases these head attachment devices may comprise adhesive patches that contain the fiducial markers 72 and to which the transmitter 75 is attachable. In other cases, a mouthpiece may be used as a head affixation device. Examples of such mouthpieces 240, 240a are shown in FIGS. 14A-15C.

[0124] In the embodiment shown in FIGS. 14A and 14B, a dental mouthpiece 242 is formed of silicon or other plastic. This mouthpiece 242 may be configured based on an impression of the subject's teeth such that the positioning of the mouthpiece 242 will be reproducible from wearing to wearing. The methods for making mouthpieces 242 of this type are well known and such mouthpieces are sometimes worn by athletes who play contact sports and by some individuals who tend gnash or grind their teeth during sleep. Radiopaque fiducial markers 244, such as metal articles, are mounted at locations on the mouthpiece 242, as shown. These fiducial markers 72 may be located on the buccal sides of the mouthpiece 242 so as to be easily accessible during the localization/registration protocol where it may be necessary for a sensor equipped device 30 or a sensor equipped wand to be touched against or placed in juxtaposition to each fiducial marker 72. A transmitter assembly 75 mounting location is provided on the mouthpiece such that the transmitter 75 may be attached to the mouthpiece 242 at a predetermined, reproducible position.

[0125] The embodiment 240a shown in FIGS. 15A-15C is the same as that shown in FIGS. 14A and 14B except that it includes a transmitter mounting member 244 that is attached to the front of the mouthpiece 242. The transmitter assembly 75 may be attached to this transmitter mounting member 244. Optionally, in some embodiments, a plurality of transmitter locations or sites 73 may be at spaced apart locations along the transmitter mounting member 73 to facilitate determination (e.g., by triangulation) of the position of a single sensor 16 positioned within the subject's ears, nose, throat or paranasal sinuses.

[0126] FIGS. 16 and 17 show examples of a cable connector assembly 400 that may be used in connection with any of the sensor equipped devices of the present invention, as well as other sensor equipped devices, to facilitate transmission of signal(s) between the sensor equipped device and an image guidance system, console 76 and/or computer 78. This cable/connector assembly 400 comprises a cable 402 one end of which is connected to the sensor equipped device and the other end of which terminates in a connector 402. The sensor leads 14 extend through the cable 402 to connector 404. A corresponding connector 406 is mounted on the image guidance system console 76 or computer 78. The connectors 404, 406 may comprise multi-pin connectors as shown, or any other suitable type of connector. In some embodiments, the connectors 404, 406 may transmit either information or signals in addition to signals from the sensor(s) mounted on the device. For example, the sensor equipped device and/or connector 402 may contain a PROM, memory chip or other storage medium that holds magnetic or digitally encoded information relating to the device (e.g., calibration information, information relating the position of a sensor 16 to the distal end DE of the device, information relating the position of the sensor 16 to a working element on the device, information relating to the length, diameter or other sizing of the

device, information as to the type of device (e.g., balloon catheter, guidewire, penetrator, cutter, tubular guide, etc.) being employed or numerous other types of information). That other information may be transmitted through certain prongs, pins, channels or other contact points in the connectors **404**, **406** while the signals from the sensor(s) is/are transmitted through other prongs, pins, channels or other contact points in the connectors **404**, **406**. transmitted to the image guidance system console **76** and/or computer **78** and the connectors **404**, **406**.

[0127] With specific reference to FIG. **16**, in some cases, an optional handpiece **408** may be attached to the end of the cable **402** opposite the connector **404**. Such handpiece may perform the dual function of 1) connecting the cable **402** to the sensor equipped device and 2) providing a handpiece that the operator may use to manipulate, torque or otherwise move the device. In the particular example shown in FIG. **16**, the proximal end of a sensor equipped guidewire **10** as shown in FIGS. **1-1A** and described above, is inserted into a bore of the handpiece **408** causing the connector **21** on the proximal end of the guidewire body **12** to engage a corresponding connector (not seen in FIG. **16**) located within the handpiece **408**. In this manner, signals from the guidewire's sensor **16** will travel from the guidewire **10**, through cable **402**, to cable connector **404** and into console/computer connector **406**, thereby providing communication between the guidewire **10** and the image guidance system console **76** and/or computer **78**. When it is desired to advance another device over the guidewire **10**, the handpiece may be disengaged from the proximal end of the guidewire to permit such advancement of another device over the guidewire.

[0128] With specific reference to FIG. **17**, in cases where the handpiece **408** is not needed or desired, the cable **402** may be connected directly to the proximal portion of a sensor equipped device. In the particular example of FIG. **17**, the cable **402** is attached to the proximal hub **38** of a working device **30** that is equipped with a working element **36** and sensor **16**, as shown in FIG. **3** and described hereabove. The attachment of the cable **402** to the working device **30** may be permanent or disconnectable. In instances where the cable **402** is disconnectable from the device **30**, a plug and jack arrangement may be used to allow the cable **402** to be volitionally connected to and disconnected from the device **30**.

[0129] In some embodiments of the invention, the image guidance components (e.g., markers and/or sensors) need not be integrated into or attached to the device at the time of manufacture. Rather, in some embodiments, the image guidance components may be attachable to a working device (e.g., guidewire, guide catheter, balloon catheter, lavage catheter, needle, electrosurgical probe, stent delivery catheter, substance eluting implant delivery catheter, debrider, seeker, cannula, tube, dilator, balloon, substance injector, penetrator, cutter, debrider, microdebrider, hemostatic device, cautery device, cryosurgical device, heater, cooler, scope, endoscope, phototherapy device, drill, rasp, saw, punch, forceps and laser, etc.) at the time of the procedure. For example, FIGS. **18-19** show an example wherein an extender **500** is attached to the proximal end of a working device **502** and an optical navigation element assembly **506** is attached by way of clamp **504** to the extender **500**. In this manner, an optical IGS system **508**, such as the VectorVision® ENT image guidance system (available from BrainLAB AG, Westchester, Ill.) or LandmarX® image guidance system (available from Medtronic

Xomed Surgical Products, Inc., Jacksonville, Fla.), may be used to monitor the position of the working device within a subject's body.

[0130] More specifically, in the example shown in FIGS. **18** and **19**, the working device **502** comprises a tubular guide having a curved distal end DE, a female Luer connector **510** on its proximal end and a lumen extending therethrough. This tubular guide working device **502** is similar to the tubular guides **20a** and **20b** shown in FIGS. **2A** and **2B**, except that this tubular guide working device **502** does not incorporate any sensor **16** or wire leads **14**. Also, in this example, the extender **500** comprises a substantially cylindrical elongate body **514** having a lumen that extends longitudinally there-through, a male Luer connector **516** on its distal end and a female Luer connector **518** on its proximal end. The male Luer connector **516** on the distal end of extender **500** is connectable to the female Luer connector **510** on the proximal end of the tubular guide working device **502**. In this manner, the lumen of the extender **500** is substantially continuous with the lumen of the tubular guide working device **502** such that other working devices (e.g., guidewires, balloon catheters, lavage catheters, needles, electrosurgical probes, stent delivery catheters and substance eluting implant delivery catheters, debriders, seekers, cannulae, tubes, dilators, balloons, substance injectors, penetrators, cutters, debriders, microdebriders, hemostatic devices, cautery devices, cryosurgical devices, heaters, coolers, scopes, endoscopes, phototherapy devices, drills, rasps, saws, punches, forceps and lasers, etc.) may be inserted into the proximal end PE of the extender **500** and advanced through the extender **500**, through the tubular guide working device **502** and out of its distal end DE. Although the embodiment of the invention shown in FIGS. **18** and **19** is a tubular device with a cylindrical wall, the extender can also be a partially cylindrical wall or non-tubular extender. Also, the extender **500** may perform other optional functions. For example, prior to or after the clamp **530** has been attached to the extender **500**, the extender **500** may be used as a handle to facilitate grasping and control of the tubular guide working device **502**.

[0131] In the example shown, the tubular guide working device **502** has a curve **520** formed near its distal end. The angle A of such curve may range from 0 to about 110 degrees. Alternatively, all or part of this tubular guide working device **502** may be made of plastically deformable or malleable material such that the operator may customize the shape of this device **502** before or during the procedure.

[0132] Also in the example of FIGS. **18-19**, the navigation element assembly **506** comprises a hub member **522**, a plurality of radiating arms **524** that extend radially from the hub member **522** and a plurality of active or passive navigation elements **526** attached to the radiating arms **524**. Examples of active optical navigation elements include light emitters, such as light emitting diodes (LEDs). Examples of passive optical navigation elements include reflective members (e.g., spheres) that reflect light, such as infrared light emitted from one or more infrared light sources located in proximity to the device. The bottom end of the hub member **522** is configured to be received by or otherwise attached to the clamp **504**. In the depicted example, the bottom end of the hub member **522** is received within an upstanding sleeve portion **528** of clamp **504** and a locking pin **530** is used to hold the navigation element assembly **506** in substantially fixed rotational position relative to the clamp **504**. The body portion **532** of clamp **504** is designed to fit upon and frictionally engage the cylin-

drical body **514** of the extender **500** such that the clamp **504** and navigation element assembly **506** will be firmly attached to the extender and, thus, will be held in substantially fixed position relative to the extender **500** and the tubular guide working device **502** to which the extender **500** has been attached. The extender **500** in some embodiments can have features to enhance the attachment of the navigation element assembly to the extender in substantially fixed rotational position such as knurling, indentations, etc. One commercially available example of a navigation element assembly **506** and clamp **504** having the general configuration shown in FIGS. **18** and **19** is the STARLINK™ Universal Instrument Adapter manufactured by BrainLAB, Inc., Westchester, Ill.

[0133] Although FIGS. **18** and **19** show an embodiment where the navigation element assembly **506** is attachable to and detachable from the extender **500**, it is to be appreciated that, in some other embodiments of this invention, the clamp **504** and/or navigation element assembly **506** may be integrated into or pre-attached to the extender **500**. For example, a clamp or other fitting designed to receive and attach the navigation element assembly **506** may be molded into or pre-attached to the extender **500**. Or, all or part of the navigation element assembly **506** (e.g., with or without inclusion of the active or passive navigation elements **526**) may be molded into or pre-attached to the extender **500**.

[0134] The IGS system **508** generally comprises a monitor **534** and one or more camera(s) **538**. Additionally, when the navigation elements **525** are passive (e.g., reflective) rather than active (e.g., light emitting), the IGS system **508** may further comprise one or more light emitter(s) **536** (e.g., infrared lamps) which emit light that is reflected by the passive markers **526**. Additionally, the IGS system incorporates a computing device (e.g., a computer or microprocessor) that is loaded with software for calibration and tracking of the distal end DE of tubular guide working device **502** and/or other working devices within the subject's body. A user interface (e.g., a keypad, keyboard, touch screen, other data entry apparatus, etc.) may also be provided to enable the user to enter parameters or information into the system **508**. In some embodiments, the computing device **540** may be programmed with software that includes a database containing design parameters (e.g., length, curvature/shape, etc.) for a number of tubular guides and/or other working devices to which the extender **500** may be attached. In such embodiments, the user interface device is used to enter or detect the particular type of working device. Typically, the user enters the type of guide device **100** (e.g. a maxillary sinus ostium access guide device) in the surgical navigation system. The software in the surgical navigation system then calibrates the position and/or orientation of the distal tip of guide device **100** to navigational unit **118**, and hence to the surgical navigation system.

[0135] In typical operation, the male Luer connector on the distal end of the extender **500** is firmly attached to the female Luer connector **510** on the proximal end of the tubular guide working device **502**. The navigation element assembly **506** is attached to the clamp **504** and the clamp **504** is firmly mounted on the extender **500**, as described above. Stored anatomical images, such as CT scan images are displayed on the monitor **534** of the IGS system **508**. In some cases, a facemask or other headgear containing fiducial markers may have been worn by the subject as the CT scan images (or other anatomical images) are obtained and the locations of the fiducial markers on the scanned images may then be used for

purposes of registration in accordance with the instructions provided by the manufacturer of the IGS system. Examples of headgear containing fiducial markers that may be used for this purpose include those devices shown in FIGS. **7E**, **9** and **14A-15C** of this application as well as those devices commercially available as the Reference Headband/Reference Star (BrainLAB, Inc., Westchester, Ill.) and the Framelock™ kit (Medtronic Xomed Surgical Products, Inc., Jacksonville, Fla.) In other cases, the subject may not have worn fiducial markers during the prior CT scan (or other anatomical imaging procedure) and, instead, an alternative calibration technique may be used. For example, the position and/or the trajectory of the distal end DE of the tubular guide working device **502** may be calibrated to the surgical navigation system using an anatomical landmark of the patient's body. To facilitate this, a device such as the Z-Touch® Registration System (BrainLAB, Inc., Westchester, Ill.) may be used. Such Z-Touch® Registration System is a special laser pointer that allows the VectorVision® IGS system to utilize the surface anatomy of the subject's face and head to calculate an advanced surface-matching algorithm and calibrate the system to the patient's scan. Or, in another alternate method embodiment, the position of the distal tip of guide device **100** may be calibrated to the surgical navigation system using a calibration device such as VectorVision® ENT ICM4 Instrument Calibration Tool (Brainlab, Inc., Westchester, Ill.) that comprises one or more fiducial markers used for calibration purposes.

[0136] After any required calibration has been performed, the distal end DE of the tubular guide working device **502** may be inserted trans-nasally and advanced to a position where the distal end DE is in alignment with or adjacent to a desired treatment sight, such as the ostium of a paranasal sinus. Thereafter, a second working device (e.g., guidewire, guide catheter, balloon catheter, lavage catheter, needle, electrosurgical probe, stent delivery catheter, substance eluting implant delivery catheter, debrider, seeker, cannula, tube, dilator, balloon, substance injector, penetrator, cutter, debrider, microdebrider, hemostatic device, cautery device, cryosurgical device, heater, cooler, scope, endoscope, phototherapy device, drill, rasp, saw, punch, forceps and laser, etc.) may be inserted into the proximal end PE of the extender **500**, advanced through the lumen of the extender **500**, through the lumen of the tubular guide working device **502** and out of its distal end DE to the desired treatment location where such second working device may be used to perform a desired therapeutic or diagnostic function. One such therapeutic function would be to dilate an opening of a paranasal sinus by a) using the IGS system to position the distal end DE of the tubular guide working device **502** adjacent to or in alignment with the opening of the paranasal sinus, b) advancing a dilation catheter through the extender **500** and through the tubular guide working device **500** and into the opening of the paranasal sinus and c) using the dilation catheter to dilate the opening of the paranasal sinus. Additionally or alternatively, fluids or substances may be infused through the extender **500** and through the tubular guide working device **502** for purposes of lavage, imaging or treatment delivery.

[0137] FluoroCT is a relatively new technology in which a C-arm type three-dimensional (3D) imaging device (e.g., the ISO-C3D available from Siemens Medical Systems) is used to obtain a fluoroscopic computed tomogram. Because these C-arm devices may be mobile, Fluoro CT scans may be obtained intraoperatively and immediately postoperatively,

as well as preoperatively. In some cases, FluoroCT may be used to obtain the pre-procedure imaging data stored in the image guidance system computer 78. Additionally, in some cases, one or more FluoroCT scans may be obtained during or after the procedure and data sets from such intraoperative or postoperative FluoroCT scans may be loaded into the computer 78. The computer 78 may be programmed to use such FluoroCT scan data to update the previously stored imaging data that has been obtained by traditional CT, MRI, FluoroCT or other means, thereby adjusting the stored anatomical image data to show changes to the anatomy that have occurred subsequent to the pre-operative scan. Additionally or alternatively, the computer may be programmed 78 to display the newly added FluoroCT data in addition to or in comparison with other images based on the preoperative scan, thereby allowing the surgeon to compare the current (e.g., intraoperative or postoperative) anatomy to the preoperative anatomy.

[0138] It is to be appreciated that the computer 78 of the image guidance system may be programmed with a number of optional programs (e.g., software bundles) to provide additional or different features. The following are non-limiting examples of some of the optional capabilities that may be programmed into the computer 78:

[0139] Device Path Suggestion Feature:

[0140] The computer 78 may, in some embodiments, be programmed to automatically suggest path(s) of advancement or vector(s) along which a desired device (e.g., a sensor equipped working device 30) may be advanced to reach a desired location (e.g., the ostium of a particular paranasal sinus, the ethmoid air cells, a site of infection, a bulla, a mucocele, a mucocyst, etc.) The suggested path(s) of advancement or vector(s) may be selected based on operator-input criteria (e.g., least complex path, least tortuous path, least traumatic path, safest path, etc.) After it has determined the desired path(s) or vector(s) the computer 78 may cause indicia of such desired path(s) or vector(s) (e.g., dotted lines) to appear on the video monitor 80 in relation to the displayed anatomical CT and/or endoscopic images.

[0141] Path Ahead Mode:

[0142] The computer 78 may, in some embodiments, be programmed to display not only the anatomical structures that are adjacent to or near the current position of a sensor equipped working device 30, but also anatomical structures that are located ahead on one or more path(s) on which the device 30 may be advanced from its current position to reach its target position. In this regard, the computer 78 may cause the monitor 80 to display 1) a tomographic section or other anatomical image of the area in which the working device 30 is currently located (the “current location image”) and 2) one or more other tomographic sections or other images showing anatomical structures that lie ahead on one or more intended path(s) of advancement (the “path ahead image(s)). The current location image and the path ahead image(s) may be displayed simultaneously (e.g., on separate monitors, on a split screen monitor or on a single screen where with one image is inset within a larger image). Alternatively, current location image and the path ahead image(s) may be displayed one at a time such that the operator may switch back and forth between the current location image and the path ahead image (s).

[0143] Pre-Post Comparison Mode:

[0144] The computer 78 may, in some embodiments, be programmed to take the stored pre-procedure imaging scan data and compare it to subsequently input a post-procedural

or intra-operative imaging scan data such that the effects or anatomical changes caused by the procedure may be assessed.

[0145] Turn Cueing Mode:

[0146] The computer 78 may, in some embodiments, be programmed to provide a turn indicator (e.g., an audible signal or visual indicator shown on the monitor screen) to indicate the direction that a guidewire 10 or other sensor equipped working device 30 should be turned to navigate toward a desired target location.

[0147] Treatment Forecasting

[0148] The computer 78 may, in some embodiments, be programmed to utilize the stored anatomical image data (e.g., CT scan data) to provides prompts or suggestions of 1) anatomical structures or pathological lesions that may be amenable to a particular treatment and/or 2) optimal or suggested locations and/or rotational orientations in which working device(s) 30 may be placed in order to effect a particular treatment and/or 3) the optimal or suggested size or dimensions of the working device(s) 30 to be used (e.g., for regions marked in red a 6 mm balloon diameter is suggested and for regions marked in blue a 7 mm balloon is suggested).

[0149] Simulation of Result

[0150] The computer 78 may, in some embodiments, be programmed to provide a simulated result of a particular procedure before the procedure is actually performed. The ability to generate a simulated result may be particularly advantageous in cases where it is not feasible for the physician to actually view the area being treated and, thus, is unable to make a visual assessment of such area as may be needed to arrive at an accurate prediction of the likely therapeutic and/or untoward results of a proposed treatment or maneuver. For example, the console 76 and computer 78 may be adapted to receive operator input of the particular diameter (or other dimensions/characteristics) of a dilator balloon that the physician proposes to use for dilation of a particular passageway. The computer 78 will be programmed with software that it will use to provide a simulated view of what that passageway would look like after it has been dilated by that proposed balloon and what submucosal, adjacent or hidden anatomical structures would likely be compressed or otherwise affected by such dilation procedure, if the procedure were actually performed using a balloon having the proposed diameter, dimensions and/or characteristics.

[0151] Simulation of Device

[0152] The computer 78 may, in some embodiments, be programmed to provide a simulated view of a particular device that is positioned within the subject’s body. For example, the computer 78 may be programmed with device information (e.g., the dimensions, shape and appearance of the device) and, after tracking the trajectory of a the sensor 16 mounted on that device through the anatomy, the computer 78 may generate and display on the monitor 80, a “virtual” image of the device as it is positioned relative to the adjacent anatomy. This aspect of the invention may provide to the operator some “feel” for the relative 3 dimensional size and position of the device within the body.

[0153] Look Ahead Mode

[0154] The computer 78 may, in some embodiments, be programmed to provide a simulated view from a vantage point on a device that has been inserted into the subject’s body. For example, the computer 78 may cause the monitor to display a forward looking view from the distal tip of an

advancing guidewire as if the operator were sitting on the distal tip of the guidewire and looking forward at the anatomy as the guidewire is advanced.

[0155] Also, it is to be appreciated that any working device 30 may incorporate endoscopic components (e.g., fiber optic light guide, fiber optic image transmission bundle, lenses, etc.) as well as other working elements 36. In this regard, the working device 30 may comprise an on board endoscope that is useable to view some or all of the procedure wherein that working device 30 is employed. Alternatively, it is to be appreciated that any working device 30 may be inserted or incorporated into an endoscope such that the endoscope may be used to view some or all of the procedure wherein that working device 30 is employed.

[0156] Also, in any device or system described herein, the locations of the sensor(s) 16 and transmitter(s) 75 or transmitter sites 73 may be switched. For example, one or more transmitter sites 73 may be located on a transmitter equipped device (e.g., a guidewire, tubular guide, sheath, dilation catheter or other device having a working element as described herein) and one or more sensors 16 may be located on a localizer apparatus 70 such as a localizer frame or headset.

[0157] The use of the sensor equipped working devices 30 and methods of the present invention may serve a number of purposes and may provide a number of advantages over the prior art. For example, the use of such image guided devices and methods may permit very precise positioning and movement of devices within the subject's body, thereby improving the safety of the procedure, causing less trauma or unnecessary iatrogenic tissue modification, requiring less use of fluoroscopy or x-ray and hence less radiation exposure to the subject or the operator(s), etc.

[0158] It is to be further appreciated that the invention has been described hereabove with reference to certain examples or embodiments of the invention but that various additions, deletions, alterations and modifications may be made to those examples and embodiments without departing from the intended spirit and scope of the invention. For example, any element or attribute of one embodiment or example may be incorporated into or used with another embodiment or example, unless to do so would render the embodiment or example unsuitable for its intended use. All reasonable additions, deletions, modifications and alterations are to be considered equivalents of the described examples and embodiments and are to be included within the scope of the following claims.

1.-23. (canceled)

24. A method for image guided performance of a treatment procedure to treat a paranasal sinus in a human or animal subject, said method comprising the steps of:

- (a) providing a working device, wherein at least a portion of said working device is insertable into a paranasal sinus of the subject and is useable to carry out or facilitate at least a portion of said treatment procedure, wherein the working device has a proximal end and a distal end, wherein the working device further includes a sensor;
- (b) providing an image guidance system that is useable to determine the location of the working device within the paranasal sinus of the subject on the basis of signals received from the sensor;
- (c) inserting the working device such that the distal end of the working device is within an ear, nose, throat, or paranasal sinus of the subject; and

- (d) using the image guidance system to detect the position of the distal end of the working device within the paranasal sinus of the subject;

- wherein the working device comprises an elongate member having an expandable dilator thereon;

- wherein the expandable dilator is sized and constructed to be positioned within the ostium of a paranasal sinus while in a non-expanded state and the thereafter be expanded to an expanded state, thereby enlarging the ostium;

- wherein the ostium in which the expandable dilator is to be positioned comprises a bone that underlies mucous membrane and wherein the expandable dilator is further constructed to exert sufficient force against the ostium to break bone that underlies the mucous membrane;

- wherein the location at which the sensor is positioned is in known relationship to the distal end of the working device such that the location of the sensor detected by the image guidance system will enable the operator to determine the position of the distal end of the working device within an ear, nose, throat, or paranasal sinus of the subject.

25. A method according to claim 24, wherein the sensor is located near the proximal end of the working device.

26. A method according to claim 24, wherein the sensor comprises an electromagnetic coil.

27. A method according to claim 24, wherein the location at which the sensor is positioned is in known relationship to the position of the expandable dilator such that the location of the sensor detected by the image guidance system will enable the operator to determine the position of the dilator within an ear, nose, throat or paranasal sinus of the subject.

28. A method according to claim 24, wherein the expandable dilator comprises a balloon.

29. A method according to claim 24, wherein the image guidance system comprises:

- (i) a computer,
- (ii) a video monitor,
- (iii) a localizer, and
- (iv) a sensor tracking system.

30. A method according to claim 29, wherein anatomical image data has been obtained from the subject prior to performance of inserting the working device and using the image guidance system to detect the position of the distal end of the working device within a paranasal sinus of the subject, wherein prior to or during performance of using the image guidance system to detect the position of the sensor within a paranasal sinus of the subject, the localizer is used to register the anatomical image data with the physical positioning of the subject's body.

31. A method according to claim 30, wherein using the image guidance system to detect the position of the sensor within a paranasal sinus of the subject comprises causing the anatomical image data to be received by the computer, wherein the computer causes the video monitor to display an anatomical image from the anatomical data along with an indicator indicating the location of the working device in relation to the anatomical image.

32. A method according to claim 30, wherein the computer i) receives working device location data from the sensor tracking system, ii) integrates the working device location data with the anatomical image data, and iii) causes the video monitor to display an anatomical image along with an indi-

cator indicating the position of the working device relative to the displayed anatomical image.

33. A method according to claim 30, wherein the anatomical image data comprises one or more of the following: tomographic image data, data obtained by CT or fluoroscopic CT scan, or data obtained by PET scan.

34. A method according to claim 30, wherein the anatomical image data includes data providing a plurality of orthogonal views of the subject's anatomy.

35. A method according to claim 24, wherein the image guidance system comprises a transmitter that transmits a signal that is sensed by the sensor on the working device.

36. A method according to claim 24, wherein the image guidance system comprises an electromagnetic tracking system, wherein the sensor on the working device comprises an electromagnetic sensor.

37. A method according to claim 24, wherein the image guidance system receives a video image from an endoscope or endonasal camera positioned within an ear, nose, throat, or paranasal sinus of the subject and displays that video image on a video monitor along with an indication of the location of the working device.

38. A method according to claim 24, wherein the treatment procedure includes the transnasal insertion and advancement of the distal end of the working device into or through the ostium of a maxillary sinus without removing or causing substantial trauma to the uncinate process.

39. A method according to claim 24, wherein the treatment procedure includes the transnasal insertion and advancement of the distal end of the working device into or through the ostium of a sphenoid sinus without removing, altering or causing substantial trauma to the ethmoid air cells, middle turbinate, superior turbinate, or supreme turbinate.

40. A method according to claim 24, wherein the treatment procedure includes the transnasal insertion and advancement of the distal end of the working device into or through the ostium of a frontal sinus without removing or causing substantial trauma to the process, ethmoid bulla, or middle turbinate.

41. A method according to claim 24, wherein the treatment procedure includes the transnasal insertion and advancement of the distal end of the working device into or through an ethmoid bulla without removing or causing substantial trauma to the uncinate process.

42. A method for image guided performance of a treatment procedure to treat a human or animal subject, said method comprising the steps of:

- (a) providing a working device, wherein the working device comprises:
 - (i) an elongate member having a proximal end and a distal end, wherein the distal end includes a rigid curved section,

- (ii) an expandable dilator positioned on the elongate member, wherein the expandable dilator is sized and constructed to be positioned within a drainage passageway of a paranasal sinus while in a non-expanded state and the thereafter be expanded to an expanded state, thereby enlarging the drainage passageway, and
- (iii) a sensor;

(b) providing an image guidance system that is useable to determine the location of the working device in relation to the paranasal sinus of the subject on the basis of signals associated with the sensor;

(c) inserting the working device such that the distal end of the working device is within a nose or paranasal sinus of the subject; and

(d) using the image guidance system to detect the position of the distal end of the working device in the subject;

wherein the location at which the sensor is positioned is in known relationship to the distal end of the working device such that the location of the sensor detected by the image guidance system will enable the operator to determine the position of the distal end of the working device within a nose or paranasal sinus of the subject.

43. A method for image guided performance of a treatment procedure to treat a human or animal subject, said method comprising the steps of:

(a) providing a working device, wherein the working device comprises:

- (i) an elongate member having a proximal end and a distal end,
- (ii) an expandable dilator positioned on the elongate member, wherein the expandable dilator is sized and constructed to be positioned within a drainage passageway of a paranasal sinus while in a non-expanded state and the thereafter be expanded to an expanded state, thereby enlarging the drainage passageway, and
- (iii) a sensor positioned near the proximal end of the elongate member;

(b) providing an image guidance system that is useable to determine the location of the working device in relation to the paranasal sinus of the subject on the basis of signals associated with the sensor;

(c) inserting the working device such that the distal end of the working device is within a nose or paranasal sinus of the subject; and

(d) using the image guidance system to detect the position of the distal end of the working device in the subject;

wherein the location at which the sensor is positioned is in known relationship to the distal end of the working device such that the location of the sensor detected by the image guidance system will enable the operator to determine the position of the distal end of the working device within a nose or paranasal sinus of the subject.

* * * * *