

(19) World Intellectual Property Organization  
International Bureau



(43) International Publication Date  
9 November 2006 (09.11.2006)

PCT

(10) International Publication Number  
WO 2006/119004 A2

(51) International Patent Classification: Not classified

(21) International Application Number:  
PCT/US2006/016198

(22) International Filing Date: 27 April 2006 (27.04.2006)

(25) Filing Language: English

(26) Publication Language: English

(30) Priority Data:  
11/119,877 2 May 2005 (02.05.2005) US

(71) Applicant: 3M INNOVATIVE PROPERTIES COMPANY [US/US]; 3M Center, Post Office Box 33427, Saint Paul, MN 55133-3427 (US).

(72) Inventors: SPARTZ, Gerald, R.; 3M Center, Post Office Box 33427, Saint Paul, MN 55133-3427 (US). KIRK, Seth, M.; 3M Center, Post Office Box 33427, Saint Paul, MN 55133-3427 (US). JONES, Marvin, E.; 3M Center, Post Office Box 33427, Saint Paul, MN 55133-3427 (US). CABIBIL, Hyacinth, L.; 3M Center, Post Office Box 33427, Saint Paul, MN 55133-3427 (US). ROUSSEAU, Alan, D.; 3M Center, Post Office Box 33427, Saint Paul, MN 55133-3427 (US). PACHUTA, Steven, J.; 3M Center, Post Office Box 33427, Saint Paul, MN 55133-3427 (US).

(74) Agents: HANSON, Karl, G. et al.; 3M Center, Office of Intellectual Property Counsel, Post Office Box 33427, Saint Paul, MN 55133-3427 (US).

(81) Designated States (unless otherwise indicated, for every kind of national protection available): AE, AG, AL, AM, AT, AU, AZ, BA, BB, BG, BR, BW, BY, BZ, CA, CH, CN, CO, CR, CU, CZ, DE, DK, DM, DZ, EC, EE, EG, ES, FI, GB, GD, GE, GH, GM, HR, HU, ID, IL, IN, IS, JP, KE, KG, KM, KN, KP, KR, KZ, LC, LK, LR, LS, LT, LU, LV, LY, MA, MD, MG, MK, MN, MW, MX, MZ, NA, NG, NI, NO, NZ, OM, PG, PH, PL, PT, RO, RU, SC, SD, SE, SG, SK, SL, SM, SY, TJ, TM, TN, TR, TT, TZ, UA, UG, US, UZ, VC, VN, YU, ZA, ZM, ZW.

(84) Designated States (unless otherwise indicated, for every kind of regional protection available): ARIPO (BW, GH, GM, KE, LS, MW, MZ, NA, SD, SL, SZ, TZ, UG, ZM, ZW), Eurasian (AM, AZ, BY, KG, KZ, MD, RU, TJ, TM), European (AT, BE, BG, CH, CY, CZ, DE, DK, EE, ES, FI, FR, GB, GR, HU, IE, IS, IT, LT, LU, LV, MC, NL, PL, PT, RO, SE, SI, SK, TR), OAPI (BF, BJ, CF, CG, CI, CM, GA, GN, GQ, GW, ML, MR, NE, SN, TD, TG).

**Declarations under Rule 4.17:**

- as to applicant's entitlement to apply for and be granted a patent (Rule 4.17(ii))
- as to the applicant's entitlement to claim the priority of the earlier application (Rule 4.17(iii))

**Published:**

- without international search report and to be republished upon receipt of that report

For two-letter codes and other abbreviations, refer to the "Guidance Notes on Codes and Abbreviations" appearing at the beginning of each regular issue of the PCT Gazette.

(54) Title: ELECTRET ARTICLE HAVING HIGH FLUOROSATURATION RATIO

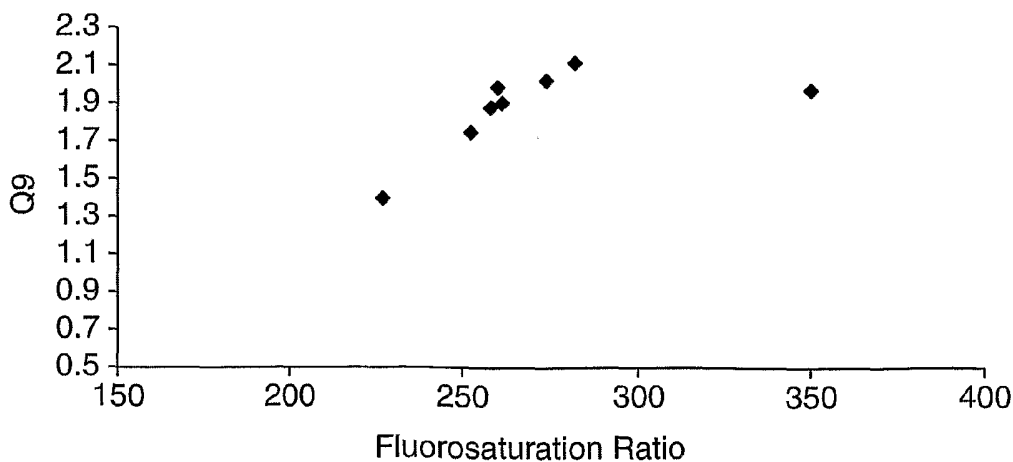

(57) Abstract: An electret article that includes a polymeric material that has electric charge imparted thereto, that has a CF?3#191:CF?2#191 ratio of at least 0.15 and that has a fluorosaturation ratio greater than about 200. The electret article may be in the form of a porous web of polymeric fibers suitable for use as a filter. The inventive electret article is resistant to charge degradation upon exposure to high temperatures for prolonged time periods.

WO 2006/119004 A2

## ELECTRET ARTICLE HAVING HIGH FLUOROSATURATION RATIO

[0001] The present invention pertains to a polymeric electret article that has a  $\text{CF}_3:\text{CF}_2$  ratio of at least 0.15 and that has a fluorosaturation ratio greater than about 200. The inventive electret article is resistant to charge degradation upon exposure to high temperatures for prolonged time periods.

### BACKGROUND

[0002] Electret articles — that is, dielectric articles that exhibit at least quasi-permanent electric charge — are known to exhibit good filtration properties. The articles have been fashioned in a variety of constructions, but for air filtration purposes, the articles commonly take the form of a nonwoven polymeric fibrous web. An example of such a product is the Filtrete™ brand furnace filter sold by the 3M Company. Nonwoven polymeric electret filters are also used in personal respiratory protection devices — see, for example, U.S. Patent 5,307,796 to Kronzer et al., U.S. Patent 5,804,295 to Braun et al., and U.S. Patent 6,216,693 to Rekow et al.

[0003] A variety of methods have been used to make electrets, including fiber/electric particle bombardment (U.S. Patent 4,215,682 to Kubik et al.), direct current "DC" corona charging (see, U.S. Patents Re. 30,782 and 32,171 to van Turnhout and U.S. Patent 4,592,815 to Nakao), hydrocharging (see, U.S. Patents 5,496,507, 6,119,691, 6,375,886, and 6,783,574 to Angadjivand et al., U.S. Patent 6,406,657 to Eitzman et al., and U.S. Patent 6,743,464 to Insley et al.), and from exposure to polar liquids (U.S. Patent 6,454,986 to Eitzman et al.). The electric charge that is imparted to the dielectric article is effective in enhancing particle capture.

[0004] In addition to fibrous structures, microstructured or microchanneled filter media have been electrically charged to improve the filtration performance (see, for example, U.S. Patent 6,524,488 to Insley et al.).

[0005] During use, electret filters frequently become loaded with particles and contaminants that interfere with the filtering capabilities of the electret filter. Liquid aerosols, for example, particularly oily aerosols, may cause electret filters to lose their electret-enhanced filtering efficiency (see, U.S. Patent 6,627,563 to Huberty).

[0006] Numerous methods have been developed to counter this filtering efficiency loss. One method includes adding additional layers of nonwoven polymeric web to the filter. This approach, however, can increase the pressure drop across the electret filter and can add to its weight and bulk. When the electret filter is used in a personal respiratory protection device, these drawbacks can be particularly troublesome. Increased pressure drop, for example, results in increased breathing resistance, making the respirator more uncomfortable to wear. Another method for improving resistance to oily-mist aerosols, includes adding a melt processable fluorochemical additive such as a fluorochemical oxazolidinone, a fluorochemical piperazine, or a perfluorinated alkane to the polymer during the creation of the polymeric fibrous article — see, for example, U.S. Patents 5,025,052 and 5,099,026 to Crater et al. and U.S. Patents 5,411,576 and 5,472,481 to Jones et al. The fluorochemicals are melt processable, that is they suffer substantially no degradation under the melt processing conditions that are used to form the fibers in the electret web — see also U.S. Patent 5,908,598 to Rousseau et al. In addition to a melt-processing method, fluorinated electrets also have been made by placing a polymeric article in an atmosphere that contains a fluorine-containing species and an inert gas and then applying an electrical discharge to modify the surface chemistry of the polymeric article. The electrical discharge may be in the form of a plasma such as an AC corona discharge. The plasma fluorination process causes fluorine atoms to become present on the surface of the polymeric article. The fluorinated polymeric article may be electrically charged using, for example, the hydrocharging techniques mentioned above. The plasma fluorination process is described in a number of U.S. Patents to Jones/Lyons et al.: 6,397,458, 6,398,847, 6,409,806, 6,432,175, 6,562,112, 6,660,210, and 6,808,551. Other publications that disclose fluorination techniques include: U.S. Patents 6,419,871, 6,238,466, 6,214,094, 6,213,122, 5,908,598, 4,557,945, 4,508,781, and 4,264,750; U.S. Publications US 2003/0134515 A1 and US 2002/0174869 A1; and International Publication WO 01/07144.

[0007] Although fluorinated electrets are suitable for many filtration applications, some filters require enhanced thermal stability to meet product specifications, for example, military specifications and NIOSH requirements — see NIOSH, Statement of Standard for Chemical, Biological, Radiological, and Nuclear (CBRN) Air-Purifying Escape

Respirator, Attachment A, September 30, 2003 and NIOSH, Statement of Standard for Chemical, Biological, Radiological, and Nuclear (CBRN) Full Facepiece Air Purifying Respirator (APR), Appendix A, April 4, 2003. Applications exist where the electret filter media should be resistant to charge degradations at high temperatures for prolonged periods. The present invention described below addresses this need and accordingly provides an electret article that has good oily mist filtration properties despite being exposed to high temperatures for extended time periods.

SUMMARY OF THE INVENTION

[0008] The present invention provides a new fluorinated polymeric article, which article comprises a polymeric material that has an electret charge imparted thereto, that has a  $CF_3$  to  $CF_2$  ratio of at least about 0.15, and that has a fluorosaturation ratio greater than about 200. The present invention differs from known fluorinated electret articles in that it has a combination of  $CF_3$  to  $CF_2$  and fluorosaturation ratios not heretofore described or recognized in the polymeric electret article art. The inventors discovered that a polymeric electret article that has such ratios can exhibit improved filtration performance under stressed thermal conditions. In the electret articles described in the Jones/Lyons et al. patents mentioned above, the  $CF_3:CF_2$  ratio is described as being at least about 0.25, preferably at least about 0.45, and more preferably greater than 0.9. The Jones/Lyons et al. patents, however, are silent in regard to a fluorosaturation ratio and any benefits that such a ratio may have with respect to charge stability.

Tetrafluoroethylene/hexafluoropropylene copolymer (also known as fluorinated ethylene propylene or "FEP") and polytetrafluoroethylene ("PTFE") have been used as electret articles in, for example, transducers. See G.M. Sessler, *Electrets*, v. 1, pp. 374-381 (1998). Although FEP has some  $CF_3$  component — measured to be approximately 0.11 to the amount of  $CF_2$  — PTFE has a negligible amount of  $CF_3$ . Thus, no product heretofore produced is known to have the  $CF_3:CF_2$  ratio and fluorosaturation ratios of this invention; nor is there any known electret product that has such ratios and exhibits the thermal stability of the present invention.

[0009] The filtering performance of an electret article is commonly characterized using a parameter that is referred to in the art as "quality factor" or "Q value". The Q value characterizes filtration performance as a blend of the particle penetration and pressure drop

parameters. As indicated above, some filters require enhanced thermal stability to meet filtration product specifications. Applications exist where the electret filter media should be resistant to charge degradation at high temperatures. Applicants demonstrate that extraordinary quality factor data can be maintained when testing the inventive electret articles after an accelerated high-temperature aging exposure. Specifically, applicants have shown that extraordinary quality factor data can be achieved after 9 hours of aging at 100 °C. The Q value that results from this test is referred to as "Q9". The inventors discovered that by providing an electret article that has a CF<sub>3</sub> to CF<sub>2</sub> ratio of at least 0.15 with a fluorosaturation ratio greater than about 200, increased thermal stability — as measured by the Q9 value — can be achieved. The inventive electret articles thus can maintain good filtration efficiency despite being "aged" at high temperatures for an extended time period.

[0010] These and other features or advantages of the invention are more fully shown and described in the drawings and detailed description of this invention, where like reference numerals are used to represent similar parts. It is to be understood, however, that the drawings and description are for the purposes of illustration only and should not be read in a manner that would unduly limit the scope of this invention.

#### GLOSSARY

[0011] The terms set forth below will have the meanings as defined:

[0012] "aerosol" means a gas that contains suspended particles in solid or liquid form;

[0013] "atomic percent fluorine" means the amount of fluorine determined according to the Method for Determining Surface Concentration of Fluorine Using X-Ray Photoelectron Spectroscopy (XPS);

[0014] "contaminants" mean particles and/or other substances that generally may not be considered to be particles but may be harmful to breathe (e.g., organic vapors);

[0015] "dielectric" means nonconductive to direct electric current;

[0016] "electret" means a dielectric article that exhibits at least quasi-permanent electric charge;

[0017] "electric charge" means that there is charge separation;

[0018] "fibrous" means possessing fibers and possibly other ingredients;

- [0019] "fibrous electret web" refers to a woven or nonwoven web that contains fibers and that possesses at least quasi-permanent electric charge;
- [0020] "fluorinating" means placing fluorine atoms onto the surface of an article;
- [0021] "fluorine-containing species" means molecules and moieties containing fluorine atoms including, e.g., fluorine atoms, elemental fluorine, and fluorine containing radicals;
- [0022] "nonconductive" means possessing a volume resistivity greater than about  $10^{14}$  ohm-cm at room temperature (22 °C);
- [0023] "nonwoven" means a structure or portion of a structure in which the fibers or other structural components are held together by a means other than weaving;
- [0024] "persistent electric charge" means that the electric charge resides in the electret article for at least the commonly-accepted useful life of the product in which the electret article is employed;
- [0025] "polymer" means an organic material that contains repeating linked molecular units or groups that are regularly or irregularly arranged;
- [0026] "polymeric" means containing a polymer and possibly other ingredients;
- [0027] "polymeric fiber-forming material" means a composition that contains a polymer, or that contains monomers capable of producing a polymer, and possibly contains other ingredients, and that is capable of being formed into solid fibers;
- [0028] "quasi-permanent" means that the electric charge resides in the article under ambient atmospheric conditions (22 °C, 101,300 Pascals (Pa) atmospheric pressure, and 50% humidity) for a time period long enough to be significantly measurable;
- [0029] "staple fiber" refers to fibers that are cut to a generally defined length, typically about 2 centimeters to about 25 centimeters and typically has fiber diameter of at least 15 micrometers;
- [0030] "surface fluorination" means the presence of fluorine atoms on a surface (e.g., the surface of a polymeric article);
- [0031] "surface modified" means that the chemical structure at the surface has been altered from its original state;
- [0032] "thermoplastic" means a polymeric material that softens when exposed to heat and that hardens again when cooled without undergoing appreciable chemical change; and

[0033] "web" means a structure that is significantly larger in two dimensions than in a third and that is air permeable.

BRIEF DESCRIPTION OF THE DRAWINGS

[0034] FIG. 1 is a perspective view of a disposable respiratory mask **10** that may use electret filter media of the present invention;

[0035] FIG. 2 is a cross-sectional view of the body **12** of the respiratory mask **10** shown in FIG. 1;

[0036] FIG. 3 is a perspective view of a respiratory mask **24** that has a filter cartridge **28** that may include electret filter media of the present invention; and

[0037] FIG. 4 is a perspective view of a filtration media array **40** of the present invention;

[0038] FIG. 5 is an illustration of ToF-SIMS spectrum for a fluorinated BMF web that highlights a  $C_4F_9^-$  species; and

[0039] FIG. 6 is a chart that shows Q9 values plotted against fluorosaturation ratios for examples 1-8.

DETAILED DESCRIPTION OF THE PREFERRED EMBODIMENTS

[0040] In describing preferred embodiments of the invention, specific terminology is used for the sake of clarity. The invention, however, is not intended to be limited to the specific terms so selected, and it is to be understood that each term so selected includes all technical equivalents that operate similarly.

[0041] Webs suitable for use in this invention can be made from a variety of techniques, including air laid processes, wet laid processes, hydro-entanglement, spun-bond processes, and melt blown processes — see Van A. Wentz, *Superfine Thermoplastic Fibers*, 48 INDUS. ENGN. CHEM. 1342-46 and in Report No. 4364 of the Naval Research Laboratories, published May 25, 1954, entitled *Manufacture of Super Fine Organic Fibers* by Van A. Wentz et al. Webs made using combinations of these techniques and from combinations of such fibers may be used as well. Microfibers, particularly meltblown microfibers, are particularly suitable for use in fibrous webs that are used as filters. As used in this document, "microfiber" means fiber(s) that have an effective diameter of about 25 micrometers or less. Effective fiber diameter can be calculated using equation

number 12 in Davies, C.N., *The Separation of Airborne Dust and Particles*, INST. MECH. ENGN., LONDON PROC. 1B (1952). For filtering applications, the microfibers typically have an effective fiber diameter of less than 20 micrometers, more typically, about 1 to about 10 micrometers. Fibers made from fibrillated films may also be used — see, for example, U.S. Patents RE30,782, RE32,171, 3,998,916, and 4,178,157 to Van Turnout.

[0042] Staple fibers also may be combined with the microfibers to improve web loft, that is, to reduce its density. Reducing web density can lower the pressure drop across the web, making it easier for air to pass through the filter. Lower pressure drops are particularly desirable in personal respiratory protection devices because they make the respirator more comfortable to wear. When the pressure drop is lower, less energy is needed to draw air through the filter. A respirator wearer who dons a negative pressure mask — that is a respirator that requires negative pressure from the wearer's lungs to draw air through the filter — thus does not have to work as hard to breath filtered air. Lower energy requirements also can be beneficial in powered filtering systems to reduce costs associated with powering the fan and to extend the service life of a battery in a battery powered system. In a typical nonwoven fibrous filter, no more than about 90 weight percent staple fibers are present, more typically no more than about 70 weight percent. Typically, the remainder of the fibers are microfibers. Examples of webs that contain staple fibers are disclosed in U.S. Patent 4,118,531 to Hauser.

[0043] Active particulate also may be included in the electret webs for various purposes, including sorbent purposes, catalytic purposes, and others. U.S. Patent 5,696,199 to Senkus et al., for example, describes various types of active particulate that may be suitable. Active particulate that has sorptive properties — such as activated carbon or alumina — may be included in the web to remove organic vapors during filtration operations. The active particulate may be present in the web at amounts up to about 95 volume percent. Examples of particle-loaded nonwoven webs are described, for example, in U.S. Patents 3,971,373 to Braun, 4,100,324 to Anderson, and 4,429,001 to Kolpin et al.

[0044] Polymers that may be suitable for use in producing electret articles include thermoplastic organic nonconductive polymers. These polymers are generally capable of retaining a high quantity of trapped charge and are capable of being processed into fibers, such as through a melt-blowing apparatus or a spun-bonding apparatus. The term



"organic" means that the backbone of the polymer includes carbon atoms. Preferred polymers include polyolefins, such as polypropylene, poly-4-methyl-1-pentene, blends or copolymers containing one or more of these polymers, and combinations of these polymers. Other polymers may include polyethylene, other polyolefins, polyvinylchlorides, polystyrenes, polycarbonates, polyethylene terephthalate, other polyesters, and combinations of these polymers and optionally other nonconductive polymers may be used as polymeric fiber-forming material or for producing other electret articles.

**[0045]** The polymeric electret articles, particularly fibers, also may be extruded or otherwise formed to have multiple polymer components — see U.S. Patent 4,729,371 to Krueger and Dyrud and U.S. Patents 4,795,668, and 4,547,420 to Krueger and Meyer. The different polymer components may be arranged concentrically or longitudinally along the length of the fiber to create, for example, a bicomponent fiber. The fibers may be arranged to form a "macroscopically homogeneous" web, namely, a web that is made from fibers that each have the same general composition.

**[0046]** Fibers may be made from these polymers in conjunction with other suitable additives. Possible additives are thermally stable organic triazine compounds or oligomers, which compounds or oligomers contain at least one nitrogen atom in addition to those in the triazine ring — see U.S. Patents 6,268,495, 5,976,208, 5,968,635, 5,919,847, and 5,908,598 to Rousseau et al. Another additive known to enhance electrets charged by jets of water is Chimassorb™ 944 LF (poly[[6-(1,1,3,3,-tetramethylbutyl) amino]-s-triazine-2,4-diy]][(2,2,6,6-tetramethyl-4-piperidyl) imino] hexamethylene [(2,2,6,6-tetramethyl-4-piperidyl) imino]), available from Ciba-Geigy Corp.

**[0047]** The fibers used in the invention do not need to contain ionomers — particularly metal ion neutralized copolymers of ethylene and acrylic or methacrylic acid or both — to produce a fibrous product suitable for filtration applications. Nonwoven fibrous electret webs can be suitably produced from the polymers described above without containing 5 to 25 weight percent (meth)acrylic acid with acid groups partially neutralized with metal ions.

**[0048]** Fibers that contain additives can be quenched after shaping a heated molten blend of the polymer and additive — followed by annealing and charging steps — to

create an electret article. Enhanced filtration performance may be imparted to the article by making the electret in this manner — see U.S. Patent 6,068,799 to Rousseau et al. The electret articles also can be made to have a low level of extractable hydrocarbon (<3.0 weight %) to improve loading performance — see U.S. Patent 6,776,951 to Rousseau et al.

**[0049]** The polymeric material that is used to produce an electret article according to the invention preferably has a volume resistivity of  $10^{14}$  ohm-cm or greater at room temperature. More preferably, the volume resistivity is about  $10^{16}$  ohm-cm or greater. Resistivity of the polymeric fiber-forming material can be measured according to standardized test ASTM D 257-93. The polymeric fiber-forming material used to make electret articles such as the melt blown fibers also should be substantially free from components such as antistatic agents, which agents could increase the electrical conductivity or otherwise interfere with the ability of the electret article to accept and hold electrostatic charges.

**[0050]** Electrets that comprise a nonwoven polymeric fibrous webs for respiratory filters typically have a "basis weight" in the range of about 2 to 500 grams per square meter ( $\text{g/m}^2$ ), more typically about 20 to 150  $\text{g/m}^2$ . The basis weight is the mass per unit area of filter web. The thickness of such nonwoven polymeric fibrous web is typically about 0.25 to 20 millimeters (mm), more preferably about 0.5 to 2 mm. Multiple layers of fibrous electret webs are commonly used in filter elements. The solidity of the fibrous electret web is typically about 1 to 25, more typically about 3 to 10.

**[0051]** The inventive electret articles may be used as filters in filtering masks that are adapted to cover at least the nose and mouth of a wearer.

**[0052]** FIG. 1 illustrates an example of a filtering face mask **10** that may be constructed to contain an electrically-charged nonwoven web that is produced according to the present invention. The generally cup-shaped body portion **12** is adapted to fit over the nose and mouth of the wearer. The body portion **12** is porous so that inhaled air can pass through it. The electret filter media is disposed in the mask body **12** (typically over substantially the whole surface area) to remove contaminants from the inhaled air. A conformable nose clip **13** may be placed on the mask body to assist in maintaining a snug fit over the wearer's nose. The nose clip can be an "M-shaped" clip as described in U.S. Patents Des. 412,573 and 5,558,089 to Castiglione. A strap or harness system **14** may be provided to support the

mask body **12** on the wearer's face. Although a dual strap system is illustrated in FIG. 1, the harness **14** may employ only one strap **16**, and it may come in a variety of other configurations — see, for example, U.S. Patent 4,827,924 to Japuntich et al., 5,237,986 to Seppalla et al., and 5,464,010 to Byram. An exhalation valve can be mounted to the mask body to rapidly purge exhaled air from the mask interior — see U.S. Patents 5,325,892, 5,509,436, 6,843,248, and 6,854,463 to Japuntich et al.; see also U.S. Patent RE37,974 to Bowers.

**[0053]** FIG. 2 illustrates an example of a cross-section of a mask body **12**. Mask body **12** may have a plurality of layers, as indicated by numerals **18**, **20**, and **22**. The electret filter media may be supported by other layers, such as shaping layers that are made from thermally bonded fibers, such as bicomponent fibers that have an outer thermoplastic component that enables the fibers to bond to other fibers at points of fiber intersection. Layer **18** can be an outer shaping layer, layer **20** may be a filtration layer, and layer **22** may be an inner shaping layer. Shaping layers **18** and **22** support filtration layer **20** and provide shape to mask body **12**. Although the term "shaping layers" is used in this description, shaping layers also have other functions, which in the case of an outermost layer may even be a primary function, such as protection of the filtration layer and prefiltration of a gaseous stream. Also, although the term "layer" is used, one layer may in fact comprise several sublayers, assembled to obtain desired thickness or weight. In some embodiments only one, generally inner, shaping layer is included in a face mask, but shaping may be accomplished more durably and conveniently if two shaping layers are used, for example, one on each side of the filtration layer as shown in FIG. 2. Shaping layer examples are described in the following patents: U.S. Patent 4,536,440 to Berg, 4,807,619 to Dyrud et al., 5,307,796 to Kronzer et al., 5,374,458 to Burgio, and 4,850,347 to Skov. Although the illustrated mask body shown in FIGs. 1 and 2 has a generally round, cup-shaped configuration, the mask body may have other shapes — see for example U.S. Patent 4,883,547 to Japuntich.

**[0054]** FIG. 3 illustrates another respirator **24** that may use the inventive electret articles as a filter. Respirator **24** includes an elastomeric mask body **26** that has a filter cartridge **28** secured to it. Mask body **26** typically includes an elastomeric face piece **30** that conformably fits over the nose and mouth of a person. The filter cartridge **28** may contain

the inventive electret filter media for capturing contaminants before they are inhaled by the wearer. The filter element may include the polymeric electret filter article of the invention by itself or in conjunction with a gaseous filter such as an activated carbon bed. A porous cover or screen 32 may be provided on the filter cartridge to protect the external surface of the filter element. Examples of other filter cartridges where the inventive electret filter media may be used are disclosed, for example, in a filter cartridge for a respirator, such as the filter cartridge disclosed in U.S. Patent No. Re. 35,062 to Brostrom et al. or in U.S. Patent 5,062,421 to Burns and Reischel. As shown in these patents, multiple filter cartridges may be used. The cartridges also may be removable and replaceable. In addition, the inventive filter media may be used in the filter cartridges of powered air purifying respirators (PAPRs). Examples of PAPRs are shown in U.S. Patents 6,666,209 to Bennett et al. and 6,575,165 to Cook et al. Further, the inventive filter media can be used in filter cartridges for escape hoods — see U.S. Patent D480,476 to Martinson et al., and 6,302,103, 6,371,116, 6,701,925 to Resnick.

[0055] FIG. 4 shows a perspective view of a filtration media array 40. The structure of array 40 may comprise multiple flow channels 42 that define inlets 43 on a first side 44 of the array 40 and have outlets 46 on a second side of the array 48. The flow channels may be defined by a corrugated or microstructured layer 50 and a cap layer 52. The contoured layer 50 may be joined to the cap layer 52 at one or more peaks or valleys. By stacking multiple layers of structured and planar members, a microchanneled arrangement may be achieved. The flow channels tend to have a high aspect ratio, and the film layers are preferably electrically charged to provide the article 40 with good capture efficiency. The pressure drop across the array 40 from first side 44 to second side 48 is negligible.

[0056] Non-fibrous electret articles that are used for filtration purposes thus may take the form of a shaped film, a microstructured surface, or a multitude of microstructured channels. Examples of non-fibrous electret articles are disclosed in U.S. Patent 6,752,889 to Insley et al., 6,280,824 to Insley et al., 4,016,375 to Van Turnout, and 2,204,705 to Rutherford.

#### Fluorinating

[0057] The inventive fluorinated electrets can be prepared by transferring fluorine containing species from a gaseous phase to the article by chemical reaction, sorption,

condensation, or other suitable means. The polymeric article can be fluorinated, optionally in the presence of a surface modifying electrical discharge, followed by charging the article to produce the fluorinated electret. Alternatively, the inventive articles can be charged first and then fluorinated.

**[0058]** The surface of the polymeric article can be modified to contain fluorine atoms by exposing the polymeric article to an atmosphere that includes fluorine containing species. The fluorination process can be performed at atmospheric pressure, less than atmospheric pressure, or under "reduced pressure". The fluorination process is preferably performed in a controlled atmosphere to prevent contaminants from interfering with the addition of fluorine atoms to the surface of the article. The term "controlled" means the apparatus has the ability to control the composition of the atmosphere in the chamber where fluorination occurs. The atmosphere preferably is substantially free of oxygen and other undesired components. The atmosphere typically contains less than 1 % oxygen or other undesired components, preferably less than 0.1%, by volume.

**[0059]** The fluorine containing species present in the atmosphere can be derived from fluorinated compounds that are gases at room temperature, that become gases when heated, or that are capable of being vaporized. Examples of useful sources of fluorine-containing species include fluorine atoms, elemental fluorine, inorganic fluorides such as fluorinated sulfur (e.g., SF<sub>6</sub>), fluorinated nitrogen (e.g., NF<sub>3</sub>), and PF<sub>3</sub>, BF<sub>3</sub>, SiF<sub>4</sub>, and combinations thereof. The atmosphere of fluorine containing species can also include inert diluent gases such as the noble gases helium, argon, etc, and combinations thereof. Nitrogen can also be used as a diluent.

**[0060]** The electrical discharge that is applied during the fluorination process is capable of modifying the surface chemistry of the polymeric article when applied in the presence of a source of fluorine containing species. The electrical discharge may be in the form of plasma, e.g., glow discharge plasma, corona plasma, silent discharge plasma (also referred to as dielectric barrier discharge plasma and alternating current ("AC") corona discharge), and hybrid plasma, e.g., glow discharge plasma at atmospheric pressure, and pseudo glow discharge — see U.S. Patents 6,808,551, 6,660,210, 6,562,112, 6,432,175, 6,409,806, 6,398,847 and 6,397,458 to Jones/Lyons et al. Preferably, the plasma is an AC plasma at reduced pressure. "Reduced pressure" means pressure less than 700 Pa,

preferably less than 140 Pa. Examples of useful surface modifying electrical discharge processes are described in U.S. Patents 5,244,780, 4,828,871, and 4,844,979 to Strobel et al.

**[0061]** Another fluorination process may include immersing a polymeric article in a liquid that is inert with respect to elemental fluorine, and bubbling elemental fluorine gas through the liquid to produce a surface fluorinated article. Examples of useful liquids that are inert with respect to fluorine include perhalogenated liquids, e.g., perfluorinated liquids such as Performance Fluid PF 5052 (commercially available from the 3M Company). The elemental fluorine containing gas that is bubbled through the liquid can include an inert gas such as, e.g., nitrogen, argon, helium, and combinations thereof.

**[0062]** The higher the Q9 value, at a given flow rate, the better the filtering performance of the electret after high-temperature storage. Preferred electrets have a Q9 value of at least about 1.4/mmH<sub>2</sub>O, preferably at least about 1.5/mmH<sub>2</sub>O, more preferably at least about 2.0/mmH<sub>2</sub>O. Q9 values may be determined according to the test set forth below. Higher thermally stimulated discharge current (TSDC) values, which also correspond to higher thermal stability, may be achieved by this invention. Preferred electrets that contain polypropylene have a TSDC peak value of greater than 130°C, more preferably, greater than 140°C.

**[0063]** The fluorine surface concentration may be ascertained using electron spectroscopy for chemical analysis (ESCA), also known as X-ray photoelectron spectroscopy or XPS. The surface of the inventive electret articles exhibits about 45 to 60 atomic % fluorine when analyzed by XPS. XPS analyzes the elemental composition of the outermost surface (i.e., approximately 30 to 100 Å) of a specimen. The ratio of CF<sub>3</sub> to CF<sub>2</sub> on the inventive articles is at least about 0.15, preferably at least about 0.2, and more preferably is at least about 0.3. At the upper end, the CF<sub>3</sub>:CF<sub>2</sub> ratio is typically less than about 0.7 or 0.6. The ratio of CF<sub>3</sub> to CF<sub>2</sub> may be determined using the x-ray photoelectron spectroscopy (XPS) method described below.

**[0064]** The electret also has a fluorosaturation ratio (FSR) at the surface of the electret of greater than about 200, preferably greater than about 250, and may be greater than about 300. The fluorosaturation ratio, FSR, can be determined by dividing the atomic percent fluorine of a sample by its saturated/unsaturated ratio. The atomic percent fluorine and the

saturated/unsaturated ratio may be determined using XPS and ToF-SIMS procedures described below. Better Q9 values are generally achieved at higher fluorosaturation ratios (see FIG. 6), and thus the higher the FSR the better the higher temperature oily mist performance. FSR values of 350 or even as high as 500 may be achieved.

[0065] To achieve the fluorosaturation ratio of the present invention, the electret articles preferably are prepared (fluorinated) in a system that is evacuated to a pressure below about 4 Pascals and is refilled with a continuous feed of the intended fluorinating atmosphere while controlling the pumping rate to achieve a desired working pressure. The inventors discovered that it is convenient to carry out the fluorination step under a reduced pressure using an AC powered discharge.

#### Imparting Electrical Charge

[0066] The electret charge can be imparted to the polymeric articles using various methods. Polymeric materials can be bombarded with electric particles when they are extruded from the die orifice as taught in U.S. Patent 4,215,682 to Kubik et al. Alternatively, DC corona charging has been used as described in U.S. Patents RE 30,782; 31,285 and 32,171 to van Turnhout, and U.S. Patents 4,375,718 and 5,401,446 to Wadsworth et al., U.S. Patent 4,588,537 to Klasse et al., and U.S. Patent 4,592,815 to Nakao. The polymeric articles also can be charged by contacting them with water or a polar liquid. Documents that describe charging through use of water — that is hydrocharging — include U.S. Patents 5,496,507, 6,119,691, 6,375,886, and 6,783,574 to Angadjivand et al., U.S. Patent 6,406,657 to Eitzman et al., and U.S. Patent 6,743,464 to Insley et al. Electret articles also can be charged by exposing them to polar liquids other than water as taught in U.S. Patent 6,454,986 to Eitzman et al. Hydrocharging is a preferred method for imparting charge to the fibers because it uses a readily available material that is easy to handle and that is environmentally friendly. Hydrocharging also provides higher Q9 values when used in conjunction with the present invention. The charging process can be applied to one or more surfaces of the article.

[0067] Hydrocharging methods deposit both positive and negative charge onto the fibers such that the positive and negative charge is randomly dispersed throughout the web. Random charge dispersal tends to produce an unpolarized web. Thus, a nonwoven fibrous electret web produced by charging with a polar liquid like water may be

substantially unpolarized in a plane normal to the plane of the web. Fibers that have been charged in this manner ideally exhibit the charge configuration shown in Figures 5C of U.S. Patent 6,119,691 to Angadjivand et al. If the fibrous web also is subjected to a corona charging operation, it would exhibit a charge configuration similar to the configuration shown in Figure 5B of that patent. A web, formed from fibers charged solely using hydrocharging, typically has unpolarized trapped charge throughout the volume of the web. "Substantially unpolarized trapped charge" refers to a fibrous electret web that exhibits less than  $1 \mu\text{C}/\text{m}^2$  of detectable discharge current using thermally-simulated discharge current (TSDC) analysis, where the denominator is the electrode surface area. This charge configuration can be shown by subjecting the web to TSDC. One example of a useful hydrocharging process includes impinging jets of water or a stream of water droplets onto the article at a pressure and for a period sufficient to impart a filtration enhancing electret charge to the web, and then drying the article — see U.S. Patent No. 5,496,507 to Angadjivand et al. The pressure necessary to optimize the filtration enhancing electret charge imparted to the article will vary depending on the type of sprayer used, the type of polymer from which the article is formed, the type and concentration of additives to the polymer, and the thickness and density of the article. Pressures in the range of about 10 to about 500 psi (69 to 3450 kPa) are suitable. The jets of water or stream of water droplets can be provided by any suitable spray device. One example of a useful spray device is the apparatus used for hydraulically entangling fibers.

[0068] The fluorinated electrets formed by the methods described in this document are suitable for use as, e.g., electrostatic elements in electro-acoustic devices such as microphones, headphones and speakers, fluid filters, dust particle control devices in, e.g., high voltage electrostatic generators, electrostatic recorders, respirators (e.g., prefilters, canisters and replaceable cartridges), heating, ventilation, air conditioning, and face masks.

#### Method for Determining Surface Concentration of Fluorine and $\text{CF}_3:\text{CF}_2$ Using X-ray Photoelectron Spectroscopy (XPS)

[0069] X-ray photoelectron spectroscopy (XPS) is a surface analysis technique that uses a beam of soft x-rays ( $\text{Al K}\alpha$ , 1486.6 eV) as a probe. The x-rays irradiate the material to generate photoelectrons that are characterized by their kinetic energy and intensity. The kinetic energies of the photoelectrons can provide quantitative information of the elements



and their chemical states. XPS probes the outermost  $\sim 30$  to  $100 \text{ \AA}$  of a sample surface. It is sensitive to essentially all elements except hydrogen and helium, with detection limits down to approximately 0.1 atomic %.

[0070] XPS measurements were carried out on the sample materials using a Kratos Axis Ultra Spectrometer (Kratos Analytical, Manchester, England), which spectrometer was equipped with a monochromatic Al  $K\alpha$  x-ray excitation source and a spherical mirror analyzer. The spectrometer had an X-ray power equal to or near 168 Watts (W) (14kV, 12mA). The photoelectron take-off angle for all recorded spectra was 90 degrees, measured with respect to the sample surface. The Kratos system has a sampling area of approximately 800 micrometers ( $\mu\text{m}$ )  $\times$  600  $\mu\text{m}$ . The pressure in the vacuum system during analysis was at or below  $7.0 \times 10^{-6}$  Pascals (Pa).

[0071] Using the XPS method, wide scan surveys were obtained from the sample materials. A wide scan survey spectrum contains photoelectron peaks that are characteristic of the elements present on the surface of the material. The surface composition (in atomic %) is derived from the relative areas of the core-level photoelectron peaks, with linear background subtractions and corrections to account for the instrument's atomic sensitivity factors. The Kratos spectrometer's performance was verified by analysis of a poly(tetrafluoroethylene) (PTFE) sample, which showed experimental values of atomic % fluorine (APF) = 67 and atomic % carbon = 33. These values are in excellent agreement with the PTFE theoretical stoichiometry.

[0072] A narrow scan of the carbon 1s (C 1s) spectrum was also obtained. The C 1s spectrum provides chemical information regarding the specific type of carbon bonding functionality that is present. The carbon 1s envelope consists of several peak components, which include peaks from an unfunctionalized carbon, and carbon bonded to fluorine atom(s). The charging of the insulating samples was corrected using a common convention, which is to put the unfunctionalized carbon component at 285.0 eV. After the charge correction, the peak near 294 eV was attributed to the  $-\text{CF}_3$  peak while the peak centered near 292 eV was attributed to the  $-\text{CF}_2-$  functionality. These peak assignments are well documented in the literature.

[0073] Analysis of the carbon 1s spectra required that each spectrum be processed using a curve fitting procedure. Here, the curve fitting procedure was performed using the

Vision Data Software Package from Kratos Analytical. The peak shape, used for all curve fits, is a Gaussian(70%)-Lorentzian(30%) peak shape model, GL(30). The carbon 1s envelope was resolved into 6 components. The  $CF_3/CF_2$  values reported here are ratios of calculated areas from the  $-CF_3$  and  $-CF_2$ - peaks fitted with GL(30) curves.

[0074] Typical survey and carbon 1s instrumental settings that were used to obtain the survey and carbon 1s spectra are given in Table 1 below:

**Table 1**

Analysis	Pass Energy (eV)	Scan Length (eV)	eV/data point (eV)	Time/data point (ms)	Number of Sweeps
Survey	160	0 to 1100	0.5	55	6
C 1s	20	275 to 300	0.1	390	8

Method for Determining Saturated/Unsaturated Ratio Using ToF-SIMS:

[0075] Time-of-flight secondary ion mass spectrometry (ToF-SIMS) is a surface analysis technique in which a pulsed beam of kilovolt energy ions (primary ions) is used to bombard a specimen, resulting in sputtering of its surface. During sputtering, neutral and ionized atomic and molecular species are emitted from the surface. The ionized species are referred to as "secondary ions" to distinguish them from the bombarding primary ions. Secondary ions of one polarity are accelerated in an electric field to a mass spectrometer, where they travel through a flight tube and arrive at the detection and counting system. As a result of the fragments departing from the sample surface at the same time, and being subject to the same accelerating voltage, the lighter fragments arrive at the detection system before the heavier ones. The "time-of-flight" of a fragment is proportional to the square root of its mass, so that different masses are separated during the flight and can be detected individually. The quantity measured in the analysis is the fragment mass divided by the charge amount on the fragment ( $m/z$ ).

[0076] ToF-SIMS analysis was performed on samples using a Physical Electronics Trift I instrument (Eden Prairie, Minnesota), with a 15 kilovolt (keV)  $Ga^+$  primary ion beam rastered over a  $400\ \mu m \times 400\ \mu m$  sample target area. ToF-SIMS provides chemical information on the outermost 10 to 20 Å of a material and produces spectra of fluorocarbon ions in both the positive and negative ion modes, extending out to a mass of 1000 atomic mass units (u) and beyond. Analysis of negative ion spectra of  $C_3F_8$ -fluorinated webs

showed that the fluorocarbon ions could be separated into distinct oligomeric series, ranging from completely saturated to highly unsaturated. The more prominent series are as follows:

$C_nF_{2n+1}^-$ , where  $n = 1, 2, \dots$  fully saturated series (examples:  $C_4F_9^-$ ,  $C_8F_{17}^-$ )

$C_nF_{2n-1}^-$ , where  $n = 3, 4, \dots$  unsaturated series (examples:  $C_4F_7^-$ ,  $C_8F_{15}^-$ )

$C_nF_{2n-3}^-$ , where  $n = 6, 7, \dots$  unsaturated series (examples:  $C_7F_{11}^-$ ,  $C_8F_{13}^-$ )

$C_nF_{2n-5}^-$ , where  $n = 8, 9, \dots$  highly unsaturated series (examples:  $C_8F_{11}^-$ ,  $C_{10}F_{15}^-$ )

Generally, these ion series each show an intensity distribution that tends to tail off at a higher mass. Unsaturated ion series are largely indicative of direct sample fluorination, while the unsaturated ion series above  $n = 3$  are indicative of a highly branched fluoropolymer coating deposited on the sample.

[0077] The saturated/unsaturated ratio (SUR) is calculated using the following equation:

$$SUR = C_s / C_u \quad (\text{dimensionless})$$

Given:

$$C_s = \sum_{n=4}^8 C_n F_{2n+1} \quad \text{Saturated Ion Count}$$

$$C_u = \sum_{n=4}^8 C_n F_{2n-1} + \sum_{n=6}^9 C_n F_{2n-3} + \sum_{n=8}^{10} C_n F_{2n-5} \quad \text{Unsaturated Ion Count}$$

Values of " $C_xF_y$ " are counts of ions for a given structure at the spectra locations specified in Table 2 below:

TABLE 2

Ion Structure	Spectrum Nominal Mass (m/z)	Spectrum Lower Mass (m/z)	Spectrum Upper Mass (m/z)
C <sub>4</sub> F <sub>9</sub>	219	218.329	219.953
C <sub>5</sub> F <sub>11</sub>	269	268.146	270.036
C <sub>6</sub> F <sub>13</sub>	319	318.218	319.981
C <sub>7</sub> F <sub>15</sub>	369	368.174	369.953
C <sub>8</sub> F <sub>17</sub>	419	418.146	419.942
C <sub>4</sub> F <sub>7</sub>	181	180.356	181.87
C <sub>5</sub> F <sub>9</sub>	231	230.312	231.843
C <sub>6</sub> F <sub>11</sub>	281	280.191	281.887
C <sub>7</sub> F <sub>13</sub>	331	330.218	331.87
C <sub>8</sub> F <sub>15</sub>	381	380.312	381.887
C <sub>6</sub> F <sub>9</sub>	243	242.191	243.887
C <sub>7</sub> F <sub>11</sub>	293	292.174	293.942
C <sub>8</sub> F <sub>13</sub>	343	342.202	343.925
C <sub>9</sub> F <sub>15</sub>	393	392.174	393.942
C <sub>8</sub> F <sub>11</sub>	305	304.163	305.914
C <sub>9</sub> F <sub>13</sub>	355	354.191	355.87
C <sub>10</sub> F <sub>15</sub>	405	404.229	405.831

[0078] As an illustration of the spectra type, FIG. 5 shows a ToF-SIMS spectrum for a fluorinated polypropylene blown microfiber (BMF), more specifically, the spectrum record for a C<sub>4</sub>F<sub>9</sub><sup>-</sup> ion species. The plots progressively provide a magnification that centers around the C<sub>4</sub>F<sub>9</sub><sup>-</sup> ion at a m/z of 219. As is indicated in the bottom plot, the ion count for the C<sub>4</sub>F<sub>9</sub><sup>-</sup> species in the defined range between m/z 218.329 and m/z 219.953, was 1520. This would be the count value used in the calculation of the saturated/unsaturated ratio (SUR). In this manner counts for saturated and unsaturated species were made for input to the SUR calculation for a given Example.

#### Fluorosaturation Ratio

[0079] The fluorosaturation ratio (FSR) is a calculated value determined by dividing the atomic % fluorine (APF) of a sample by its saturated/unsaturated ratio (SUR) and is given as:

$$FSR = APF / SUR$$

Thermally Stimulated Discharge Current (TSDC)

[0080] Thermally Stimulated Discharge Current (TSDC) studies were conducted using a Solomat TSC/RMA model 91000 with a pivot electrode, available from TherMold Partners, L.P., Thermal Analysis Instruments of Stamford, Conn. Test samples were prepared by first exposing them to a DC corona charge to polarize the previously substantially unpolarized trapped charge. DC corona charging was carried out under ambient conditions using a horizontally arranged series of four charging bars (obtained under the trade designation "CHARGEMASTER PINNER ARC RESISTANT CHARGING BAR" from Simco Company, Hatfield, Pennsylvania). Charging bars were spaced with a center-to-center distance between bars 1 and 2, 2 and 3, and 3 and 4 of 7.6 cm, 8.3 cm, and 9.5 cm respectively. Each charging bar was situated 3.5 cm above a corresponding grounded metal plate. A voltage of + 29 kilovolts (relative to the grounded metal plates) was applied to each charging bar. Samples were charged by placing them on a moving (2.54 cm/sec) continuous belt (part number 8882802A, obtained from Light Weight Belting Corporation, Minneapolis, Minnesota) that passed between the charging bars and the metal plates, such that the belt maintained contact with the metal plates.

[0081] To determine the TSDC, corona treated web samples were placed between electrodes in the Solomat TSC/RMA test instrument. In the Solomat instrument, a thermometer was disposed adjacent to, but not touching, the sample to record the temperature at discharge. The web samples were optically dense, that is, there were no visible holes through the sample web. Samples were also large enough to completely cover the top contact electrode of the Solomat instrument. To ensure good electrical contact to the electrodes, the web samples were compressed in thickness by about a factor of 10. With the sample fixtured in the instrument, air was purged from the sample chamber using helium at a pressure of about 110 kPa. Liquid nitrogen cooling was used to cool the chamber to a temperature of about 5 °C.

[0082] During the test procedure a sample was held at 5 °C for 5 minutes with the field off and then heated at 5 °C/min while the discharge current was measured. Charge densities can be calculated from each TSDC spectrum peak by drawing a baseline between the minima on each side of a selected peak and integrating the area under the peak. The

peak maximum is defined as the temperature at which the discharge current obtains a maximum value.

#### Thermal Stability Quality Factor (Q9)

[0083] Thermal stability Quality Factor (Q9) was determined for a test sample by first conditioning the sample in an oven for nine hours at 100°C. The conditioned sample was allowed to cool and was tested for particle penetration. Q9 is a calculated value that is based on the measure of the particle penetration of small particles of dioctyl phthalate (DOP) as they are filtered through the test sample. Particle penetration was determined using a CertiTest, automated filter tester, from TSI Inc., St Paul MN. Flow rate of the instrument was set at 42.5 liter/minute (L/min), which corresponded to a face velocity of 6.9 centimeters per second (cm/sec). The particle neutralizer of the system was turned off. Pressure drop across the sample was measured at the challenge face velocity of 6.9 cm/sec using an electronic manometer. Pressure drop was reported in millimeters of water (mm H<sub>2</sub>O). DOP penetration and pressure drop are used to calculate Q9 from the natural log (ln) of the DOP penetration under the following formula:

$$Q9[1/mm H_2 O] = \frac{-\ln\left(\frac{DOPPenetration(\%)}{100\%}\right)}{PressureDrop[mm H_2 O]}$$

A higher Q9 value indicates better filtration performance after heat conditioning. A lower Q9 effectively correlates with decreased filtration performance upon heat exposure.

#### Effective Fiber Diameter

[0084] The average Effective Fiber Diameter (EFD) of a web sample in micrometers was calculated using equation number 12 and an air flow rate of 32 L/min according to the method described in Davies, C. N., *The Separation of Airborne Dust and Particles*, Institution of Mechanical Engineers, London, *Proceedings* 1B, 1952.

#### Web Solidity

[0085] Web solidity was determined by dividing the bulk density of a web by the density of the materials making up the web. Bulk density is the basis weight of a web

(ratio of web weight to its surface area) divided by its thickness. Bulk density of a web was determined by measuring the weight and thickness of a known area of web. Thickness of the web was determined by placing a web sample on a flat support and then lowering a plate (9.81 cm diameter, 230 g) onto the sample at a loading pressure of 298 Pascals. With the sample loaded, the distance between the plate and flat support were measured. Dividing the web sample weight by the sample area gave the basis weight (BW) of the specimen, which is reported in grams per square centimeter ( $\text{g}/\text{cm}^2$ ). The bulk density was determined by dividing the web basis weight by its thickness and was reported in grams per cubic centimeter ( $\text{g}/\text{cm}^3$ ). Web solidity ( $S$ ) was determined by dividing the web bulk density by the density of the material from which the web was produced. The density of the polymer or polymer components can be measured by standard means if the supplier does not specify material density. Solidity ( $S$ ) is reported as a dimensionless fraction of the percent solids content of a given specimen and is calculated as follows:

$$S = \frac{\rho_{web}}{\rho_{material}} \times 100\%$$

#### EXAMPLES

[0086] The following Examples have been selected merely to further illustrate features, advantages, and other details of the invention. It is to be expressly understood, however, that while the Examples serve this purpose, the particular ingredients and amounts used as well as other conditions and details are not to be construed in a manner that would unduly limit the scope of this invention.

#### General Web Making, Plasma Treatment, and Electret Charging Procedures

[0087] Blown microfiber (BMF) webs used in the examples were prepared from polypropylene (Fina EOD 97-13 polypropylene resin available from Total Petrochemicals USA, Inc., Houston, Texas) and had effective fiber diameters of approximately  $7.5 \mu\text{m}$ , a basis weight of  $62 \text{ g}/\text{m}^2$ , and a web solidity of 6%. Webs were prepared as generally described in Wentz, Van A., *Superfine Thermoplastic Fibers*, INDUSTRIAL ENG. CHEMISTRY, Vol. 48, pp. 1342-1346.

[0088] BMF webs were plasma treated using one of two methods, denoted as Plasma Treatment Method A or B. These methods are described as follows:

Plasma Treatment Method A

[0089] Webs treated using plasma treatment method "A" were placed in a chamber between two electrode plates spaced 1.3 cm apart. The plates had an active electrode surface area of approximately 900 cm<sup>2</sup>. With the specimen in position, the chamber was sealed and evacuated to a pressure not greater than approximately 3 Pascals (Pa). After evacuation, a gas mixture, at a specified flow rate, was introduced into the gap between the plasma electrodes. A chamber pressure of 67 Pa was maintained. The electrodes within the chamber were then energized using an RF generator (13.56 MHz) coupled through an automatic matching network (RF- 50 and AMN-20-K, RF Plasma Products, Inc., Voorhees NJ) in order to sustain the plasma. The web was exposed to the plasma for a specified time to achieve a desired plasma exposure energy. The residence time of the gas molecules in the treatment chamber was estimated to be about 50 to 60 milliseconds for a pressure of 67 Pa and a flow of 0.024 standard cubic centimeters per minute per square centimeter of sample. Both sides of the web were treated in this manner.

Plasma Treatment Method B

[0090] Webs treated using plasma treatment method "B" were plasma treated in a web conveying process for a specified time using an AC plasma in a vacuum chamber that was filled with 24.7 Pa of fluorine containing species gas at a specified total plasma energy. The molecule residence time in the treatment chamber was estimated to be about 120 seconds for a pressure of 67 Pa and a flow of 0.024 standard cubic centimeters per minute per square centimeter of sample area. The pumping rate was adjusted to control the desired working pressure. A web conveying system moved the specimen through the gap between a set of drum electrodes that had a configuration such that both sides of the substrate were subjected to the plasma. Each side was treated for an equal duration. The drum electrodes consisted of a 6061-aluminum drum surrounded by a concentric 6061-aluminum plate that formed a gap through which the substrate was run. Power was applied using an RF generator (13.56 MHz) coupled through an automatic matching



network (RF- 50 and AMN-20-K, RF Plasma Products, Inc., Voorhees NJ) in order to sustain the plasma. Both sets of electrodes were cooled to 23 °C using recirculating water.

[0091] After plasma treatment, webs were electret-charged in a manner generally described in US Pat. No. 5,496,507, to Angadjivand, et al. Webs were charged using one of two methods, denoted below as Hydrocharging Method A or B.

#### Hydrocharging Method A

[0092] Webs treated using hydrocharging method "A" were passed under spray heads that delivered deionized water, having a resistivity of about  $6 \times 10^6$  ohm-cm, to one web face while a vacuum was applied to the opposite web face. Water was delivered to the webs using Teejet Model 95015 spray heads available from Spraying Systems, Wheaton, IL. Spray heads were placed 10 cm apart and 10.5 cm away from the webs and operated at a pressure of 689 kPa. Water was sprayed at a rate of about 0.87 liters of water per square meter of web. Webs passed under the spray heads at a rate of 15 cm/sec while a vacuum of 8.7 kPa below atmospheric was applied to a slot (about 0.6 cm wide) that was positioned opposite the spray heads under the open mesh carrier belt. Both web sides were treated in this manner. The web was dried in a 71°C oven for about 38 seconds.

#### Hydrocharging Method B

[0093] Webs treated using hydrocharging method "B" were charged using distilled water that had a resistivity of about  $2 \times 10^6$  ohm-cm. Water was sprayed onto the web while it was being conveyed at a speed of 5.1 cm/sec on a porous belt past two spray heads (type Teejet 9501, Spraying Systems, Wheaton, IL). The spray heads were operated at a pressure of 758 kPa and were oriented so that their spray pattern was perpendicular to the direction of web travel. The spray heads were positioned 10 cm apart and 10 cm away from the belt. Located under the conveying belt opposite the spray heads was a vacuum slot, 25 cm long and 0.5 cm wide that was attached to a Dayton Electric wet dry vacuum, model 2Z974B (Dayton Electric, Chicago, IL). Both sides of the web were treated in the described manner. Following water treatment, the webs were dried in ambient conditions for approximately sixteen hours.

**EXAMPLES 1, 2, 3, and 4**

[0094] BMF webs as described in the "General Web Making and Treatment" section were prepared using Plasma Treatment Method B, employing plasmas of various compositions. Plasma treated webs were electret charged using Hydrocharging Method A. Sample preparation conditions — including fluorine containing species gas, fluorine species blend ratio, exposure time, total plasma energy, and gas flow rate — are given in Table 4 with corresponding values for the resulting atomic % fluorine (APF), saturated/unsaturated ratio (SUR), fluorosaturation ratio (FSR), and the thermal stability quality factor (Q9) given in Table 5.

**EXAMPLES 5, 6, 7, 8**

[0095] BMF webs, as described in the "General Web Making and Treatment" section, were prepared using Plasma Treatment Method A and Hydrocharging Method B, employing plasmas of compositions of a gas blend of vol. 5% F<sub>2</sub> and 95% vol. He. After a specified duration of time the chamber was de-energized and purged, and the sample was removed. The sample was then placed back into the chamber with the side treated in the first stage placed down on the energized plate. The process repeated.

[0096] Sample preparation conditions — including fluorine containing species gas, fluorine species blend ratio, total exposure time, and total plasma energy — are given in Table 4 with corresponding values for the resulting atomic % fluorine (APF), saturated/unsaturated ratio (SUR), fluorosaturation ratio (FSR), and the thermal stability quality factor (Q9) given in Table 5.

**COMPARATIVE EXAMPLES 1c, 2c, 3c, 4c, 5c, 6c, 7c, 8c, and 9c**

[0097] BMF webs, as described in the "General Web Making and Treatment" section, were prepared using various gaseous fluorine containing species under Plasma Treatment Method B and Hydrocharging Method A. Sample preparation conditions — including fluorine containing species gas, exposure time, and total plasma energy — are given in Table 4 with corresponding values for the resulting atomic % fluorine (APF), saturated/unsaturated ratio (SUR), fluorosaturation ratio (FSR), and the thermal stability quality factor (Q9) given in Table 5.

**COMPARATIVE EXAMPLES 10c, 11c, 12c, 13c**

[0098] Comparative Examples 10c through 13c were drawn directly from U.S. Pat. No. 6,397,548 (Jones et al) with the examples of the patent correlating to the comparative examples set forth in Table 3. All of these webs were fluorinated at atmospheric pressure with the quoted concentration of Fluorine containing gas diluted in pure helium. Sample preparation conditions — including fluorine containing species gas, exposure time, and total plasma energy — given in Table 4. Values for the resulting atomic % fluorine (APF), saturated/unsaturated ratio (SUR), fluorosaturation ratio (FSR), and the thermal stability quality factor (Q9), where applicable, are shown in Table 5.

**TABLE 3**

Comparative Example	Description	U.S. 6,397,548 Example
10c	1% CF <sub>4</sub> Corona Fluorination	6
11c	1% C <sub>2</sub> F <sub>6</sub> Corona Fluorination	1
12c	0.1% C <sub>3</sub> F <sub>6</sub> Corona Fluorination	27
13c	0.1% C <sub>5</sub> F <sub>12</sub> Corona Fluorination	8

TABLE 4

Example	Fluorine Species	Gas Flow (cm <sup>3</sup> /min/cm <sup>2</sup> )	Exposure Time (seconds)	Total Plasma Energy (J/cm <sup>2</sup> )
1	SF <sub>6</sub>	0.028	120	14.4
2	SF <sub>6</sub>	0.028	75	9.0
3	NF <sub>3</sub>	0.028	120	9.0
4	NF <sub>3</sub>	0.028	75	9.0
5	F <sub>2</sub>	0.2	20	5.6
6	F <sub>2</sub>	0.2	6	1.7
7	F <sub>2</sub>	0.2	36	10.1
8	F <sub>2</sub>	0.12	20	5.6
1c	C <sub>3</sub> F <sub>8</sub>	0.028	120	14.4
2c	C <sub>3</sub> F <sub>8</sub>	0.028	75	9.0
3c	C <sub>3</sub> F <sub>8</sub>	0.028	20	2.4
4c	SF <sub>6</sub>	0.028	20	2.4
5c	NF <sub>3</sub>	0.028	20	2.4
6c	CF <sub>4</sub>	0.028	75	9.0
7c	CF <sub>4</sub>	0.028	20	2.4
8c	SiF <sub>4</sub>	0.028	120	14.4
9c	BF <sub>3</sub>	0.028	120	14.4
10c	CF <sub>4</sub>	NA	NA	NA
11c	C <sub>2</sub> F <sub>6</sub>	NA	NA	NA
12c	C <sub>3</sub> F <sub>6</sub>	NA	NA	NA
13c	C <sub>5</sub> F <sub>12</sub>	NA	NA	NA

NA = Not Available

TABLE 5

Example	SUR (unitless)	APF (%)	FSR (unitless)	Q9 (1/mmH <sub>2</sub> O)	TSDC Peak Temp (°C)	CF <sub>3</sub> /CF <sub>2</sub>
1	0.19	49	258	1.88	142	0.43
2	0.18	47	261	1.90	NA	0.56
3	0.21	53	252	1.75	146	0.41
4	0.22	50	227	1.39	NA	0.39
5	0.20	53	265	1.98	NA	0.35
6	0.17	48	282	2.11	NA	0.36
7	0.16	54	338	1.97	NA	0.3
8	0.19	52	274	2.03	NA	0.35
1c	1.37	57	42	1.36	124	1.27
2c	1.14	55	48	1.25	NA	1.5
3c	1.08	43	40	0.82	NA	2.42
4c	0.34	37	109	1.00	NA	0.43
5c	0.68	37	54	0.78	NA	0.11
6c	0.34	35	103	1.47	122	0.98
7c	0.49	22	45	1.17	NA	0.83
8c	0.59	7.9	13	0.22	NA	*
9c	1.69	1.1	1	0.47	NA	*
10c	0.50	53	106	NA	NA	NA
11c	1.39	56	40	NA	NA	NA
12c	0.75	58	77	NA	NA	NA
13c	2.01	58	29	NA	NA	NA

NA = Not Available

\*Signal not detectable

[0099] As is evident from the Q9 filtration results given in Table 5, fluorinated filter webs of the invention that have greater FSR values achieve a significant thermally stable filtration improvement. Webs with a fluorosaturation ratio (FSR) of 200 or greater achieve improved levels of thermal stability quality factor Q9 over webs with FSR values less than 200.

[00100] FIG. 6 is a plot of the FSR data for Examples 1-8 and shows a general trend of increased Q9 values with higher FSR values.

[00101] Additionally, fluorinated filter webs of the invention that have greater TSDC peak values demonstrate higher thermal stability than webs with lower TSDC values. As shown in Table 5, webs with a TSDC peak value of 130 °C or greater exhibit improved levels of thermal stability quality factor Q9 over webs with TSDC peak values of less than 130 °C.

[00102] An application that also describes a method for achieving a thermally stable electret article is entitled *Electret Article Having Heteroatoms and Low Fluorosaturation Ratio*, filed on the same day as this application (attorney case number 59338US002).

[00103] This invention may take on various modifications and alterations without departing from its spirit and scope. Accordingly, this invention is not limited to the above-described but is to be controlled by the limitations set forth in the following claims and any equivalents thereof.

[00104] This invention also may be suitably practiced in the absence of any element not specifically disclosed herein.

[00105] All patents and patent applications cited above, including those in the Background section, are incorporated by reference into this document in total.

## Claims:

1. An electret article that comprises:  
a polymeric material that has electric charge imparted thereto, that has a  $\text{CF}_3$  to  $\text{CF}_2$  ratio of at least about 0.15, and that has a fluorosaturation ratio greater than about 200.
2. The electret article of claim 1, wherein the polymeric material is nonconductive, and wherein electret article exhibits persistent electric charge.
3. The electret article of claim 2, wherein the polymeric material is in the form of a nonwoven web of fibers.
4. The electret article of claim 3, wherein the fibers are microfibers.
5. The electret article of claim 4, wherein the fibers are melt-blown microfibers.
6. The electret article of claim 4, wherein the microfibers have an effective fiber diameter of about 1 to 20 micrometers.
7. The electret article of claim 2, wherein the  $\text{CF}_3:\text{CF}_2$  ratio is at least about 0.2.
8. The electret article of claim 2, wherein the  $\text{CF}_3:\text{CF}_2$  ratio is at least about 0.3.
9. The electret article of claim 8, wherein the  $\text{CF}_3:\text{CF}_2$  ratio is less than about 0.7.
10. The electret article of claim 9, wherein the  $\text{CF}_3:\text{CF}_2$  ratio is less than about 0.6.
11. The electret article of claim 2, wherein the volume resistivity is about  $10^{16}$  ohm·cm or greater.

12. The electret article of claim 3, having a basis weight of about 2 to 500 g per m<sup>2</sup>.
13. The electret article of claim 12, having a basis weight of about 20 to 150 g per m<sup>2</sup>.
14. The electret article of claim 3, wherein the fibrous web has a thickness of about 0.25 to 20 mm.
15. The electret article of claim 3, wherein the nonwoven web of fibers has a solidity of about 1 to 25.
16. The electret article of claim 15, wherein the nonwoven web of fibers has a solidity of about 3 to 10.
17. A filtering face mask that comprises a filter element that includes the electret article of claim 3.
18. A respirator that has a filter cartridge that contains the electret article of claim 3 as a filter material.
19. A filter element that comprises the electret article of claim 1, being in the form of an array of multiple flow channels.
20. The electret article of claim 2, wherein the surface of the polymeric material has about 45 to 60 atomic percent fluorine.
21. The electret article of claim 2, having a fluorosaturation ratio of greater than about 250.
22. The electret article of claim 21, having a fluorosaturation ratio greater than about 300.
23. The electret article of claim 3, having a Q9 value of at least about 1.40 or greater per mmH<sub>2</sub>O.



24. The electret article of claim 24, having a Q<sub>9</sub> value of at least about 1.5 per mmH<sub>2</sub>O.
25. The electret article of claim 24, having a Q<sub>9</sub> value of at least about 2.0 per mmH<sub>2</sub>O.
26. The electret article of claim 1, wherein the electric charge is imparted thereto by at least hydrocharging.
27. The electret article of claim 1, wherein the polymeric material is nonconductive, wherein the electret exhibits persistent electric charge, and wherein the fibers are spunbond fibers.
28. The electret article of claim 3, further comprising multiple layers of nonwoven webs of fibers.
29. The filtering facemask of claim 17, wherein the mask includes a mask body that is adapted to fit over the nose and mouth of a wearer, and wherein the electret filter media is disposed in the mask body.

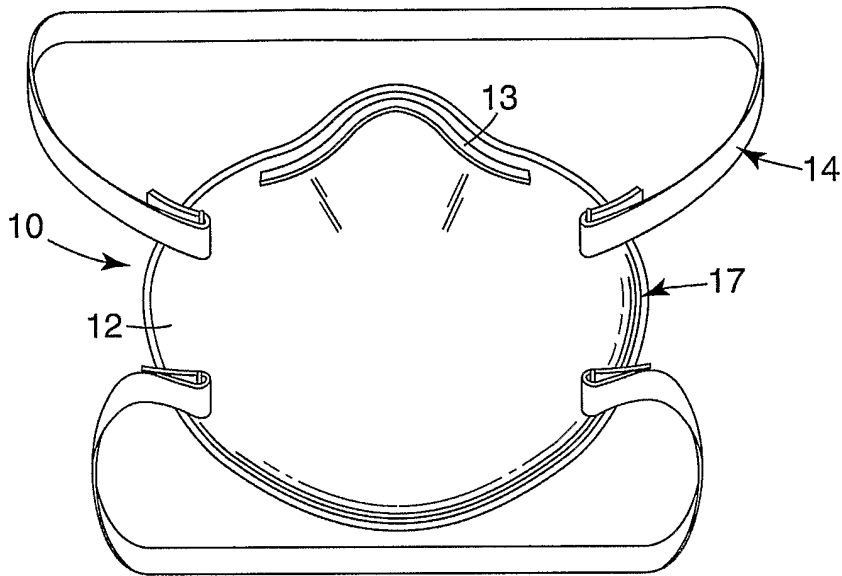

**Fig. 1**

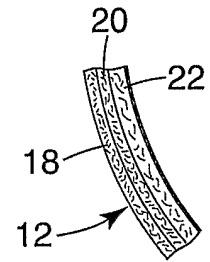

**Fig. 2**

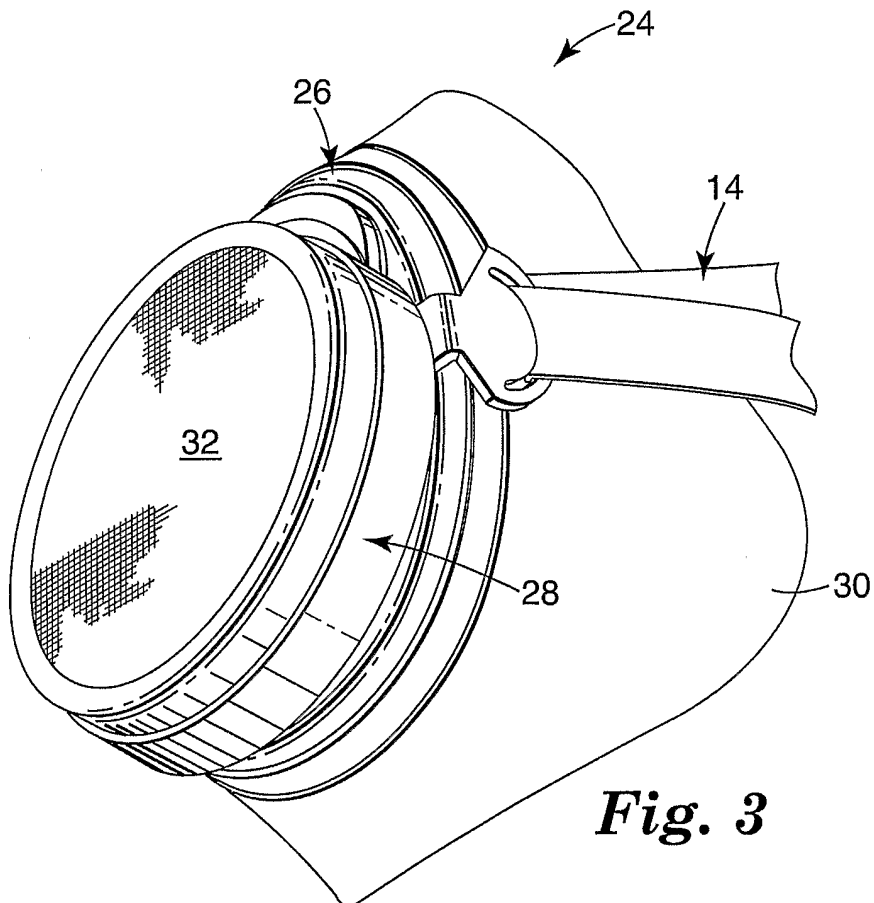

**Fig. 3**

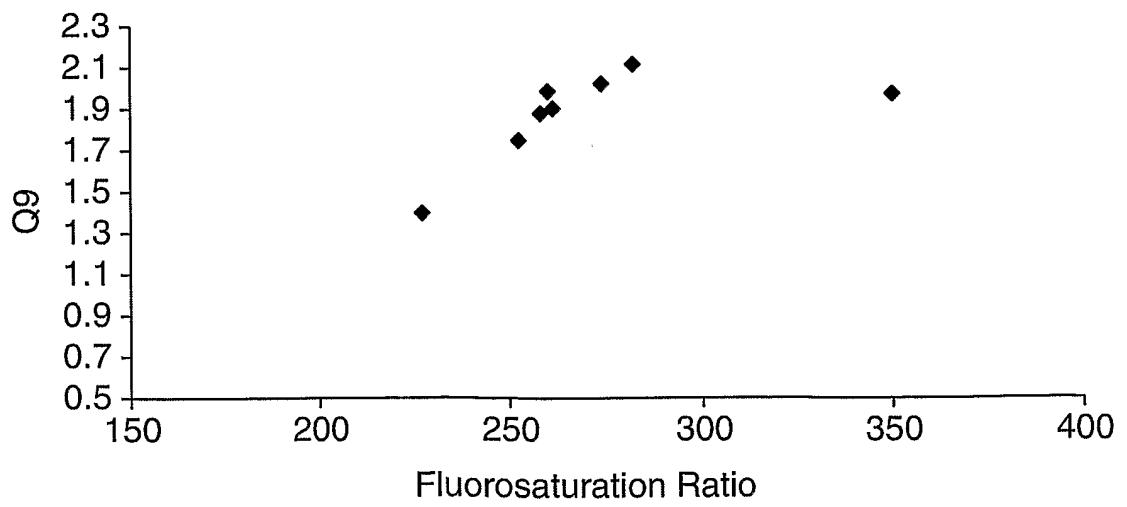
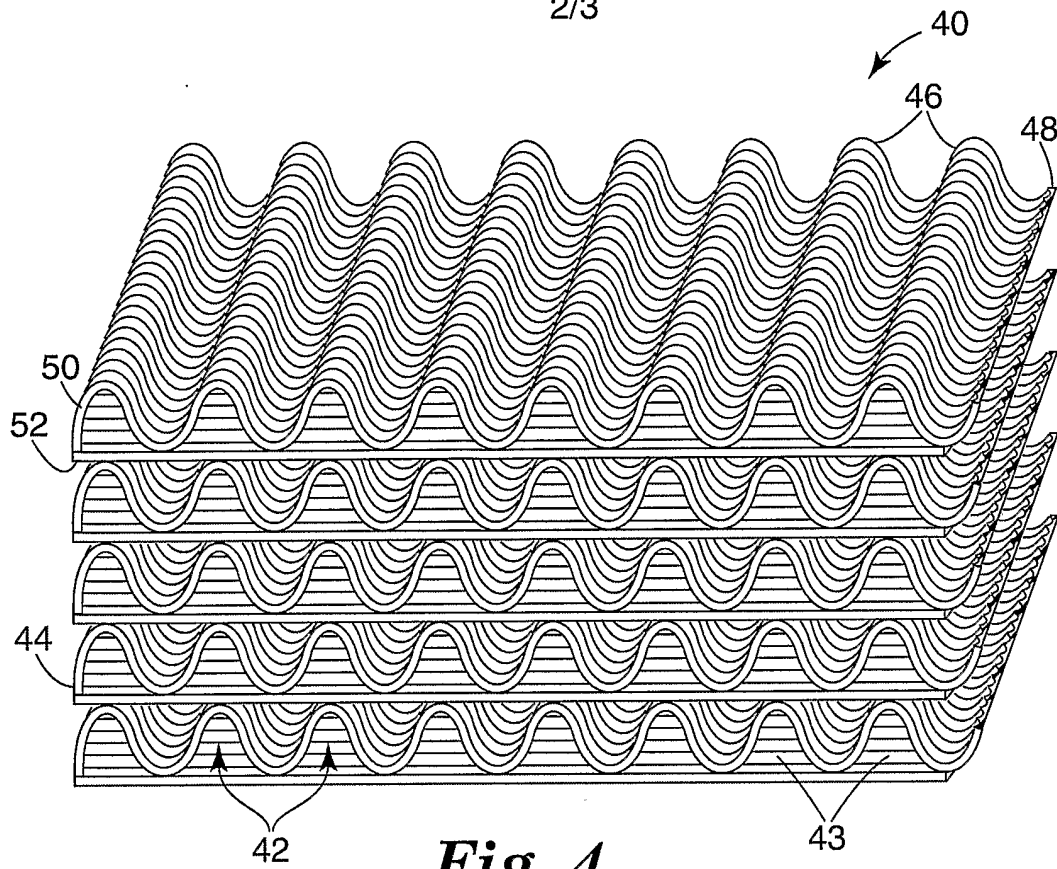

*Fig. 6*

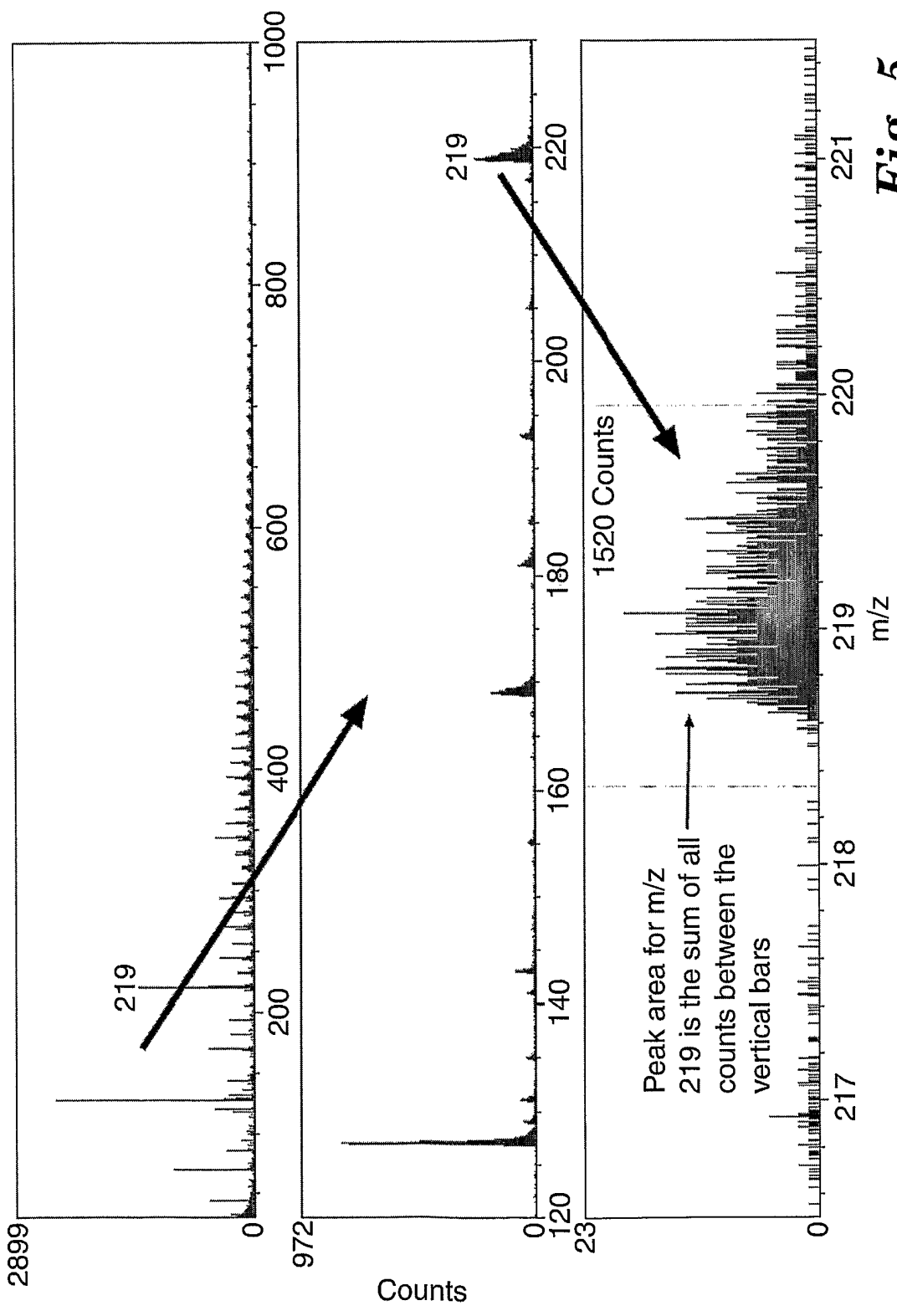

**Fig. 5**