



(86) Date de dépôt PCT/PCT Filing Date: 2006/03/30  
 (87) Date publication PCT/PCT Publication Date: 2006/10/26  
 (85) Entrée phase nationale/National Entry: 2007/10/17  
 (86) N° demande PCT/PCT Application No.: US 2006/011623  
 (87) N° publication PCT/PCT Publication No.: 2006/113080  
 (30) Priorités/Priorities: 2005/04/18 (US60/672,402);  
 2006/03/24 (US11/389,002)

(51) Cl.Int./Int.Cl. *A61B 17/56* (2006.01),  
*A61B 17/58* (2006.01), *A61F 2/30* (2006.01)

(71) Demandeur/Applicant:  
 ST. FRANCIS MEDICAL TECHNOLOGIES, INC., US

(72) Inventeurs/Inventors:  
 ZUCHERMAN, JAMES F., US;  
 HSU, KEN Y., US;  
 KLYCE, HENRY A., US;  
 WINSLOW, CHARLES J., US;  
 YERBY, SCOTT A., US;  
 FLYNN, JOHN J., US;  
 MITCHELL, STEVEN T., US;  
 MARKWART, JOHN A., US

(74) Agent: FETHERSTONHAUGH & CO.

(54) Titre : **IMPLANT D'APOPHYSES EPINEUSES PRESENTANT DES AILES DEPLOYABLES ET PROCEDE  
 D'IMPLANTATION**

(54) Title: **INTERSPINOUS PROCESS IMPLANT HAVING DEPLOYABLE WINGS AND METHOD OF IMPLANTATION**

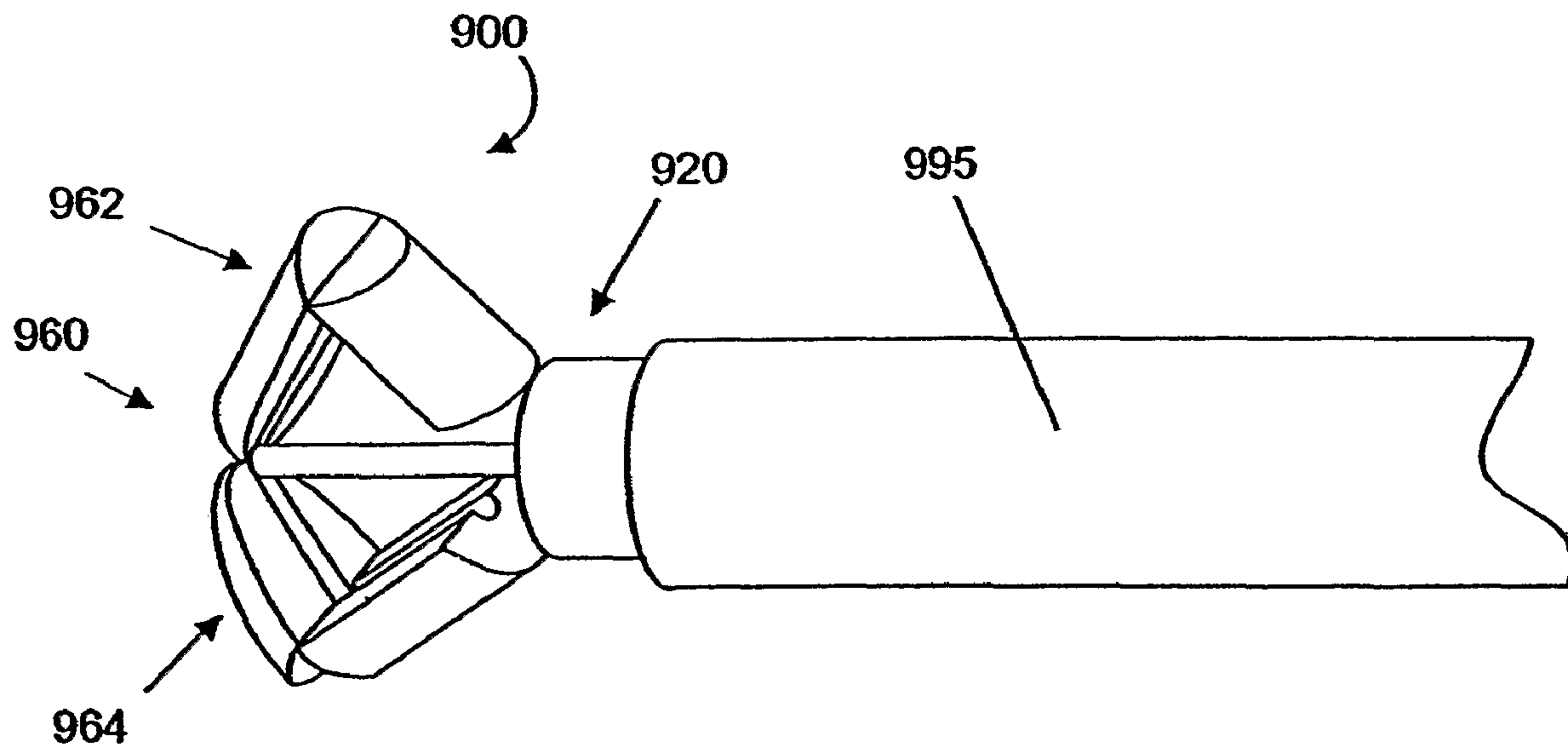

(57) **Abrégé/Abstract:**

An embodiment of a system in accordance with the present invention can include an implant having a spacer with a thickness and a wing, wherein a first configuration of the wing has a first height substantially similar to the thickness and wherein the wing is adapted to be selectably arranged in a second configuration such that the wing has a second height greater than the first height. A periphery of the implant has a shape generally conformal with a shape of an inner surface of a cannula and a cross-sectional diameter smaller than an inner diameter of the cannula. The cannula is inserted such that a proximal end of the cannula is arranged between the adjacent spinous processes. The implant is then urged into position between the adjacent spinous processes by way of the cannula, and subsequently arranged in a second configuration to fix the implant in position.

## (12) INTERNATIONAL APPLICATION PUBLISHED UNDER THE PATENT COOPERATION TREATY (PCT)

(19) World Intellectual Property Organization  
International Bureau(43) International Publication Date  
26 October 2006 (26.10.2006)

PCT

(10) International Publication Number  
**WO 2006/113080 A3**

## (51) International Patent Classification:

A61B 17/56 (2006.01) A61F 2/30 (2006.01)  
A61B 17/58 (2006.01)

## (21) International Application Number:

PCT/US2006/011623

(22) International Filing Date: 30 March 2006 (30.03.2006)

(25) Filing Language: English

(26) Publication Language: English

## (30) Priority Data:

60/672,402 18 April 2005 (18.04.2005) US  
11/389,002 24 March 2006 (24.03.2006) US

(71) Applicant (for all designated States except US): **ST. FRANCIS MEDICAL TECHNOLOGIES, INC.** [US/US]; 1201 Marina Village Parkway, Suite 200, Alameda, CA 94501 (US).

## (72) Inventors; and

(75) Inventors/Applicants (for US only): **ZUCHERMAN, James, F.** [US/US]; 3035 Pierce Street, San Francisco, California 94123 (US). **HSU, Ken, Y.** [US/US]; 52 Clarendon Avenue, San Francisco, California 94114 (US). **KLYCE, Henry, A.** [US/US]; 231 Sandringham Road, Piedmont, California 94611 (US). **WINSLOW,**

**Charles, J.** [US/US]; 25 Hilton Court, Walnut Creek, California 94595 (US). **YERBY, Scott, A.** [US/US]; 1333 Birch Street, Montara, California 94037 (US). **FLYNN, John, J.** [US/US]; 18 Baldwin Drive, West Milford, New Jersey 07480 (US). **MITCHELL, Steven, T.** [US/US]; 776 Duke Circle, Pleasant Hill, California 94523 (US). **MARKWART, John, A.** [US/US]; 4808 Heyer Avenue, Castro Valley, California 94552 (US).

(74) Agent: **TOWNSEND AND TOWNSEND AND CREW LLP**; Two Embarcadero Center., 8th Floor, San Francisco, CA 94111 (US).

(81) Designated States (unless otherwise indicated, for every kind of national protection available): AE, AG, AL, AM, AT, AU, AZ, BA, BB, BG, BR, BW, BY, BZ, CA, CH, CN, CO, CR, CU, CZ, DE, DK, DM, DZ, EC, EE, EG, ES, FI, GB, GD, GE, GH, GM, HR, HU, ID, IL, IN, IS, JP, KE, KG, KM, KN, KP, KR, KZ, LC, LK, LR, LS, LT, LU, LV, LY, MA, MD, MG, MK, MN, MW, MX, MZ, NA, NG, NI, NO, NZ, OM, PG, PH, PL, PT, RO, RU, SC, SD, SE, SG, SK, SL, SM, SY, TJ, TM, TN, TR, TT, TZ, UA, UG, US, UZ, VC, VN, YU, ZA, ZM, ZW.

(84) Designated States (unless otherwise indicated, for every kind of regional protection available): ARIPO (BW, GH, GM, KE, LS, MW, MZ, NA, SD, SL, SZ, TZ, UG, ZM, ZW), Eurasian (AM, AZ, BY, KG, KZ, MD, RU, TJ, TM),

[Continued on next page]

(54) Title: INTERSPINOUS PROCESS IMPLANT HAVING DEPLOYABLE WINGS AND METHOD OF IMPLANTATION

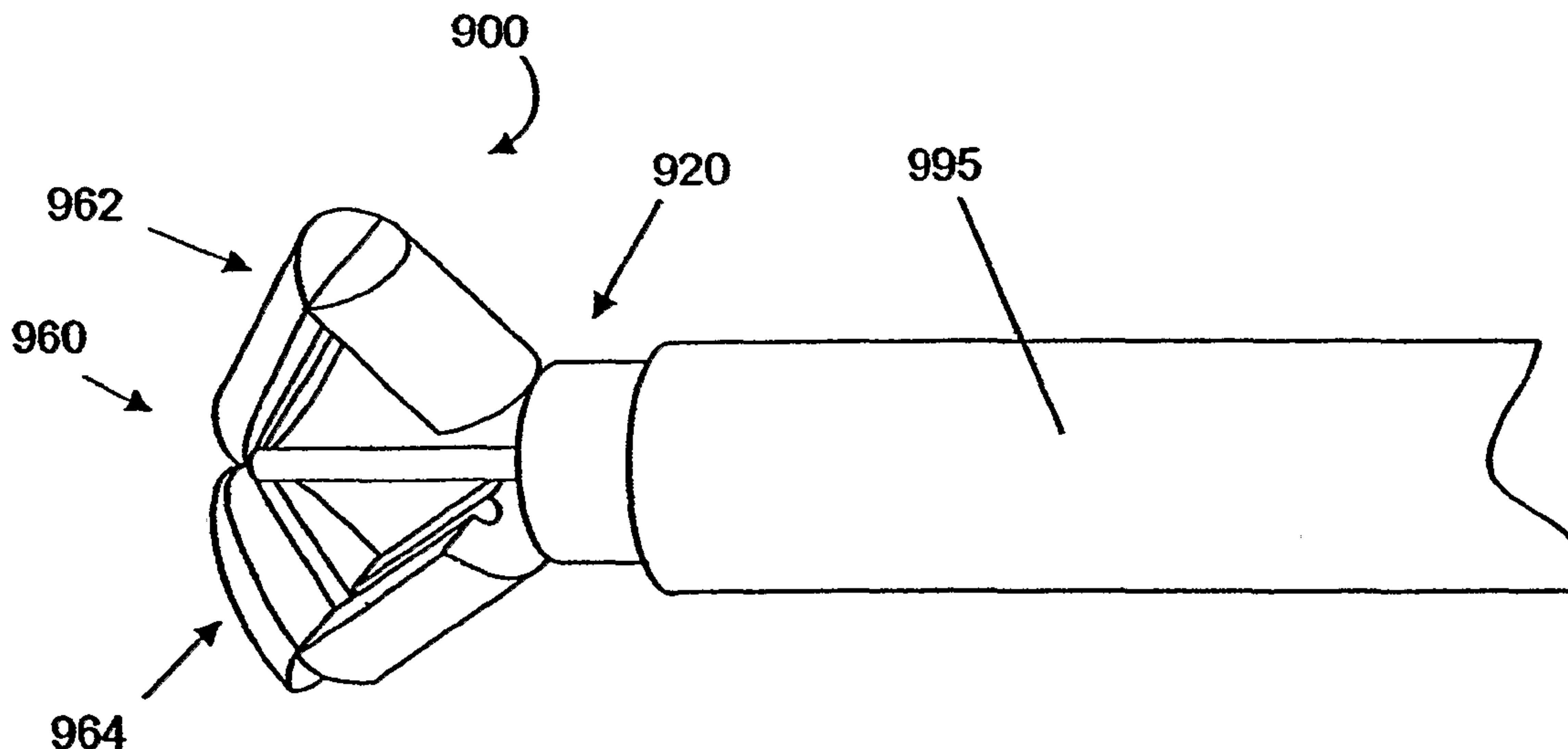

(57) Abstract: An embodiment of a system in accordance with the present invention can include an implant having a spacer with a thickness and a wing, wherein a first configuration of the wing has a first height substantially similar to the thickness and wherein the wing is adapted to be selectably arranged in a second configuration such that the wing has a second height greater than the first height. A periphery of the implant has a shape generally conformal with a shape of an inner surface of a cannula and a cross-sectional diameter smaller than an inner diameter of the cannula. The cannula is inserted such that a proximal end of the cannula is arranged between the adjacent spinous processes. The implant is then urged into position between the adjacent spinous processes by way of the cannula, and subsequently arranged in a second configuration to fix the implant in position.

WO 2006/113080 A3

**WO 2006/113080 A3**



European (AT, BE, BG, CH, CY, CZ, DE, DK, EE, ES, FI, FR, GB, GR, HU, IE, IS, IT, LT, LU, LV, MC, NL, PL, PT, RO, SE, SI, SK, TR), OAPI (BF, BJ, CF, CG, CI, CM, GA, GN, GQ, GW, ML, MR, NE, SN, TD, TG).

**(88) Date of publication of the international search report:**  
25 October 2007

**Published:**

— *with international search report*

*For two-letter codes and other abbreviations, refer to the "Guidance Notes on Codes and Abbreviations" appearing at the beginning of each regular issue of the PCT Gazette.*



**INTERSPINOUS PROCESS IMPLANT HAVING DEPLOYABLE  
WINGS AND METHOD OF IMPLANTATION**

5

**CLAIM OF PRIORITY**

U.S. Provisional Application No. 60/672,402 entitled INTERSPINOUS PROCESS IMPLANT HAVING DEPLOYABLE WINGS AND METHOD OF IMPLANTATION, by James F. Zucherman *et al.*, filed April 18, 2005 (Attorney Docket No. KLYC-01096US0); and

10 U.S. Patent Application No. 11/389,002 entitled INTERSPINOUS PROCESS IMPLANT HAVING DEPLOYABLE WINGS AND METHOD OF IMPLANTATION, by James F. Zucherman *et al.*, filed March 24, 2006 (Attorney Docket No. KLYC-01096US1).

**TECHNICAL FIELD**

This invention relates to interspinous process implants.

15

**BACKGROUND OF THE INVENTION**

The spinal column is a bio-mechanical structure composed primarily of ligaments, muscles, vertebrae and intervertebral disks. The bio-mechanical functions of the spine include: (1) support of the body, which involves the transfer of the weight and the bending  
20 movements of the head, trunk and arms to the pelvis and legs, (2) complex physiological motion between these parts, and (3) protection of the spinal cord and the nerve roots.

As the present society ages, it is anticipated that there will be an increase in adverse spinal conditions which are characteristic of older people. By way of example only, with aging comes an increase in spinal stenosis (including, but not limited to, central canal and lateral  
25 stenosis), and facet arthropathy. Spinal stenosis results in a reduction foraminal area (*i.e.*, the available space for the passage of nerves and blood vessels) which compresses the cervical nerve roots and causes radicular pain. Humpreys, S.C. *et al.*, *Flexion and traction effect on C5-C6 foraminal space*, Arch. Phys. Med. Rehabil., vol. 79 at 1105 (Sept. 1998). Another symptom of spinal stenosis is myelopathy, which results in neck pain and muscle weakness.  
30 *Id.* Extension and ipsilateral rotation of the neck further reduces the foraminal area and

contributes to pain, nerve root compression and neural injury. *Id.*; Yoo, J.U. *et al.*, *Effect of cervical spine motion on the neuroforaminal dimensions of human cervical spine*, *Spine*, vol. 17 at 1131 (Nov. 10, 1992). In contrast, neck flexion increases the foraminal area. Humpreys, S.C. *et al.*, at 1105. Pain associated with stenosis can be relieved by medication and/or surgery. It is desirable to eliminate the need for major surgery for all individuals, and in particular, for the elderly.

Accordingly, a need exists to develop spine implants that alleviate pain caused by spinal stenosis and other such conditions caused by damage to, or degeneration of, the cervical spine. Such implants would distract, or increase the space between, the vertebrae to increase the foraminal area and reduce pressure on the nerves and blood vessels of the cervical spine.

A further need exists for development of a minimally invasive surgical implantation method for cervical spine implants that preserves the physiology of the spine.

Further, a need exists for an implant that accommodates the distinct anatomical structures of the spine, minimizes further trauma to the spine, and obviates the need for invasive methods of surgical implantation. Additionally, a need exists to address adverse spinal conditions that are exacerbated by spinal extension.

#### **BRIEF DESCRIPTION OF THE DRAWINGS**

Further details of embodiments of the present invention are explained with the help of the attached drawings in which:

**FIG. 1** is a perspective view of an embodiment of an implant in accordance with the present invention having a spacer, a distraction guide, and a wing with an elliptical cross-section.

**FIG. 2** is an end view of the implant of **FIG. 1**.

**FIG. 3** is a perspective view of another embodiment of an implant in accordance with the present invention having a wing with a teardrop-shaped cross-section.

**FIG. 4** is an end view of a second wing for use with the implant of **FIG. 3**.

**FIG. 5** is a perspective view of an embodiment of an implant in accordance with the present invention having a rotatable spacer and a wing with an elliptical cross-section.



**FIG. 6** is a perspective view of an embodiment of an implant in accordance with the present invention having a rotatable spacer with two wings that are teardrop-shaped in cross-section.

**FIG. 7** depicts the axis of rotation of the implant of **FIG. 6** as seen from an end view.

5 **FIG. 8** is a perspective view of an embodiment of an implant in accordance with the present invention having a wing that is truncated at a posterior end.

**FIG. 9A** is an end view of the implant of **FIG. 8**.

**FIG. 9B** is a truncated second wing for use with the implant of **FIG. 9A**.

10 **FIG. 10** is a plan view of an embodiment of an implant in accordance with the present invention wherein a screw is used to secure a second wing to the spacer.

**FIG. 11** is a perspective view of the second wing of **FIG. 10**.

**FIG. 12** is a perspective view of the implant of **FIG. 10**.

15 **FIG. 13A** is a front view of a second wing for use with some embodiments of implants of the present invention having a flexible hinge mechanism for securing the second wing to an implant.

**FIG. 13B** is a side-sectional view of the second wing of **FIG. 13A**.

**FIG. 14A** is a plan view of an embodiment of an implant for use with the second wing of **FIGs. 13A** and **13B**.

**FIG. 14B** is a front view of the second wing of **FIGs. 13A** and **13B**.

20 **FIG. 15A** is a top view of an embodiment of an implant in accordance with the present invention positioned between spinous processes of adjacent cervical vertebrae.

**FIG. 15B** is a top view of the implant of **FIG. 15A** showing wing orientation.

**FIG. 16** is a top view of two such implants of the invention of **FIGs. 15A** and **15B**, positioned in the cervical spine.

25 **FIG. 17** is a side view of two implants of the invention positioned in the cervical spine, with stops or keeps at the proximal ends of the spinous processes.

**FIG. 18A** is a perspective view of an alternative embodiment of an implant in accordance with the present invention having a first wing and a second wing that can be deployed after arranging the implant between adjacent spinous processes.

**FIG. 18B** is a perspective view of the implant of **FIG. 18B** in a deployed configuration.

**FIG. 19A** is a posterior view of the implant of **FIGS. 18A** and **18B** positioned between adjacent spinous processes in an undeployed configuration.

5 **FIG. 19B** is a posterior view of the implant of **FIGS. 18A** and **18B** positioned between adjacent spinous processes in a deployed configuration.

**FIG. 20A** is a perspective view of still another embodiment of an implant in accordance with the present invention having a first wing and a second wing that can be deployed after arranging the implant between adjacent spinous processes.

10 **FIG. 20B** is a perspective view of the implant of **FIG. 20A** in a deployed configuration.

**FIG. 21** is a posterior view of the implant of **FIGS. 20A** and **20B** positioned between adjacent spinous processes in a deployed configuration.

15 **FIG. 22A** is a perspective view of an alternative embodiment of an implant in accordance with the present invention having a first wing and a second wing that can be deployed after arranging the implant between adjacent spinous processes.

**FIG. 22B** is a perspective view of the implant of **FIG. 22A** in a partially deployed configuration.

20 **FIG. 22C** is a perspective view of the implant of **FIG. 22A** in a fully deployed configuration.

**FIG. 23A** is a perspective view of the implant of **FIG. 22A** including a cannula within which the implant is disposed for insertion into desired location between adjacent spinous processes.

25 **FIG. 23B** is a perspective view of the implant of **FIG. 23A** in a partially deployed configuration.

**FIG. 23C** is a perspective close-up view of the implant of **FIG. 23A** showing hinged structures connected by cords.

**FIG. 24** illustrates an embodiment of a method for implanting an interspinous implant as shown in **FIGS. 1-17** in accordance with the present invention.



**FIG. 25** illustrates an embodiment of a method for implanting an interspinous implant as shown in **FIGs. 18A-21** having deployable first and second wings in accordance with the present invention.

**FIG. 26** illustrates an alternative embodiment of a method for implanting an interspinous implant as shown in **FIGs. 22A-23B** having deployable first and second wings by way of a cannula inserted between adjacent spinous processes in accordance with the present invention.

### DETAILED DESCRIPTION

10

#### **INTERSPINOUS IMPLANTS**

**FIGs. 1** and **2** illustrate an implant **100** in accordance with an embodiment of the present invention. The implant **100** comprises a wing **130**, a spacer **120**, and a lead-in tissue expander (also referred to herein as a distraction guide) **110**. The distraction guide **110** in this particular embodiment is wedge-shaped, *i.e.*, the implant has an expanding cross-section from a distal end of the implant **102** to a region **104** where the guide **110** joins with the spacer **120** (referencing for the figures is based on the point of insertion of the implant between spinous processes). As such, the distraction guide functions to initiate distraction of the soft tissue and the spinous processes when the implant **100** is surgically inserted between the spinous processes. It is to be understood that the distraction guide **110** can be pointed and the like, in order to facilitate insertion of the implant **100** between the spinous processes of adjacent cervical vertebrae. It is advantageous that the insertion technique disturb as little of the bone and surrounding tissue or ligaments as possible in order to reduce trauma to the site and promote early healing, and prevent destabilization of the normal anatomy. In the embodiment of **FIGs. 1** and **2**, there is no requirement to remove any of the bone of the spinous processes and no requirement to sever or remove from the body ligaments and tissues immediately associated with the spinous processes. For example, it is unnecessary to sever the *ligamentum nuchae* (supraspinous ligament), which partially cushions the spinous processes of the upper cervical vertebrae.

30

As can be seen in **FIGs. 1-3**, the spacer **120** can be teardrop-shaped in cross-section



perpendicular to a longitudinal axis **125** of the implant **100**. In this way, the shape of the spacer **120** can roughly conform to a wedge-shaped space, or a portion of the space, between adjacent spinous processes within which the implant **100** is to be positioned. In other embodiments, the spacer **120**, can have alternative shapes such as circular, wedge, elliptical, ovoid, football-shaped, and rectangular-shaped with rounded corners and other shapes, and be within the spirit and scope of the invention. The shape of the spacer **120** can be selected for a particular patient so that the physician can position the implant **100** as close as possible to the anterior portion of the surface of the spinous process. The shape selected for the spacer **120** can affect the contact surface area of the implant **100** and the spinous processes that are to be subject to distraction. Increasing the contact surface area between the implant **100** and the spinous processes can distribute the force and load between the spinous frame and the implant **100**.

As can be seen in **FIGs. 1** and **2**, the wing **130** in an embodiment can be elliptically shaped in cross-section perpendicular to the longitudinal axis **125**. The dimensions of the wing **130** can be larger than that of the spacer **120**, particularly along the axis of the spine, and can limit or block lateral displacement of the implant **100** in the direction of insertion along the longitudinal axis **125**. As illustrated in the embodiment of **FIG. 3**, the wing **130** can alternatively have other cross-sectional shapes, such as teardrop, wedge, circular, ovoid, football-shaped, and rectangular-shaped with rounded corners and other shapes, and be within the spirit and scope of the invention. The wing **130** has an anterior portion **138** and a posterior portion **136**.

In other embodiments, the implant **100** can include two wings, with a second wing **160** (shown in **FIG. 4**) separate from the distraction guide **110**, spacer **120** and first wing **130**. The second wing **160** can be connected to the distal end of the spacer **120**. The second wing **160**, similar to the first wing **130**, can limit or block lateral displacement of the implant **100**, however displacement is limited or blocked in the direction along the longitudinal axis **125** opposite insertion. When both the first wing **130** and the second wing **160** are connected with the implant **100** and the implant **100** is positioned between adjacent spinous processes, a portion of the spinous processes can be sandwiched between the first wing **130** and the second

wing **160**, limiting any displacement along the longitudinal axis **125**.

As can be seen in **FIG. 4**, the second wing **160** can be teardrop-shaped in cross-section. The wider end **166** of the second wing **160** is the posterior end and the narrower end **168** of the second wing **160** is the anterior end. Unlike the first wing **130**, however, an opening **164** is defined within the second wing **160**, the opening **164** being at least partially circumscribed by a lip **162** that allows the second wing **160** to pass over the distraction guide **110** to meet and connect with the spacer **120**. The second wing **160** can be secured to the spacer **120** once the second wing **160** is properly positioned. The second wing **160** can be connected with the implant after the implant **100** is positioned between the spinous processes.

It is to be understood that the implant can be made in two pieces. The first piece can include the first wing **130**, the spacer **120**, and the distraction guide **110**. The second piece can include the second wing **160**. Each piece can be manufactured using technique known in the art (e.g., machining, molding, extrusion). Each piece, as will be more fully discussed below, can be made of a material that is bio-compatible with the body of the patient. An implant can be formed with multiple pieces and with the pieces appropriately joined together, or alternatively, an implant can be formed as one piece or joined together as one piece.

Further embodiments of implants in accordance with the present invention are depicted in **FIGs. 5-7**. In such embodiments, the spacer **220** can be rotatable about the longitudinal axis **225** relative to the first wing **130**, or relative to the first wing **130** and a second wing **160** where two wings are used. The spacer **220** can be rotatable or fixed relative to the distraction guide **110**. Where the spacer **220** is rotatable relative to the distraction guide **110**, the spacer **220** can include a bore **222** running the length of the longitudinal axis **225**, and a shaft **224** inserted through the bore **222** and connecting the distraction guide **110** with the first wing **130**.

It can be advantageous to position any of the implants taught herein as close as possible to the vertebral bodies. The rotatable spacer **220** can rotate to conform to or settle between adjacent spinous processes as the implant **200** is inserted and positioned during implantation, so that on average the contact surface area between the spacer **220** and the spinous processes can be increased over the contact surface area between a fixed spacer **120** and the spinous processes. Thus, the rotatable spacer **220** can improve the positioning of the spacer **220** independent of



the wings **130,160** relative to the spinous processes. The embodiment of **FIG. 6** includes a teardrop-shaped first wing **130**, and a teardrop-shaped second wing **160**, similar to the second wing **160** depicted in the embodiment of **FIG. 3**. As discussed below, the shape of the wings **130,160** in **FIGs. 3** and **6** is such that the implants **100,200** accommodate the twisting of the cervical spine along its axis, for example, as the head of a patient turns from side-to-side.

**FIG. 8** is a perspective view and **FIG. 9A** is an end view of still another embodiment of an implant in accordance with the present invention, wherein the posterior portion **336** of the teardrop-shaped first wing **330** is truncated, making the first wing **330** more ovoid in shape. In this configuration, the anterior portion **138** of the first wing **330** can be longer than the truncated posterior end **336** of the first wing **330**. As in previous embodiments, the spacer **120** can alternatively be a rotatable spacer rather than a fixed spacer. **FIG. 9B** illustrates a second wing **360** for use with such implants **300**, the second wing **360** having a truncated posterior end **366**. Truncation of the posterior ends **336,366** of the first and second wings **330,360** can reduce the possibility of interference of implants **300** having such first and second wings **330,360** positioned between spinous processes of adjacent pairs of cervical vertebrae, e.g., implants between cervical vertebrae five and six, and between cervical vertebrae six and seven. During rotation of the neck, the spinous process move past each other in a scissor-like motion. Each cervical vertebra can rotate relative to the next adjacent cervical vertebra in the general range of about  $6^{\circ}$ - $12^{\circ}$ . In addition, about 50 percent of the rotational movement of the neck is accomplished by the top two neck vertebrae. Thus, such embodiments can accommodate neck rotation without adjacent embodiments interfering with each other.

With respect to the prior embodiments which have first and second wings **130,160**, the second wing **160**, can be designed to be interference-fit onto the spacer **120** (where the spacer is fixed) or a portion of the distraction guide **110** adjacent to the spacer **120** (where the spacer is rotatable). Where the second wing **160** is interference-fit, there is no additional attachment device to fasten the second wing **160** relative to the remainder of the implant. Alternatively, various fasteners can be used to secure the second wing relative to the remainder of the implant. For example, **FIGs. 10-12** illustrate an embodiment of an implant **400** including a teardrop-shaped second wing **460** having a bore **463** through a tongue **461** at the posterior end



of the second wing 460. The bore 463 is brought into alignment with a corresponding bore 440 on the spacer 120 when the second wing 460 is brought into position by surgical insertion relative to the rest of the implant 400. A threaded screw 442 can be inserted through the aligned bores 463,440 in a posterior-anterior direction to secure the second wing 460 to the spacer 120. The direction of insertion from a posterior to an anterior direction has the screw 442 engaging the bores 463,440 and the rest of the implant 400 along a direction that is generally perpendicular to the longitudinal axis 125. This orientation is most convenient when the surgeon is required to use a screw 442 to secure the second wing 460 to the rest of the implant 400. Other securing mechanisms using a member inserted into corresponding bores 463,440 on the spacer 120 and second wing 460 are within the spirit of the invention. It should be understood that a rotatable spacer 220 also can be accommodated by this embodiment. With a rotatable spacer 220, the second wing 460 would be attached to a portion of the distraction guide 110 that is located adjacent to the rotatable spacer 220.

FIGs. 13A-14B depict a further embodiment 500 wherein the second wing 560 is secured to the spacer 120 by a mechanism including a flexible hinge 565, with a protrusion 561 on the end of the hinge 565 adjacent to the lip 562 of the opening 564 defined by portions of the second wing 560. The securing mechanism also encompasses an indentation 540 on the spacer 120, wherein the indentation 540 accommodates the protrusion 561 on the end of the flexible hinge 565. During surgery, after insertion of the distraction guide 110, spacer 120, and first wing 130, the second wing 560 is received over the distraction guide 110 and the spacer 120. As the second wing 560 is received by the spacer 120, the flexible hinge 565 and its protrusion 561 deflect until the protrusion 561 meets and joins with the indentation 540 in the spacer 120, securing the second wing 560 to the spacer 120. Again in embodiments where the spacer can rotate, the indentation 540 is located on an end of the distraction guide 110 that is adjacent to the rotatable spacer 220. With respect to the flexible hinge 565, this hinge is in a preferred embodiment formed with the second wing 560 and designed in such a way that it can flex as the hinge 565 is urged over the distraction guide 110 and the spacer 120 and then allow the protrusion 561 to be deposited into the indentation 540. Alternatively, it can be appreciated that the indentation 540 can exist in the second wing 560 and the flexible hinge



565 and the protrusion 561 can exist on the spacer 120 in order to mate the second wing 560 to the spacer 120. Still alternatively, the flexible hinge 565 can be replaced with a flexible protrusion that can be flexed into engagement with the indentation 540 in the embodiment with the indentation 540 in the spacer 120 or in the embodiment with the indentation 540 in the second wing 560. One of ordinary skill in the art will appreciate the myriad different ways with which the second wing can be mated with the implant.

FIGs. 15A-16 illustrate an embodiment of an implant 600 wherein anterior ends of a first wing 630 and second wing 660 flare out at an angle away from the spacer 120 and away from each other. The cervical spinous processes are themselves wedge-shaped when seen from a top view. The first wing 630 and second wing 660 flare out so that the implant 600 can roughly conform with the wedge shape of the spinous processes, allowing the implant 600 to be positioned as close as possible to the vertebral bodies of the spine where the load of the spine is carried. The first and second wings 630,660 are positioned relative to the spacer, whether the spacer is fixed 120 or rotatable 220, so that the wings flare out as the wings approach the vertebral body of the spine. FIG. 15B is a top view of the implant 600 of FIG. 15A removed from proximity with the spinous processes. The first wing 630 is aligned at an angle with respect to an axis along the spinous processes perpendicular to the longitudinal axis (also referred to herein as the plane of symmetry). In one embodiment, the angle is about 30°, however, the angle  $\theta$  can range from about 15° to about 45°. In other embodiments, other angles outside of this range are contemplated and in accordance with the invention. Likewise, the second wing 660 can be aligned along a similar, but oppositely varying range of angles relative to the plane of symmetry.

As described above in reference to FIG. 4, the second wing 660 defines an opening which is outlined by a lip. As is evident, the lip can be provided at an angle relative to the rest of the second wing 660 so that when the lip is urged into contact with the spacer 120, the second wing 660 has the desired angle relative to the spacer 120. As discussed above, there are various ways that the second wing 660 is secured to the spacer 120. FIG. 15A depicts a top view of one such implant 600 placed between the spinous processes of adjacent cervical vertebrae. FIG. 16 is a top view illustrating two layers of distracting implants 600 with flared

wings 630,660.

Systems and methods in accordance with the present invention can include devices that can be used in cooperation with implants of the present invention. **FIG. 17** illustrates “stops” (also referred to herein as “keeps”) 656, which are rings of flexible biocompatible material, which can be positioned around the spinous processes of adjacent cervical vertebrae and located posteriorly to the implant 600. The keeps 656 can prevent posterior displacement of implants. In one embodiment, the keeps can include a ring having a slit 658. The keeps 656 can be somewhat sprung apart, so that the keep 656 can be fit over the end of the spinous process and then allowed to spring back together in order to hold a position on the spinous process. The keep 656 can act as a block to the spacer 120 in order to prevent the implant 600 from movement in a posterior direction.

#### **IMPLANTS HAVING DEPLOYABLE WINGS**

In other embodiments, implants in accordance with the present invention can comprise a “matchbox”-like structure having a first configuration (as shown in **FIG. 18A**) and a second, deployed configuration (as shown in **FIG. 18B**). Arranged in the first configuration, such implants 700 can have a substantially flat profile having an approximately uniform thickness. The uniform thickness approximates the thickness of a spacer 720 of the implant 700. The implant 700 can comprise a distraction guide 710 at a proximal end of the implant, the distraction guide 710 having a slightly rounded or tapered shape to pierce and/or distract a space between adjacent spinous processes. The implant 700 can further comprise a plurality of hinged structures 750-757, the hinged structures 750-757 being collapsed so as to facilitate the substantially flat profile. The hinged structures 750-757 are pivotally connected with the spacer 720 and extend from both sides of the spacer 720. As shown in **FIG. 18A**, a support structure 722 extends from the spacer 720 toward the distal end of the implant 700. A rod 715 (or alternatively some other mechanism such as a tab) can be connected with the proximal end of the implant 700 and can extend through the hinged structures 750-753, through the spacer 720, and through the support structure 722 so that the rod 715 is accessible.

Referring to **FIG. 18B**, once the implant 700 is positioned as desired between adjacent



spinous processes, the rod 715 can be drawn in a direction opposite the direction of insertion along the longitudinal axis 725 so that the hinged structures 750-757 fold outward to form a first wing 730 and a second wing 760 between which is arranged the spacer 720 and a portion of the spinous processes. As the hinged structures 750-757 fold outward, the height of the first and second wings 730,760 increases from approximately the same as the thickness of the spacer 720 to a height such that the first and second wing 730,760 can limit or block movement of the implant 700 along the longitudinal axis 725 when positioned between adjacent spinous processes. As can be seen, the second wing 760 includes four hinged structures 750-753: an upper first structure 750 connected by a hinge to an upper second structure 752, and a lower first structure 751 connected by a hinge to a lower second structure 753. The hinged structures 750-753 pivot outward to form an upper end 762 of the second wing and a lower end 764 of the second wing. Likewise, the first wing 730 includes four hinged structures 754-757: an upper first structure 754 connected by a hinge to an upper second structure 756, and a lower first structure 755 connected by a hinge to a lower second structure 757. However, unlike the second wing 760, the first wing 730 is (effectively) bisected by the support structure 722 so that the first wing 730 comprises four winglets 731-734. The hinged structures 754-757 pivot outward to form upper winglets 731,732 of the first wing and lower winglets 733,734 of the first wing.

As mentioned above, the support structure 722 extends from the spacer 720 toward the distal end of the implant 700. The spacer 720 and the support structure 722 include a bore or other cavity through which the rod 715 can travel. Applying resistive force to the support structure 722 can fix the spacer 720 in place between spinous processes when drawing the rod 715 through the bore. As the rod 715 is drawn through the bore, the hinged structures 752,753 with which the proximal end of the rod 715 is connected are drawn with the rod 715. As the rod 715 is drawn through the spacer 720, the hinged structures 752,753 are drawn toward the spacer 720. The hinged structures 750-753 pivot outward to accommodate the relative movement between the rod 715 and the spacer 720. Accordingly, the second wing 760 has been satisfactorily deployed.

The hinged structures 756,757 of the first wing 730 can cause deployment of the first

wing 730 by applying resistive force to the hinged structures 756,757 while drawing the spacer 720 (via the support structure 722), or by urging the hinged structures 756,757 toward the spacer 720. The resistive force or urging can be applied by a second stop 784 that can fit around the support structure 722 and can be interference fit or otherwise selectively fixed with the support structure 722. As the second stop 784 is pushed along the longitudinal axis 725, along the support structure 722, the hinged structures 754-757 pivot outward to accommodate the relative movement between the second stop 784 and the spacer 720. Accordingly, the first wing 730 has been satisfactorily deployed.

FIGs. 19A and 19B are posterior views of the implant 700 positioned between adjacent spinous processes 2,4 demonstrating an embodiment of a method for deploying the implant 700 between the spinous processes 2,4. The implant 700 can be positioned so that a distraction guide 710 of the implant 700 is arranged at a space between the spinous processes 2,4. The implant 700 can then be urged between the spinous processes 2,4 so that the spacer 720 is positioned as desired. The substantially flat profile of the implant 700 can ease positioning of the spacer 720 by reducing potential obstructing surfaces that can resist movement of the implant 700 during implantation. The second wing 760 and the first wing 730 can then be deployed to limit movement of the implant 700. To deploy the second wing 760 the rod 715 is drawn in a direction opposite the direction of insertion along the longitudinal axis 725. The upper end 762 and lower end 764 of the second wing extend outward as described above. Once the second wing 760 is deployed, the rod 715 can be fixed in position relative to the spacer 720. This can be accomplished using myriad different mechanisms. For example, as shown a first stop 782 can be interference fit to the rod 715 and positioned against the support structure 722 along the rod 715. The first stop 782 can grip the rod 715, as with a friction fit between the first stop 782 and the rod 715, so that the rod 715 is prevented from moving through the bore of the support structure 722 by interference between the first stop 782 and the support structure 722. In other embodiments, some other mechanism can be used, such as a pin (e.g., a cotter pin), a latch system, etc. One of ordinary skill in the art will appreciate the myriad different mechanisms for fixing a rod 715 in position relative to the spacer 720. The upper second structure 756 and the lower second structure 757 can be



urged toward the spacer **720** in the direction of insertion along the longitudinal axis **725** using a second stop **784** as described above, causing the upper winglets **731,732** and lower winglets **733,734** to extend outward to form the first wing **730**. Once the first wing **730** is deployed, the hinged structures **754-757** can be fixed in position using the second stop **784** or some other  
5 mechanism. The second stop **784** can grip the support structure **722**, as with a friction fit or pin, and resist movement of the hinged structures **754-757**, thereby preventing collapse. As above, one of ordinary skill in the art will appreciate the myriad different mechanisms for fixing the first wing **730** in a deployed position. With the first wing **730** and the second wing **760** deployed, movement of the implant **700** along the longitudinal axis **725** can be limited or  
10 blocked, thereby resisting undesirable displacement of the implant **700**.

It should be noted that with implants as described above in reference to **FIGs. 18A-21** the rod **715** can optionally be trimmed or otherwise partially detached to decrease a space required to accommodate the implant **700,800** within the patient's spine. For example, the structure of the rod **715** can be beveled or otherwise weakened near a distal end of the rod **715**  
15 to allow the rod **715** to be snapped off when the first and second wings **730,760,830,860** are deployed and the rod **715** is fixed in place. In other embodiments, a tool (not shown) can be used to cut the rod **715** after the first and second wings **730,760,830,860** are deployed and the rod **715** is fixed in place. Still further, the rod **715** need not comprise a rigid structure, but rather alternatively can include a tether, string, or similarly flexible structure that can be placed  
20 in tension to retain the second wing **760,860** and/or first wing **730,830** in a deployed position.

Referring to **FIGs. 20A** and **20B**, a still further embodiment of an implant **800** in accordance with the present invention is shown. In such an embodiment, a flexible strap **890** can be connected between pairs of hinged structures (i.e., **850** and **852**, **851** and **853**, **854** and **856**, **855** and **857**). The flexible strap **890** can limit the relative movement of the hinged  
25 structures **850-857** so that first wing **830** and second wing **860** have increased rigidity when fully deployed. The implant **800** need not include the support structure **722** of the previous embodiment. A resistive force can be applied to the hinged structures **856,857** so that as the rod **715** is drawn in a direction opposite the direction of insertion along the longitudinal axis **825** the resistive force causes the hinged structures **854-857** to extend outward to form the first

wing **830**. As the hinged structures **854-857** extend outward the flexible strap **890** connected opposite the hinge unfolds. Once the hinged structures **854-857** reach a maximum extension, the flexible strap **890** becomes taut and resists further extension, locking the first wing **830** in place. The flexible straps **890** can provide the first wing **830** with sufficient rigidity to resist movement of the spacer **720**, so that as the rod **715** is further drawn the rod **715** moves through the spacer **720** and the hinged structures **852,853** connected with the rod **715** are drawn toward the spacer **720**. As the hinged structures **852,853** connected with the rod **715** are drawn toward the spacer **720**, all of the hinged structures **850-853** extend outward to deploy the second wing **860**. The flexible strap **890**, connected opposite the hinge, unfolds. Once the hinged structures **854-857** reach a maximum extension the flexible strap **890** becomes taut and resists further extension, locking the first wing **830** in place. A stop **882** (or alternatively some other mechanism such as a pin) can be fixed to the rod **715** to create interference between the stop **882** and the hinged structures **832,834** of the first wing **830** that resists movement of the rod **715**.

The flexible straps **890** can be made from a biocompatible material. In an embodiment, the flexible straps **890** can be made from a braided polyester suture material. Braided polyester suture materials include, for example, Ethibond, Ethiflex, Mersilene, and Dacron, and are non-absorbable, having high tensile strength, low tissue reactivity and improved handling. In other embodiments, the flexible straps **890** can be made from stainless steel (i.e., surgical steel), which can be woven into a strap, for example. In still other embodiments, flexible straps **890** can be made from some other material (or combination of materials) having similar properties.

**FIG. 21** is a posterior view of the implant **800** positioned between adjacent spinous processes **2,4** demonstrating an embodiment of a method for deploying the implant **800** between the spinous processes **2,4**. The first wing **830** can be deployed to limit movement of the implant **800** relative to the spinous processes **2,4**. To deploy the first wing **830** the rod **715** can be held fixed in position or urged in a direction opposite the direction of insertion along the longitudinal axis **825** while a force is applied to the hinged structures **854-857** (**FIG. 20A**) of the first wing **830** to cause the upper end **832** of the first wing and the lower end **834** of the



first wing to extend away from the rod **715**, thereby deploying the first wing **830**. The rod **715** can be further urged in the direction opposite the direction of insertion so that the proximal end of the rod **715** pivotably connected with the hinged structures **852,853** that comprise the distraction guide **710**, is drawn toward the spacer **720**, causing the upper end **862** of the spacer, and the lower end **864** of the spacer to extend away from the rod **715**. Once the second wing **860** and the first wing **830** are deployed, the rod **715** can be fixed in position relative to the spacer **720**. As above, this can be accomplished using myriad different mechanisms. For example, as shown a first stop **882** can be interference fit to the rod **715** and positioned against the first wing **830** along the rod **715**. The first stop **882** can grip the rod **715** so that the rod **715** is prevented from moving by a friction fit between the first stop **882** and the rod **715**. In other embodiments, some other mechanism can be used, such as a pin (e.g., a cotter pin), a latch system, etc. One of ordinary skill in the art will appreciate the myriad different mechanisms for fixing a rod **715** in position relative to the spacer **720**. With the first wing **830** and the second wing **860** deployed, movement of the implant **800** along the longitudinal axis **825** can be limited or blocked, thereby resisting undesirable displacement of the implant **800**.

Referring to **FIGs. 22A** and **22B**, in still other embodiments, implants in accordance with the present invention can comprise a “matchbox”-like structure having a rounded, collapsed first configuration and a second, deployed configuration. Arranged in the first configuration, such implants **900** can have a shape allowing the implant **900** to be more naturally inserted through a cannula. As shown, such a shape includes a substantially circular cross-section, though in other embodiments the implant can have an ovoid or elliptical cross-section, thereby allowing a spacer shape to be employed that generally accommodates a space between adjacent spinous processes. However, it will be appreciated that an implant **900** having a circular cross-section can most efficiently use the space of a cannula, where the cannula includes a circular cross-section; therefore, it may be preferable to employ an implant **900** having a circular cross-section where a physician desired to minify the diameter of the cannula inserted into the surgical site.

The cross-section of the implant **900** in a first configuration is generally consistent along the implant's length., having a diameter generally the thickness of a spacer **920** of the

implant **900**. The implant **900** can comprise a distraction guide **910** at a proximal end of the implant **900**, the distraction guide **910** having a rounded (as shown) or tapered shape to pierce and/or distract a space between adjacent spinous processes. However, where a cannula is employed to deliver an implant to a surgical site, the implant **900** can optionally include a distraction guide **910** at the proximal end. The surgical site, and associated tissues and structures can be distracted and repositioned by the cannula, allowing substantially unobstructed access to the surgical site by the implant **900**. In such circumstance a distraction guide **910** may not be necessary.

The implant **900** can further comprise a plurality of hinged structures **950-957**, the hinged structures **950-957** being collapsed so as to facilitate the substantially collapsed profile. The hinged structures **950-957** are pivotally connected with the spacer **920** and extend from both sides of the spacer **920**. A rod **915** (or alternatively some other mechanism such as a tab) can be connected with the proximal end of the implant **900** and can extend through the hinged structures **950-953**, and through the spacer **920** so that the rod **915** is accessible to a physician.

Referring to **FIGs. 22B** and **22C**, once the implant **900** is positioned as desired between adjacent spinous processes, the rod **915** can be drawn in a direction opposite the direction of insertion along the longitudinal axis **925** so that the hinged structures **950-957** fold outward to form a first wing **930** and a second wing **960** between which is arranged the spacer **920** and a portion of the spinous processes. As the hinged structures **950-957** fold outward, the height of the first and second wings **930,960** increases from approximately the same as the thickness of the spacer **920** to a height such that the first and second wing **930,960** can limit or block movement of the implant **900** along the longitudinal axis **925** when positioned between adjacent spinous processes. As can be seen, the second wing **960** includes four hinged structures **950-953**: an upper first structure **950** connected by a hinge to an upper second structure **952**, and a lower first structure **951** connected by a hinge to a lower second structure **953**. The hinged structures **950-953** pivot outward to form an upper end **962** of the second wing and a lower end **964** of the second wing. Likewise, the first wing **930** includes four hinged structures **954-957**: an upper first structure **954** connected by a hinge to an upper second structure **956**, and a lower first structure **955** connected by a hinge to a lower second



structure **957**.

Embodiments as described above in reference to **FIGs. 18A** and **18B** included a support structure **722** extending from the spacer **720**. Likewise, a support structure can optionally extend from the spacer **920** of the cannula delivered implant **900**. However, such a structure need not be necessary where the first wing **930** is prevented from deploying during deployment of the second wing **960** by the cannula **995** itself (see **FIG. 23B**). Referring to **FIGs. 23A** and **23B**, once the cannula is positioned at the surgical site, the implant **900** can be urged through the cannula so that the hinged structures **950-953** are clear of the cannula. The rod **915** can then be urged in an opposite direction (relative to insertion) along the longitudinal axis **925** to deploy the second wing **960**. As the rod **915** is drawn through the spacer **920**, the hinged structures **952,953** are drawn toward the spacer **920**. The hinged structures **950-953** pivot outward to accommodate the relative movement between the rod **915** and the spacer **920**. Accordingly, the second wing **960** has been satisfactorily deployed.

Once the second wing **960** is deployed, the cannula **995** can be retracted from the surgical site, thereby allowing the hinged structures **956,957** of the first wing **930** to deploy by urging the hinged structures **956,957** toward the spacer **920**. The urging can be applied by a stop **982** that can fit around the rod **915** and can be interference fit or otherwise selectively fixed with the rod **915**. As the stop **982** is pushed along the longitudinal axis **925**, along the rod **915**, the hinged structures **954-957** pivot outward to accommodate the relative movement between the stop **982** and the spacer **920**. Accordingly, the first wing **930** has been satisfactorily deployed.

Once the second wing **960** and the first wing **930** are deployed, the rod **915** can be fixed in position relative to the spacer **920**. As above, this can be accomplished using myriad different mechanisms. For example, as shown a stop **982** can be interference fit to the rod **915** and positioned against the first wing **930** along the rod **915**. The stop **982** can grip the rod **915** so that the rod **915** is prevented from moving by a friction fit between the stop **982** and the rod **915**. In other embodiments, some other mechanism can be used, such as a pin (e.g., a cotter pin), a latch system, etc. One of ordinary skill in the art will appreciate the myriad different mechanisms for fixing a rod **915** in position relative to the spacer **920**. With the first wing **930**

and the second wing **960** deployed, movement of the implant **900** along the longitudinal axis **925** can be limited or blocked, thereby resisting undesirable displacement of the implant **900**.

It should be noted that with implants as described above in reference to **FIGs. 22A-23B** the rod **915** can optionally be trimmed or otherwise partially detached to decrease a space  
5 required to accommodate the implant **900** within the patient's spine. For example, the structure of the rod **915** can be beveled or otherwise weakened near a distal end of the rod **915** to allow the rod **915** to be snapped off when the first and second wings **930,960** are deployed and the rod **915** is fixed in place. In other embodiments, a tool (not shown) can be used to cut the rod **915** after the first and second wings **930,960** are deployed and the rod **915** is fixed in  
10 place. Still further, the rod **915** need not comprise a rigid structure, but rather alternatively can include a tether, string, or similarly flexible structure that can be placed in tension to retain the second wing **960** and/or first wing **930** in a deployed position.

Referring to **FIGs. 22B, 22C** and **23B**, the implant **900** is shown having operably connected "hinged" structures **950-957**. Such structures can be hinged in any way that  
15 permits relative movement. For example, the structures may be hinged by way of flexible straps, for example as described above in reference to **FIG. 20B**. Alternatively, the structures can be hinged using some other technique. For example, referring to **FIG. 24C**, one or a pair of cords **996** can connect pairs of hinged structures so that relative movement is restricted, thereby permitting hinging motion, while resisting separation of the structures. In still other  
20 embodiments, some other mechanism can be employed to define a range of movement of the hinged structures **950-957**. One of ordinary skill in the art will appreciate the myriad different techniques for defining a range of motion of two mechanical parts.

As with the flexible straps **890** above, the cord **996** can be made from a biocompatible material. In an embodiment, the cord **996** can be made from a braided polyester suture  
25 material. Braided polyester suture materials include, for example, Ethibond, Ethiflex, Mersilene, and Dacron, and are non-absorbable, having high tensile strength, low tissue reactivity and improved handling. In other embodiments, the cords **996** can be made from stainless steel (i.e., surgical steel), which can be woven into a strap, for example. In still other embodiments, the cords **996** can be made from some other material (or combination of



materials) having similar properties.

### **MATERIALS FOR USE IN IMPLANTS OF THE PRESENT INVENTION**

In some embodiments, the implant can be fabricated from medical grade metals such as titanium, stainless steel, cobalt chrome, and alloys thereof, or other suitable implant material having similar high strength and biocompatible properties. Additionally, the implant can be at least partially fabricated from a shape memory metal, for example Nitinol, which is a combination of titanium and nickel. Such materials are typically radiopaque, and appear during x-ray imaging, and other types of imaging. Implants in accordance with the present invention, and/or portions thereof can also be fabricated from somewhat flexible and/or deflectable material. In these embodiments, the implant and/or portions thereof can be fabricated in whole or in part from medical grade biocompatible polymers, copolymers, blends, and composites of polymers. A copolymer is a polymer derived from more than one species of monomer. A polymer composite is a heterogeneous combination of two or more materials, wherein the constituents are not miscible, and therefore exhibit an interface between one another. A polymer blend is a macroscopically homogeneous mixture of two or more different species of polymer. Many polymers, copolymers, blends, and composites of polymers are radiolucent and do not appear during x-ray or other types of imaging. Implants comprising such materials can provide a physician with a less obstructed view of the spine under imaging, than with an implant comprising radiopaque materials entirely. However, the implant need not comprise any radiolucent materials.

One group of biocompatible polymers are the polyaryl ester ketones which has several members including polyetheretherketone (PEEK), and polyetherketoneketone (PEKK). PEEK is proven as a durable material for implants, and meets the criterion of biocompatibility. Medical grade PEEK is available from Victrex Corporation of Lancashire, Great Britain under the product name PEEK-OPTIMA. Medical grade PEKK is available from Oxford Performance Materials under the name OXPEKK, and also from CoorsTek under the name BioPEKK. These medical grade materials are also available as reinforced polymer resins, such reinforced resins displaying even greater material strength. In an embodiment, the implant can be fabricated from PEEK 450G, which is an unfilled PEEK approved for medical implantation

available from Victrex. Other sources of this material include Gharda located in Panoli, India. PEEK 450G has the following approximate properties:

	Property	Value
5	Density	1.3 g/cc
	Rockwell M	99
	Rockwell R	126
	Tensile Strength	97 MPa
	Modulus of Elasticity	3.5 GPa
10	Flexural Modulus	4.1 GPa

PEEK 450G has appropriate physical and mechanical properties and is suitable for carrying and spreading a physical load between the adjacent spinous processes. The implant and/or portions thereof can be formed by extrusion, injection, compression molding and/or machining techniques.

It should be noted that the material selected can also be filled. Fillers can be added to a polymer, copolymer, polymer blend, or polymer composite to reinforce a polymeric material. Fillers are added to modify properties such as mechanical, optical, and thermal properties. For example, carbon fibers can be added to reinforce polymers mechanically to enhance strength for certain uses, such as for load bearing devices. In some embodiments, other grades of PEEK are available and contemplated for use in implants in accordance with the present invention, such as 30% glass-filled or 30% carbon-filled grades, provided such materials are cleared for use in implantable devices by the FDA, or other regulatory body. Glass-filled PEEK reduces the expansion rate and increases the flexural modulus of PEEK relative to unfilled PEEK. The resulting product is known to be ideal for improved strength, stiffness, or stability. Carbon-filled PEEK is known to have enhanced compressive strength and stiffness, and a lower expansion rate relative to unfilled PEEK. Carbon-filled PEEK also offers wear resistance and load carrying capability.

As will be appreciated, other suitable similarly biocompatible thermoplastic or thermoplastic polycondensate materials that resist fatigue, have good memory, are flexible,



and/or deflectable, have very low moisture absorption, and good wear and/or abrasion resistance, can be used without departing from the scope of the invention. As mentioned, the implant can be comprised of polyetherketoneketone (PEKK). Other material that can be used include polyetherketone (PEK), polyetherketoneetherketoneketone (PEKEKK),  
5 polyetheretherketoneketone (PEEKK), and generally a polyaryletheretherketone. Further, other polyketones can be used as well as other thermoplastics. Reference to appropriate polymers that can be used in the implant can be made to the following documents, all of which are incorporated herein by reference. These documents include: PCT Publication WO 02/02158 A1, dated January 10, 2002, entitled "Bio-Compatible Polymeric Materials;" PCT  
10 Publication WO 02/00275 A1, dated January 3, 2002, entitled "Bio-Compatible Polymeric Materials;" and, PCT Publication WO 02/00270 A1, dated January 3, 2002, entitled "Bio-Compatible Polymeric Materials." Other materials such as Bionate®, polycarbonate urethane, available from the Polymer Technology Group, Berkeley, California, may also be appropriate because of the good oxidative stability, biocompatibility, mechanical strength and  
15 abrasion resistance. Other thermoplastic materials and other high molecular weight polymers can be used.

As described above, the binder can be made from a biocompatible material. In an embodiment, the binder can be made from a braided polyester suture material. Braided polyester suture materials include, for example, Ethibond, Ethiflex, Mersilene, and Dacron,  
20 and are nonabsorbable, having high tensile strength, low tissue reactivity and improved handling. In other embodiments, the binder can be made from stainless steel (i.e., surgical steel), which can be braided into a tether or woven into a strap, for example. In still other embodiments, the binder can be made from some other material (or combination of materials) having similar properties.

25 It is to be understood that embodiments in accordance with the present invention can be constructed without a pliant material. It is also to be understood that the embodiments in accordance with the present invention can have other dimensions

## **METHODS FOR IMPLANTING INTERSPINOUS IMPLANTS**

30 A minimally invasive surgical method for implanting an implant 400 in the cervical

spine is disclosed and taught herein. In this method, as shown in **FIG. 24**, preferably a guide wire **80** is inserted through a placement network or guide **90** into the neck of the implant recipient. The guide wire **80** is used to locate where the implant is to be placed relative to the cervical spine, including the spinous processes. Once the guide wire **80** is positioned with the aid of imaging techniques, an incision is made on the side of the neck so that an implant in accordance with an embodiment of the present invention, can be positioned in the neck thorough an incision and along a line that is about perpendicular to the guide wire **80** and directed at the end of the guide wire **80**. In one embodiment, the implant can be a sized implant **400** (i.e., having a body that is not distractable), such as described above in **FIGs. 1-17** and including a distraction guide **110**, a spacer **120**, and a first wing **130**. The implant **400** is inserted into the neck of the patient. Preferably during insertion, the distraction guide **110** pierces or separates the tissue without severing the tissue.

Once the implant **400** is satisfactorily positioned, a second wing **460** can be optionally inserted along a line that is generally colinear with the line over which the implant **400** is inserted but from the opposite side of the neck. The anatomy of the neck is such that it is most convenient and minimally invasive to enter the neck from the side with respect to the implant **400** and the second wing **460**. The second wing **460** is mated to the implant and in this particular embodiment, the second wing **460** is attached to the implant **400** by the use of a fastener, for example by a screw **442**. Where a screw is used, the screw **442** can be positioned using a screw driving mechanism that is directed along a posterior to anterior line somewhat parallel to the guide wire **80**. This posterior to anterior line aids the physician in viewing and securing the second wing **460** to the implant. The second wing **460** is positioned so that a bore **463** formed in a lip **461** of the second wing **460** is aligned with a bore **440** of the implant **400**, as described above. The screw **442** is positioned within both bores and secured, at least, to the bore **440** of the implant **400**. In other embodiments, the second wing can be interference fit with the implant, as described above, or fastened using some other mechanism, such as a flexible hinge and protrusion.

A minimally invasive surgical method for implanting an alternative embodiment of an implant **700** in the cervical spine is disclosed and taught herein. In this method, as shown in



**FIG. 25**, preferably a guide wire **80** is inserted through a placement network or guide **90** into the neck of the implant recipient. The guide wire **80** is used to locate where the implant **700** is to be placed relative to the cervical spine, including the spinous processes. Once the guide wire **80** is positioned with the aid of imaging techniques, an incision is made on the side of the neck so that an implant **700** in accordance with an embodiment of the present invention, can be positioned in the neck thorough an incision and along a line that is about perpendicular to the guide wire **80** and directed at the end of the guide wire **80**. In an embodiment, the implant **700** can include a distraction guide **710**, a spacer **720**, a rod **715** extending through the spacer **720**, and deployable first and second wings **730,760**. The implant **700** can have a substantially flat profile to ease implantation, as described above. The implant **700** is inserted into the neck of the patient. Preferably during insertion, the distraction guide **710** pierces or separates the tissue without severing the tissue.

Once the implant **700** is satisfactorily positioned, the first wing **730** and the second wing **760** can be deployed. As described above, the second wing **760** can be deployed by urging the rod **715** in a direction opposite the direction of insertion along the longitudinal axis **725**. As the rod **715** travels through the spacer **720**, hinged structures **750-753** contact the spacer **720**, buckle and extend away from the rod **715** two form an upper end **762** of the second wing and a lower end **764** of the second wing. When second wing **760** is satisfactorily deployed, the rod **715** can be fixed in place relative to the spacer **720** using a first stop **782**, a pin, or some other mechanism. The first wing **730** can be deployed by urging the hinged structures **754-757** toward the spacer **720**, causing the hinged structures **754-757** to buckle and extend away from one another to form an upper end **732** of the second wing and a lower end **734** of the second wing. The anatomy of the neck is such that it is most convenient and minimally invasive to enter the neck from the side with respect to the implant **700**.

A minimally invasive surgical method for implanting an alternative embodiment of an implant **900** in the cervical spine is disclosed and taught herein. In this method, as shown in **FIG. 26**, preferably a guide wire **80** is inserted through a placement network or guide **90** into the neck of the implant recipient. The guide wire **80** is used to locate where the implant **900** is to be placed relative to the cervical spine, including the spinous processes. Once the guide

wire **80** is positioned with the aid of imaging techniques, an incision is made on the side of the neck along a line that is about perpendicular to the guide wire **80** and directed at the end of the guide wire **80**. The cannula **995** is fed through the incision and positioned between the targeted adjacent spinous processes. In an embodiment, the implant **900** can include a distraction guide **910**, a spacer **920**, a rod **915** extending through the spacer **920**, and deployable first and second wings **930,960**. The implant **900** can have a substantially circular cross-section to roughly conform with an inside surface of the cannula **995**. The implant **900** is urged through the cannula **995** and into position between the adjacent spinous processes so that the second wing **960** hinge structures are clear of the cannula **995**, as described above in reference to **FIG. 23B**. The second wing **960** is then deployed by urging the rod **915** in a direction opposite the direction of insertion along the longitudinal axis **925**. As the rod **915** travels through the spacer **920**, hinged structures **950-953** contact the spacer **920**, buckle and extend away from the rod **915** to form an upper end **962** of the second wing and a lower end **964** of the second wing. When second wing **960** is satisfactorily deployed, the cannula **995** can be retracted to expose the hinged structures **954-957** of the first wing **930**. The first wing **930** can be deployed by urging the hinged structures **954-957** toward the spacer **920**, causing the hinged structures **954-957** to buckle and extend away from one another to form an upper end **932** of the second wing and a lower end **934** of the second wing. Once the first wing **930** is deployed, the rod **915** can optionally be shortened, and the cannula **995** can be withdrawn from the incision. The incision can then be closed.

The foregoing description of the present invention have been presented for purposes of illustration and description. It is not intended to be exhaustive or to limit the invention to the precise forms disclosed. Many modifications and variations will be apparent to practitioners skilled in this art. The embodiments were chosen and described in order to best explain the principles of the invention and its practical application, thereby enabling others skilled in the art to understand the invention for various embodiments and with various modifications as are suited to the particular use contemplated. It is intended that the scope of the invention be defined by the following claims and their equivalents.



**WHAT IS CLAIMED:**

1. An interspinous implant adapted to be inserted between spinous processes, the implant comprising:
  - 5 a spacer having a thickness; and
  - a wing extending from the spacer, the wing having a first configuration and the wing selectably arrangeable in a second configuration;
    - wherein in the first configuration the wing has a height that is approximately the same as the thickness of the spacer;
    - 10 wherein in the second configuration the wing has a height that is greater than the thickness of the spacer.
2. The implant of claim 1, further comprising:
  - 15 a rod extending through the spacer, the rod being used to selectably arrange the wing to the first configuration and the second configuration when moved relative to the spacer.
3. The implant of claim 1, wherein:
  - 20 the wing is a second wing; and
  - the implant further comprises:
    - a first wing extending from the spacer, the first wing having a first configuration and the first wing selectably arrangeable in a second configuration.
4. The implant of claim 3, wherein:
  - 25 in the first configuration the first wing has a height that is approximately the same as the thickness of the spacer;
  - in the second configuration the first wing has a height that is greater than the thickness of the spacer.
- 30 5. The implant of claim 1, wherein in the first configuration the wing is a distraction

guide.

6. The implant of claim 1, wherein:

the wing includes one or both of an upper end having a first upper hinged structure  
5 pivotably connected with a second upper hinged structure and a lower end having a first  
lower hinged structure pivotably connected with a second lower hinged structure.

7. The implant of claim 2, wherein the rod is fixed in place relative to the spacer by at  
least one of a pin, a stop, and a clamp.

10

8. The implant of claim 6, further comprising:

one or both of:

a first strap connected between the first upper hinged structure and the second  
upper hinged structure, the first strap being adapted to limit the pivoting motion of the first  
15 upper hinged structure relative to the second upper hinged structure, and

a second strap connected between the first lower hinged structure and the second  
lower hinged structure, the second strap being adapted to limit the pivoting motion of the  
first lower hinged structure and the second lower hinged structure.

20 9. A system for supporting adjacent spinous processes, the system comprising:  
an implant including:

a spacer having a thickness;

a wing;

wherein a first configuration of the wing has a first height substantially  
25 similar to the thickness;

wherein the wing is adapted to be selectably arranged in a second  
configuration such that the wing has a second height greater than the first height;

a cannula having a proximate end positionable between the adjacent spinous  
processes; and



wherein when the wing is arranged in the first configuration a periphery of the implant has a shape generally conformal with a shape of an inner surface of the cannula and a cross-sectional diameter smaller than an inner diameter of the cannula.

- 5 10. The implant of claim 9, further comprising:  
a rod extending through the spacer, the rod being adapted to selectably arrange at least the second wing to the first configuration and the second configuration when moved relative to the spacer.
- 10 11. The implant of claim 9, wherein:  
the wing is a second wing; and  
the implant further comprises:  
a first wing extending from the spacer, the first wing having a first configuration and the first wing selectably arrangeable in a second configuration.
- 15 12. The implant of claim 11, wherein:  
in the first configuration the first wing has a height that is approximately the same as the thickness of the spacer;  
in the second configuration the first wing has a height that is greater than the  
20 thickness of the spacer.
13. The implant of claim 9, wherein in the first configuration the second wing is tapered such that the second wing is a distraction guide.
- 25 14. The implant of claim 9, wherein:  
the first and second wing include one or both of an upper end having a first upper hinged structure pivotably connected with a second upper hinged structure and a lower end having a first lower hinged structure pivotably connected with a second lower hinged structure.

15. The implant of claim 10, wherein the rod is fixed in place relative to the spacer by at least one of a pin, a stop, and a clamp.

16. The implant of claim 14, further comprising:

5 one or both of:

a first strap connected between the first upper hinged structure and the second upper hinged structure, the first strap being adapted to limit the pivoting motion of the first upper hinged structure relative to the second upper hinged structure, and

10 a second strap connected between the first lower hinged structure and the second lower hinged structure, the second strap being adapted to limit the pivoting motion of the first lower hinged structure and the second lower hinged structure.

17. A method of arranging an implant between adjacent spinous processes, the method comprising:

15 inserting a proximal end of a cannula at a surgical site;

positioning the proximal end between the adjacent spinous processes;

20 positioning an implant between the adjacent spinous processes by urging the implant through the cannula, the implant including a spacer having a thickness, and a wing, wherein a first configuration of the wing has a first height substantially similar to the thickness;

urging the implant at least partially past the proximal end such that the spacer is arranged between the adjacent spinous processes;

rearranging the wing to a second configuration such that the wing has a second height greater than the first height;

25 withdrawing the cannula from the surgical site.

18. The method of claim 17, wherein the wing is a second wing, and the implant further includes a first wing wherein a first configuration of the first wing has a first height substantially similar to the thickness;

30 the method further comprising:



withdrawing the cannula so that the first wing is exposed to the surgical site;  
rearranging the first wing to a second configuration such that the wing has a  
second height greater than the first height.

- 5 19. The method of claim 18, wherein rearranging the wing to a second configuration  
includes urging a rod operably associated with the implant in a direction opposite the  
direction of urging while generally maintaining the implant in position.
20. The method of claim 19, further comprising:
- 10 fixing the rod in place, thereby maintaining the wing in the second configuration.

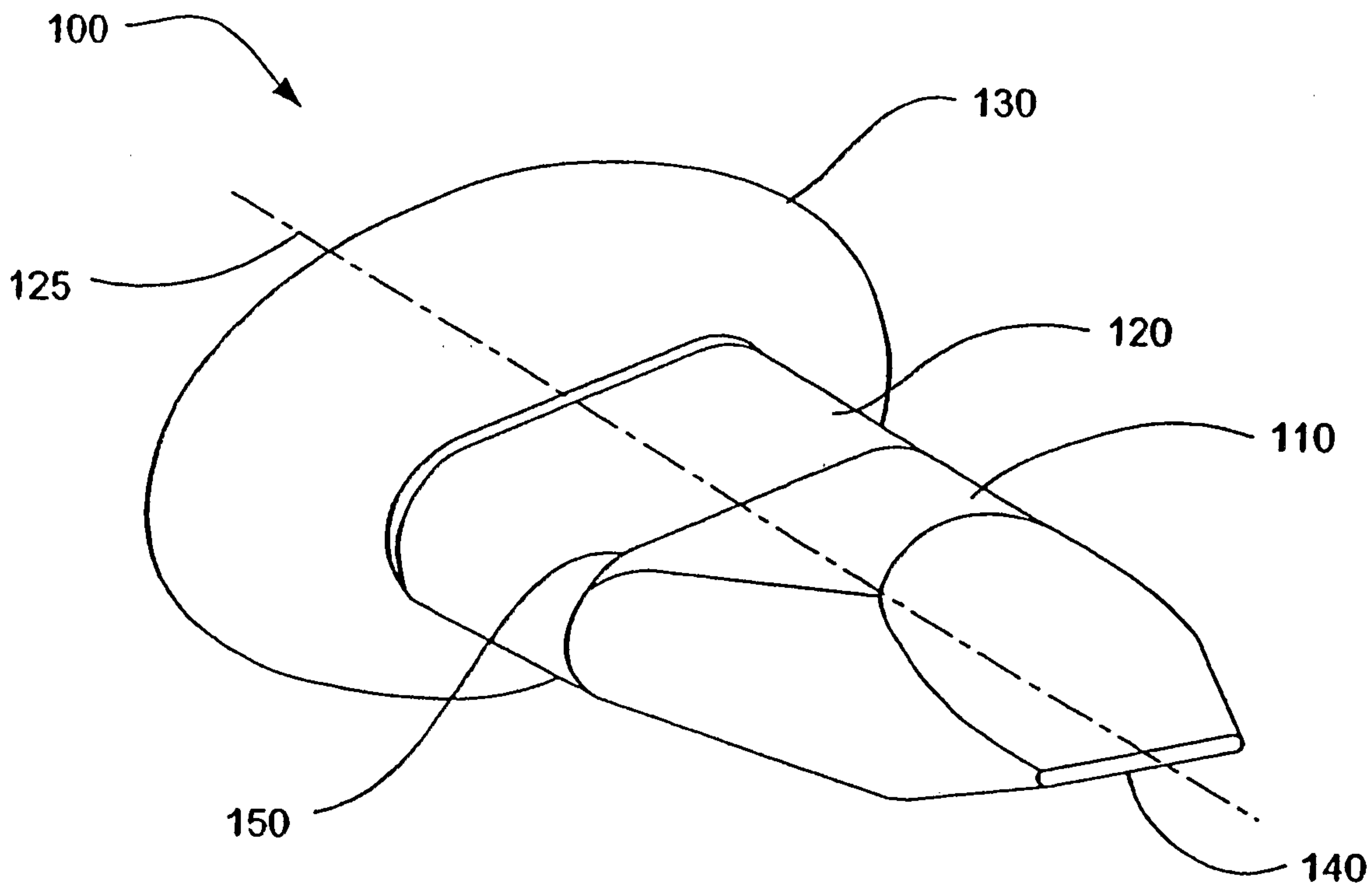

FIG. - 1

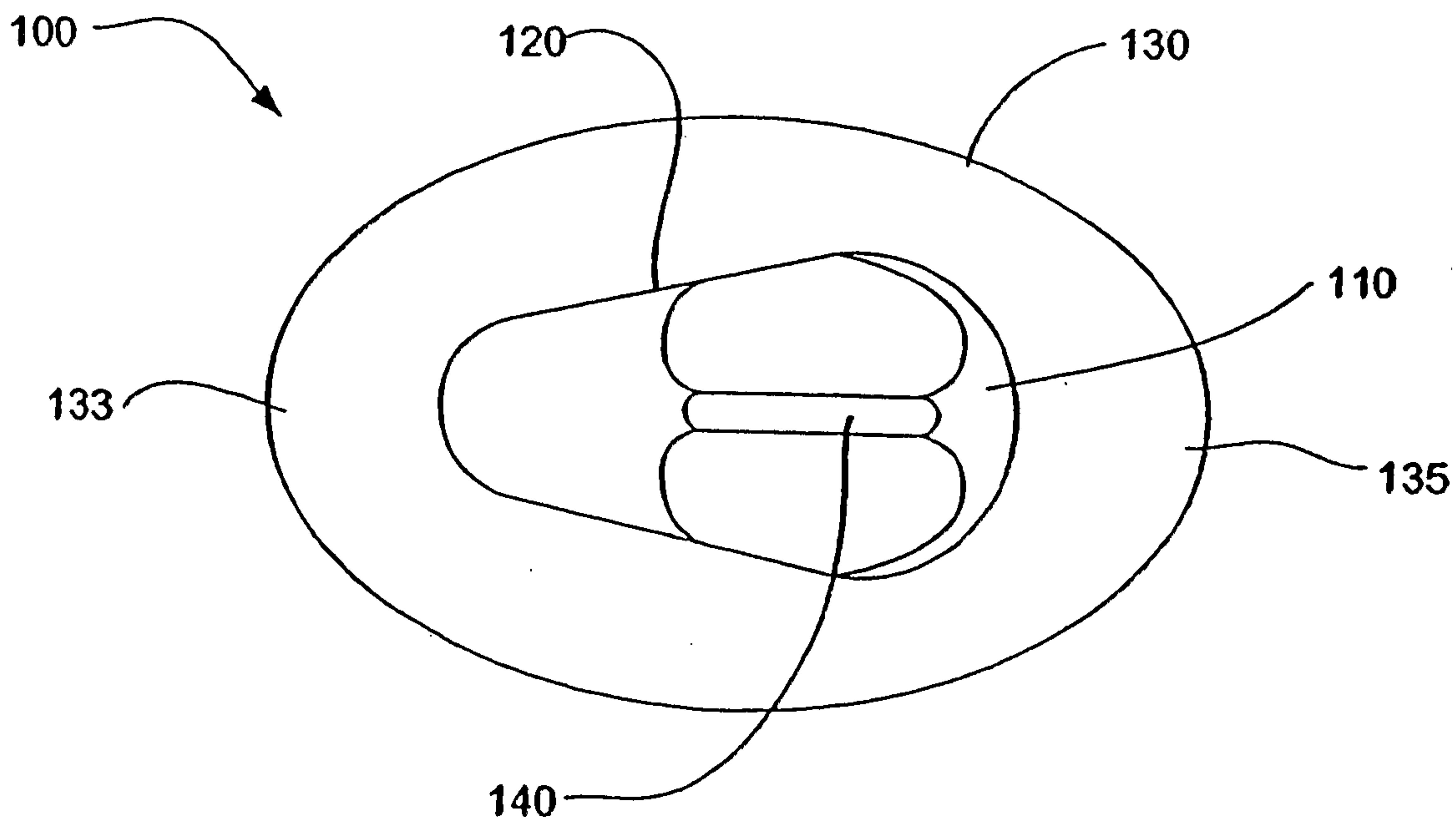

FIG. - 2



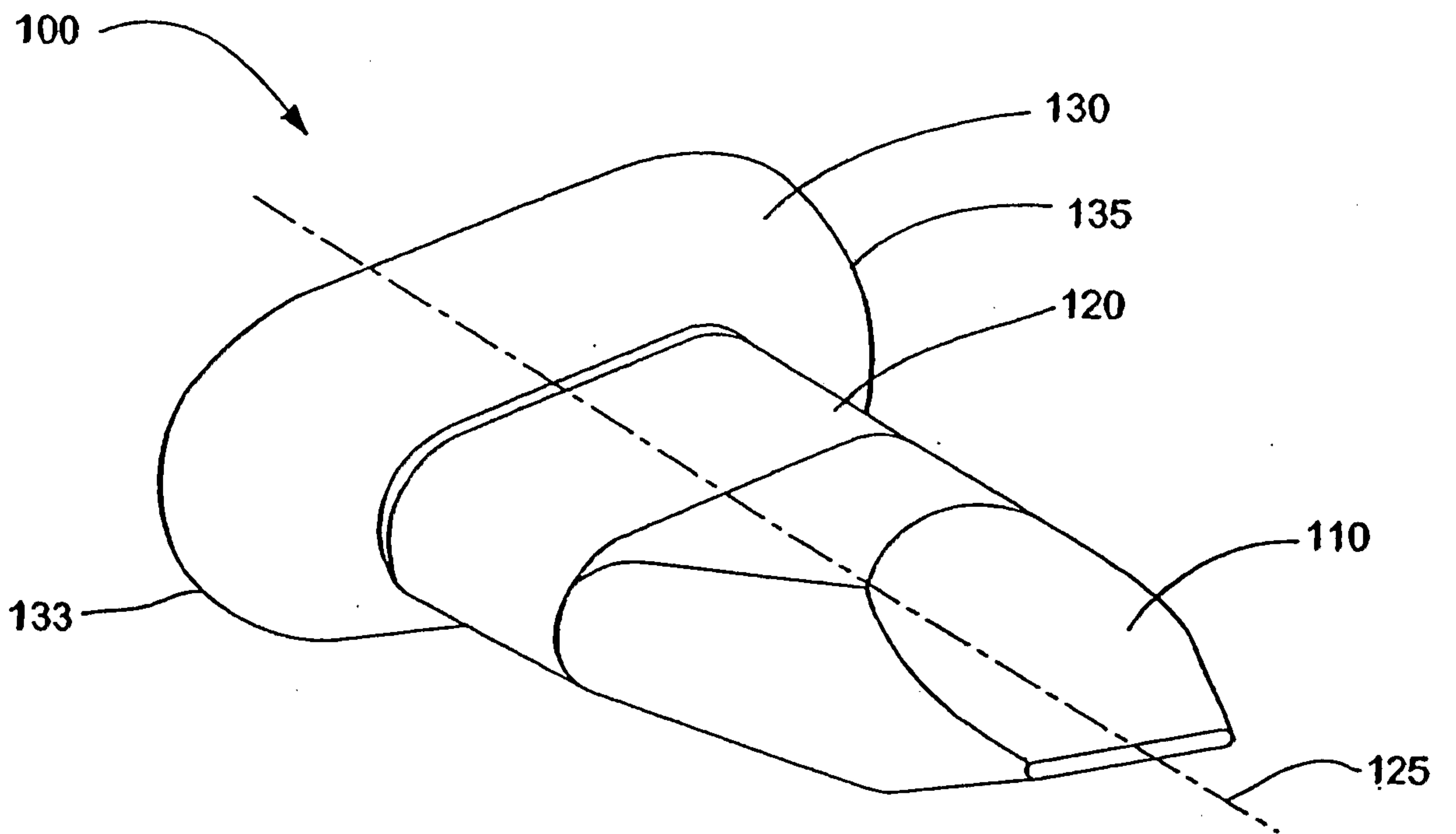

FIG. - 3

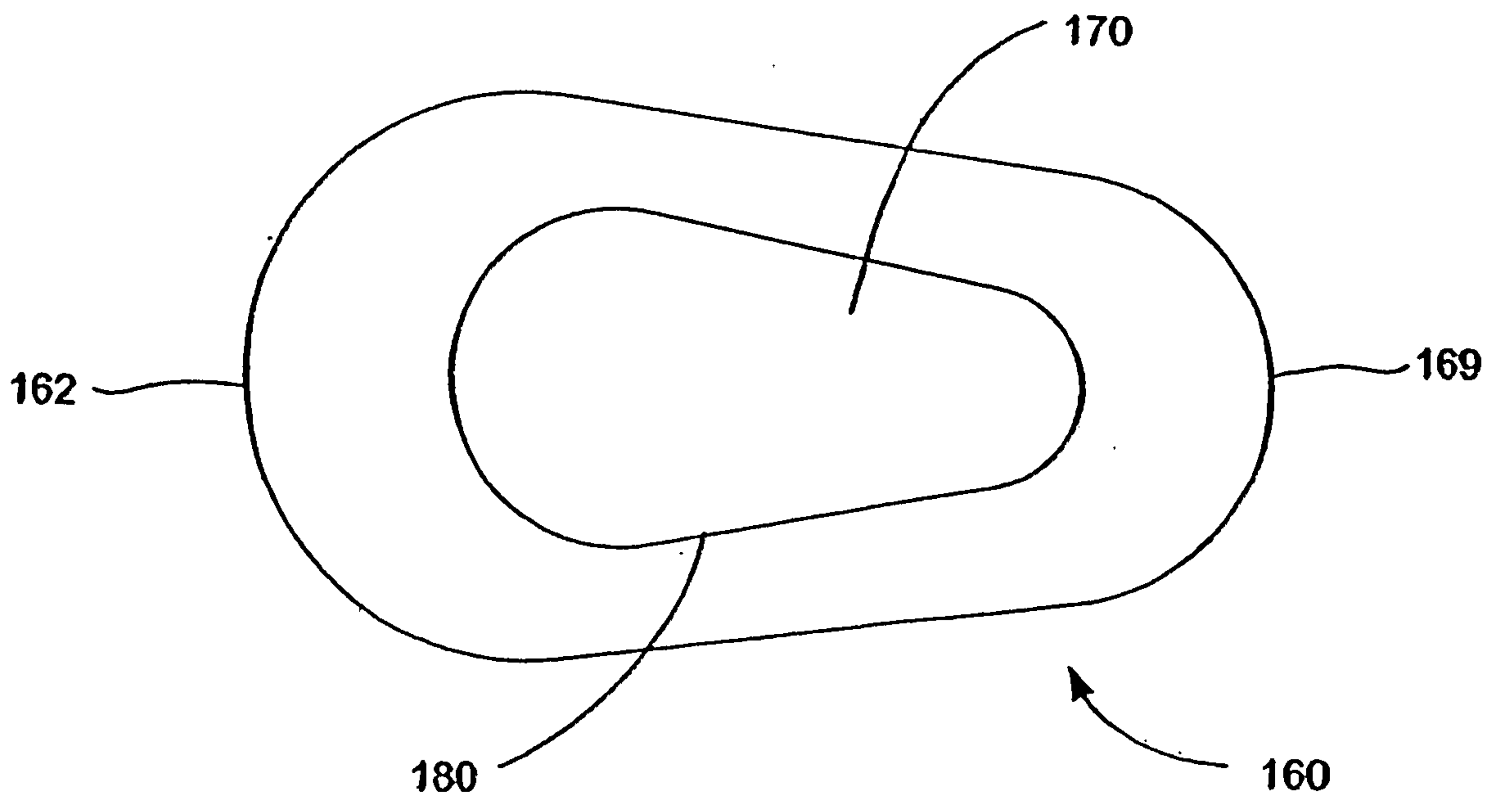

FIG. - 4

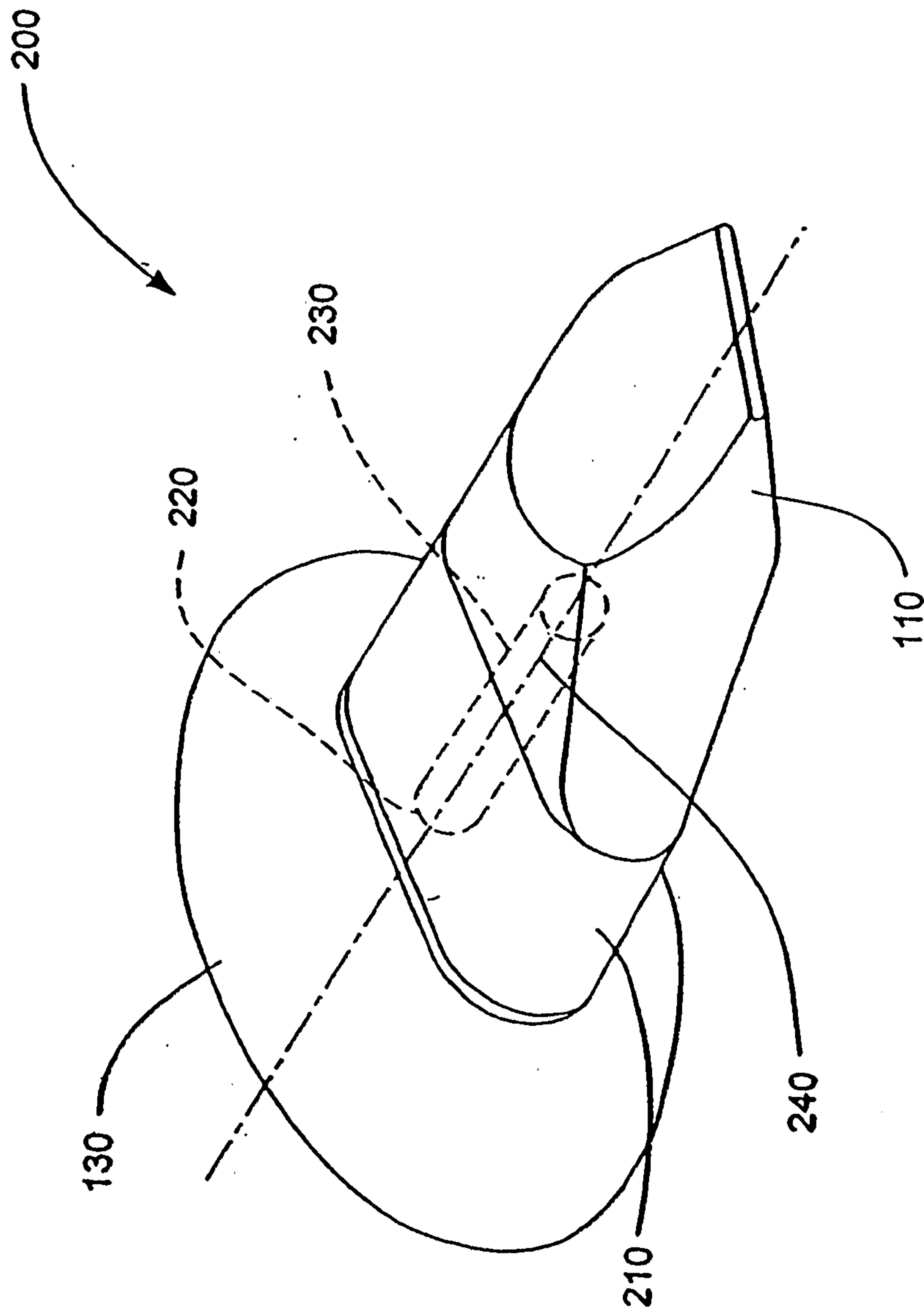

FIG. - 5



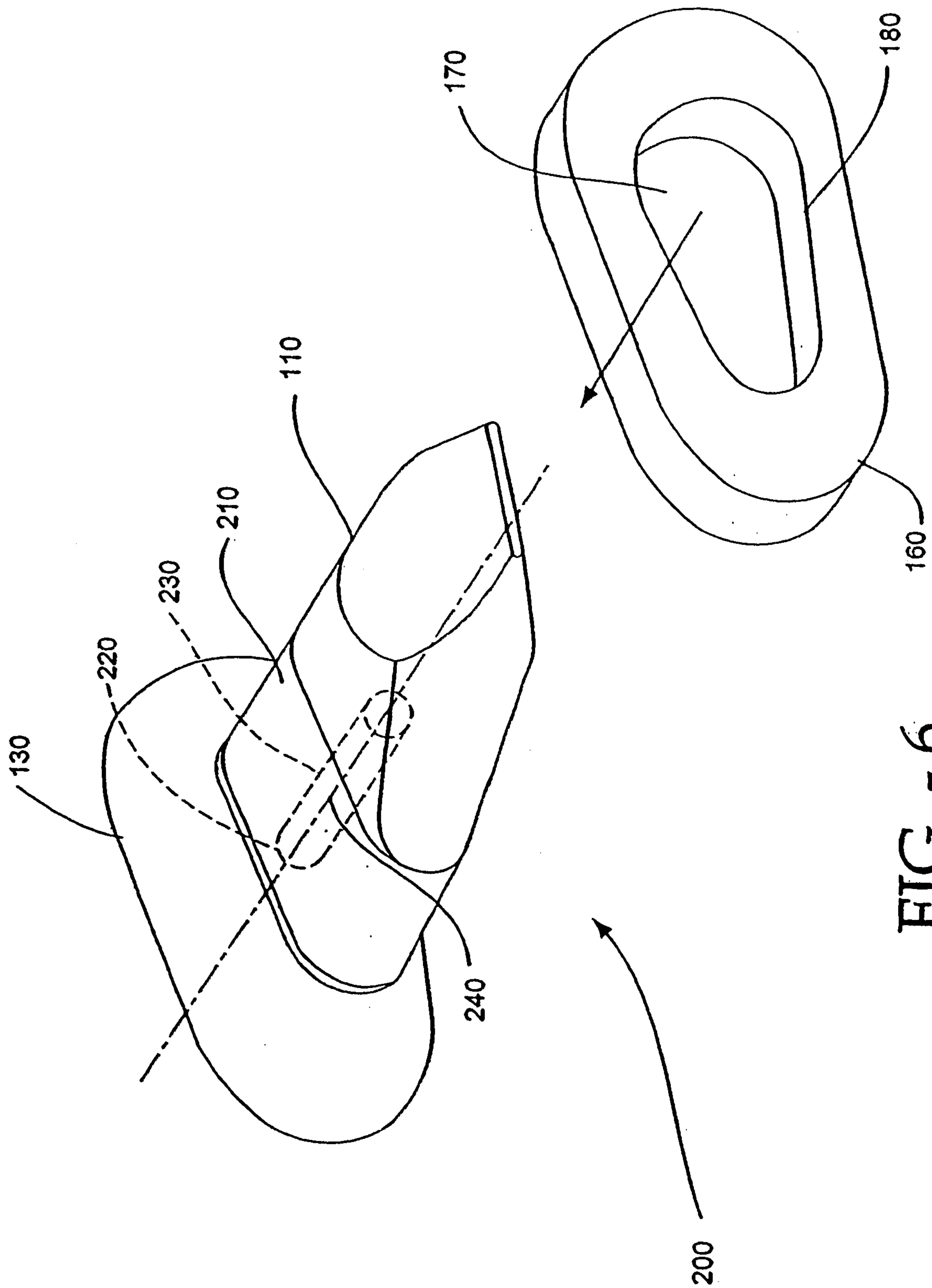

FIG. - 6

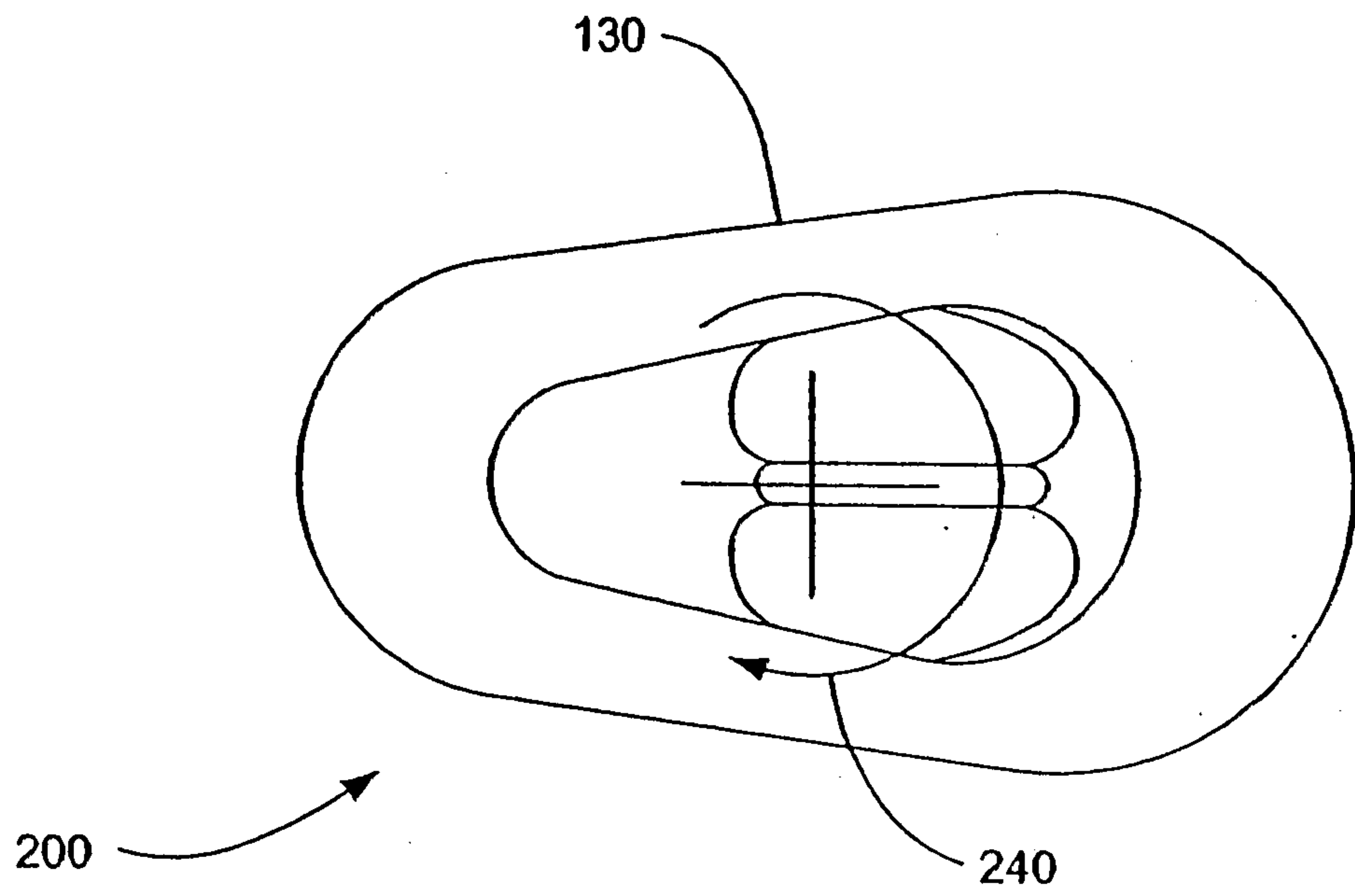

FIG. - 7



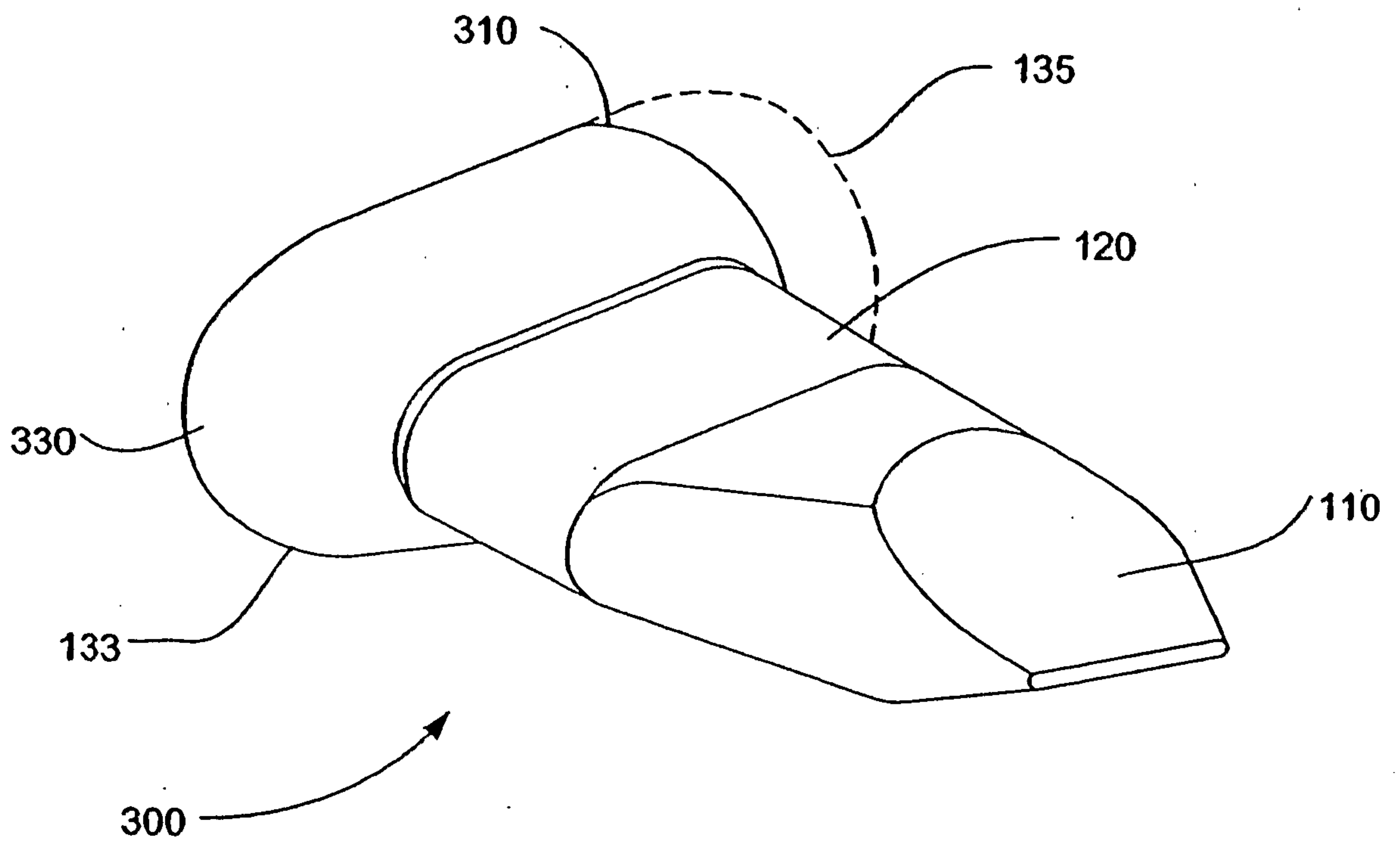

FIG. - 8

7/26

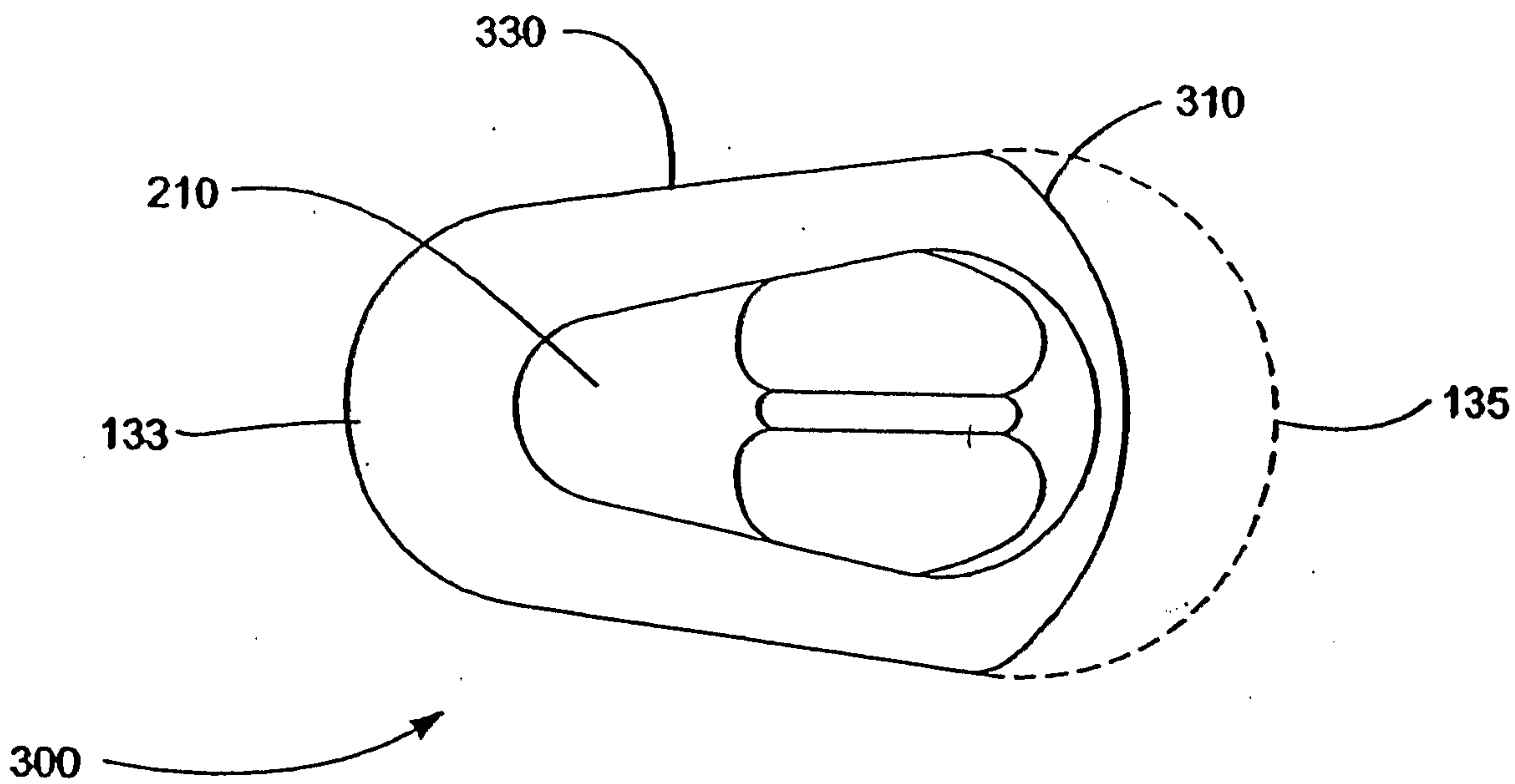

FIG. - 9A

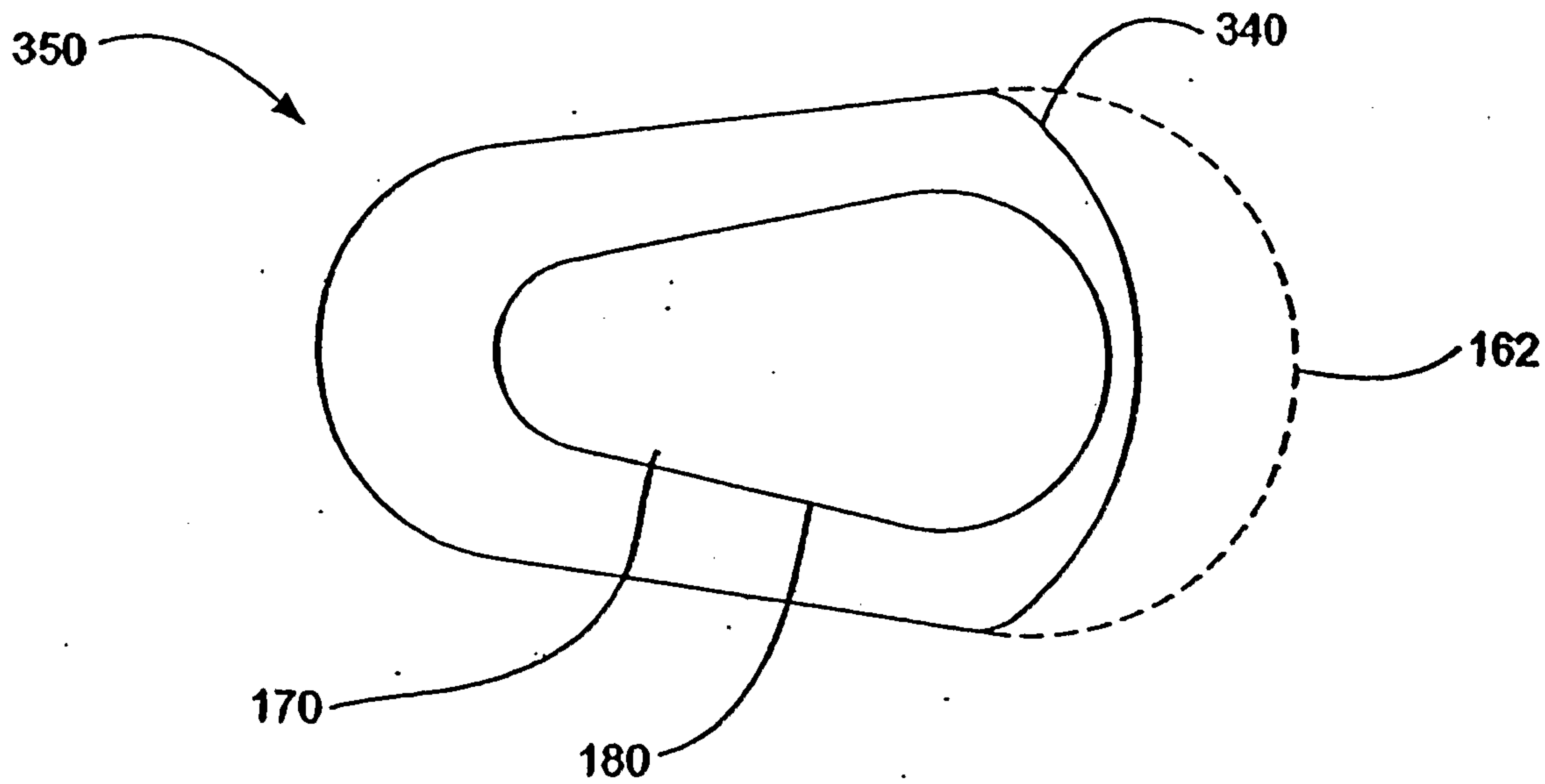

FIG. - 9B



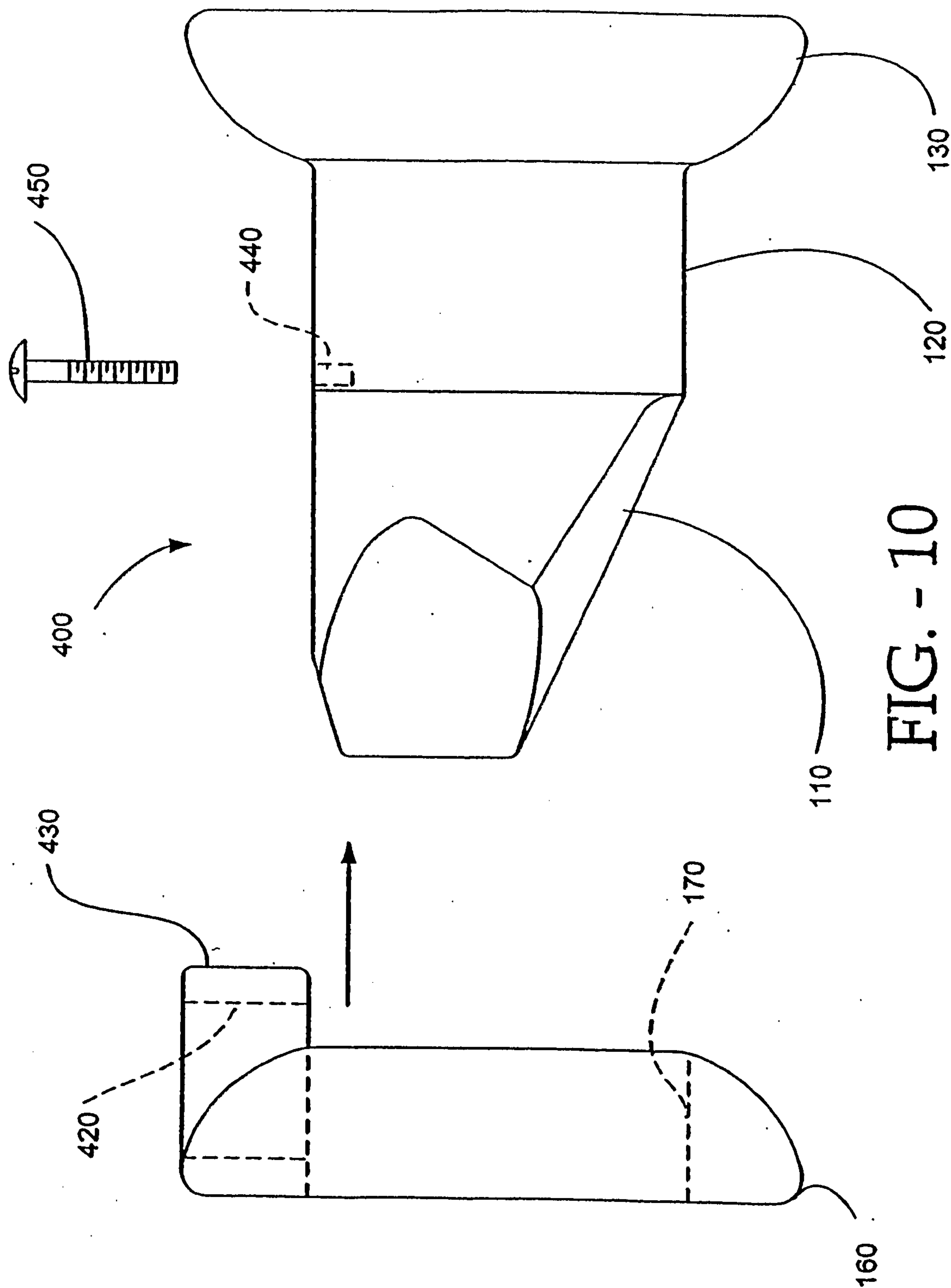

FIG. - 10

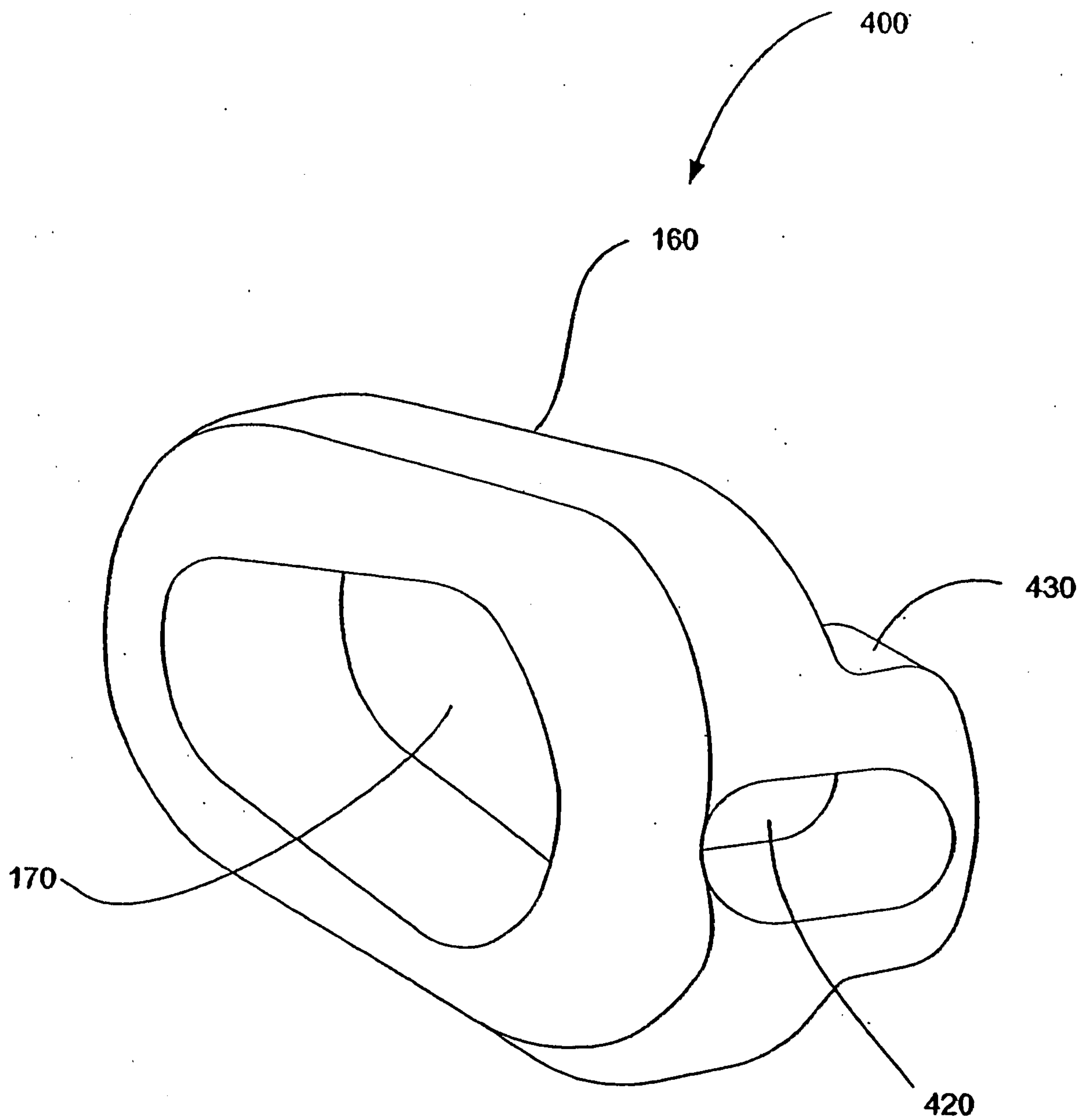

FIG. - 11



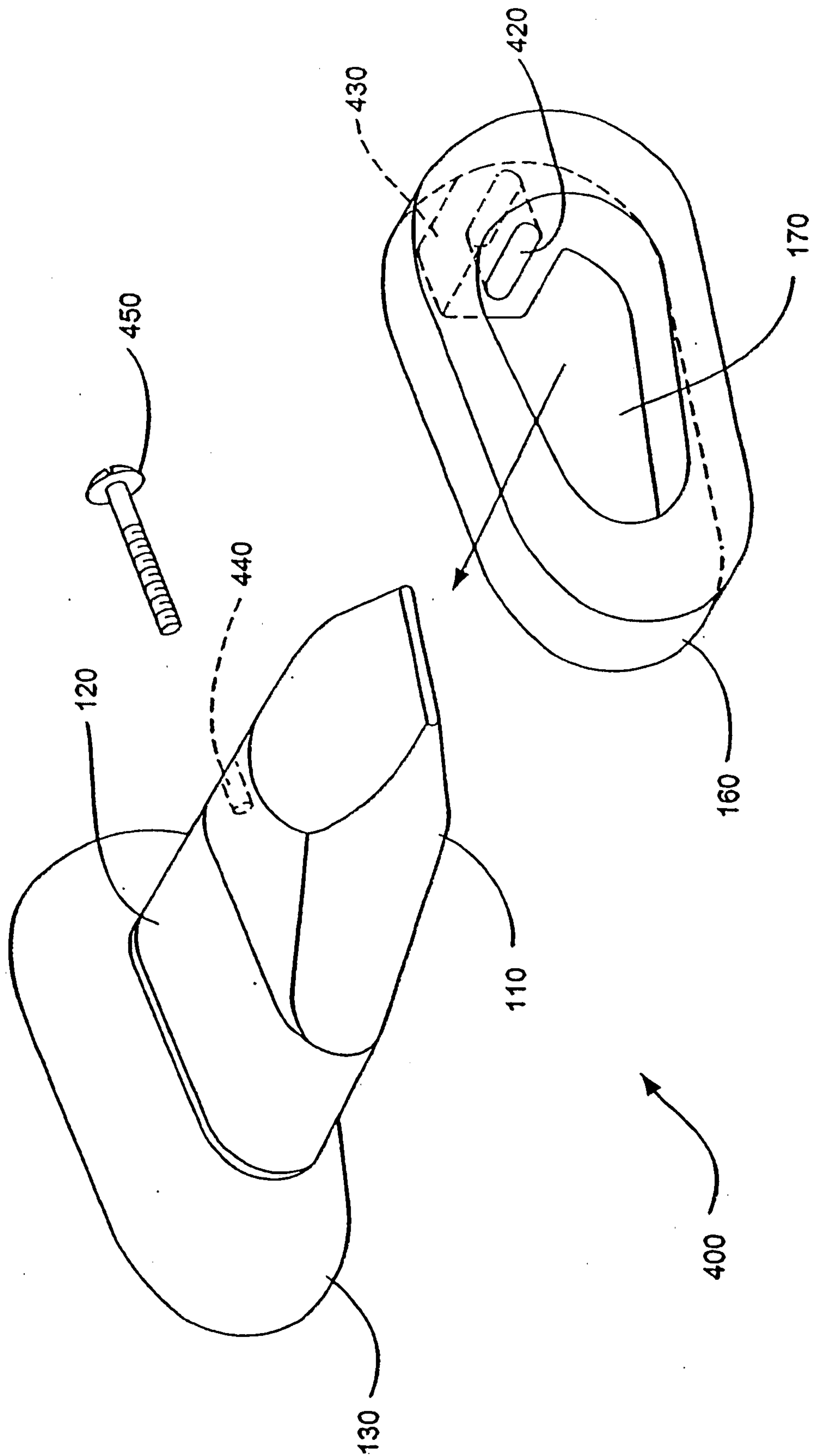

FIG. - 12

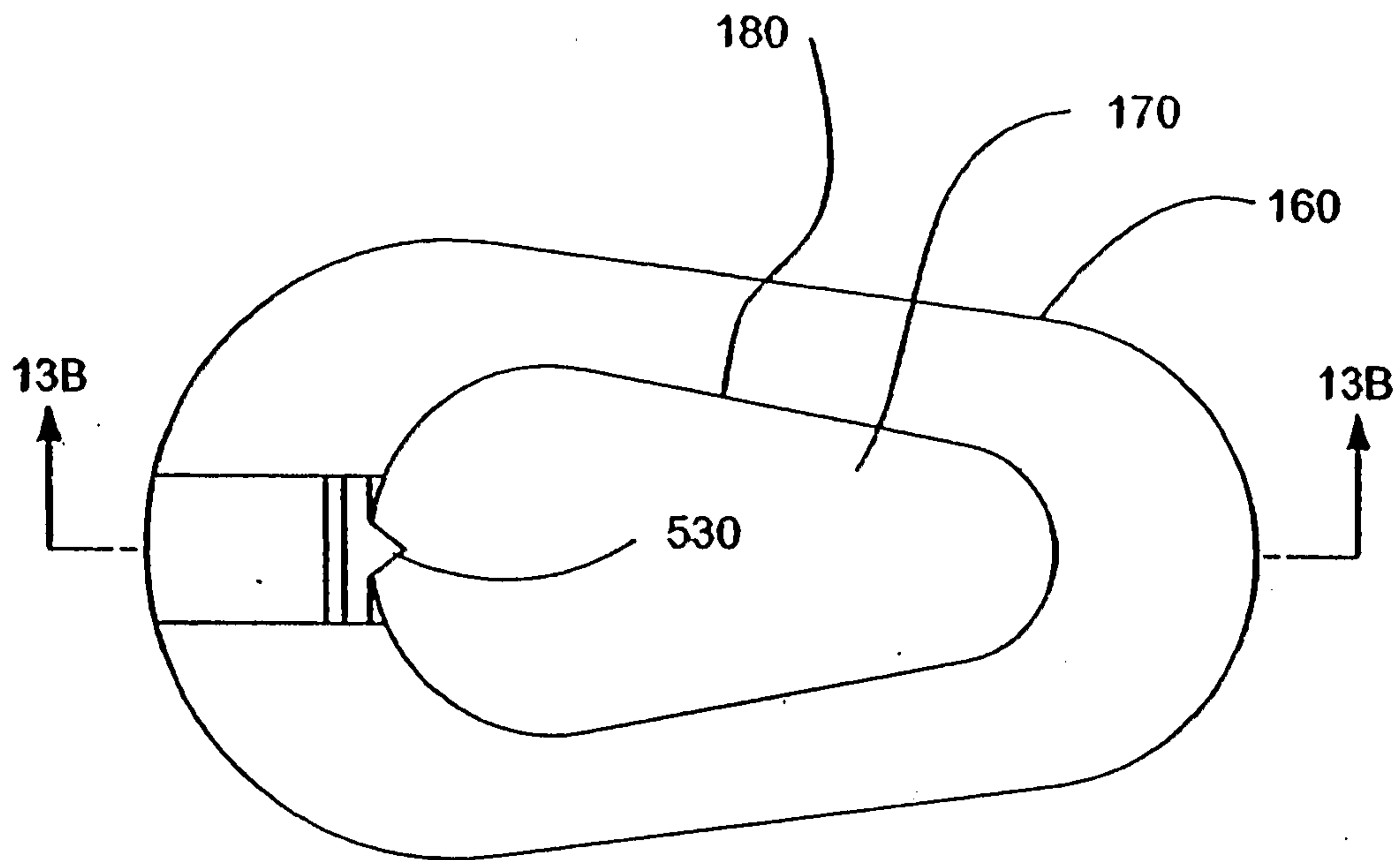

FIG. - 13A

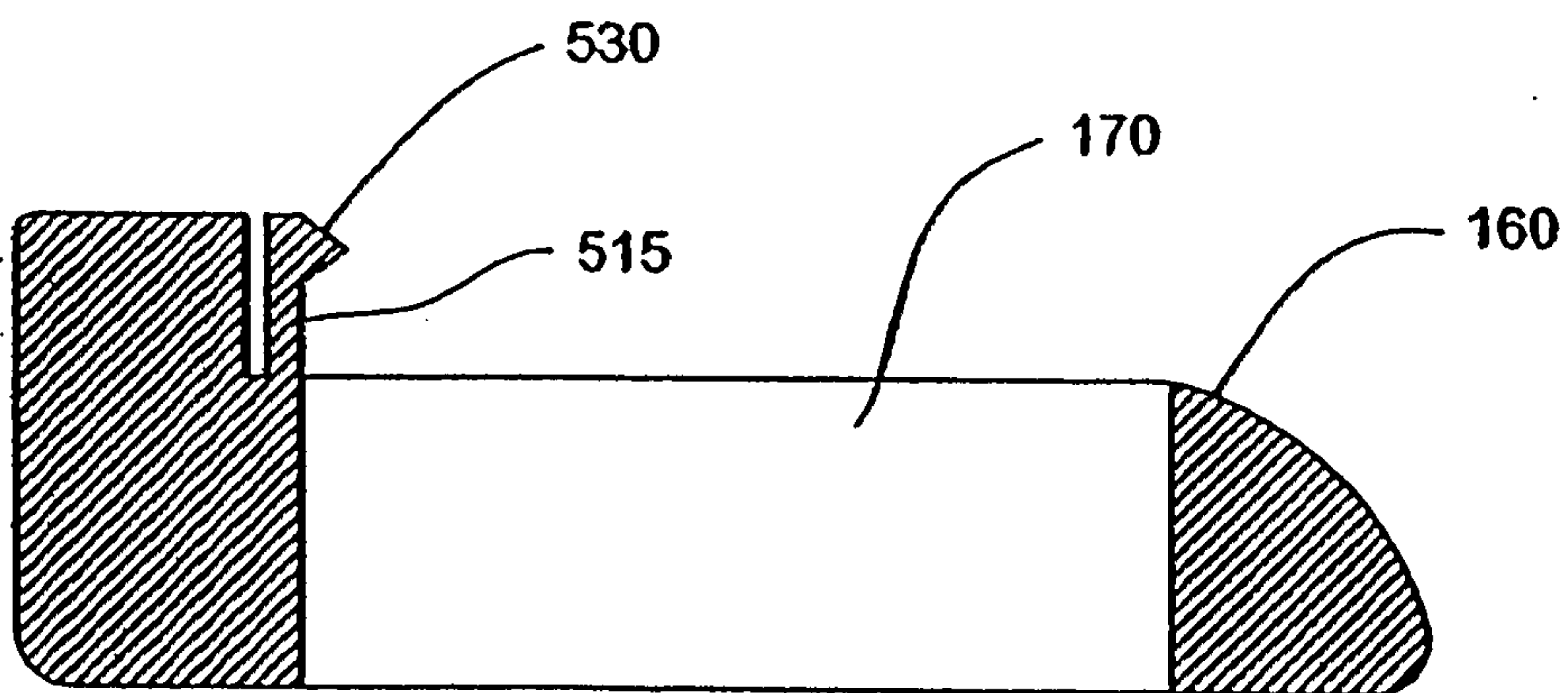

FIG. - 13B



12/26

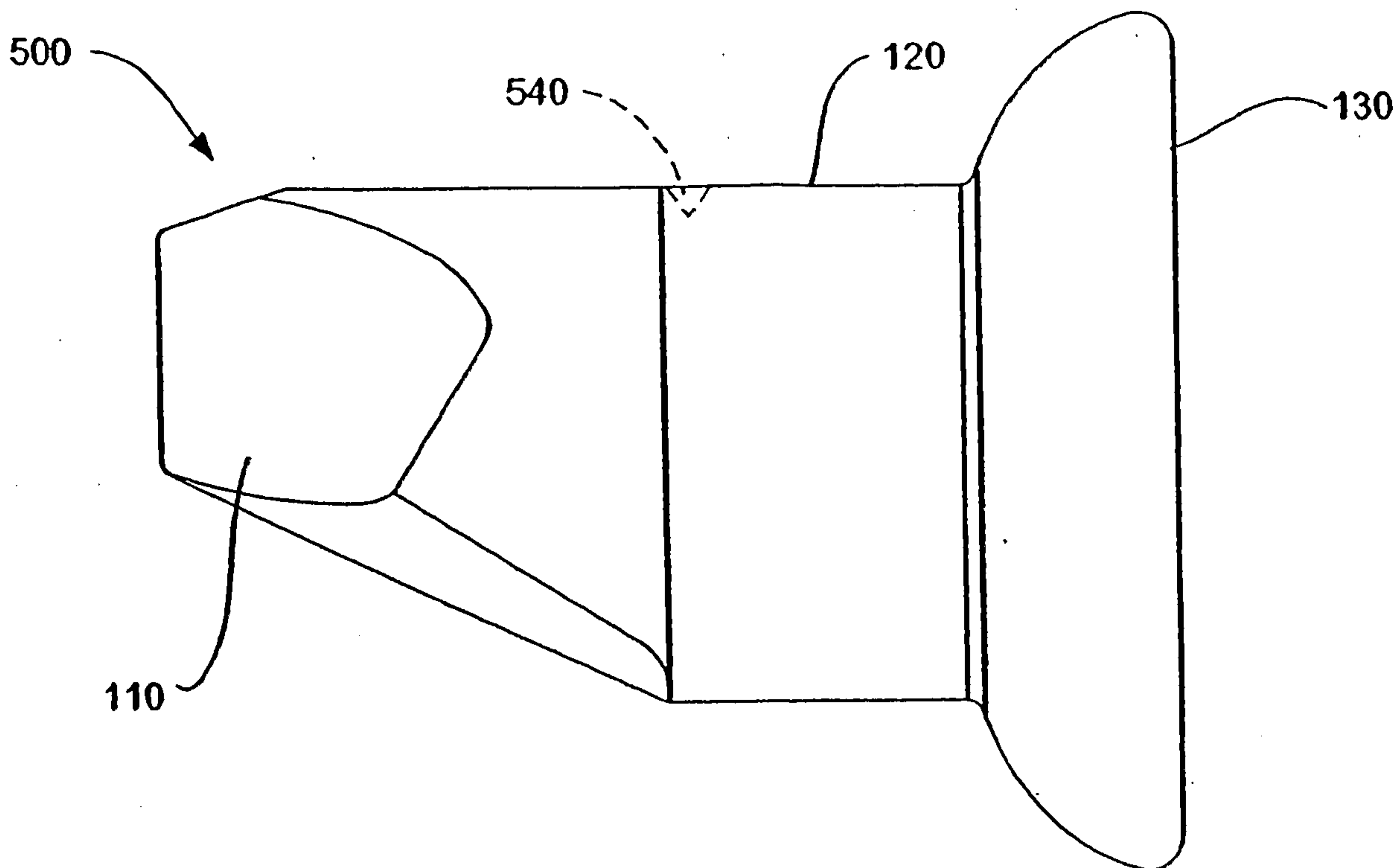

FIG. - 14A

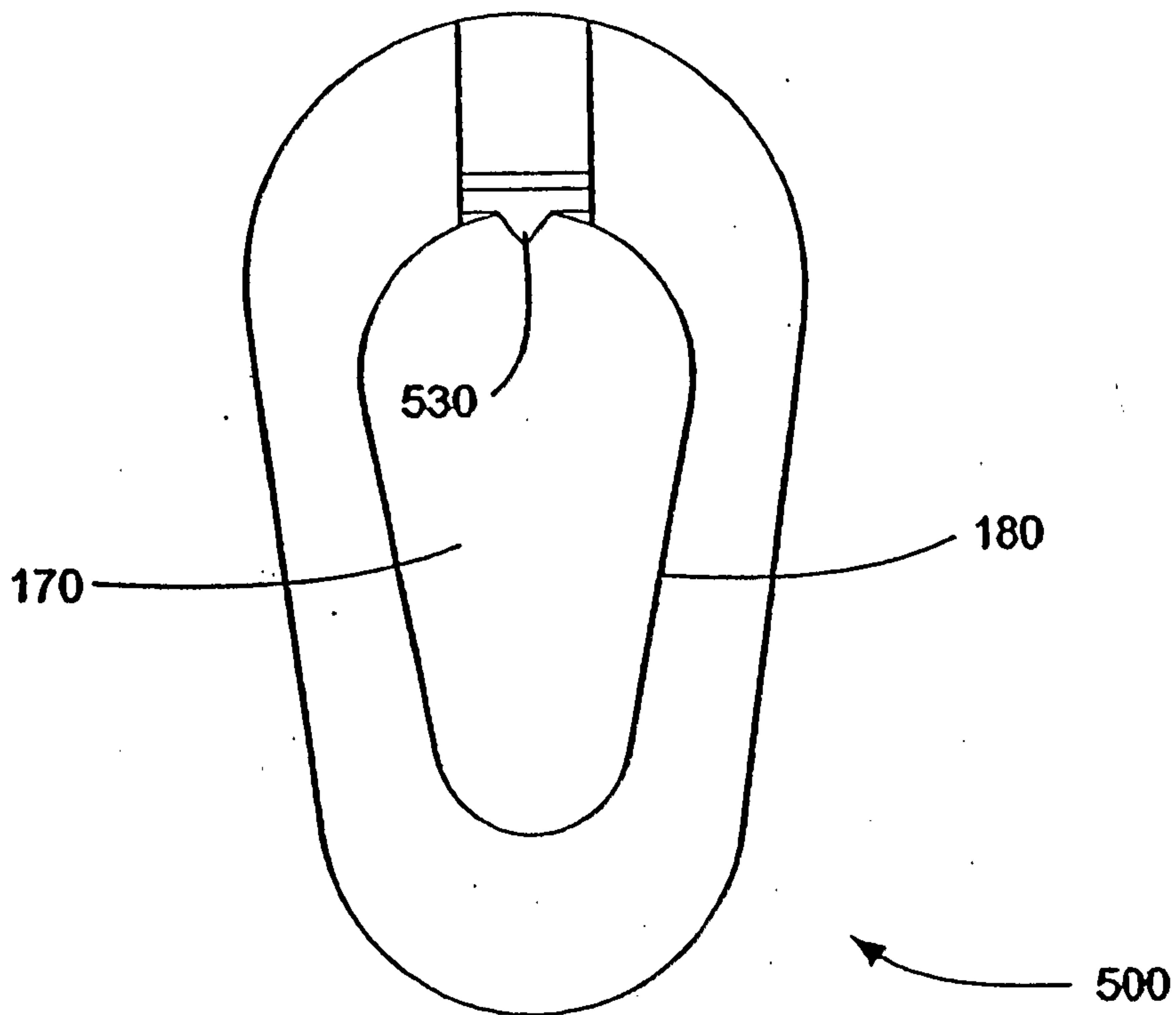

FIG. - 14B

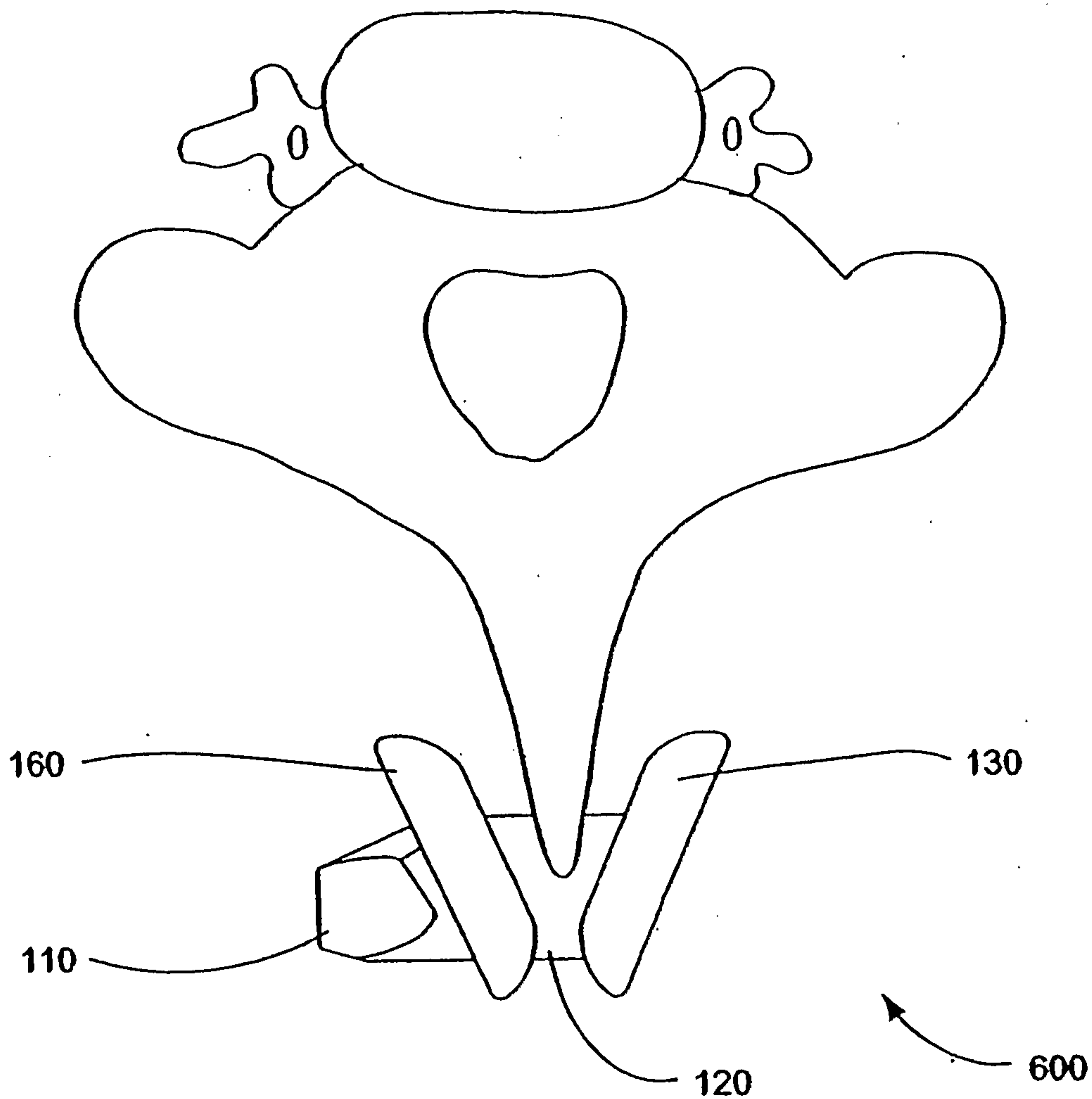

FIG. - 15A

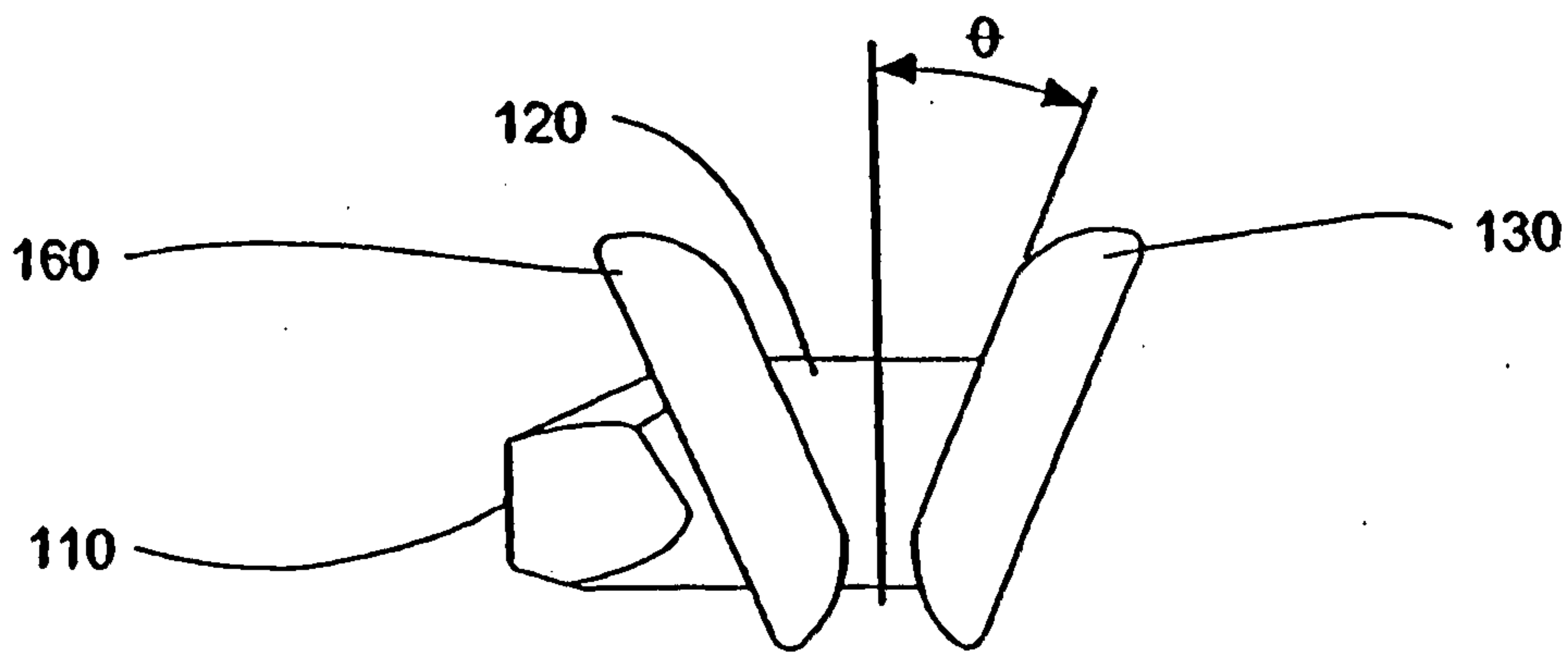

FIG. - 15B



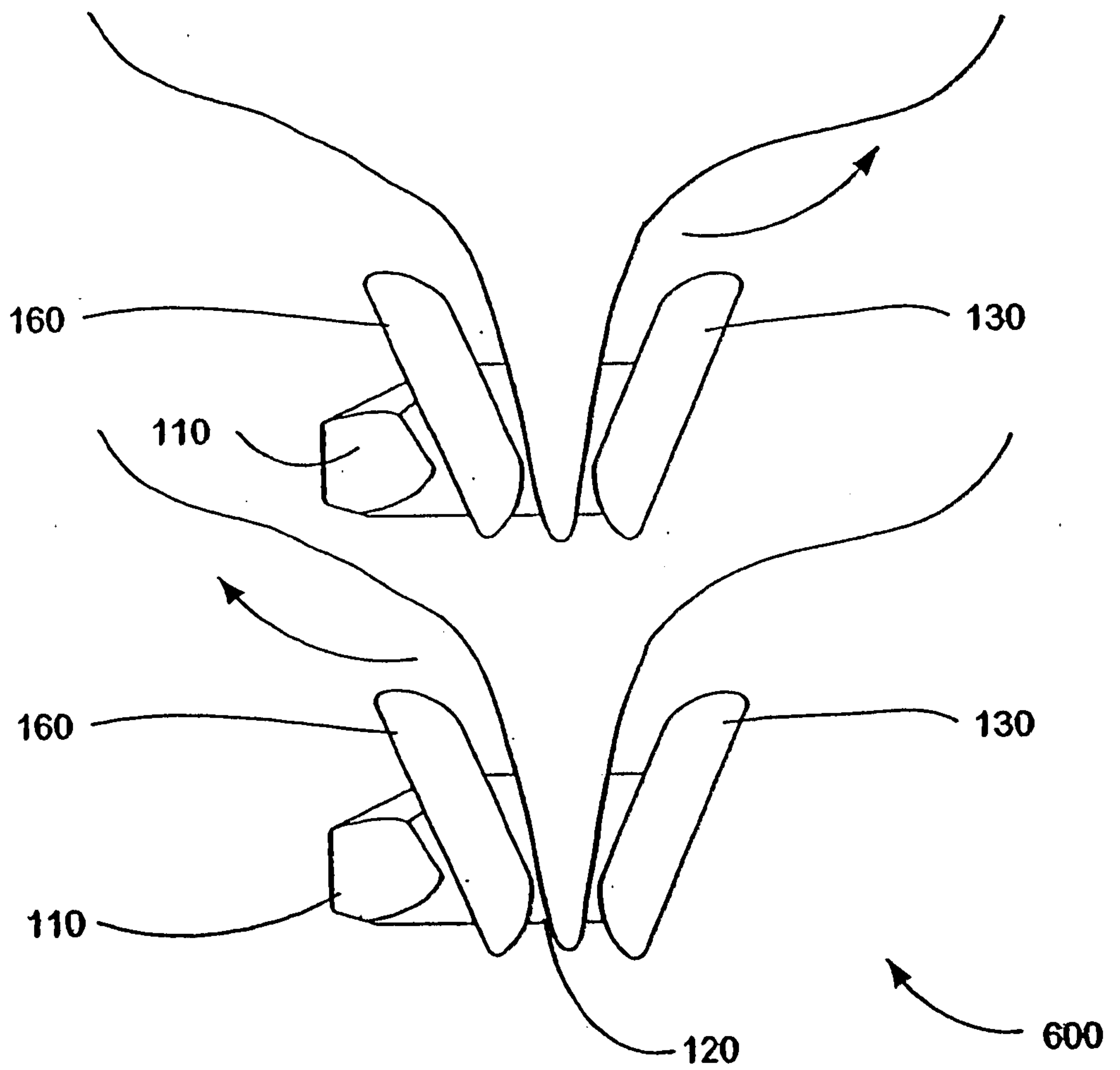

FIG. - 16

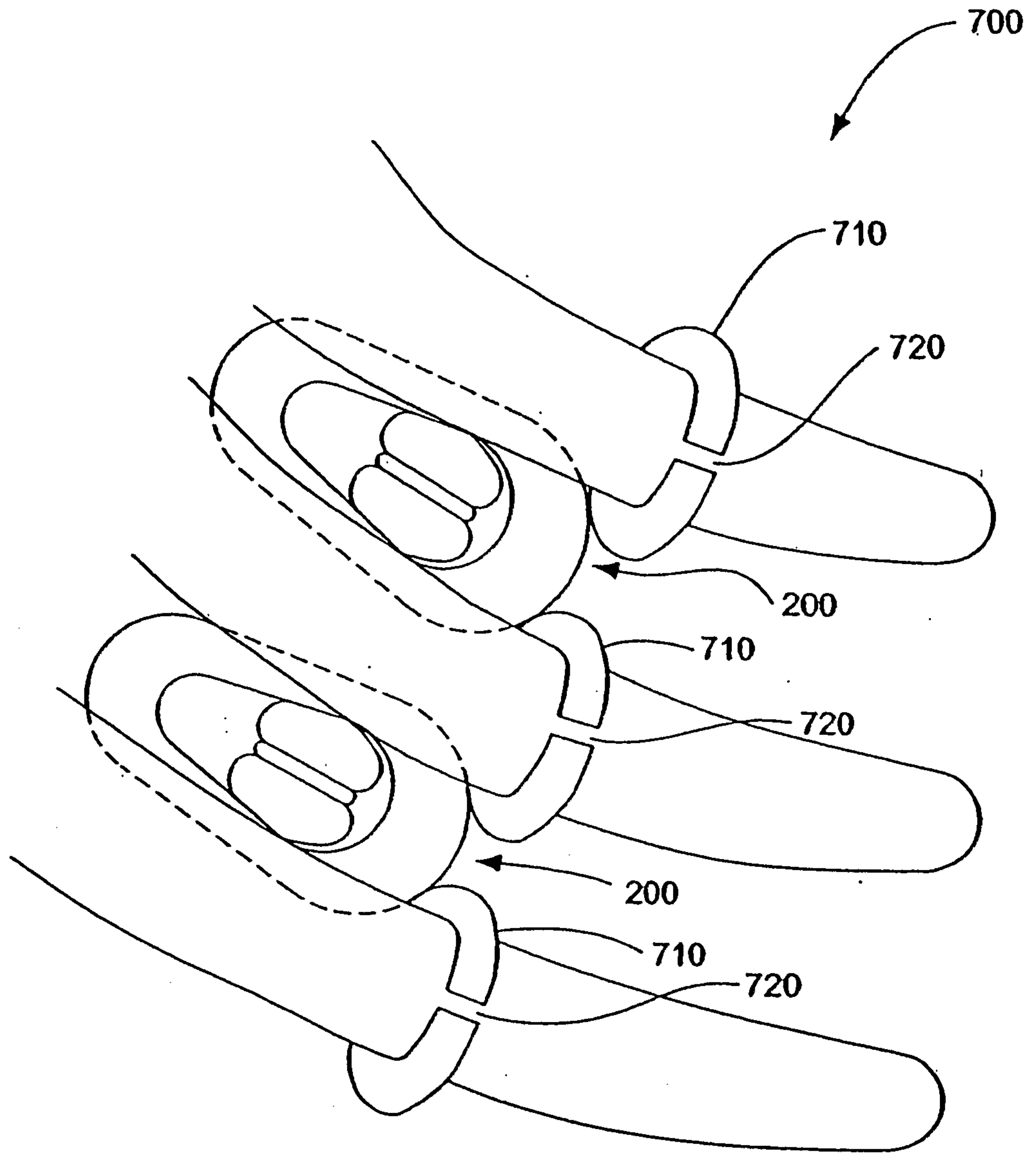

FIG. - 17



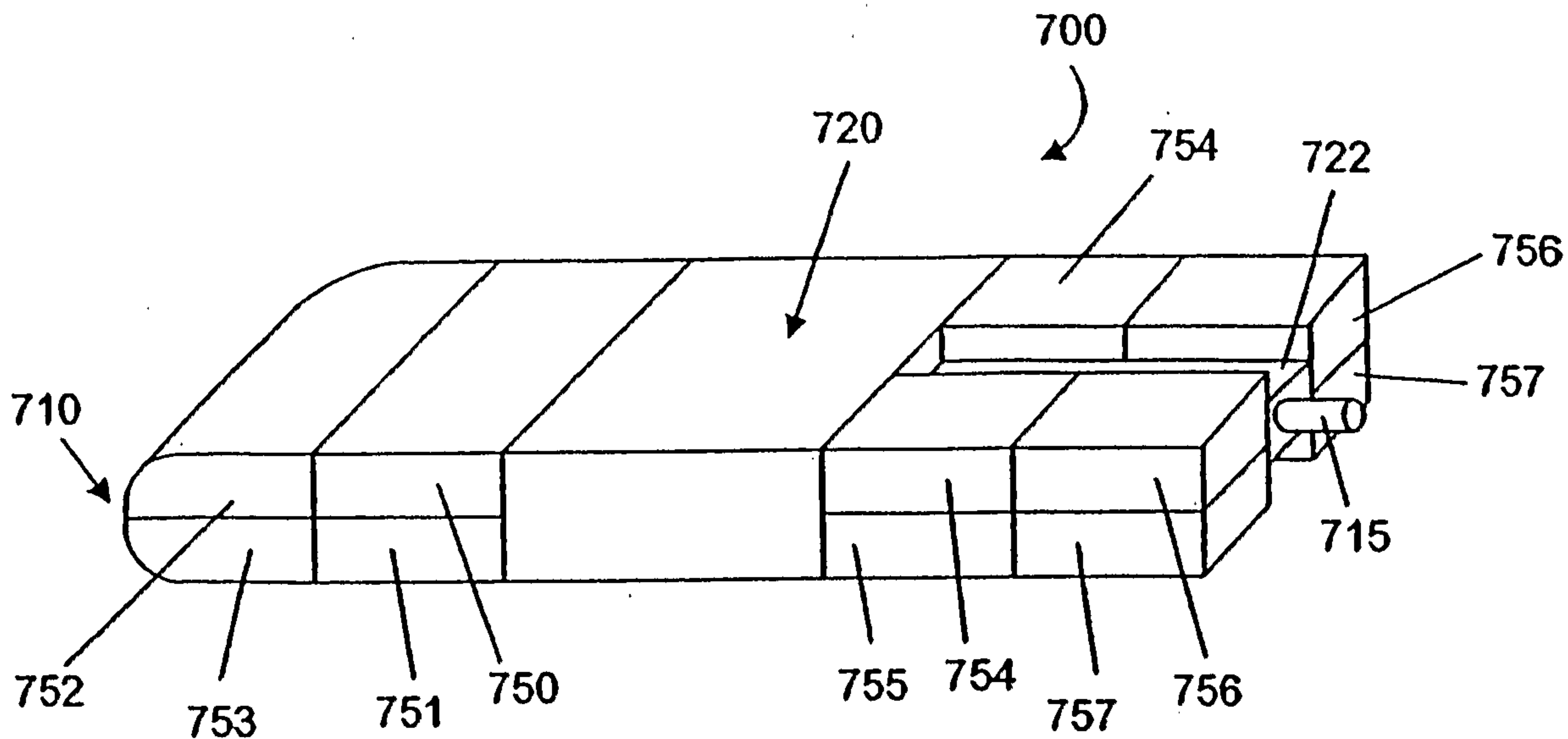

FIG. - 18A

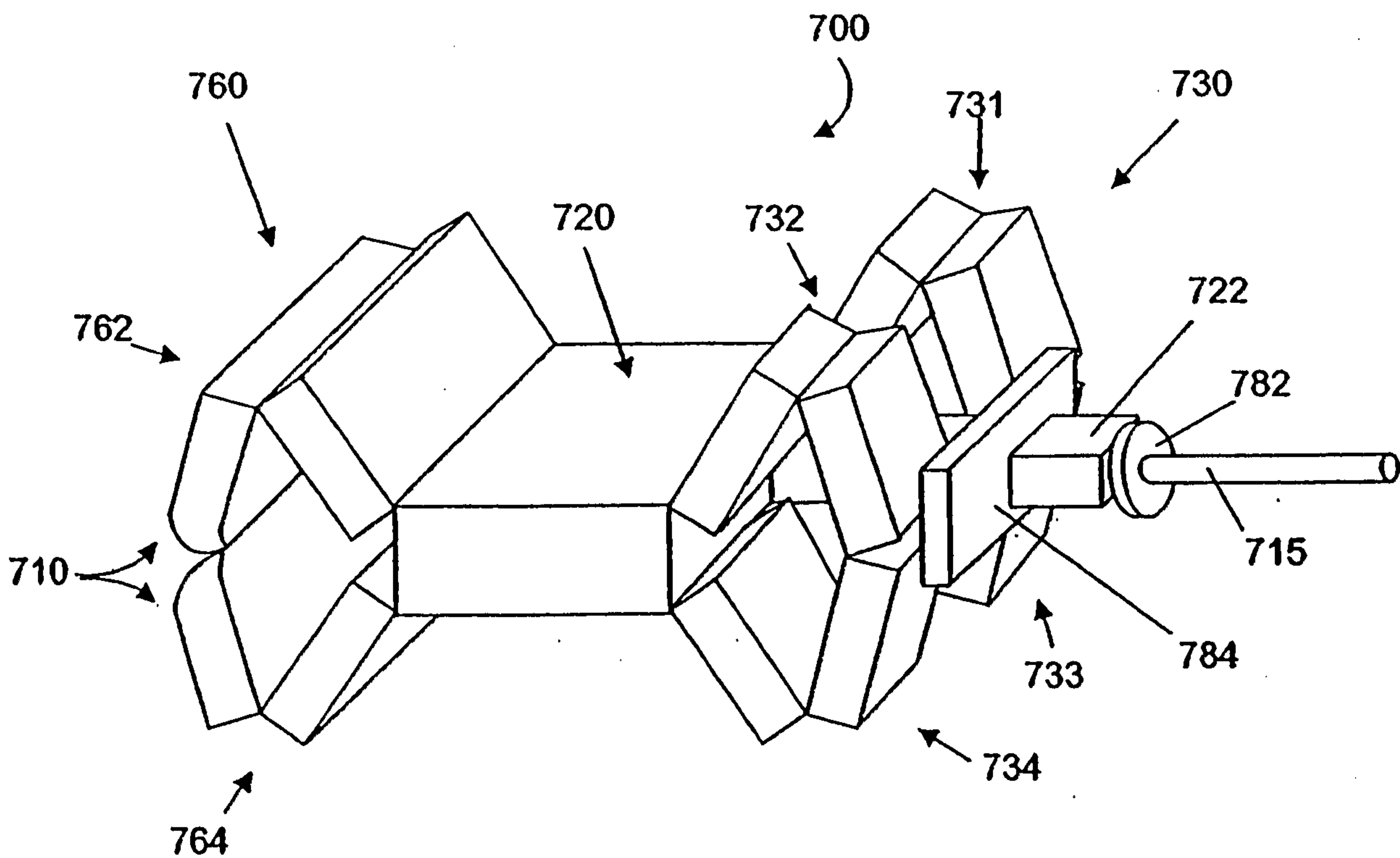

FIG. - 18B

17/26

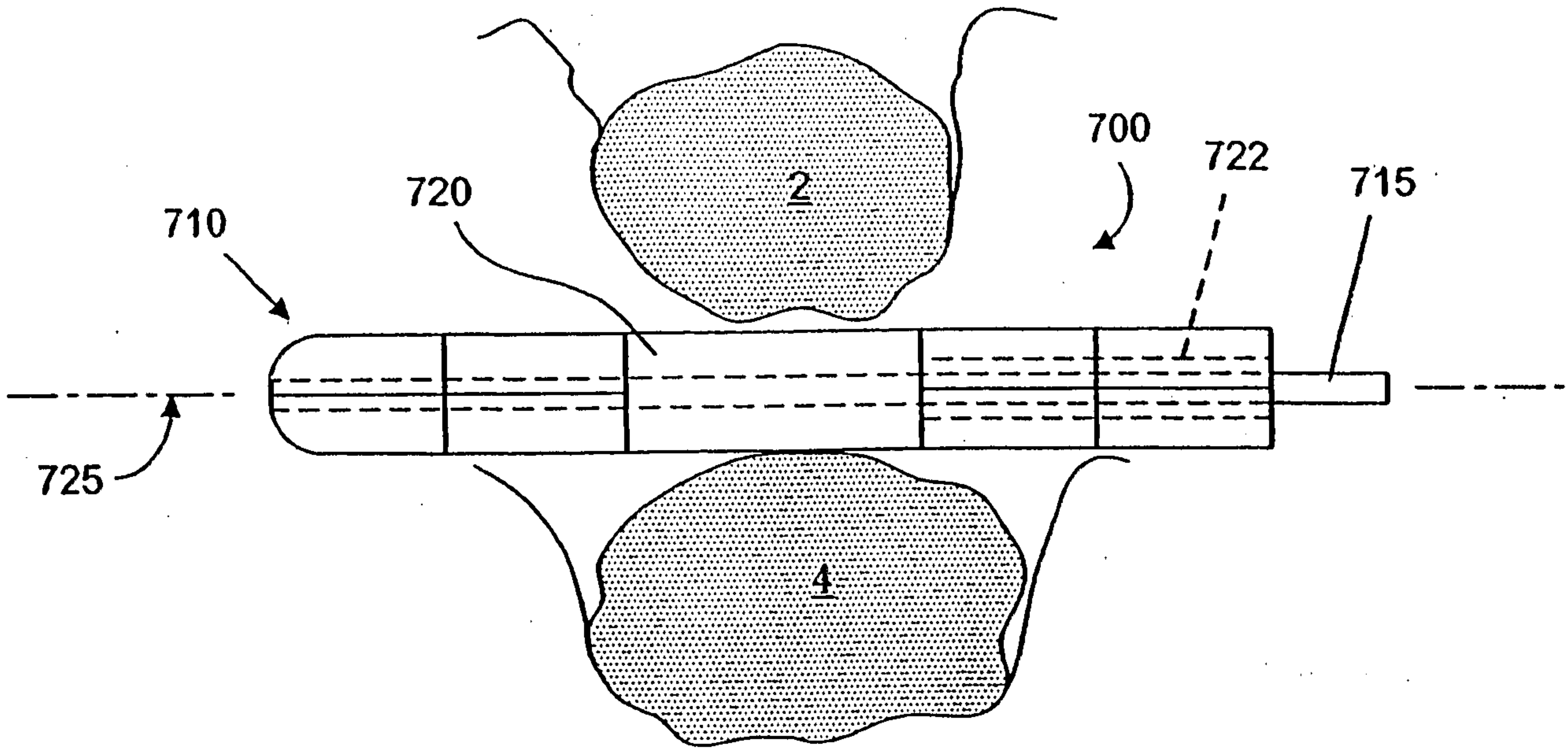

FIG. - 19A

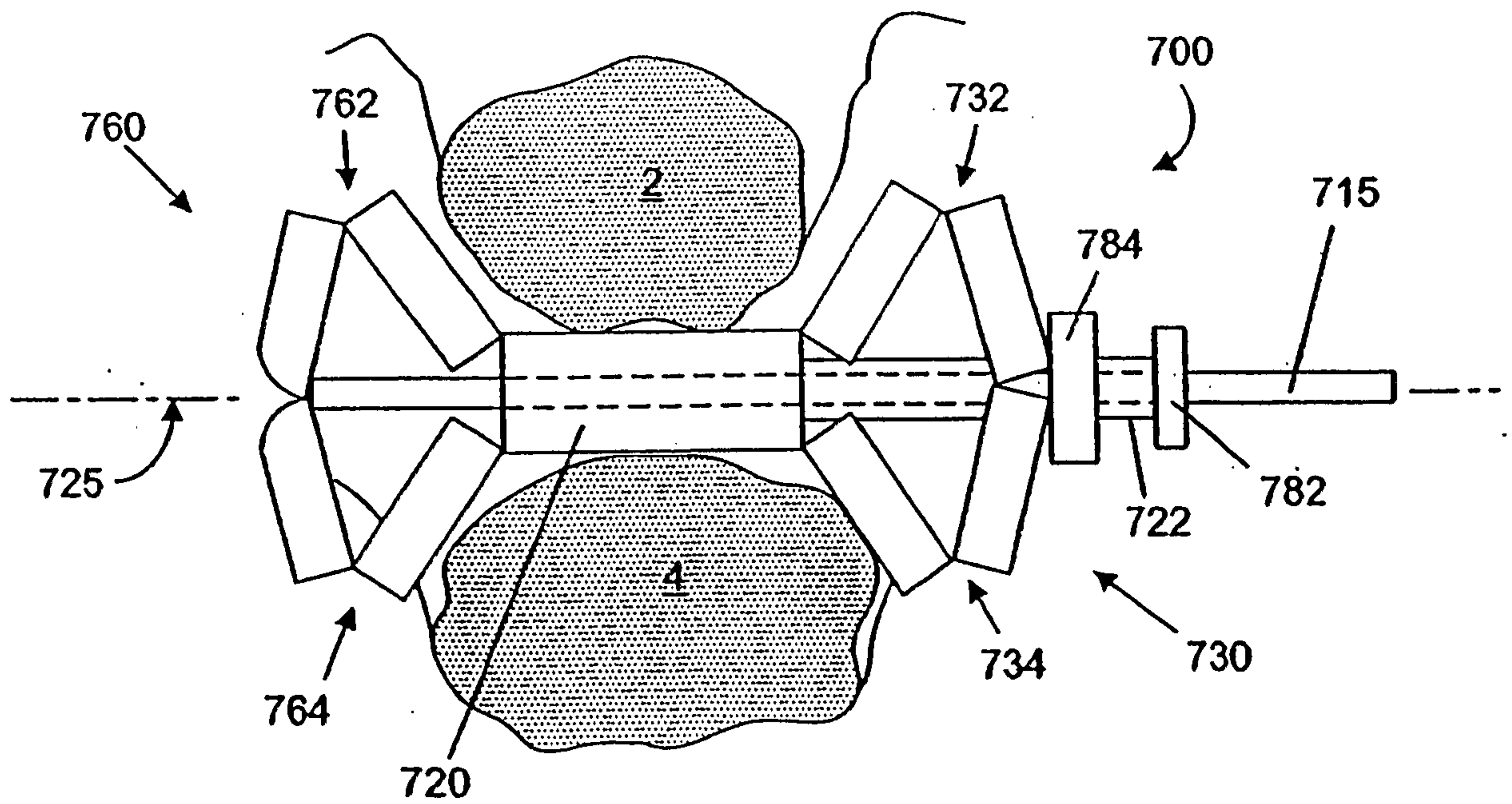

FIG. - 19B

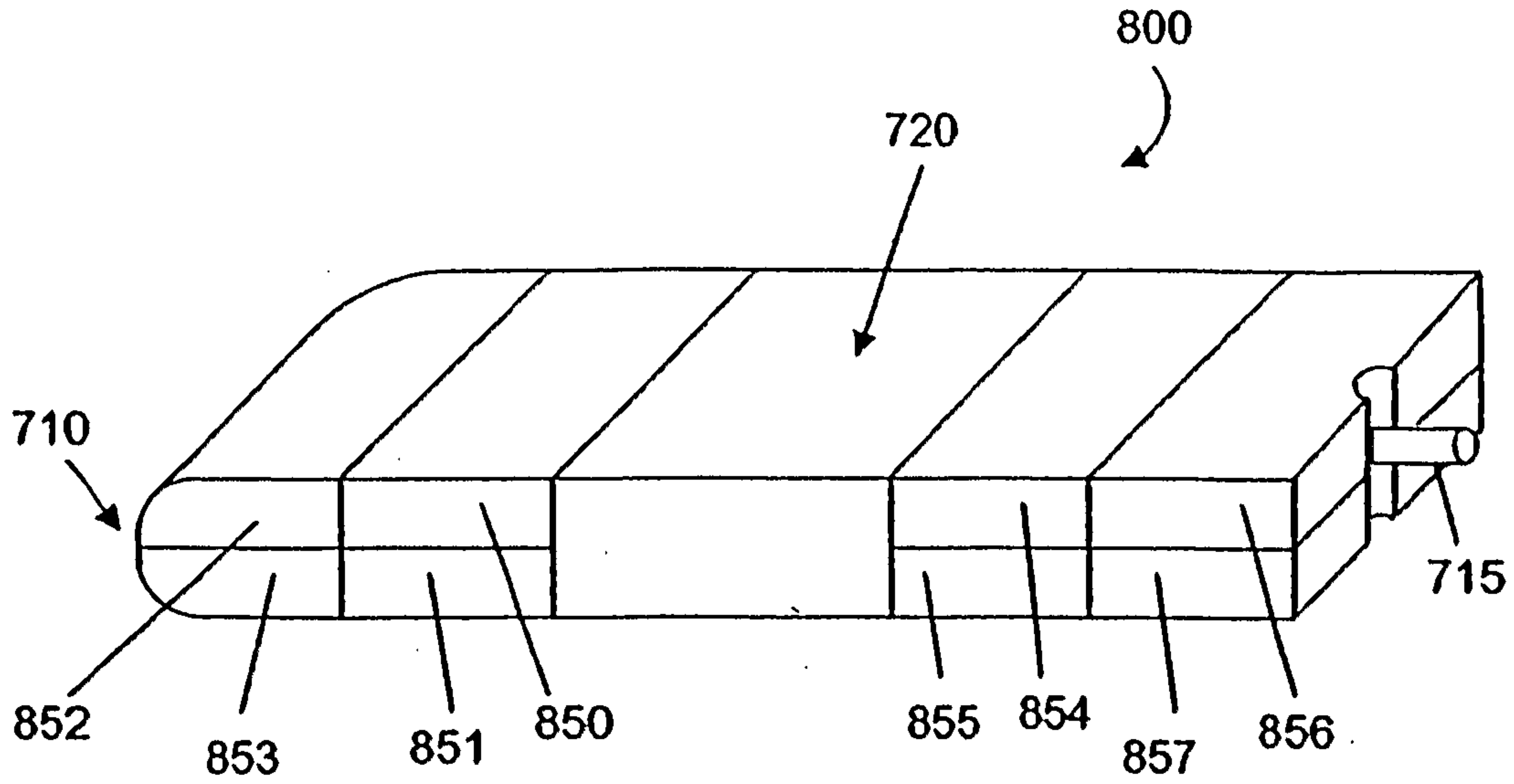

FIG. - 20A

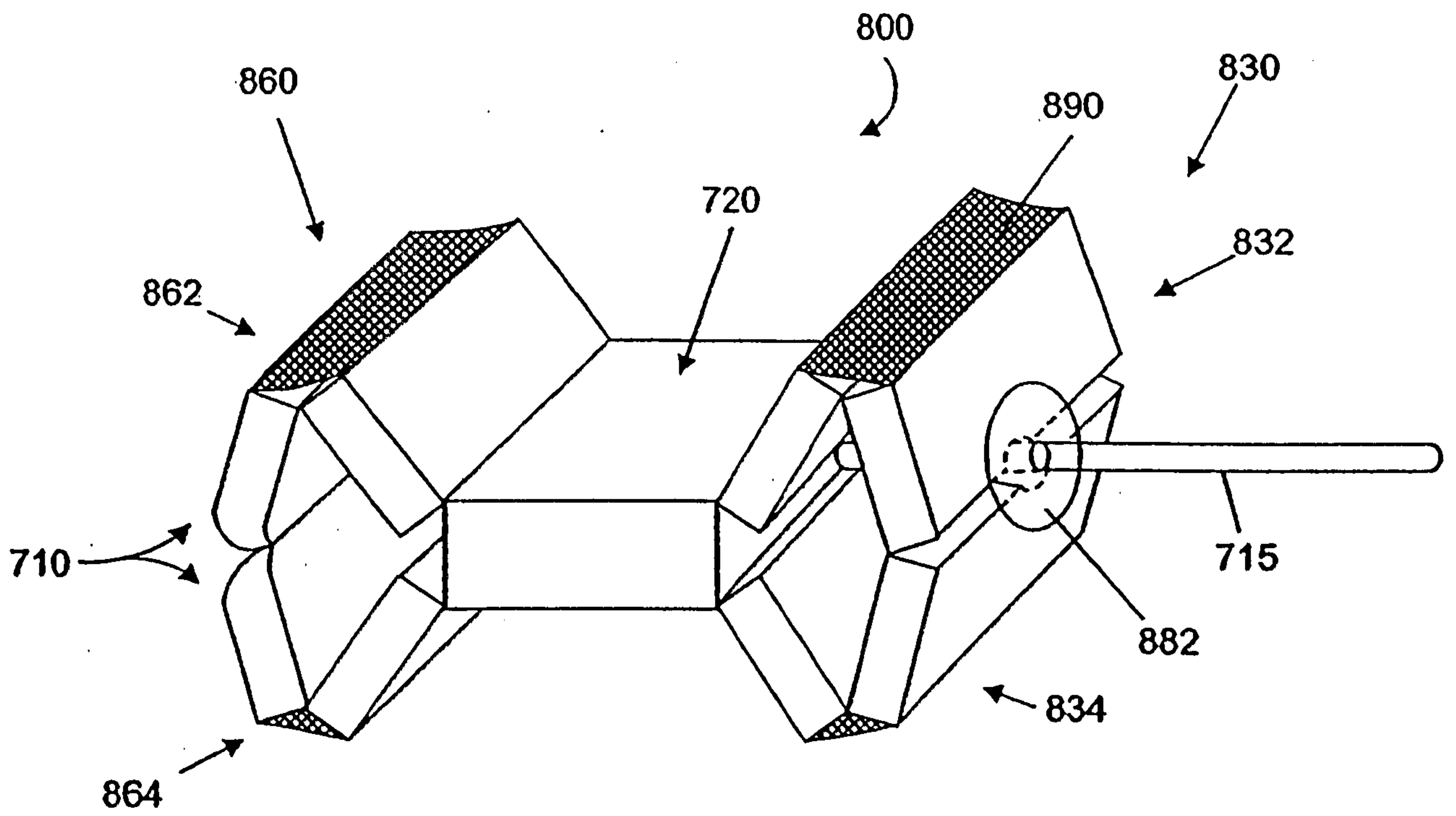

FIG. - 20B



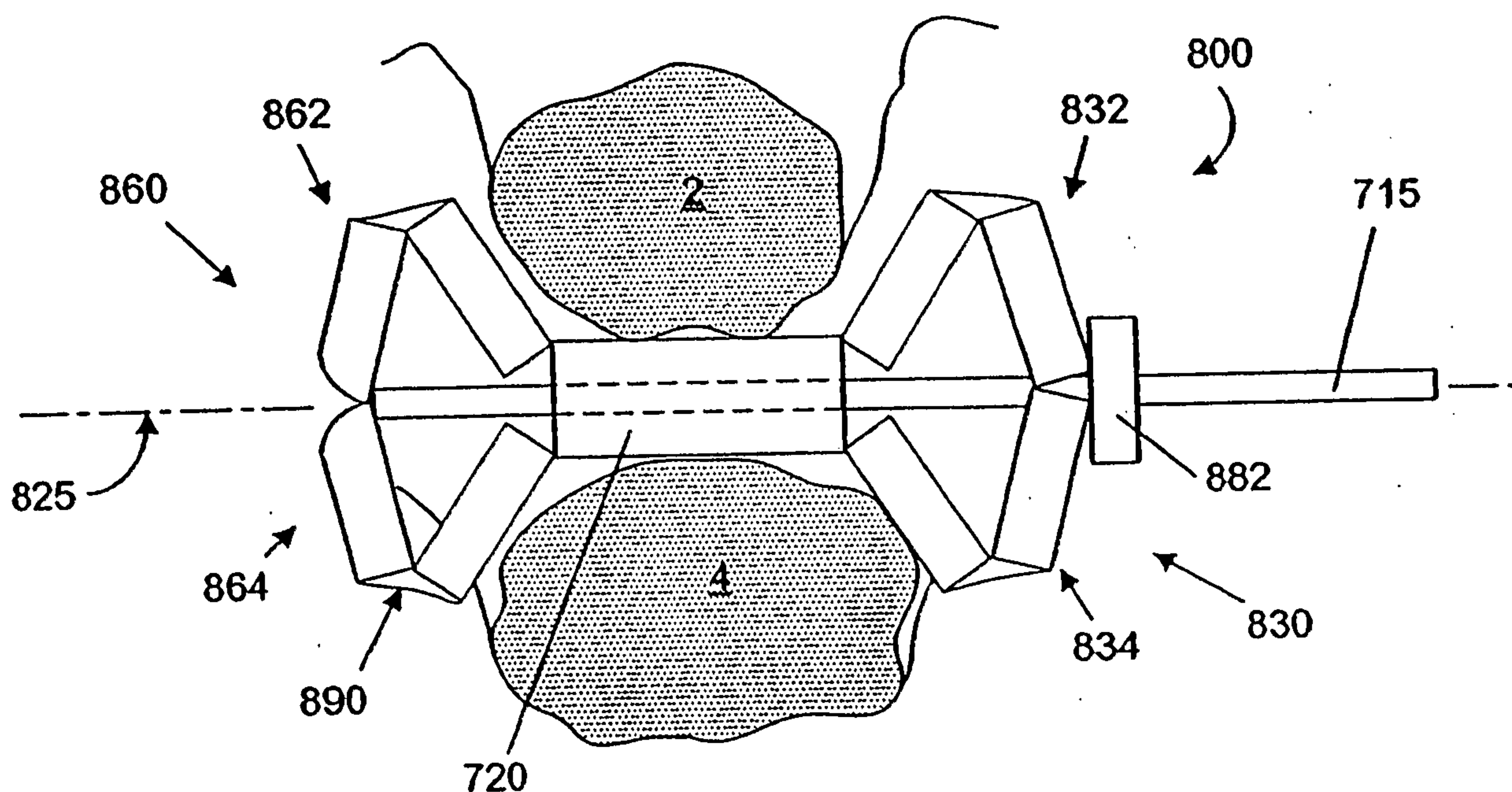

FIG. - 21

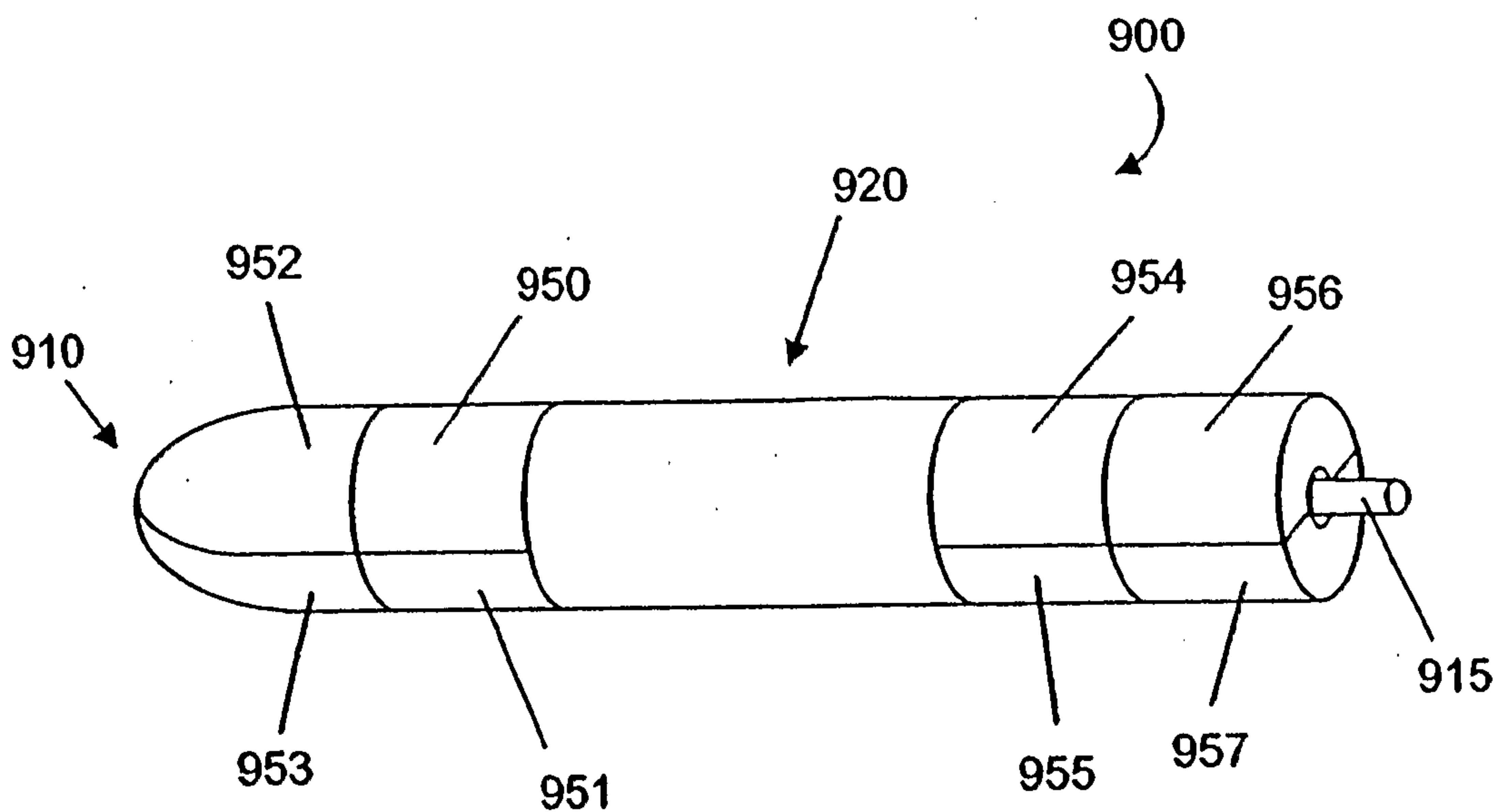

FIG. - 22A

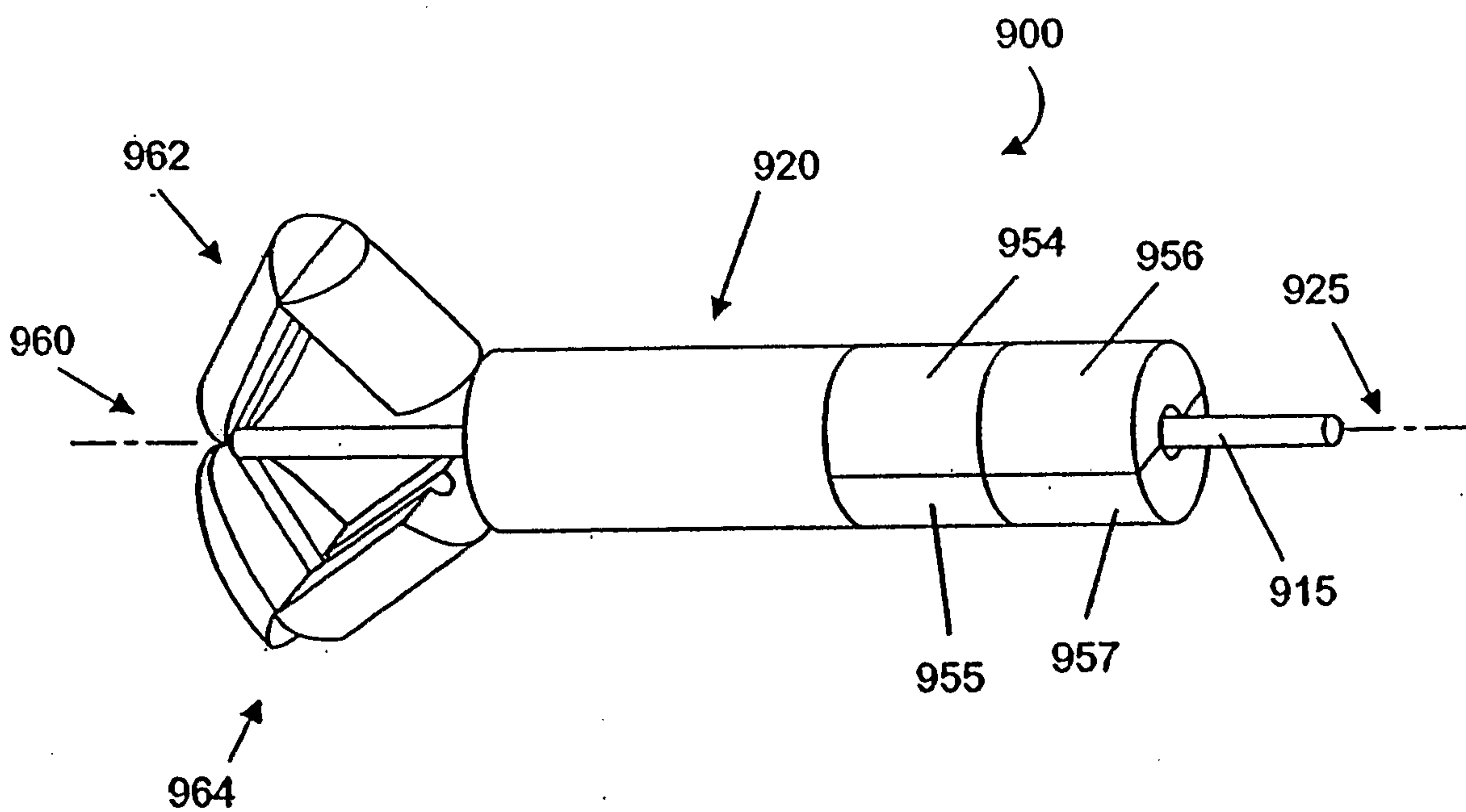

FIG. - 22B

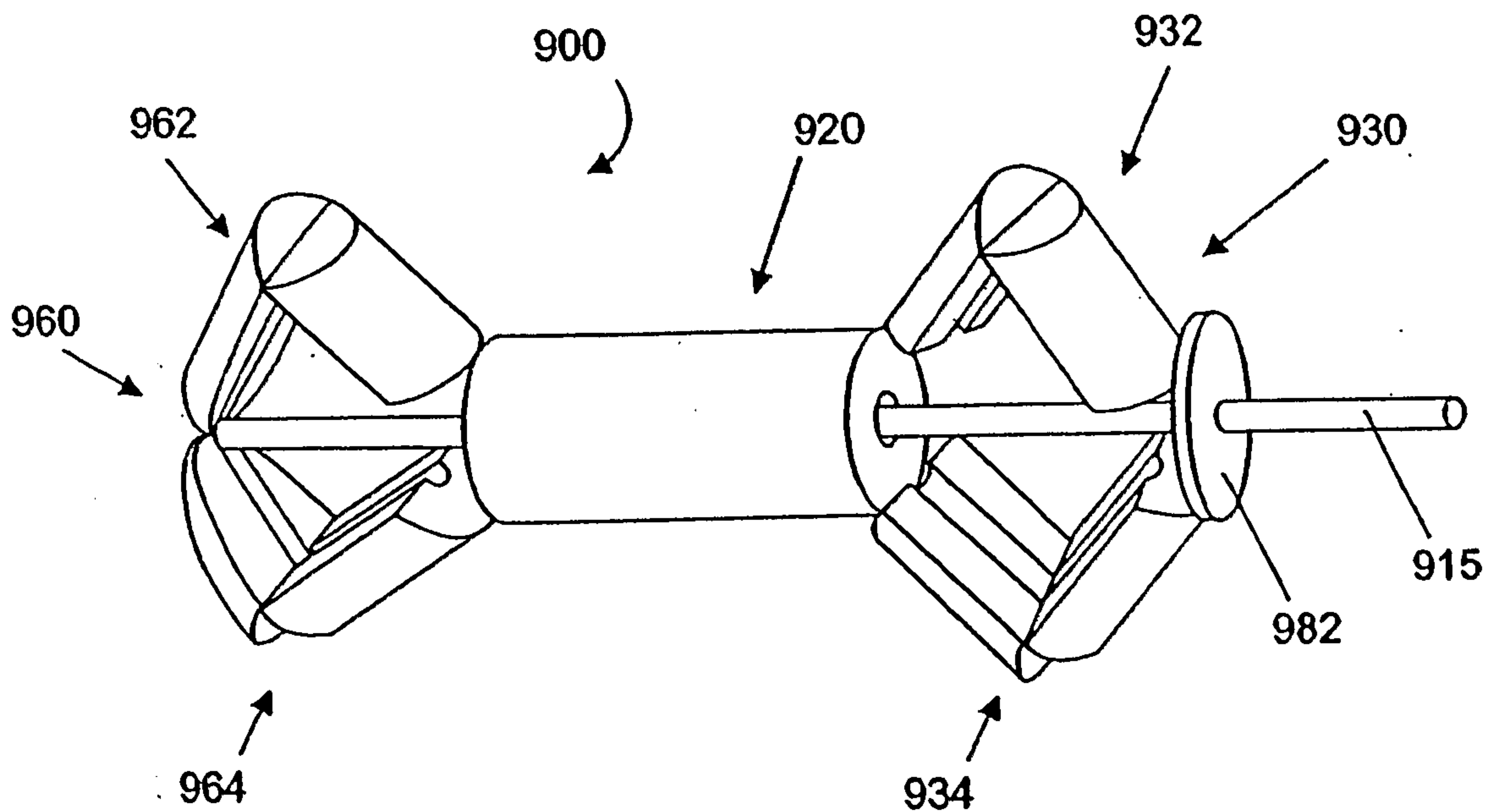
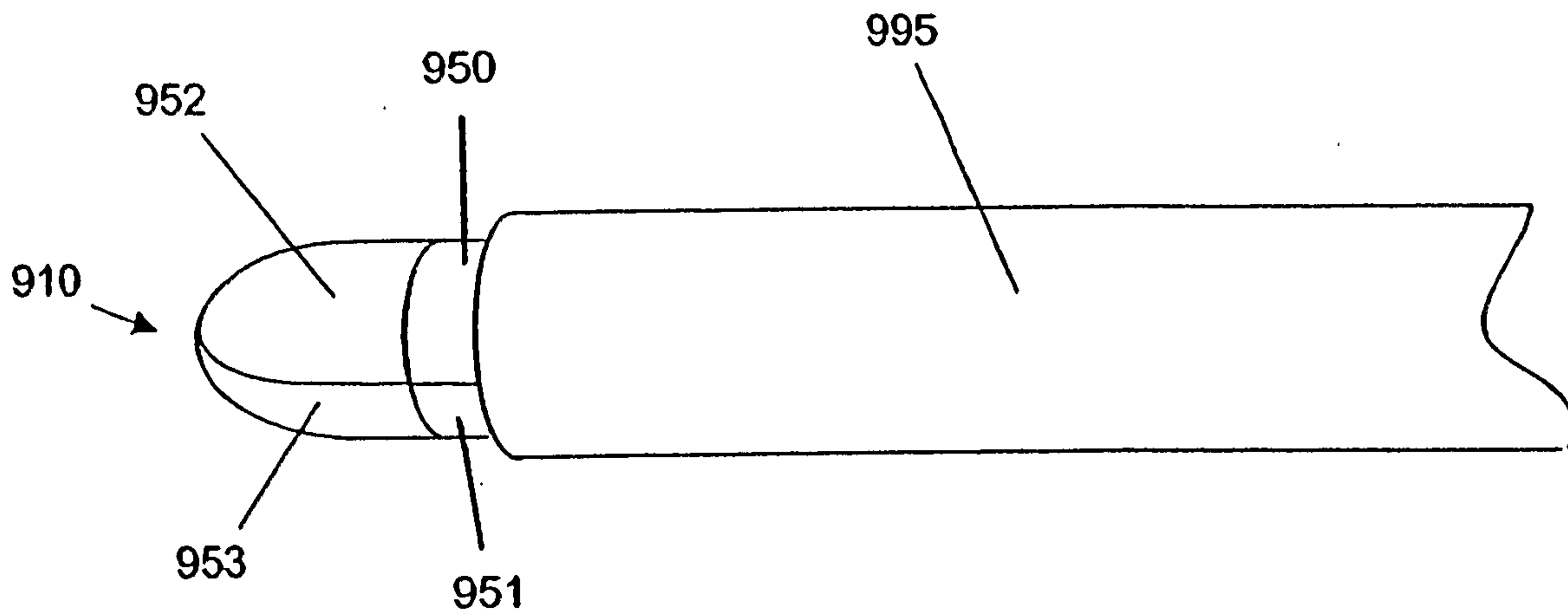
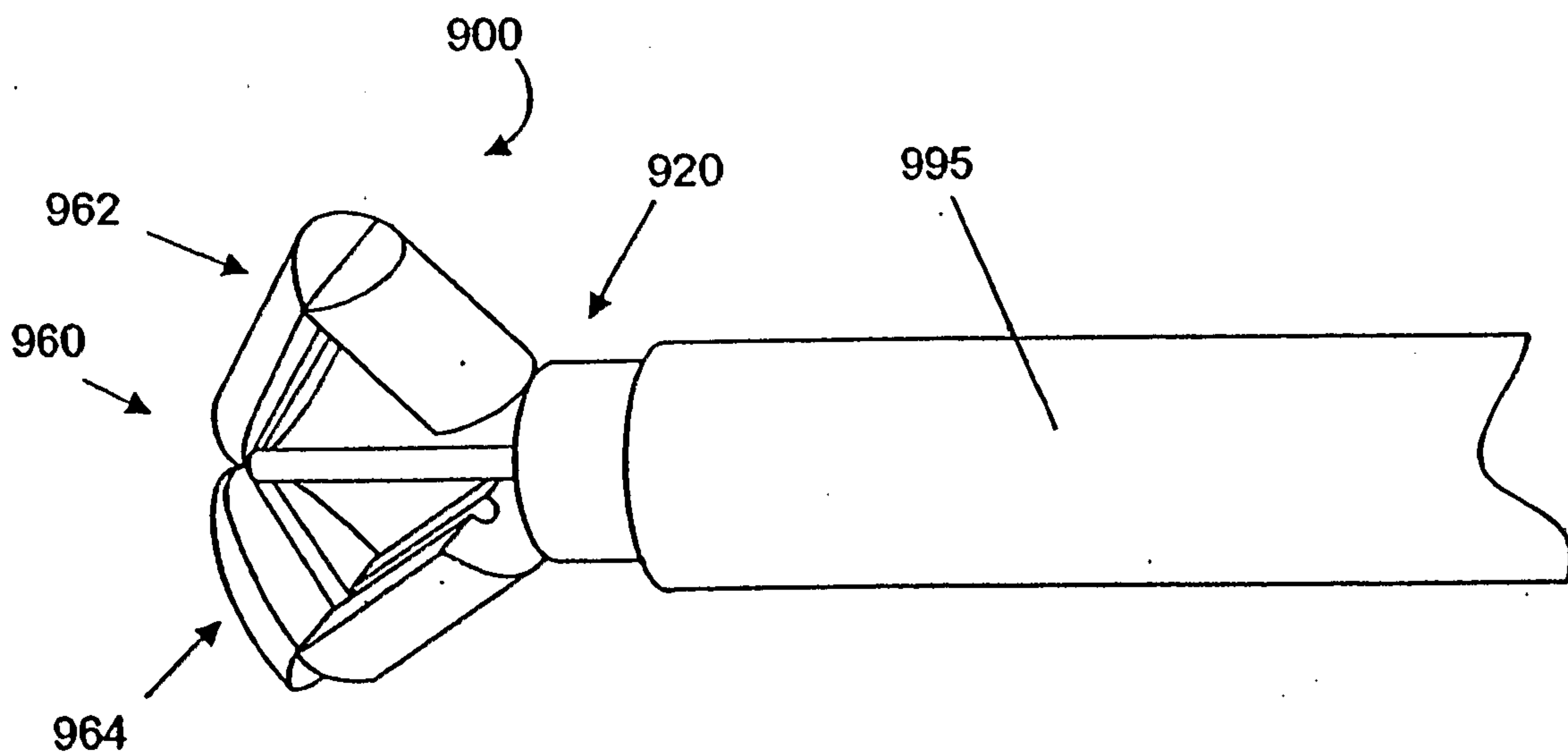

FIG. - 22C





**FIG. - 23A**



**FIG. - 23B**

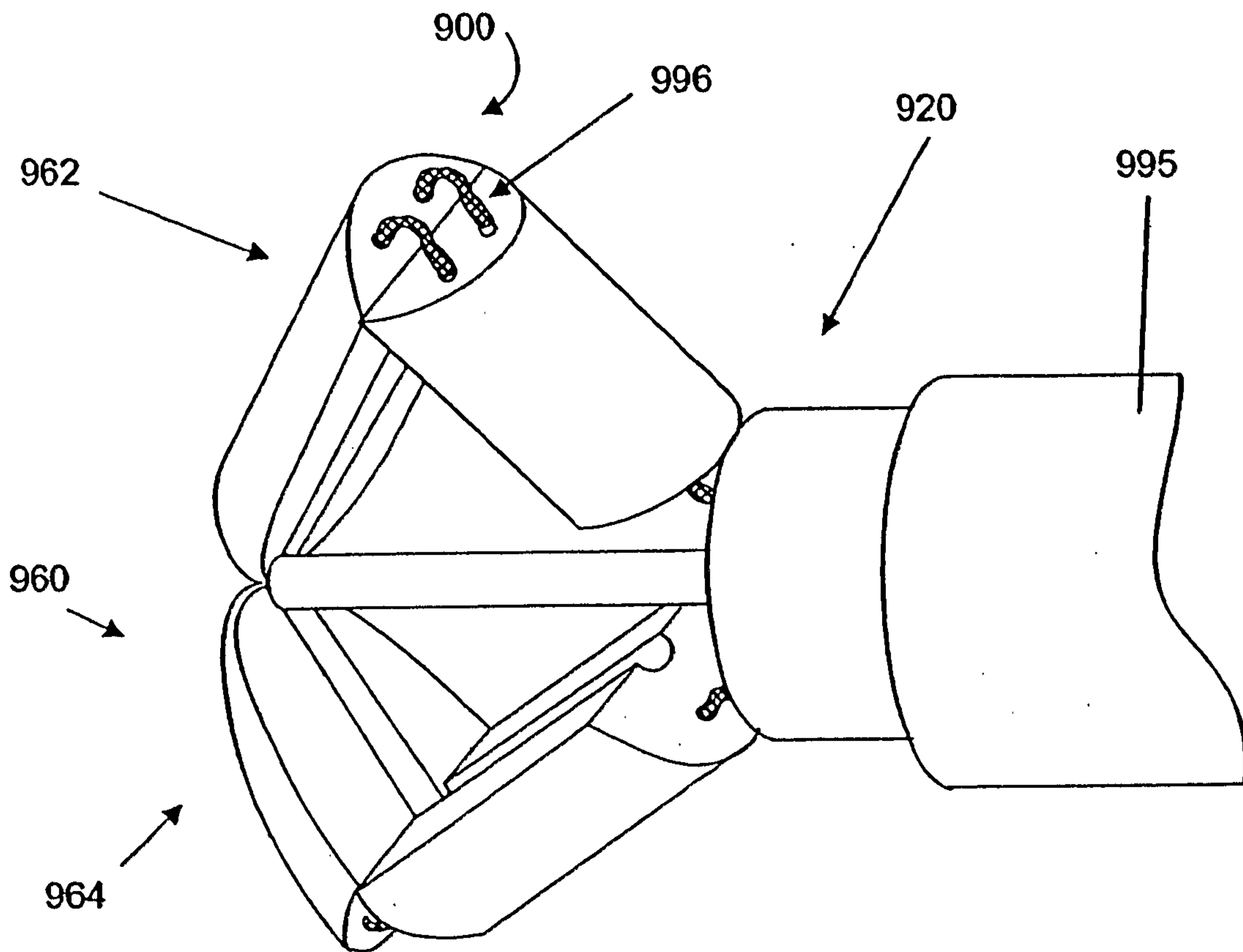

FIG. - 23C

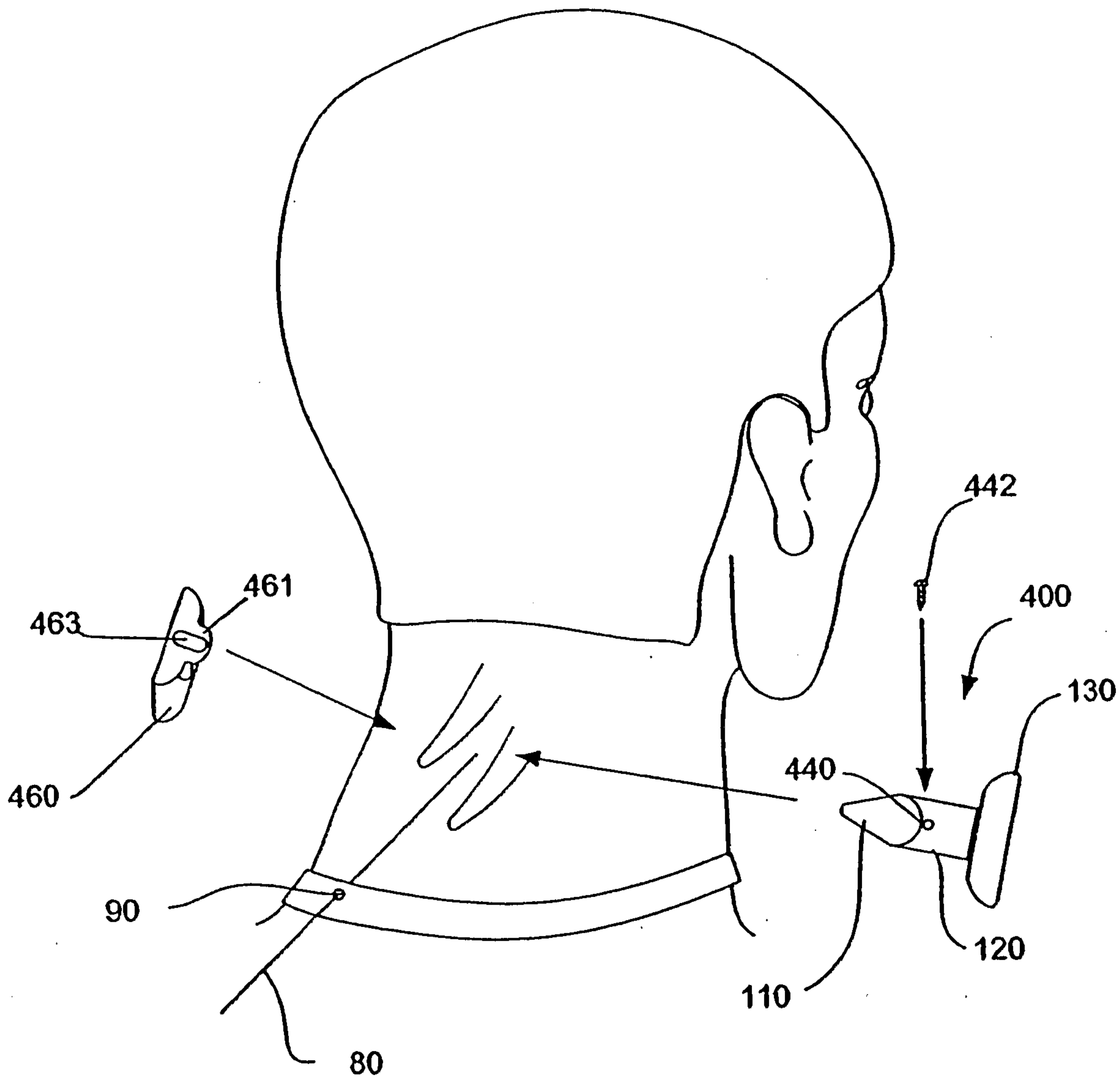

FIG. - 24



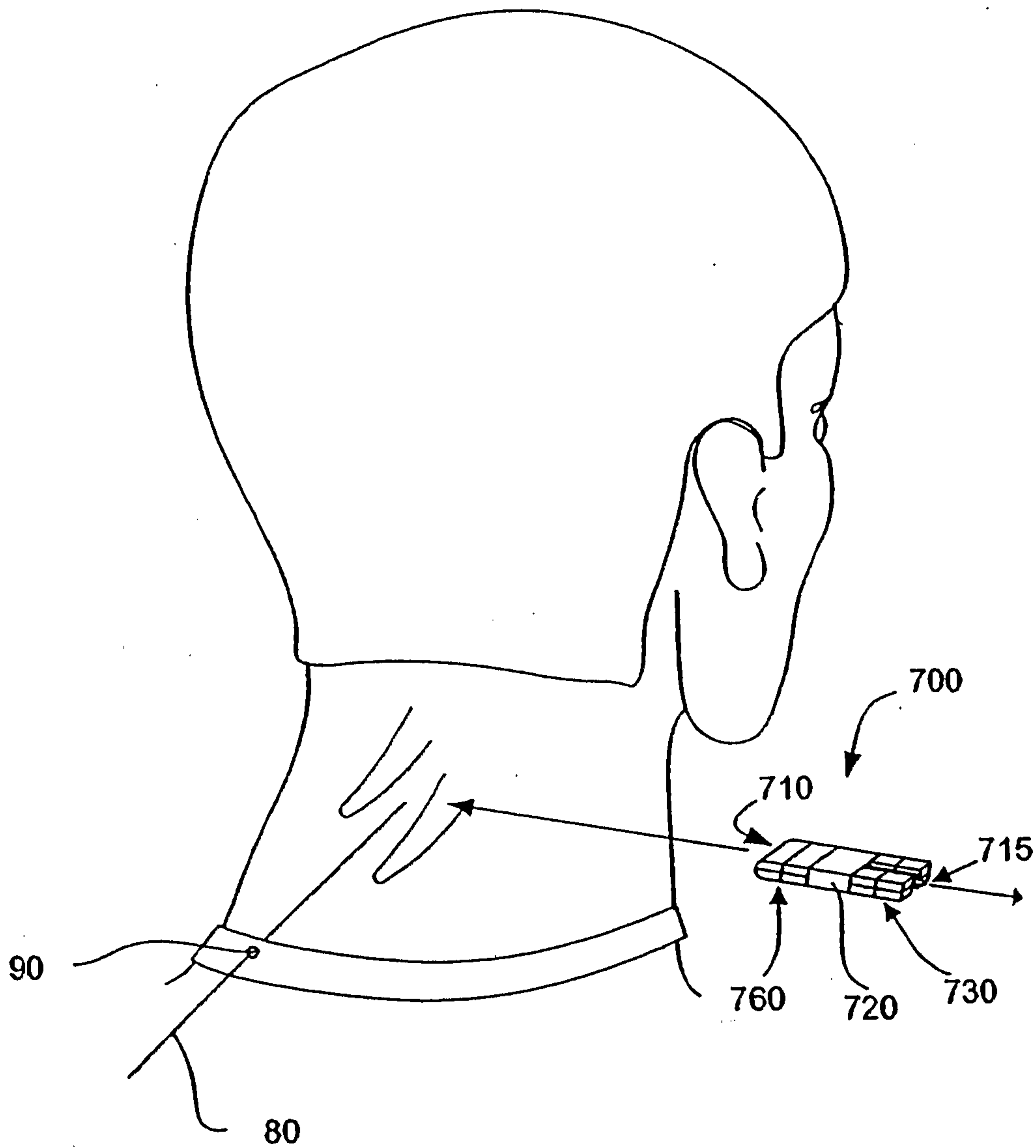

FIG. - 25

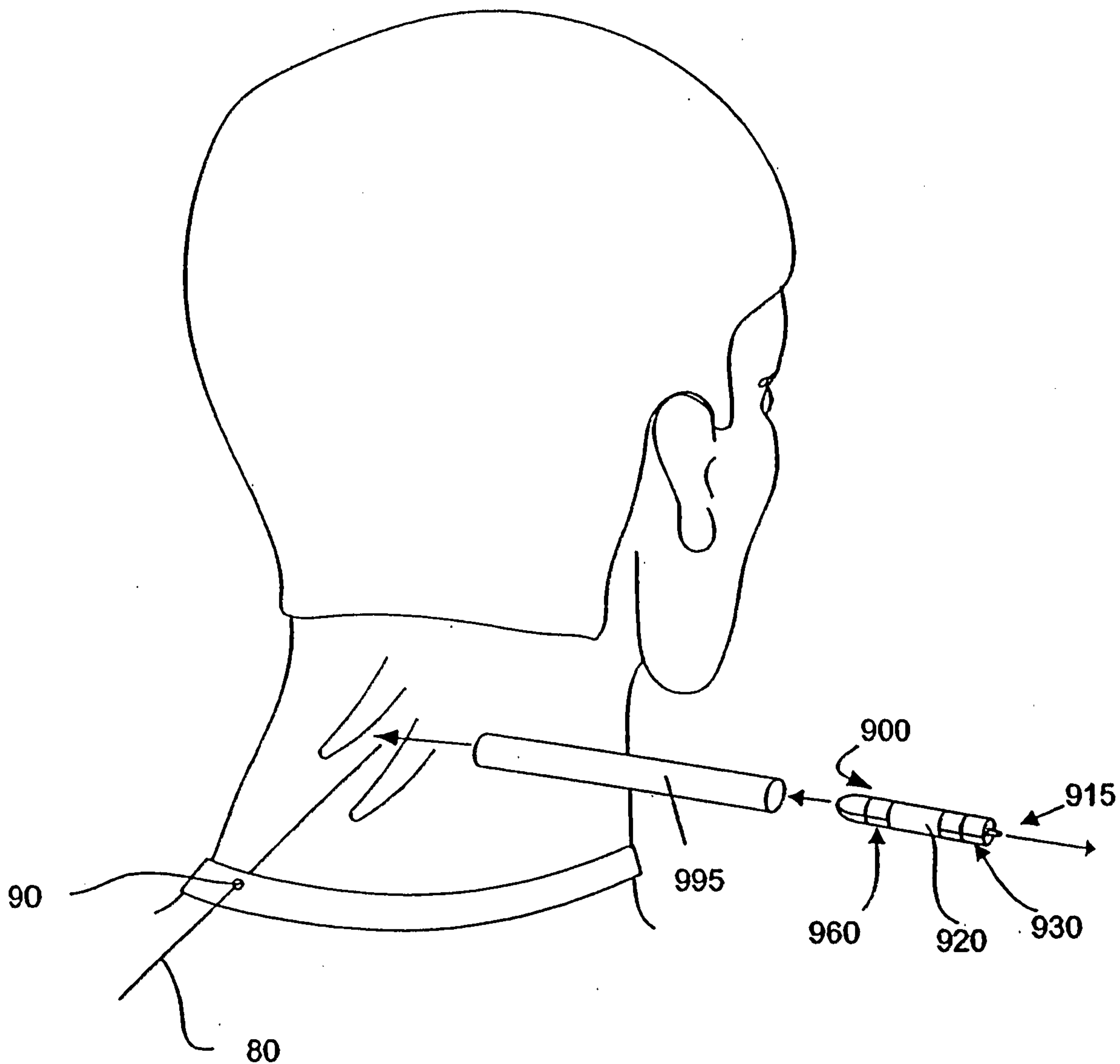

FIG. - 26

