

J. P. HUMASTON.

Improvement in Printing-Telegraphs.

No. 128,627.

Patented July 2, 1872.

Fig. 1.

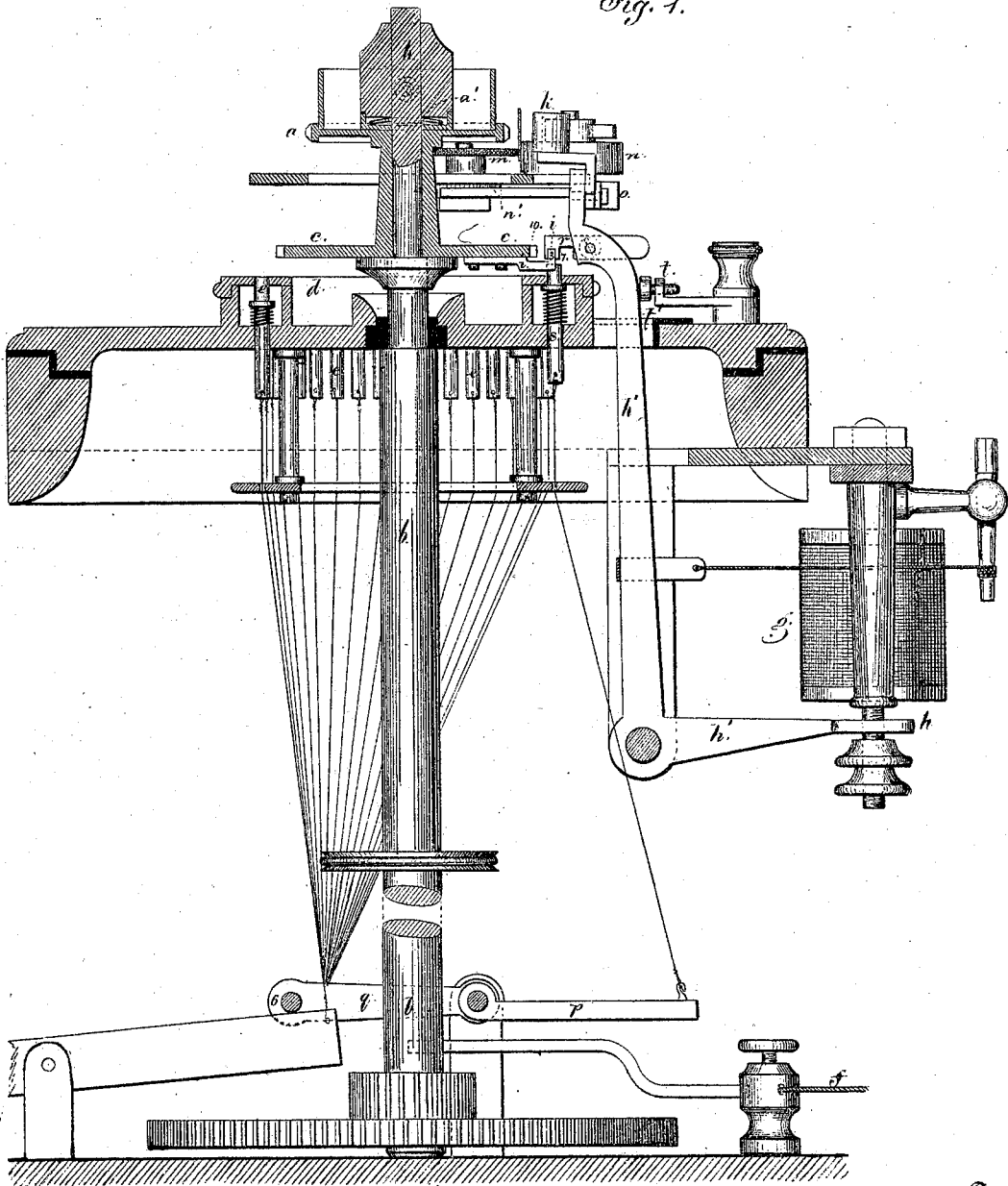

Witnesses  
*Chas. & Smith*  
*Jes. W. Walker*

Inventor  
*J. P. Humaston*  
*Samuel W. Perrell* atty.

J. P. HUMASTON.

Improvement in Printing-Telegraphs.

No. 128,627.

Patented July 2, 1872.

Fig. 2.

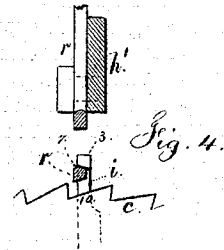
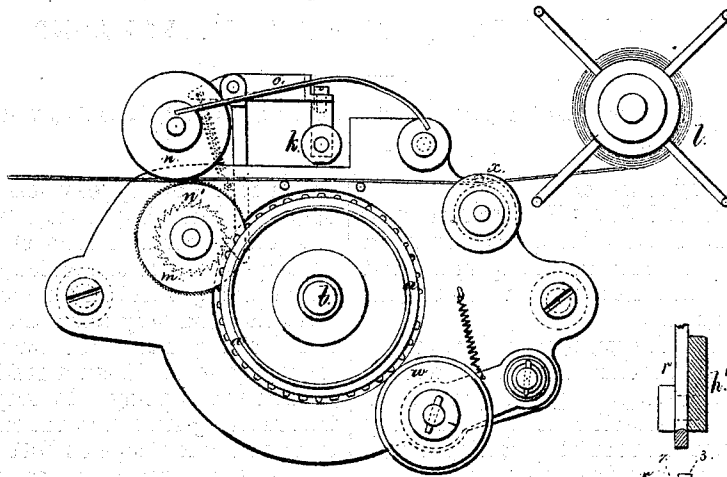
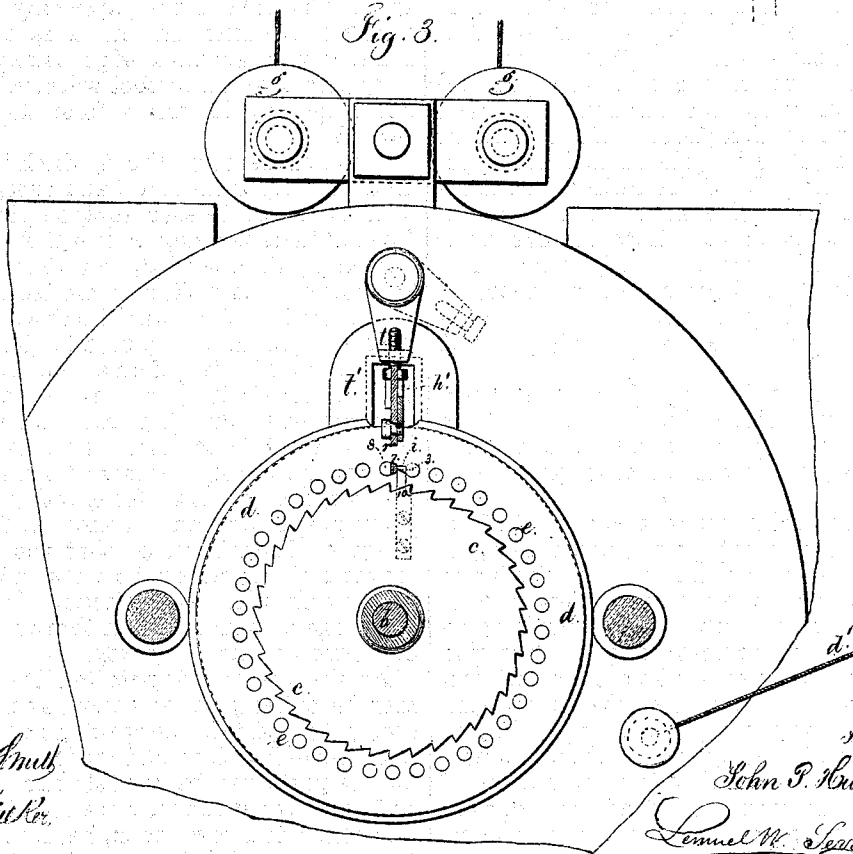

Fig. 3.



Witnesses,  
 Chas. A. Smith,  
 Geo. W. Parker.

Inventor  
 John P. Humaston,  
 Samuel W. Spradley, atty.

# UNITED STATES PATENT OFFICE.

JOHN P. HUMASTON, OF NEW YORK, ASSIGNOR TO EDWARD A. CALAHAN,  
OF BROOKLYN, N. Y.

## IMPROVEMENT IN PRINTING-TELEGRAPHS.

Specification forming part of Letters Patent No. 128,627, dated July 2, 1872.

*To all whom it may concern:*

Be it known that I, JOHN P. HUMASTON, of the city and State of New York, have invented an Improvement in Printing-Telegraphs, and the following is declared to be a correct description of the same.

In this telegraph the type-wheel is revolved by a frictional connection to a motor, until it arrives at a unison-stop. Upon depressing a finger-key the unison-stop is mechanically withdrawn at the transmitting-station and a circuit broken, so that the unison at the receiving-instrument is withdrawn; thereby both type-wheels start and rotate together. The type-wheel at the transmitting-station is stopped by the finger-key mechanism, that also is a circuit-closer that throws the electric current through the magnet of the receiving instrument, the armature of which moves the impression-pad and also the unison so that the letter is printed and the type-wheel also stopped. On releasing the finger-key the wheels revolve around to the unison-point and stop, or else they revolve until stopped by the depression of another key. By this means the keys can be manipulated with great rapidity, because the unison-stop is only operative when a finger-key is not depressed.

In the drawing, Figure 1, is a vertical section of the machine. Fig. 2 is a plan of the type-wheel and printing mechanism; and Fig. 3 is a plan of the circuit-closing mechanism.

The type-wheel *a* is upon a vertical shaft, *b*, driven by competent power, there being a friction-clutch at *a'* that allows the shaft *b* to continue its motion when the type-wheel *a* is stopped. A ratchet-wheel, *c*, is connected to the type-wheel *a* by a sleeve, so as to move with it, and a stop, *i*, projecting from this wheel, corresponds with the blank of the type-wheel. Around the insulated ring *d* is a circular range of circuit-closing pins, *e*, that, in a normal position, are drawn below the surface of *d*. Each pin is connected with its appropriate key in the range of keys by any convenient mechanism. I have shown springs to project the bolts, and cords connected with the keys to draw them down, so that when a key is struck its pin will rise up from the ring *d* and stop

the arm *i* and type-wheel with the corresponding letter in position for printing.

The line-wire *d'* is connected with *d*, and the battery-wire *f* is connected with the shaft *b*. These being insulated from each other the pulsation can only reach the line through the arm *i* and pin *e*. This pulsation acts in the magnet *g* at the distant station, either direct or through a relay. It may also act at the transmitting-station in the same magnet, so as to print the message at both ends of the line. The electro-magnet *g* has an armature, *h*, and lever *h'*, carrying the printing-pad *k*, that forces the paper (from the reel *l*) against the type. The feed of the paper may be effected in any convenient manner. I have shown the roller *m* with serrated edge, the spring holding-roller *n*, and a ratchet-wheel, *n'*, and pawl acted upon by the arm *o* from the printing-lever *h'*.

Upon reference to Fig. 4, which is a plan in enlarged size of the stop *i* and parts operating with it, it will be seen that on the printing-lever *h'* there is a dog, *r*, and that on the arm *i* is an inclined stud, *s*, and that the end of the dog *r* forms a stop to the teeth of *e*, and that there is a downward inclined projection, *7*, on *r*, adjacent to the stud *s*. The pin *s*, in the range of pins, forms the unison-bolt. This unison-bolt *s*, in the normal position, is elevated so that the arm *i* cannot pass it, but the same is connected so that it is withdrawn by depressing either of the finger-keys. The mechanism shown for effecting this is the lever *p*, rocking-frame *q*, and bar *6*, over the range of finger-keys, so that the lever *p* is moved and the unison-bolt *s* withdrawn simultaneously with the projection of the pin, of the range of pins *e*, that is thrown up by the depression of the given key.

At the transmitting-station the magnet *g* may be entirely out of action, and the stop *t* swung around into the position shown by dotted lines in Fig. 3, so that the impression-lever and its parts may be entirely out of the way, and the lever *h'* cannot close the circuit when this stop *t* is thrown back, because the plate *t'* is of non-conducting material, or insulated.

The transmitting is mechanical. Suppose the arm *i* to be stopped by the unison-bolt, the circuit to the distant station being completed

through the same, upon striking a finger-key this unison-bolt is withdrawn, the circuit broken, the type-wheels revolve by synchronous movements until the type-wheel at the transmitting-station is arrested by the pin in the range *e*, that has been simultaneously elevated upon striking the finger-key. This contact closes the circuit to the distant station, and the circuit remains closed, and both type-wheels stopped until the finger-key is released, whether that be a longer or shorter period. A second finger-key may be depressed before the first is liberated, in which case the unison-bolt is still held down, and upon liberating the first key the circuit through its pin is broken, and the type-wheels are simultaneously revolved until the arm *i* comes in contact with the pin of the range that has been elevated by the second key, and the circuit is again closed and the type-wheels stopped, and so on; or, if the finger-keys are unacted upon, the arm *i* comes into contact with the unison-pin *s* and stops, and the circuit remains closed until another key is operated.

At the receiving-station the unison-bolt has to be withdrawn by any suitable mechanism, as the dog *r*, being under the control of the magnet *g*, forms the unison-stop. The electric circuit being closed at the transmitting-station through the unison-bolt *s*, the end of the dog *r* at the receiving-station rests against the tooth 10 of the wheel *c*, and prevents the type-wheel rotating. The moment the circuit is broken and the magnetic energy ceases the dog *r* falls back and the type-wheel revolves. When the circuit is again closed at the transmitting-station the magnet *g* brings up the printing-lever at the receiving-station, giving the impression and simultaneously holding the type-wheel by the dog *r* against the corresponding tooth of the wheel *c*. This operation will take place whenever the circuit is closed, and in arresting the type-wheel at unison, the stud 3 of the arm *i* at the receiving-station comes into contact with the projection 7 on *r* and arrests the movement slightly before the arm *i* at the transmitting-station arrives at the unison-bolt *s*; hence, when the circuit is closed by the last-named contact, the dog *r* is moved by the magnet releasing 3 and 7, and holding the type-wheel by the end of the dog against the tooth 10, as before.

By a unison-key acting only to withdraw the bolt *s* and break the circuit long enough for the type-wheel at the transmitter to make more than one revolution, all the machines in the electric circuit will be stopped by the contact of 3 and 7, and resume their normal and unison-position as the circuit is again closed through *s*.

The connections to bring in a relay when used at either the transmitting or receiving station are of the usual character. The inking-roller *w* and paper guide *x* are of usual character.

Any number of instruments in an electric circuit can be operated simultaneously; only one wire is required; and unison is instantly obtained in all the instruments should any get out of time.

If at any one of the receiving-instruments in the line the attendant notices that the spelling is wrong he can bring his and all other instruments in the line into unison by breaking the circuit by a switch or otherwise for a short period—say one or two seconds—and the operator at the transmitting-station learning by his magnet or a sounder that the line is inoperative, repeats whatever may be necessary.

I claim as my invention—

1. A type-wheel revolved by a frictional clutch and a stop, *i*, arrested and detained while the key is depressed, substantially as set forth.
2. A type-wheel revolved by friction and a stop, in combination with a circular range of pins, controlled by keys that stop the type-wheel of the transmitting-instrument, and also close or break the electric circuit to the distant instrument, substantially as set forth.
3. A unison-bolt to arrest the movement of the type-wheel and control the electric circuit, in combination with a range of finger-keys that act upon the said unison-stop as well as the type-wheel stops, substantially as set forth.
4. The type-wheel *a* and wheel *c*, in combination with an electro-magnet printing lever and dog, that simultaneously give the impression and hold the type-wheel until released by the electro-magnet, substantially as set forth.
5. The unison-bolt, in combination with a range of finger-keys and stops to arrest the movement of the type-wheel, substantially as set forth, so that the unison-bolt is removed by either finger-key simultaneously with the movement by that key of its type-wheel stop, substantially as set forth.
6. A series of keys and a circular range of stop-pins connected by cords, in combination with the type-wheel and impression mechanism, substantially as set forth.
7. A printing-lever provided with a stop that arrests and holds the type-wheel, substantially as set forth.
8. A printing-lever provided with an impression-pad, a stop for the type-wheel, and a connection to the feeding mechanism, substantially as set forth, in combination with one electro-magnet for operating said parts, substantially as set forth.
9. The printing-pad, the type-wheel stop, and the unison device, actuated by one electro-magnet, substantially as set forth.

Signed by me this 22d day of April, A. D. 1872.

Witnesses: J. P. HUMASTON.  
GEO. T. PINCKNEY,  
HAROLD SERRELL.