

12 **EUROPEAN PATENT APPLICATION**

21 Application number: **89311112.0**

51 Int. Cl.<sup>5</sup>: **B65D 71/42**

22 Date of filing: **27.10.89**

30 Priority: **28.10.88 GB 8825328**

71 Applicant: **THE MEAD CORPORATION**  
**2000 Courthouse Plaza NE**  
**Dayton Ohio 45463(US)**

43 Date of publication of application:  
**16.05.90 Bulletin 90/20**

72 Inventor: **Martin, Claude**  
**150 Rue des Eglantines**  
**Brassioux Deols 36130(FR)**

64 Designated Contracting States:  
**BE DE ES FR GB IT NL**

74 Representative: **Hepworth, John Malcolm**  
**Hepworth Lawrence & Bryer 36 Regent Place**  
**Rugby Warwickshire CV21 2PN(GB)**

54 **Multipacks for flanged containers.**

57 A package incorporating a group of containers (C) having top flanges (f) is formed from a paper-board blank (10) having side panels (22, 26) which flank the exposed sides of the containers. The side panels each have a part (30, 34) attached to the side of an adjacent container, the attached part being frangibly connected (32, 36) to the remaining part of said side panel so that the remaining part can be detached leaving the attached part secured to the container side wall.

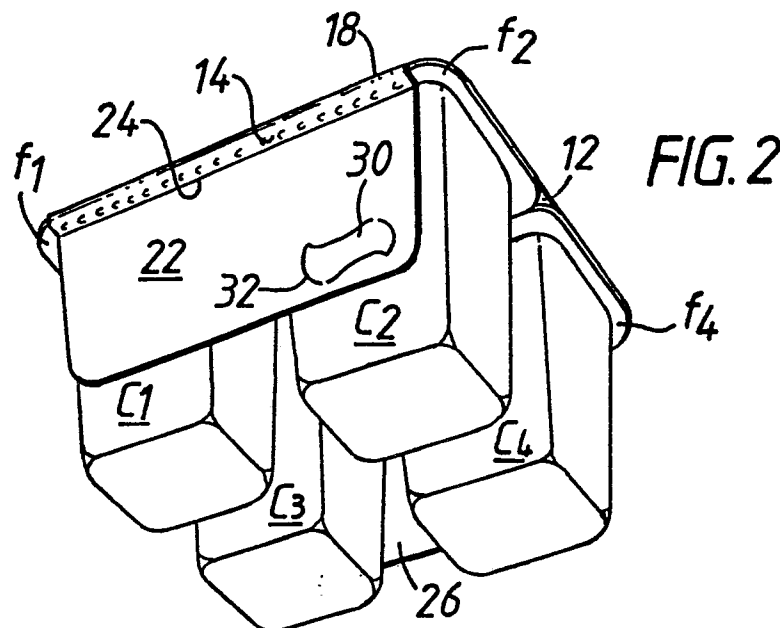

**EP 0 368 518 A1**

## MULTIPACKS FOR FLANGED CONTAINERS

This invention relates to a package which incorporates at least one primary container to which a blank of paperboard is applied.

EP-A-0 141 631 discloses a package comprising a group of flanged containers which has a paperboard cover including securing strips which are secured to the undersides of the container flanges by ultrasonic welding. The cover includes side panels which are left unattached from the container side walls and a readily detachable top wall connected to the securing strips. Thus a removable cover is secured to the containers without involving a gluing operation to effect securing the cover. The ultrasonic welding is effected to allow detachment of the cover without damage to the containers.

French Patent No 2 605 604 discloses a wraparound type package for a plurality of containers in which securing tabs are displaced out of the plane of the panel from which they are hinged and secured to adjacent containers to ensure that the articles are retained within the sleeve. The present invention is not concerned with a wraparound carton and does not at all depend upon "securing tabs" to retain containers in position.

The present invention offers a package in which a paperboard cover has side panels which are attached to the container side walls but which are readily detachable therefrom without damaging the container to which the side walls are attached or spoiling the appearance of the container.

One aspect of the invention provides a package incorporating a plurality of flanged containers arranged in rows and a paperboard blank in which the containers have flanges at the top ends thereof which interconnect adjacent containers and portions of which project outwardly, said blank including a top panel overlying the top of each container and side panel means including portions secured to the undersides of the outwardly projecting flanges in each row thereof to secure the containers and the blank together wherein each of said securing portions comprises a strip of material hinged to opposed side edges of said top panel and is folded into free contacting relationship with the undersides of said container flanges characterised in that at least one of said side panel portions has a part attached to said adjacent side of at least one of said containers, the attached part of said side panel portion being disposed substantially in the plane of said side panel and frangibly connected to the remaining part of said side panel portion whereby said remaining part can be detached leaving said attached part secured to said adjacent side of that container.

According to a feature of the invention, said side panel means may comprise a continuous panel flanking said adjacent exposed side of each container. Alternatively, the side panel means may comprise a series of flaps flanking the adjacent exposed sides of each container. Where this feature is adopted, said side panel flaps of each side panel may be connected one to the next by a frangible connection. Preferably, said attached part is small in relation to said remaining part of the side panel portion.

Another aspect of the invention provides a blank for forming a package according to any of the three immediately preceding paragraphs, which blank comprises a main central panel, a securing strip by which the blank is adapted to be attached to the top flanges of a group of flanged containers hinged to each of two opposite end edges of the main central panel, and end panels hinged to the end edge of said securing strips remote from the main central panel, each end panel including a part which is readily detached from the remaining portion of that panel by means of a frangible connection therebetween.

An embodiment of the invention will now be described, by way of example, with reference to the accompanying drawings, in which:-

FIGURE 1 is a plan view of a paperboard blank incorporated in a package according to the invention;

FIGURE 2 is a perspective view of a package according to the invention as seen from below and from one end; and

FIGURE 3 is a view similar to Figure 2 but in which one side wall panel is raised and broken away from an attached portion thereof which is left adhered to a container.

Referring first to Figure 1 of the drawings, there is shown an elongate blank 10 formed from paperboard or similar foldable sheet material and which comprises a top panel 12 to each of the transverse edges of which is hinged integral securing strips 14 and 16 along score lines 18 and 20, respectively. A side panel 22 is hinged to securing strip 14 along score line 24 and a side panel 26 is hinged to securing strip 16 along score line 28. Side panel 22 is formed with a partially cut out attachment part 30 adjacent the free end edge 22a of side panel 22 which frangibly is connected to the remainder of side panel 22 by cut and/or score lines 32 defining the peripheral edge of the attachment part. Likewise, side panel 26 is formed with a partially cut out attachment part 34 adjacent the free end edge 26a of side panel 26 and which frangibly is connected to the remainder of side

panel 26 by cut and/or score lines 36 defining the peripheral edge of the attachment part 34.

To form the completed package illustrated in Figure 2 of the drawings, the blank is applied to a group of containers C1-C4 each of which is connected to an adjacent container by its flange f1-f4 so that the top panel 12 lies on the tops of the containers in the group. The securing strips 14 and 16 are then brought into overlapping relationship with, and secured to (as by gluing) the underfaces of the flanges f of the containers by folding the blank along fold lines 18, 24 and 20, 28. The securing strip 14 is secured to the underface of outwardly extending parts of flanges f1 and f2 and similarly securing strip 16 is secured to the underface of outwardly extending parts of flanges f3 and f4. This folding operation also brings the side panel 22 into abutment with the exposed side walls of the adjacent containers C1 and C2 and the side panel 26 into abutment with the exposed side walls of the adjacent containers C3 and C4.

In order to maintain panels 22 and 26 against the sides of the adjacent containers, attachment part 30 of panel 22 is secured (as by gluing) to the side wall of container C2 and likewise attachment part 34 of panel 26 is secured (as by gluing) to the side wall of the diagonally opposite container C3. Of course, either or both the side panel 22 and 26 may include further attachment parts by which attachment is made to each of the adjacent containers. It is also envisaged that the shape and/or size and/or position of the attachment part may differ from the illustrated example.

Figure 3 shows the side panel 22 raised away from the side walls of containers C1 and C2 after which it can be detached from securing strip 14 by tearing along cut/score line 24. The action of lifting side panel 22 breaks the frangible connection with the attachment part 30 so that attachment part 30 is left secured to the side wall of container C2 and aperture 30a is created in panel 22 as shown. Side panel 26 can be manipulated in a similar manner thereby leaving attachment part 34 secured to the side wall of container C4. Each of the attachment parts hides the glued connection between its back face and the adjacent container wall and conveniently may display a trademark or other desired information on the container side wall. The top panel 12 may be readily detached from the securing strips 14 and 16 by tearing along cut/score lines 18 and 20 whereafter the individual containers may be separated from one another.

In a modified embodiment (not shown) it is envisaged that the blank 10 is of similar construction to that previously described but has side panels comprising a series of connected flaps. Thus, the blank includes a top panel to each of the transverse edges of which is hinged integral secur-

ing strips and a composite side panel is hinged to each of the securing strips in which each side panel comprises a series of flaps connected one to the next along frangible connections.

5

## Claims

10

15

20

25

30

35

40

45

50

55

1. A package incorporating a plurality of flanged containers (C) arranged in rows and a paperboard blank (10) in which the containers have flanges (f) at the top ends thereof which interconnect adjacent containers and portions of which project outwardly, said blank including a top panel (12) overlying the top of each container and side panel means (22, 26) including portions (14, 16) secured to the undersides of the outwardly projecting flanges in each row thereof to secure the containers and the blank together wherein each of said securing portions comprises a strip of material hinged to opposed side edges of said top panel and is folded into free contacting relationship with the undersides of said container flanges characterised in that at least one (26) of said side panel portions has a part (30, 34) attached to said adjacent side of at least one of said containers (C2), the attached part of said side panel portion being disposed substantially in the plane of said side panel and frangibly connected to the remaining part of said side panel portion whereby said remaining part can be detached leaving said attached part secured to said adjacent side of that container.

2. A package according to claim 1, further characterised in that said side panel means comprises a continuous panel flanking said adjacent exposed side of each container.

3. A package according to claim 1 further characterised in that the side panel means comprises a series of flaps flanking the adjacent exposed sides of each container.

4. A package according to claim 3, further characterised in that said side panel flaps of each side panel are connected one to the next by a frangible connection.

5. A package according to any of the preceding claims, further characterised in that said attached part is small in relation to said remaining part of the side panel portion.

6. A blank (10) for forming a package according to any of the preceding claims, which blank comprises a main central panel (12), a securing strip (14, 16) by which the blank is adapted to be attached to the top flanges of a group of flanged containers hinged to each of two opposite end edges of the main central panel, and end panels (22, 26) hinged to the end edge of said securing strips remote from the main central panel, each end panel including a part (30, 34) which is readily

detached from the remaining portion of that panel by means of a frangible connection (32, 36) therebetween.

5

10

15

20

25

30

35

40

45

50

55

4

FIG. 1

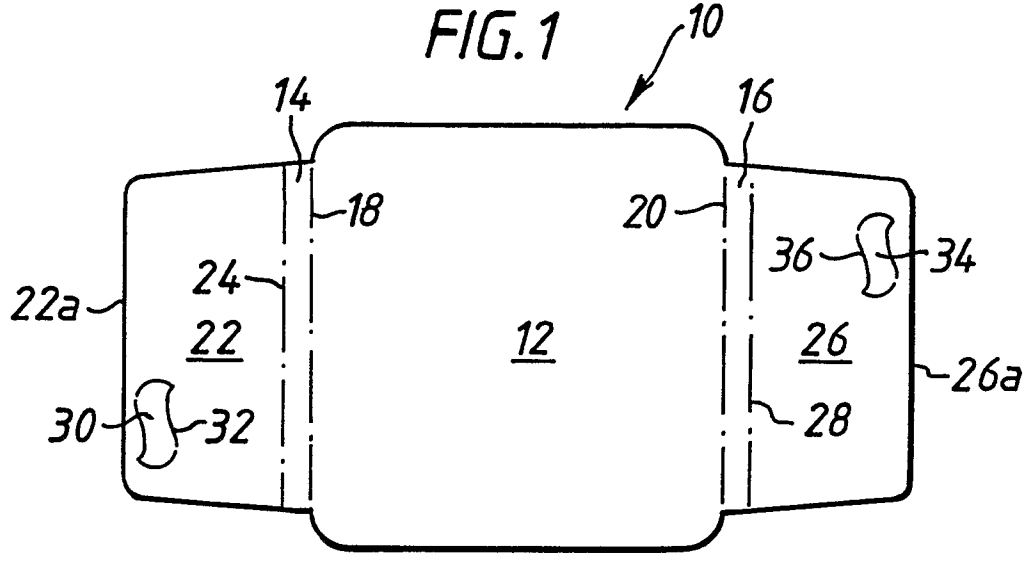

FIG. 2

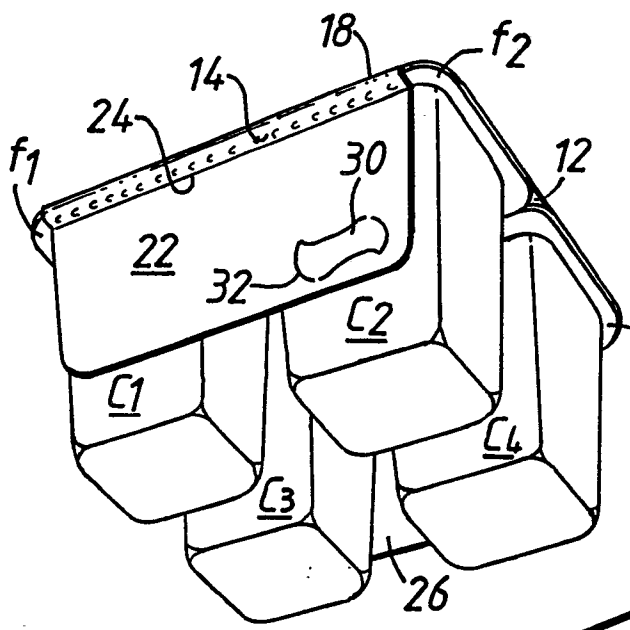
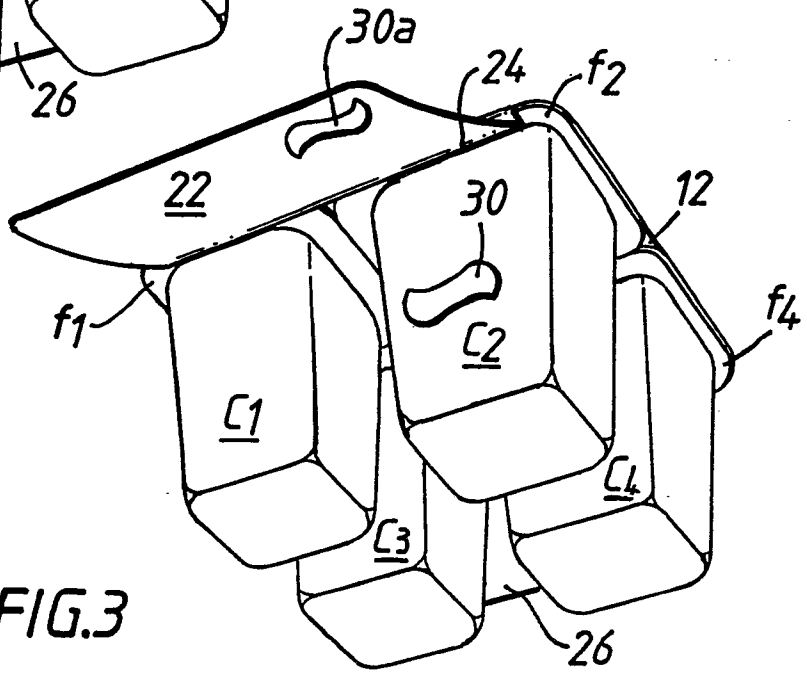

FIG. 3





DOCUMENTS CONSIDERED TO BE RELEVANT			
Category	Citation of document with indication, where appropriate, of relevant passages	Relevant to claim	CLASSIFICATION OF THE APPLICATION (Int. Cl.5)
D,A	EP-A-0 141 631 (MEAD CORP.) * Page 3, line 1 - page 4, line 12; figures 1-5 *	1,2,3,4 ,6	B 65 D 71/42
A	FR-A-2 444 624 (CENTRE D'ETUDES TECHNIQUES ET DE REALISATIONS APPLIQUEES) * Page 3, lines 23-40; figure 1 *	1	
A	US-A-3 404 912 (WATTS) * Column 3, line 3 - column 4, line 34; figures 1-3 *	1	
A	GB-A-2 107 269 (METALBOX)		
A	FR-A-2 111 194 (TANZER)		
			TECHNICAL FIELDS SEARCHED (Int. Cl.5)
			B 65 D
The present search report has been drawn up for all claims			
Place of search THE HAGUE		Date of completion of the search 17-01-1990	Examiner MARTENS L.G.R.
CATEGORY OF CITED DOCUMENTS		T : theory or principle underlying the invention E : earlier patent document, but published on, or after the filing date D : document cited in the application L : document cited for other reasons ..... & : member of the same patent family, corresponding document	
X : particularly relevant if taken alone Y : particularly relevant if combined with another document of the same category A : technological background O : non-written disclosure P : intermediate document			