



US 20090148314A1

(19) **United States**

(12) **Patent Application Publication**
Koitabashi et al.

(10) **Pub. No.: US 2009/0148314 A1**

(43) **Pub. Date: Jun. 11, 2009**

(54) **SCROLL FLUID MACHINE**

(30) **Foreign Application Priority Data**

(75) Inventors: **Yoshitaka Koitabashi**, Saitama (JP); **Kou Tsukamoto**, Gunma (JP); **Tomokazu Naruta**, Gunma (JP); **Shigeyuki Koyama**, Gunma (JP)

Apr. 1, 2005 (JP) 2005-106098

Publication Classification

Correspondence Address:
COHEN, PONTANI, LIEBERMAN & PAVANE LLP
551 FIFTH AVENUE, SUITE 1210
NEW YORK, NY 10176 (US)

(51) **Int. Cl.**
F04C 29/04 (2006.01)
F04C 18/02 (2006.01)

(52) **U.S. Cl. 417/366; 417/368; 417/372; 417/410.5**

(73) Assignee: **SANDEN CORPORATION**, Gunma (JP)

(57) **ABSTRACT**

(21) Appl. No.: **11/887,691**

An electric motor-driven scroll compressor as a fluid machine includes a housing (10) containing a scroll unit (20) and an armature (38) for driving the scroll unit (20), and a refrigerant conduit located inside the housing (10) to guide a refrigerant toward the scroll unit (20). The refrigerant conduit includes a helical groove (64) as part thereof. The helical groove (64) is formed in the outer peripheral surface of a rotor (54) constituting the armature (38) and has opposite ends opening in the respective opposite end faces of the rotor (54).

(22) PCT Filed: **Mar. 29, 2006**

(86) PCT No.: **PCT/JP2006/306507**

§ 371 (c)(1),
(2), (4) Date: **Oct. 1, 2007**

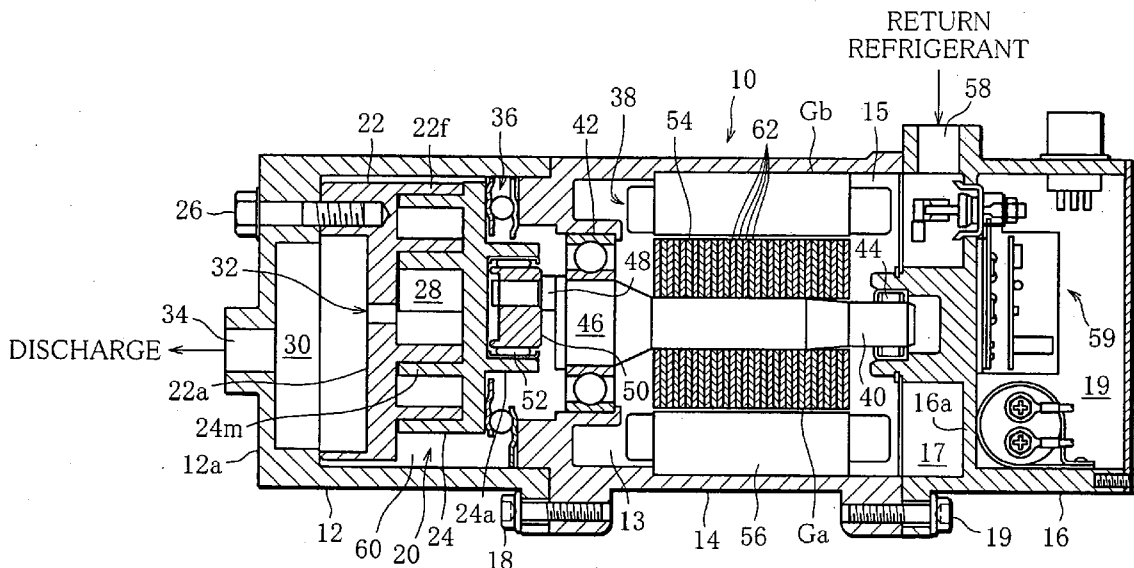

FIG. 2

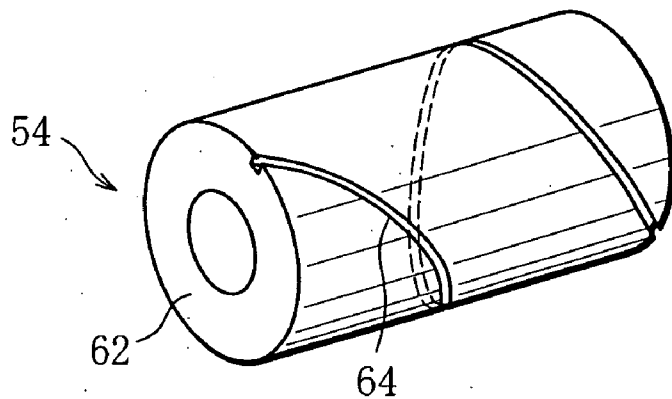
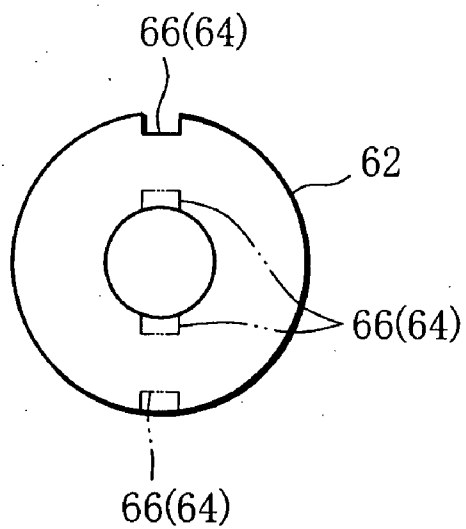

FIG. 3



SCROLL FLUID MACHINE

TECHNICAL FIELD

[0001] The present invention relates to scroll fluid machines, and more particularly, to a scroll fluid machine suited for use as a scroll compressor incorporated in a refrigeration circuit of an automotive air-conditioning system to compress a refrigerant.

BACKGROUND ART

[0002] A scroll compressor of this type is driven by the engine or electric motor of a motor vehicle. Compared with the engine-driven compressor, the electric motor-driven compressor is easy to adjust the displacement of the refrigerant, irrespective of engine load, and thus is superior in that the temperature in the passenger compartment of the vehicle can be finely controlled.

[0003] Also, since this type of scroll compressor is mounted on a vehicle, there has been a demand for a compressor as compact in size as possible. An electric motor-driven scroll compressor disclosed in Unexamined Japanese Patent Publication No. 2003-129983 includes a housing used in common for the scroll unit and the electric motor, and the scroll unit and the armature of the electric motor are contained in the common housing.

[0004] During rotation of the electric motor, the armature generates heat, and if the temperature of the armature excessively rises, the performance of the motor lowers. Accordingly, the compressor disclosed in the above publication includes a cooling passageway for the armature. The cooling passageway guides the refrigerant to the armature before the refrigerant is returned to the scroll unit. Since the temperature of the return refrigerant is considerably lower than the ambient temperature, the armature can be effectively cooled by the return refrigerant.

[0005] Specifically, the cooling passageway includes an air gap between the rotor and stator of the armature, a gap between the stator and the inner peripheral wall of the common housing, and gaps between stator coils. These gaps are, however, so narrow that the cooling passageway constitutes a large resistance to the flow of the refrigerant flowing toward the scroll unit, increasing the pressure loss of the refrigerant. Consequently, the scroll unit is unable to efficiently suck in the return refrigerant, so that the suction efficiency of the scroll unit lowers.

[0006] To eliminate the inconvenience, a motor disclosed in Unexamined Japanese Patent Publication No. 2002-165406 has an armature provided with an axial passage extending through the rotor as well as with fans attached to the respective opposite end faces of the rotor. As the fans rotate, the refrigerant is forced to flow through the axial passage in one direction, thus cooling the armature.

[0007] Where the armature disclosed in the above publication is applied to a scroll compressor, however, the size of the armature increases by an amount corresponding to the axial passage formed through the rotor, which entails increase in the outside diameter and weight of the common housing of the scroll compressor. Further, the use of the fans leads to an increased number of component parts of the armature, increasing the cost of the scroll compressor.

DISCLOSURE OF THE INVENTION

[0008] An object of the present invention is to provide a scroll fluid machine capable of enhancing the suction effi-

ciency of a scroll unit thereof without entailing increase in size or in the number of component parts.

[0009] To achieve the object, the present invention provides a scroll fluid machine comprising: a housing; a scroll unit contained in the housing, the scroll unit having a fixed scroll and a movable scroll cooperating with each other to compress a working fluid; an armature contained in the housing adjacently to the scroll unit and including a rotor for revolving the movable scroll, the rotor having a peripheral surface and opposite end faces; and a fluid conduit located inside the housing to guide the working fluid toward the scroll unit through the armature and including a helical groove formed in the peripheral surface of the rotor, the helical groove having opposite ends opening in the respective opposite end faces of the rotor.

[0010] In the scroll fluid machine constructed as above, as the scroll unit is driven by the armature, the working fluid guided through the fluid conduit is sucked into the scroll unit. The pressure of the working fluid thus sucked in changes while the working fluid passes through the scroll unit, and then the working fluid is discharged from the scroll unit.

[0011] The fluid conduit includes the helical groove formed on the rotor, and thus, a major part of the working fluid supplied to the scroll unit flows through the helical groove. The helical groove increases the cross-sectional area of the fluid conduit, and therefore, the fluid conduit does not constitute a large resistance to the flow of the working fluid flowing toward the scroll unit. As a result, the pressure loss of the working fluid is reduced and the working fluid suction efficiency of the scroll unit improves.

[0012] Preferably, the helical groove has a helix direction such that when the rotor is rotated, the working fluid in the helical groove is forced toward the scroll unit. In this case, while the rotor is rotating, the working fluid in the helical groove is constantly forced toward the scroll unit. Accordingly, the working fluid is forced to flow through the helical groove toward the scroll unit, thus making it possible not only to further reduce the pressure loss of the working fluid but to further enhance the suction efficiency of the scroll unit.

[0013] Specifically, the scroll unit is a compression unit for a refrigeration circuit, and the fluid conduit guides a refrigerant to be returned to the compression unit. Preferably, in this case, the peripheral surface of the rotor having the helical groove formed therein is an outer peripheral surface of the rotor.

[0014] The temperature of the refrigerant being returned to the compression unit is considerably lower than the ambient temperature, and therefore, when the refrigerant flows through the helical groove of the rotor, the armature is effectively cooled by the refrigerant. Consequently, the armature is prevented from being overheated, whereby the performance of the armature is maintained.

[0015] The rotor may have a laminated structure obtained by laminating ring-shaped magnetic steel sheets one upon another in an axial direction of the rotor, and each magnetic steel sheet may have a helical groove-forming notch cut in a peripheral edge thereof constituting the peripheral surface of the rotor. In this case, the helical groove can be easily formed in the peripheral surface of the rotor.

BRIEF DESCRIPTION OF THE DRAWINGS

[0016] FIG. 1 is a sectional view of a scroll compressor as a fluid machine.

[0017] FIG. 2 is a perspective view of a rotor appearing in FIG. 1.

[0018] FIG. 3 is a front view of a magnetic steel sheet constituting the rotor of FIG. 2.

BEST MODE OF CARRYING OUT THE INVENTION

[0019] A scroll compressor shown in FIG. 1 is used in an automotive air-conditioning system, that is, in a refrigeration circuit. The compressor has a cylindrical housing 10. The housing 10 has a unit casing 12, a motor casing 14, and a circuit casing 16 arranged in this order as viewed from left to right in FIG. 1. The unit casing 12 and the motor casing 14 are coupled together by a plurality of connecting bolts 18, and the motor casing 14 and the circuit casing 16 are also coupled together by a plurality of connecting bolts 19.

[0020] The unit casing 12 contains a scroll unit 20 having a fixed scroll 22 and a movable scroll 24. The fixed scroll 22 is abutted against an end wall 12a of the unit casing 12 and fixed to the end wall 12a by fixing bolts 26. The movable scroll 24 is located close to the motor casing 14.

[0021] The fixed and movable scrolls 22 and 24 have respective spiral walls 22f and 24m engaged with each other. The spiral walls 22f and 24m thus engaged with each other define a plurality of compression chambers 28 therebetween. As the movable scroll 24 revolves about the fixed scroll 22, the compression chambers 28 spirally move in the circumferential direction toward the center of the fixed scroll 22, and in the process of movement, the capacities of the compression chambers 28 decrease by degrees.

[0022] The unit casing 12 has a discharge chamber 30 defined therein. The discharge chamber 30 has its end walls constituted by the end wall 12a of the unit casing 12 and an end plate 22a of the fixed scroll 22, respectively. The end plate 22a has a discharge hole 32 formed through the center thereof. The discharge hole 32 is opened and closed by a discharge valve (not shown). The discharge valve is arranged inside the discharge chamber 30 and fixed to the end plate 22a of the fixed scroll 22.

[0023] Further, the unit casing 12 has a discharge port 34 formed in its end wall 12a. The discharge port 34 has an inner end communicating with the discharge chamber 30 and has an outer end connected to a refrigerant circulation path (not shown) of the refrigeration circuit, or more specifically, to a condenser (not shown) of the refrigeration circuit through the refrigerant circulation path.

[0024] The movable scroll 24 is allowed to revolve but is prevented from rotating on its axis. More specifically, a ball coupling 36 is interposed between an end plate 24a of the movable scroll 24 and one end of the motor casing 14. The ball coupling 36 prevents the movable scroll 24 from rotating on its axis and at the same time transmits the thrust load of the movable scroll 24 to the motor casing 14.

[0025] On the other hand, the motor casing 14 contains an armature 38. The armature 38 partitions the interior of the motor casing 14 into a chamber 13 close to the unit casing 12 and a chamber 15 close to the circuit casing 16. Also, the armature 38 has a rotary shaft 40 located at the center of the motor casing 14 and extending from the one end of the motor casing 14 to the circuit casing 16. The rotary shaft 40 is rotatably supported at opposite ends by the one end of the motor casing 14 and a partition wall 16a of the circuit casing 16 through a ball bearing 42 and a roller bearing 44, respectively. The partition wall 16a partitions the interior of the

circuit casing 16 into a chamber 17 communicating with the interior of the motor casing 14 and a circuit chamber 19 separated from the chamber 17.

[0026] As is clear from FIG. 1, the rotary shaft 40 has a large-diameter portion 46 formed at one end thereof. The large-diameter end portion 46 has an end face facing the end plate of the movable scroll 24. A crankpin 48 protrudes from the end face of the large-diameter end portion 46 toward the movable scroll 24, and an eccentric bushing 50 is fitted on the crankpin 48. The eccentric bushing 50 is rotatably supported by a boss 24a of the movable scroll 24 through a needle bearing 52.

[0027] When the rotary shaft 40 is rotated, the rotational force thereof is transmitted through the crankpin 48, the eccentric bushing 50 and the needle bearing 52 to the movable scroll 24. Consequently, the movable scroll 24 revolves about the fixed scroll 22 while being prevented from rotating on its axis by the ball coupling 36. The revolving radius of the movable scroll 24 is determined by the distance between the axis of the rotary shaft 40 and the axis of the crankpin 48.

[0028] The armature 38 has a rotor 54 mounted on the rotary shaft 40. The rotor 54 is surrounded by a stator 56 fixed to the inner peripheral wall of the motor casing 14.

[0029] On the other hand, the circuit casing 16 has a return port 58 formed in its outer peripheral wall. The return port 58 has an inner end communicating with the interior of the motor casing 14, that is, the chamber 15, through the chamber 17 of the circuit casing 16. The other end of the return port 58 is connected to the refrigerant circulation path of the refrigeration circuit, or more specifically, to an evaporator of the refrigeration circuit through the refrigerant circulation path. Accordingly, the return refrigerant delivered from the evaporator flows through the return port 58 into the chamber 17 in the circuit casing 16 and then is supplied from the chamber 17 to the interior of the motor casing 14.

[0030] A driver circuit 59 for the armature 38 is arranged in the circuit chamber 19 of the circuit casing 16. The driver circuit 59 controls the supply of electric power to the armature 38 and thus the rotation of the armature 38.

[0031] A cooling conduit is provided in the motor casing 14 and serves to guide the return refrigerant supplied to the motor casing 14 through the armature 38. Specifically, the cooling conduit includes a helical groove as its principal part, besides an air gap Ga between the rotor 54 and the stator 56, a gap Gb between the inner peripheral wall of the motor casing 14 and the outer peripheral wall of the stator 56, and gaps (not shown) between stator coils. These gaps and the helical groove interconnect the chambers 13 and 15 located on the opposite sides of the armature 38.

[0032] The helical groove will be now described in detail. As is clear from FIG. 1, the rotor 54 has a laminated structure obtained by laminating numerous ring-shaped magnetic steel sheets 62 one upon another in the axial direction of the rotary shaft 40. The helical groove 64, shown in FIG. 2, is formed in the outer peripheral surface of the rotor 54 and has opposite ends opening in the respective opposite end faces of the rotor 54. More specifically, the helical groove 64 has a helix direction similar to that of a right-handed screw such that when the rotor 54 is rotated, the groove makes motion advancing toward the unit casing 12.

[0033] In the rotor 54 of this embodiment, each magnetic steel sheet 62 has a U-shaped notch 66 cut in an outer peripheral surface thereof. When the rotor 54 is formed using a large number of such magnetic steel sheets 62, the magnetic steel

sheets 62 are laminated one upon the other such that the notches 66 of adjacent magnetic steel sheets are slightly shifted in the circumferential direction of the rotor 54, whereby the helical groove 64 is formed by the notches 66 contiguous with each other in the axial direction of the rotor 54.

[0034] Alternatively, the helical groove 64 may be formed by mechanically machining the outer peripheral surface of the rotor 54 after the rotor 54 is prepared by laminating a large number of magnetic steel sheets 62.

[0035] On the other hand, the unit casing 12 has a suction chamber 60 for the scroll unit 20 defined therein. The suction chamber 60 surrounds the movable scroll 24 of the scroll unit 20 and is separated from the aforementioned discharge chamber 30 by the fixed scroll 22. The suction chamber 60 is connected with the chamber 13 in the motor casing 14 through the internal space of the ball coupling 36, the space between the movable scroll 24 and the ball bearing 42, and the internal space of the ball bearing 42. Accordingly, the suction chamber 60 is connected with the return port 58 of the circuit casing 16 through a refrigerant conduit including the aforementioned cooling conduit, whereby the return refrigerant flowing into the return port 58 is supplied to the suction chamber 60 through the refrigerant conduit.

[0036] When the rotary shaft 40 of the armature 38 is rotated, the rotation thereof is transmitted to the movable scroll 24 through the crankpin 48 and the eccentric bushing 50. Consequently, the movable scroll 24 revolves about the fixed scroll 22 while being prevented from rotating on its axis. As the movable scroll 24 revolves, one compression chamber 28 opens into the suction chamber 60 to be supplied with the refrigerant and is then shut off from the suction chamber 60.

[0037] The compression chamber 28 thereafter moves toward the discharge hole 32 of the fixed scroll 22 as the movable scroll 24 further revolves, and since the capacity of the compression chamber 28 decreases in the process of revolution, the refrigerant sucked in the compression chamber 28 is compressed. The compression chamber 28 then reaches the discharge hole 32, and when the refrigerant pressure in the compression chamber 28 surpasses the valve closing pressure of the discharge valve, the discharge valve opens, whereupon the compressed refrigerant in the compression chamber 28 is discharged to the discharge chamber 30 through the discharge hole 32.

[0038] The compressed refrigerant in the discharge chamber 30 is delivered through the discharge port 34 to the refrigerant circulation path and supplied to the condenser of the refrigeration circuit. Subsequently, the compressed refrigerant is supplied via a receiver and an expansion valve in the refrigerant circulation path to the evaporator, which returns the refrigerant to the return port 58. The refrigerant thus returned to the return port 58 flows into the chamber 17 in the circuit casing 16 and then is supplied to the suction chamber 60 through the aforementioned refrigerant conduit, namely, the cooling conduit.

[0039] The temperature of the return refrigerant is considerably lower than the ambient temperature, as stated above, and therefore, the return refrigerant effectively cools the armature 38 while passing through the cooling conduit, thus preventing the armature 38 from becoming overheated.

[0040] The cooling conduit includes the helical groove 64 as its principal part and the helical groove 64 serves to increase the effective cross-sectional flow area of the cooling conduit as a whole. Consequently, the cooling conduit does

not constitute a large resistance to the flow of the return refrigerant flowing toward the suction chamber 60, so that the pressure loss of the return refrigerant is small.

[0041] Further, since the helical groove 64 rotates together with the rotor 54, the return refrigerant in the helical groove 64 is forced to move toward the unit casing 12, thus producing a flow of the return refrigerant in the helical groove 64 directed from the chamber 15 to the chamber 13 of the motor casing 14.

[0042] As a result, not only the armature 38 is effectively cooled by the forced flow of the return refrigerant but also the suction chamber 60 is supplied with an increased amount of the return refrigerant. Accordingly, the suction efficiency of the scroll unit 20 is enhanced, making it possible to improve the performance of the scroll compressor.

[0043] The helical groove 64 does not entail increase in the diameter of the rotor 54 or in the number of component parts of the armature 38, so that the scroll compressor need not be increased in size. Furthermore, the weight of the scroll compressor can be reduced.

[0044] The present invention is not limited to the foregoing embodiment and may be modified in various ways.

[0045] For example, as indicated by the dot-dot-dash lines in FIG. 3, the rotor 54 may have a plurality of helical grooves 64 formed in the outer peripheral surface thereof. Also, one or more helical grooves 64 may be formed in the inner peripheral surface of the rotor, instead of the outer peripheral surface of same.

[0046] Further, the present invention is equally applicable to a scroll expander, besides the compressor.

1. A scroll fluid machine comprising:

a housing;

a scroll unit contained in said housing, said scroll unit having a fixed scroll and a movable scroll cooperating with each other to compress a working fluid;

an armature contained in said housing adjacently to the scroll unit and including a rotor for revolving the movable scroll, the rotor having a peripheral surface and opposite end faces; and

a fluid conduit located inside said housing to guide the working fluid toward said scroll unit through the armature and including a helical groove formed in the peripheral surface of the rotor, the helical groove having opposite ends opening in the respective opposite end faces of the rotor.

2. The scroll fluid machine according to claim 1, wherein the helical groove has a helix direction such that when the rotor is rotated, the working fluid in the helical groove is forced toward said scroll unit.

3. The scroll fluid machine according to claim 2, wherein said scroll unit is a compression unit for a refrigeration circuit, and said fluid conduit guides a refrigerant to be returned to said compression unit.

4. The scroll fluid machine according to claim 2, wherein the peripheral surface of the rotor is an outer peripheral surface of the rotor.

5. The scroll fluid machine according to claim 4, wherein said scroll unit is a compression unit for a refrigeration circuit, and the fluid conduit guides a refrigerant to be returned to said compression unit.

6. The scroll fluid machine according to claim 2, wherein the rotor has a laminated structure obtained by laminating ring-shaped magnetic steel sheets one upon another in an axial direction of the rotor, and each of the magnetic steel

sheets has a helical groove-forming notch cut in a peripheral edge thereof constituting the peripheral surface of the rotor.

* * * * *