

No. 668,352.

Patented Feb. 19, 1901.

G. A. HEIMBUCHER.

DEVICE FOR OPERATING FANS ON ROCKING CHAIRS.

(Application filed Aug. 18, 1899.)

(No Model.)

2 Sheets—Sheet 1.

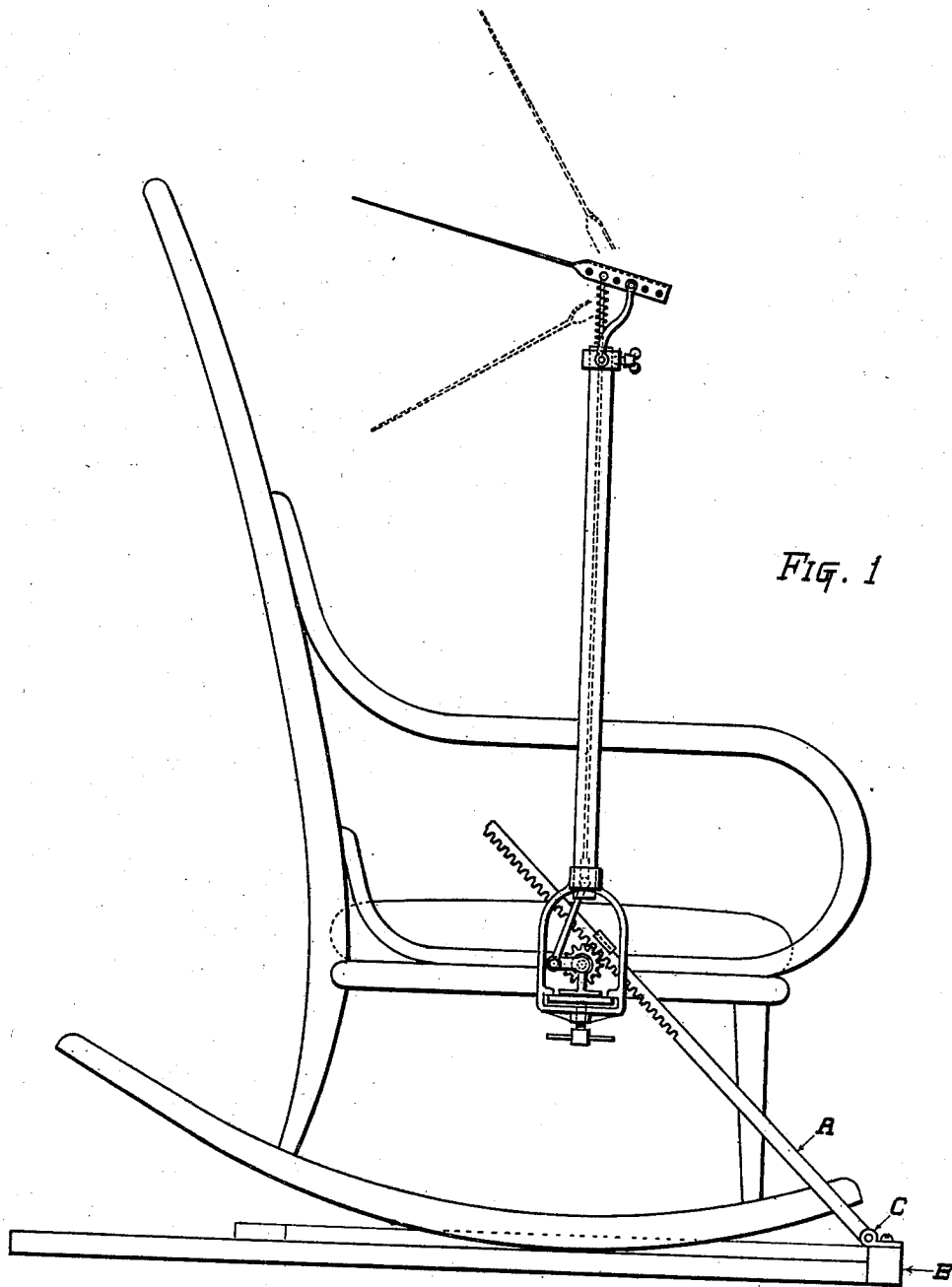

FIG. 1

WITNESSES:
Anthony Frank Postel
J. H. Hoff

INVENTOR.
G. A. Heimbuher

No. 668,352.

G. A. HEIMBUCHER.

Patented Feb. 19, 1901.

DEVICE FOR OPERATING FANS ON ROCKING CHAIRS.

(No Model.)

(Application filed Aug. 18, 1899.)

2 Sheets—Sheet 2.

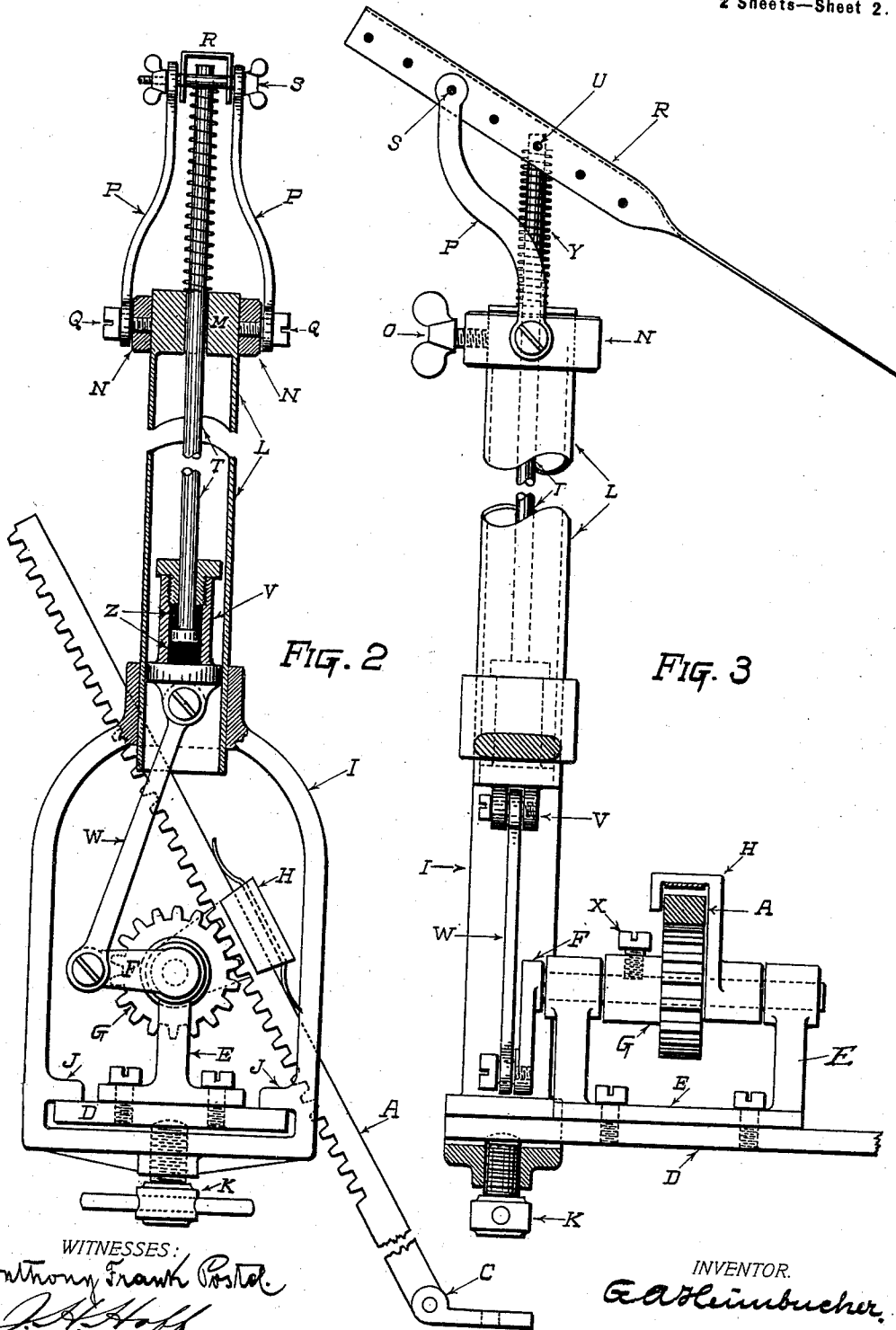

FIG. 2

FIG. 3

WITNESSES:
Anthony Frank Postel
J. A. Hoff

INVENTOR.
G. Heimbuher.

UNITED STATES PATENT OFFICE.

GOTTLIEB A. HEIMBUCHER, OF CHICAGO, ILLINOIS.

DEVICE FOR OPERATING FANS ON ROCKING-CHAIRS.

SPECIFICATION forming part of Letters Patent No. 668,352, dated February 19, 1901.

Application filed August 18, 1899. Serial No. 727,640. (No model.)

To all whom it may concern:

Be it known that I, GOTTLIEB A. HEIMBUCHER, a citizen of the United States, residing at Chicago, in the county of Cook and State of Illinois, have invented certain new and useful Improvements in Devices for Operating Fans on Rocking-Chairs, of which the following is a full, clear, and exact specification.

My invention relates to that class of devices designed to be operated by the natural rocking movement of a rocking-chair whereby the occupant thereof may receive the benefit of the fan without the expenditure of extra effort or the exercise of special attention for its operation.

The primary object of my invention is to provide an improved and simple device whereby a fan may be kept in motion on a rocking-chair as long as the occupant thereof rocks back and forth, a further object being to make the device noiseless and easily adapted and adjusted to the chair.

With these ends in view my invention consists in certain features of novelty in the construction, combination, and arrangement of parts by which the said objects and certain other objects hereinafter appearing are attained, all as fully described with reference to the accompanying drawings, and more particularly pointed out in the claims.

In the said drawings, Figure 1 is a side elevation of a rocking-chair with my improvements applied thereto. Fig. 2 is an enlarged vertical sectional view, partly broken away, of the attachment; and Fig. 3 is a front view partly in vertical section and partly broken away.

B is the ordinary base of a rocking-chair, to which I attach the lower end of a rack-bar A by means of any suitable joint C, and to the under side of the rocking-chair bottom I secure a strip D, which serves as a bracket, projecting slightly from the side of the chair and affording support for a pinion G, mounted upon a shaft journaled in standards E, which are secured by screws or other suitable devices to the bracket portion D. On one side of the pinion G is located a guide H, which embraces the back of the rack-bar A and is journaled upon the pinion-shaft, so as to hold the rack-bar in engagement with the pinion

while permitting it to oscillate with the chair. One end of the pinion-shaft is connected by crank F to the lower end of a link W, whose upper end is secured to a cross-head V, which runs in a guide-tube L or hollow standard, supported on a frame I. This cross-head V is in the form of a chamber and serves as a housing for a piston on the lower end of a vertical rod T, above and below which is an elastic substance Z, whereby a yielding or elastic connection between the cross-head and the rod T is produced. The upper end of the rod T passes through a guide M on the handle or stem of a fan R, which stem, as clearly shown in Fig. 3, is provided with a series of perforations for the passage of the pin U, whereby the degree of oscillation of the fan may be varied at will. One of these perforations also serves for the passage of the pin S, which pivots to the stem R the upper ends of a pair of links P, whose lower ends are pivoted at Q to a collar N, held adjustably on the upper end of the tube L by set-screw O, so that the position of the fan may be altered at will—that is to say, by rotating the collar N upon the tube L the fan may be set transversely of the plane of oscillation of the chair, or it may be set longitudinally of such plane and at any intermediate angle between these two extremes. By this means the fan may also have its angle of inclination altered to suit the requirements, thus adapting it for persons of different height. When the chair is rocked, the pinion G will be rotated back and forth by its connection with the bar A, which is held against longitudinal movement by virtue of its fixed connection to the base B, and this rotary movement of the pin G will impart an up-and-down movement to the rod T, which communicates its movement to the fan-stem R, the downward movement of the rod T being resisted or cushioned by a spring Y, sleeved thereon between the pin U and the guide M for the purpose of taking up lost motion and balancing the mechanism.

The frame I branches around the crank F and link W, as clearly shown in Fig. 2, and each branch is provided with a lug J, resting upon the upper side of the board D, while the branches beneath the board are connect-

ed together and provided with a set-screw K, whereby the frame may be tightly clamped upon the board.

Having thus described my invention, what I claim as new, and desire to secure by Letters Patent, is—

1. In a device for the purpose described the combination of a rocking-chair, a fan having a stem, the pivoted links P pivotally connected with said stem, a standard, a collar adjustably supported on said standard and supporting said links, an operating-rod operatively connected with said stem and means for operating said rod by the rocking movement of the chair, substantially as set forth.

2. In a device for the purpose described the combination of a rocking-chair, a tube L vertically supported thereon and having guide M, collar N adjustably secured to said tube, a fan, links P pivoted to said fan and to said collar, rod T passing through guide M into said tube and being pivotally connected to said fan, a chambered cross-head located in said tube and housing one end of said rod, a pinion mounted on the chair and a rack-bar engaging said pinion and having one end fixed to cause it to rotate said pinion, substantially as set forth.

3. In a device for the purpose described the combination of a rocking-chair, a fan having a stem provided with a series of sockets or perforations, a pivoting-support pivoted in one of said perforations, an operating-rod pivoted in another of said perforations, an adjustable support for said pivotal support, and means for reciprocating said rod by the rocking movement of the chair, substantially as set forth.

4. In a device for the purpose described the combination of a rocking-chair, the board D secured to the chair and projecting from the side thereof, the bifurcated frame I having the lugs J resting upon said board and a portion extending under the board, the set-screw K impinging the bottom of said board, a cross-head, a guide for said cross-head carried by said frame, a fan actuated by said cross-head, a crank pivoted within said frame I and connected with said cross-head and means for rotating said crank by the rocking movement of the chair, substantially as set forth.

GOTTLIEB A. HEIMBUCHER.

Witnesses:

ANTHONY FRANK POSTEL,
J. H. HOFF.