



Europäisches Patentamt
European Patent Office
Office européen des brevets



(11) **EP 0 810 573 A1**

(12) **EUROPEAN PATENT APPLICATION**

(43) Date of publication:
03.12.1997 Bulletin 1997/49

(51) Int Cl.⁶: **G09F 9/37**

(21) Application number: **97303521.5**

(22) Date of filing: **23.05.1997**

(84) Designated Contracting States:
AT BE CH DE DK ES FI FR GB LI NL SE
Designated Extension States:
LT LV SI

(72) Inventor: **Sussi, Carlo c/o Presso Inso S.P.A.**
Firenze (IT)

(30) Priority: **31.05.1996 IT MI961109**

(74) Representative: **Pedder, James Cuthbert et al**
GE London Patent Operation,
Essex House,
12/13 Essex Street
London WC2R 3AA (GB)

(71) Applicant: **NUOVO PIGNONE S.p.A.**
50127 Firenze (IT)

(54) **Number indicator**

(57) A number indicator comprises a transparent sheet (A) with opaqued areas and seven transparent areas (A1-A7) representing the seven parts of the numeral "8". A flat support (B) for the transparent sheet (A) comprises seven cavities (B1-B7), each positioned to correspond with one part of the numeral. Seven opaque plates (E1,E2) are each associated with one of the transparent areas, (A1-A7) and are movable between a first position in which they obscure the respective transparent area (A1-A7) and a second position in which the respective transparent area (A1-A7) is unobscured. Magnetic means (D) are associated with each of the seven opaque plates (E1,E2) for enabling the plates (E1,E2) to be moved between their first and second positions. Over centre means (C) are mounted in the cavities (B1-B7) and are connected to each of the seven opaque plates (E1,E2) for biasing the plates (E1,E2) towards one or other of their two positions.

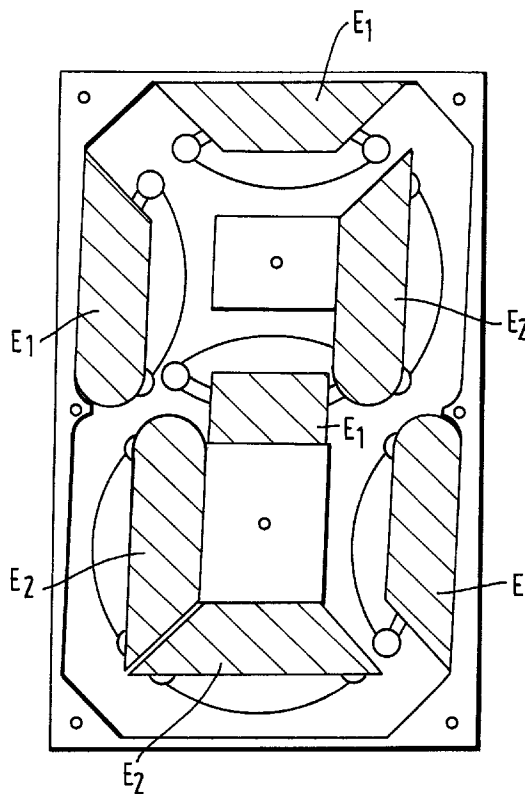

FIG. 4

EP 0 810 573 A1

Description

The present invention relates to a number indicator.

More specifically, the present invention relates to a number indicator, with manually controlled magnetic movement, for price lists.

As is known, commercial regulations impose on sellers of consumer goods the need to indicate the prices of the item for sale with appropriate price indicators.

In the case of consumer goods or merchandise introduced into the market with traditional methods of distribution, for example, shops, markets, supermarkets, etc., the above obligation is easily satisfied by applying the price on the product for sale. In other situations, however, this operation is not sufficient.

For example, in the sale of products such as fuels for road transport, the prices must be displayed not only on the distribution pumps, but also at the entrance of the filling station as an indication to drivers passing the station. In these cases therefore, the indicator displaying the prices of fuel at the filling station must be well in sight and of easy access to the salesman who must punctually up-date the selling-prices.

The indicators which form the sales prices of the fuel must consequently satisfy various requisites. As they are exposed to the open-air, they must have a good, long-lasting resistance to the action of atmospheric and polluting agents, they must be of such dimensions as to be visible from a distance, they must have a limited cost and, as already mentioned, they must be easily adjustable owing to the variations in the prices of fuels.

The Applicant has now invented a number indicator which can be used in the preparation of price-lists which can satisfy some or all of the above requisites. It can, in fact, be made by using a traditional polymeric material and can be easily controlled, from zero to nine, as it is equipped with a manually controlled magnetic operation.

According to the invention, there is provided a number indicator comprising:

- (a) a transparent sheet with opaqued areas and seven transparent areas, the transparent areas representing the seven parts of the numeral "8";
- (b) a flat support for the transparent sheet comprising seven cavities each positioned to correspond with one part of the numeral;
- (c) seven opaque plates each associated with one of said transparent areas and moveable between a first position in which in which they obscure the respective transparent areas and a second position in which the respective transparent areas are unobscured;
- (d) magnetic means associated with each of the seven opaque plates for enabling the plates to be moved between their first and second positions; and
- (e) over centre means mounted in the cavities and

connected to each of the seven opaque plates for biasing the plates towards one or other of their two positions.

5 Preferably the magnetic means comprise a metal chip made of ferromagnetic material attached to the associated plate.

The seven cavities may be elliptical and the over centre means may comprise a stop-spring centrally welded to each metal chip and, at the ends, to the apices of each elliptical cavity.

10 The flat sheet which may be serigraphed with black ink and the flat support may be joined to each other to form an article with an essentially rectangular surface of such dimensions as to be visible at a distance. In particular, the shorter side of this rectangular structure may be between 10 and 18 cm whereas the longer side may vary from 18 to 30 cm.

15 The transparent sheet can be made of glass or transparent polymeric material, for example polymethylmethacrylate. Suitably, it has a thickness of a few millimetres, for example 1-3 mm, and may be serigraphed with the known techniques.

20 In one embodiment of the invention, the flat support is made of polymeric material and is dyed with light colours, for example white or yellow, so that the figures can be clearly read through the non-serigraphed parts of the sheet. The support, made of polymeric material such as polyethylene, polypropylene, polymethylmethacrylate, etc. has a thickness of 5-15 mm. The cavities in the sheet can be obtained by milling a pre-extruded sheet or shaping, by injection moulding, a sheet already equipped with said cavities.

25 The stop-springs are lodged in the cavities of the supporting sheet, which, when not in use, have a length which is greater than the length of the major axis of the elliptical cavity and less than its semiperimeter.

30 A ferromagnetic metal chip is welded to each spring, which can be moved manually with a permanent magnet. As the stop-spring is lodged in the cavity and is fixed at the ends of this, the movement of the metal chip can occur only with orthogonal motions towards the longer axis of the elliptic cavity.

35 A black thin plate is firmly attached to each metal chip, shaped so as to reproduce the form of the corresponding digital character (or numeral part) on the serigraphed sheet. Each thin plate is attached to the metal chip in such a way that it is in line with each character of the digital number. When the metal chip moves, by effect of the magnet, it also pulls the black thin plate which, when the movement has stopped, can cover or reveal the character of the digital number, thus forming any figure from zero to nine. It is evident that for the thin plate to be perfectly superimposed on the digital character there must be precise correspondence between the digital number displayed on the transparent sheet and the elliptic cavities on the flat support.

40 Night visibility of the figure displayed on the indica-

tor of the present invention can be ensured by a light source positioned behind the flat support. Alternatively it is possible to treat the support with a refrangible paint which refracts the light coming from an external source, for example headlights of a car.

The invention will now be described in greater detail, by way of example, with reference to the drawings in which:

Figure 1 shows a representation of the transparent serigraphed sheet;

Figure 2 shows a representation of the flat support shaped with elliptic cavities;

Figure 3 shows a representation of the flat support comprising stop-springs welded to metal chips;

Figure 4 shows a representation of the flat support with the black thin plates applied to the metal chips.

With reference to the figures, (A) represents the transparent sheet serigraphed with black ink to allow the transparent reading of the number eight according to the digital figures (A1)-(A7). (B) represents the flat support with the cavities (B1)-(B7) reproduced on the surface. Stop-springs (C) are lodged in the cavities, fixed to the ends (C1)-(C7) at the apices (b) of the cavities themselves. The ferromagnetic metal chips (D) are welded to the springs, onto which the black thin plates (E1) and (E2) so shaped as to reproduce the corresponding digital characters (or numeral part) (A1)-(A7), are in turn fixed.

The functioning of the back-lighted cipher-indicator for price-lists of the present invention is evident from the drawings of the enclosed figures and the above description. The serigraphed transparent sheet (A) is joined to the flat support containing the stop-springs, the ferromagnetic chips and the black thin plates assembled as shown in Figures 3 and 4. The sheet can be glued to the flat support or fixed with shelf-threading screws.

With the situation illustrated in the drawings, after attaching the transparent sheet to the support, the black thin plates E1 are covered by the serigraphed part and therefore the figures (A1), (A3), (A6) and (A7) are visible whereas the black plates (E2), coinciding with the figures (A2), (A4) and (A5) cover these and they are therefore not visible.

To vary the situation, it is possible to move the black thin plates by manually shifting the metal chips with a permanent magnet. With this operation it is possible to form any number from zero to nine.

Claims

1. A numbering indicator comprising:

(a) a transparent sheet with opaque areas and seven transparent areas, the transparent areas representing the seven parts of the numeral "8";

(b) a flat support for the transparent sheet comprising seven cavities each positioned to correspond with one part of the numeral;

(c) seven opaque plates each associated with one of said transparent areas and moveable between a first position in which in which they obscure the respective transparent areas and a second position in which the respective transparent areas are unobscured;

(d) magnetic means associated with each of the seven opaque plates for enabling the plates to be moved between their first and second positions; and

(e) over centre means mounted in the cavities and connected to each of the seven opaque plates for biasing the plates towards one or other of their two positions.

2. A number indicator as claimed in claim 1, wherein the magnetic means comprise a metal chip made of ferromagnetic material attached to the associated plate.

3. A number indicator as claimed in claim 2, wherein the seven cavities are elliptical and the over centre means comprises a stop-spring centrally welded to each metal chip and, at the ends, to the apices of each elliptical cavity.

4. A number indicator as claimed in claim 3, wherein the stop-springs, when not assembled, have a length greater than the length of the major axis of the elliptical cavity and less than its semiperimeter.

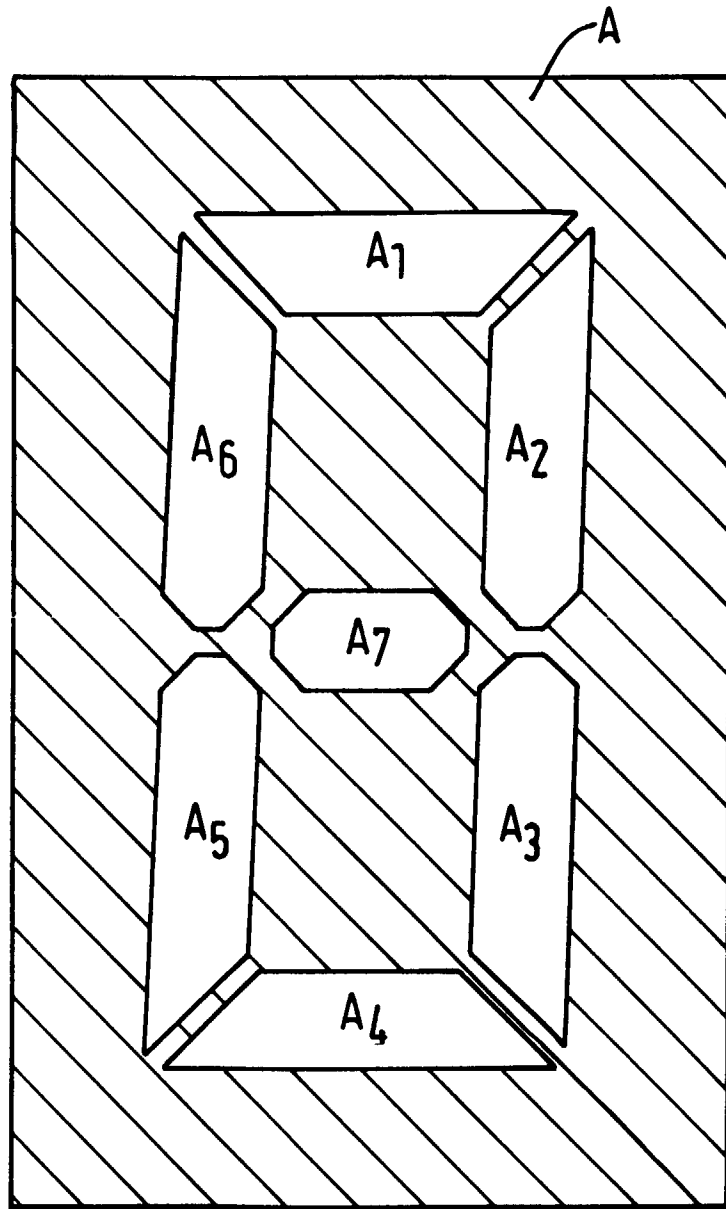

FIG. 1

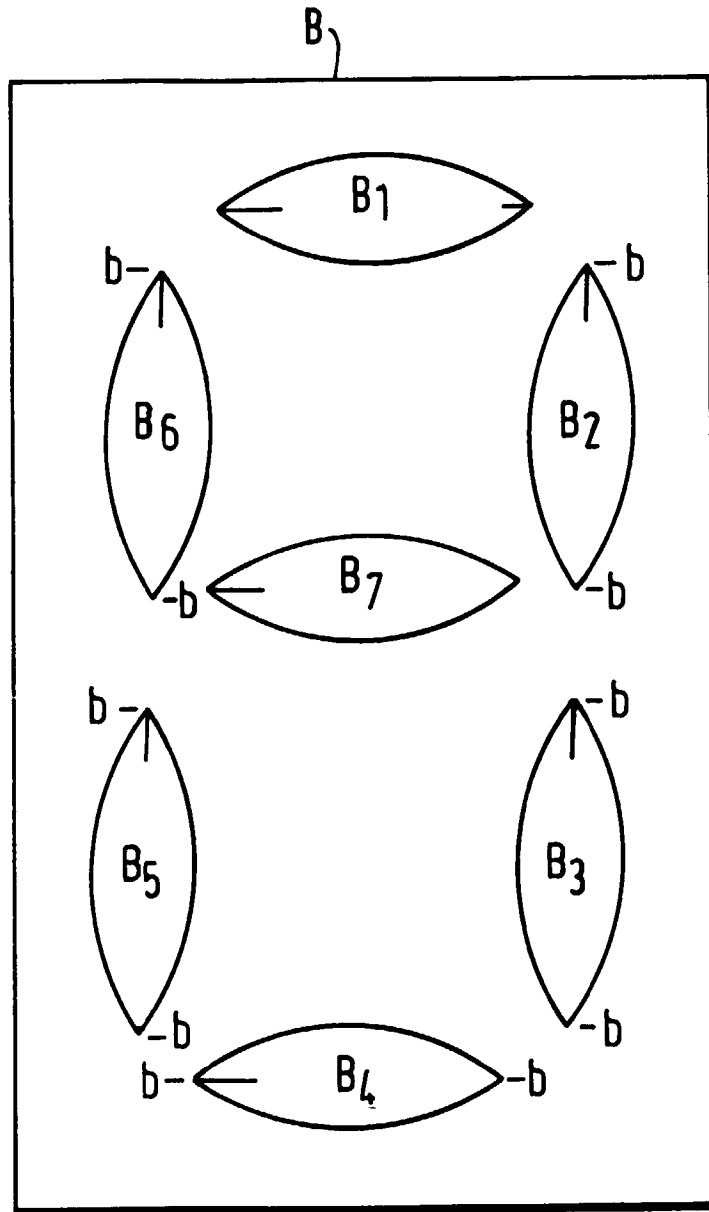

FIG. 2

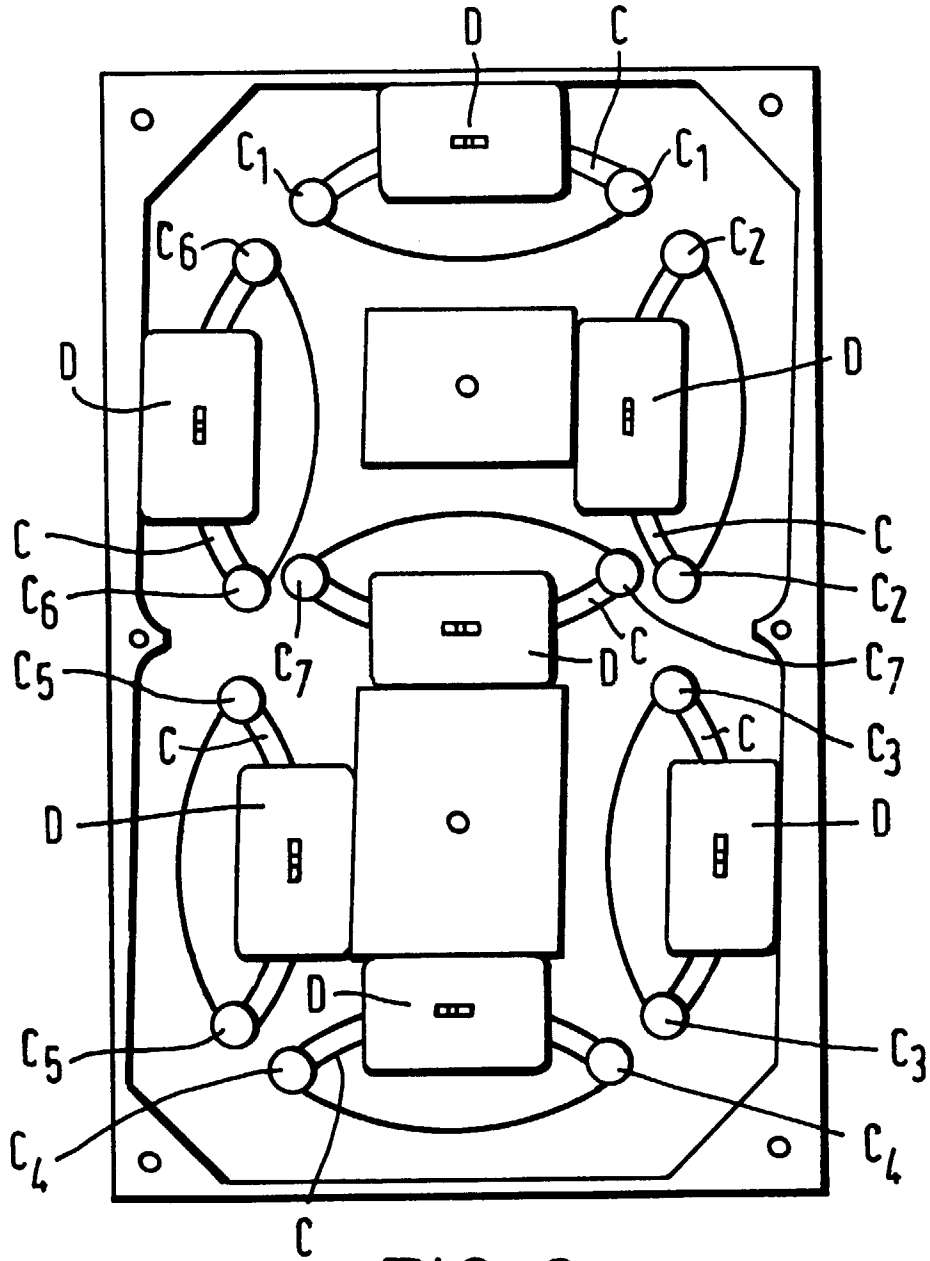

FIG. 3

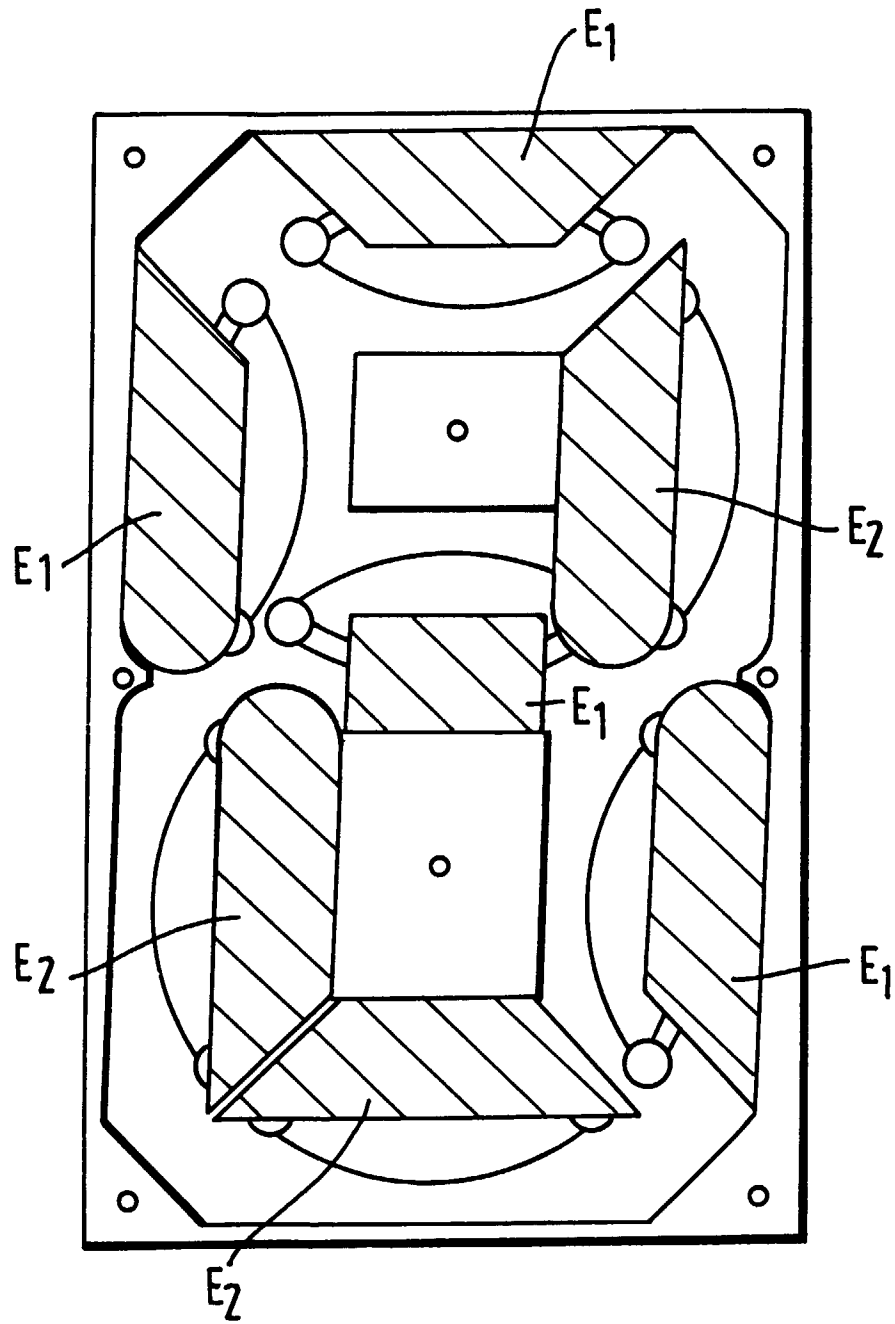

FIG. 4



European Patent
Office

EUROPEAN SEARCH REPORT

Application Number
EP 97 30 3521

DOCUMENTS CONSIDERED TO BE RELEVANT			
Category	Citation of document with indication, where appropriate, of relevant passages	Relevant to claim	CLASSIFICATION OF THE APPLICATION (Int.Cl.6)
A	US 4 161 832 A (G. BERGAMINI) * abstract; figures 1-3 * ---	1	G09F9/37
A	FR 2 640 790 A (L'ENTREPRISE INDUSTRIELLE) * abstract * -----	1	
The present search report has been drawn up for all claims			TECHNICAL FIELDS SEARCHED (Int.Cl.6)
			G09F
Place of search	Date of completion of the search	Examiner	
THE HAGUE	5 September 1997	Sgura, S	
<p>CATEGORY OF CITED DOCUMENTS</p> <p>X : particularly relevant if taken alone Y : particularly relevant if combined with another document of the same category A : technological background O : non-written disclosure P : intermediate document</p> <p>T : theory or principle underlying the invention E : earlier patent document, but published on, or after the filing date D : document cited in the application L : document cited for other reasons & : member of the same patent family, corresponding document</p>			

EPO FORM 1503 01/92 (P04C01)