

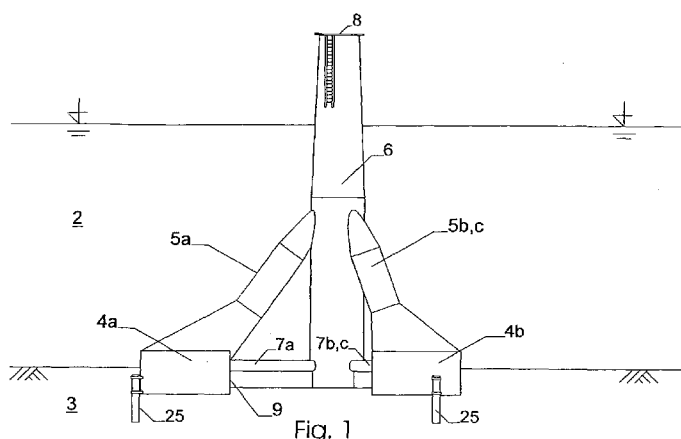

- (51) **International Patent Classification:**
E02B 17/02 (2006.01)
- (21) **International Application Number:**
PCT/NO2010/000212
- (22) **International Filing Date:**
8 June 2010 (08.06.2010)
- (25) **Filing Language:** English
- (26) **Publication Language:** English
- (30) **Priority Data:**
20092237 10 June 2009 (10.06.2009) NO
- (71) **Applicant (for all designated States except US):** SEATOWER AS [NO/NO]; Kirkeveien 64A, N-0364 Oslo (NO).
- (71) **Applicant (for US only):** KARAL, Eva (heiress of the deceased inventor) [NO/NO]; Rugdevn. 11, N-0778 Oslo (NO).
- (72) **Inventor:** KARAL, Karel (deceased).
- (72) **Inventor; and**
- (75) **Inventor/Applicant (for US only):** RAMSLIE, Sigurd [NO/AU]; 24 Sirius Ramble, Quinns Rocks WA 6030 (AU).
- (74) **Agents:** ONSAGERS AS et al.; P.O. Box 6963, St. Olavs plass, N-0130 Oslo (NO).
- (81) **Designated States (unless otherwise indicated, for every kind of national protection available):** AE, AG, AL, AM, AO, AT, AU, AZ, BA, BB, BG, BH, BR, BW, BY, BZ, CA, CH, CL, CN, CO, CR, CU, CZ, DE, DK, DM, DO, DZ, EC, EE, EG, ES, FI, GB, GD, GE, GH, GM, GT, HN, HR, HU, ID, IL, IN, IS, JP, KE, KG, KM, KN, KP, KR, KZ, LA, LC, LK, LR, LS, LT, LU, LY, MA, MD, ME, MG, MK, MN, MW, MX, MY, MZ, NA, NG, NI, NO, NZ, OM, PE, PG, PH, PL, PT, RO, RS, RU, SC, SD, SE, SG, SK, SL, SM, ST, SV, SY, TH, TJ, TM, TN, TR, TT, TZ, UA, UG, US, UZ, VC, VN, ZA, ZM, ZW.
- (84) **Designated States (unless otherwise indicated, for every kind of regional protection available):** ARIPO (BW, GH, GM, KE, LR, LS, MW, MZ, NA, SD, SL, SZ, TZ, UG, ZM, ZW), Eurasian (AM, AZ, BY, KG, KZ, MD, RU, TJ, TM), European (AL, AT, BE, BG, CH, CY, CZ, DE, DK, EE, ES, FI, FR, GB, GR, HR, HU, IE, IS, IT, LT, LU, LV, MC, MK, MT, NL, NO, PL, PT, RO, SE, SI, SK, SM, TR), OAPI (BF, BJ, CF, CG, CI, CM, GA, GN, GQ, GW, ML, MR, NE, SN, TD, TG).
- Published:**
— without international search report and to be republished upon receipt of that report (Rule 48.2(g))

(54) **Title:** TRIPOD FOUNDATION



(57) **Abstract:** An arrangement (1) for placement on a seabed (3) below a body of water (2), for support of a device for the production of electric power from wind, comprises a column (6; 6') having a first end provided with connecting means (8) that project above the body of water when the arrangement is installed on the seabed. At a portion that is below the surface of the body of water when the arrangement is installed on the seabed, the column is connected to three legs (5a-c), the legs at a second end being connected to respective foundations (4a-c) designed for installation on and transfer of forces to the seabed. Each foundation comprises a compartment (11) defined by a plate member (10) which at its periphery is connected to a skirt (9) that extends downwards from the plate element when the foundation is installed on the seabed, such that a substantially closed space (H') is formed in the compartment. Furthermore, each foundation (4a-c) comprises a ballasting compartment (12) defined by a lower plate member (10) which at its periphery is connected to a portion (13) of the respective leg (5a-c) and an upper partition (29) in the respective leg, and provided with means (27) for the supply of ballast liquid.

WO 2010/143967 A2

TRIPOD FOUNDATION

The invention relates to a support for a wind turbine or the like, for placement on a seabed, as disclosed in the preamble of the attached independent claims.

Background for the invention

5 The invention relates to a support structure for offshore windmills. The structures of this type that are found in the industry are intended only for use as the lowermost part of the support, the upper part being a separate structure that is mounted on the lower part in the field, that is to say, in the open sea. Apart from this limitation, these known structures have a number of drawbacks associated with two main
10 factors:

1. Foundation work with the use of piles that are installed in a separate operation, with small position tolerances;
2. Manufacture, transport and installation where structures without foundations are mounted and stored ashore, lifted and loaded onto vessels (barges), lifted off the
15 barges in the field and placed on pre-installed foundations, which typically are driven-in piles, and finally secured to these piles.

The disadvantages of this known solution are a number of weather-sensitive operations offshore, the use of heavy and costly crane vessels for both loading and unloading, a difficult method for obtaining verticality of the installed structure and
20 the need for very large land areas in docks for storage of completed structures in periods when it is not possible to carry out transport and installation with a reasonable weather window, i.e., winter and parts of autumn and spring.

Summary of the invention

The invention seeks to eliminate or reduce all the aforementioned disadvantages by
25 means of an arrangement for placement on a seabed below a body of water, for support of a device for the production of electric power from wind, comprising a column having a first end equipped with connecting means that project above the body of water when the arrangement is installed on the seabed, characterised in that the column, at a portion located below the surface of the body of water when the
30 arrangement is installed on the seabed, is connected to three legs, the legs at a second end being connected to respective foundations designed for installation on and transfer of forces to the seabed.

In one embodiment, respective connecting pieces are connected to the respective foundation at a first end and a lower portion of the column at a second end.

35 In one embodiment, there are respective connecting pieces between each of the foundations, such that the foundations and the connecting pieces form a triangle, the connecting pieces constituting the sides of the triangle.

Each foundation preferably comprises a compartment defined by a plate member which at its periphery is connected to a skirt that extends downwards from the plate member when the foundation is installed on the seabed, such that a substantially closed space is formed in the compartment.

- 5 In one embodiment each foundation comprises at least one damping device which is movable from a position in which it is on a level with the foundation to a position in which the damping device projects below the lower end of the foundation when the structure is in a normal state in the body of water or on the seabed.

10 Each foundation preferably comprises a ballasting compartment defined by a lower plate member which at its periphery is connected to a portion of the respective leg and an upper partition in the respective leg, and provided with means for the supply of ballast liquid.

15 A portion of the column, in one embodiment, comprises a ballast space which has a larger volume than the respective ballasting compartments and is provided with means for the supply of ballast liquid, and each leg is provided with an upper ballast space.

The arrangement is equipped with means for the supply of ballast liquid to the upper ballast space from said ballast space in the column.

20 In one embodiment, the legs are inclined in relation to the column, and connected to the column with equal angular spacing about the longitudinal axis of the column, preferably 120°.

A method is also provided for installation of an arrangement according to the invention on a seabed, characterised by the following steps:

- 25 a) filling the ballasting compartment and the ballast space in the column with ballast water in order to lower the arrangement towards the seabed;
- b) causing the skirt on each of the foundations to penetrate at least partially into the seabed, whereby the space in the compartment is at least partly filled with water;
- 30 c) selectively and individually applying a downward force on each of the foundations in order to drive the respective skirt of the foundations further into the seabed;
- until the desired depth of penetration and/or inclination has been reached.

In one embodiment, step c) is carried out by a selective pumping or selective discharge of water from the respective spaces.

35 Damping devices can be lowered to a level below the bottom end of the foundations prior to or simultaneously with step a).

In one embodiment, the respective upper ballast spaces are filled with ballast water after step a) and prior to step b).

The support is configured as a structure with three legs, where each of the legs is terminated in a foundation which transfers load from the structure into the seabed.

5 The invention has a number of advantages over the prior art, e.g.:

- The whole structure can be built and fitted out (also with turbines, rotor blades, cables) at an assembly site in sheltered waters, thereby significantly reducing or even eliminating work in open waters with heavy crane vessels.
- 10 • The structure is assembled from prefabricated segments whilst they float moored to a wharf or quay and the work can be done by substantially smaller cranes than the known structures require for unloading structures assembled onshore;
- The foundations are incorporated into the rest of the structure which eliminates the need for stabilisation measures during pile driving in open
15 waters, the driving in of piles and the securing of the structure to the driven-in piles;
- The structure is towed to the installation field and lowered to the seabed using seawater that is admitted into ballast compartments which eliminates the need for crane ships and substantially reduces the weather risk and
20 waiting for weather

Brief description of the figures

These and other characteristics of the invention will become clear from the following description of preferred embodiments, given as non-limiting examples and with reference to the appended figures in which like reference numerals
25 indicate like parts, and wherein

Fig. 1 is a side view of a first embodiment of the structure according to the invention, positioned on a seabed;

Fig. 2 is a top view of the structure shown in Fig. 1;

30 Fig. 3 is a sectional view of a lower portion of the structure according to the invention taken along the line A-A indicated in Fig. 2;

Fig. 4 is a side view of a second embodiment of the structure according to the invention, positioned on a seabed;

Fig. 5 is a top view of the structure in Fig. 4;

35 Figs. 6-9 are side views showing an assembly sequence for the structure according to the invention;

Fig. 10 is a side view showing a temporary anchoring configuration for a plurality of structures;

Fig. 11 and Fig. 12 are side views showing two steps of the installation of the structure on a seabed;

5 Figs. 13-15 are side views through a lower part of one embodiment of the structure according to the invention; and

Fig. 16 is a side view showing the second embodiment of the structure according to the invention, positioned on a seabed.

Detailed description of an embodiment of the invention

10 The arrangement according to the invention is first described in connection with a structural design which satisfies today's requirements and contract splitting of the work between the contractors (i.e., the lower part of the structure comprising the foundations, the stiffening structure and the lower part of the actual tower which, when installed, projects above the surface of the water). The design of the whole
15 support is then described together with associated transport and installation means.

Fig. 1 is a view of an embodiment of the structure 1 according to the invention installed in water 2 and resting on a seabed 3. The structure comprises, in this embodiment, three foundations 4a-c and three inclined legs 5a-c connecting the respective foundations 4a-c to respective portions of a column 6. In the horizontal
20 plane, the foundations 4a-c are connected to the column 6 via respective struts 7a-c, for example, tubular struts. The column 6, which projects up from the foundations and extends above the surface of the water when the structure is installed on the seabed, is provided at the top with a device 8 for mounting of the rest of the tower (not shown), e.g., a flange. When the structure 1 has been installed in the field, the
25 tower itself can be mounted to the flange, and then a generator with nacelle and rotor can be mounted.

To retard and essentially stop wave-induced motions during the lowering onto the seabed 3, each foundation 4a-c is equipped with respective dowels 25. During
30 installation, the dowels will be the elements on the structure which come into contact with the seabed first and will exert resistance against the horizontal and vertical motions of the foundation. The dowels are sized appropriately for the structure in question such that the motions of the structure are damped to an acceptable level when the respective skirts 9 of the foundations (described below) come into contact with the seabed. In Fig.1 the dowels 25 are shown in an
35 installation position, where the dowels project substantially below the skirt 9. For towing in shallow waters it may be desirable or essential that the dowels should be capable of assuming a position in which they do not project deeper than the skirt 9 itself, e.g., as shown in Fig. 10.

Fig. 2 is a top view of the structure 1 illustrated in Fig. 1, and shows, inter alia, that the legs 5a-c and the foundations 4a-c in this embodiment are symmetrically distributed around the column 6.

5 Fig.3 shows a vertical section through the lower part of the whole structure along a plane A-A defined in Fig. 2. The structure is shown installed on a seabed 3. This figure shows one of the foundations 4a and the associated tubular strut 7a fastened to a lower part of the column 6, and also a part of the associated leg 5a.

10 Each of the foundations 4a-c is configured with a compartment 11 which is open towards the seabed and surrounded by a vertical plate (also called "skirt") 9, and closed at the top by foundation plate 10. This part of the foundation is thus in principle designed as an inverted cup – a design that is used, inter alia, in suction anchors. It may be advantageous to use concrete in the foundation plate 10 as ballast and also as a supporting structural element. The weight of the concrete lowers the centre of gravity of the structure, which is important in order to achieve
15 desired floating stability during the lowering to the seabed, as explained in more detail with reference to Fig. 6.

20 As shown in Fig. 3, a part of the compartment 11 that is defined by the skirt 9 and the foundation plate 10, in an installation state, will be partially penetrated into the seabed 3. Above the seabed, in this state, a space 11' is formed which, during the installation process, is filled with a filler material, such as a concrete mixture known as grout. By injecting grout into the space 11' adequate contact is obtained between the underside of the foundation plate 10 and the (often uneven) seabed 3, and good anchoring of the foundation 4a-c is established once the grout has
25 hardened. It is therefore not necessary to level the seabed before the actual installation.

Above the foundation plate 10 there is provided a ballasting compartment 12, as shown in Fig. 3, delimited on the side by a circular wall 12' and at the top of the actual leg 5a by its lower extension 13. The size of the ballasting compartment 12 and its upward extent in the leg 5a-c is an important structural parameter which
30 controls the floating stability of the structure. This is described in more detail with reference to Fig. 13.

To increase the geotechnical bearing capacity of the structure, the struts 7a-c can be equipped with longitudinal skirts 14 as shown in Fig. 3.

35 Fig. 4 shows a second embodiment of the structure 1' where a column 6' is terminated in the area in which the legs are fastened to the column 6' itself. In this embodiment, tubular struts 7'a-c connect the foundations 4a-c. In this embodiment too, the struts 7'a-c may be equipped with longitudinal skirts 14.

Each foundation 4a-c can advantageously – in both embodiments – be equipped with guide tubes 40 for feed-through of a respective pile 42 that is driven into the

seabed (shown in Fig. 17). Such piles 42 that are passed through and then secured to the guide tubes 40 may be necessary in weak bottom masses to strengthen the load bearing capacity of the structure in both this and the preceding embodiment described with reference to Figs. 1 and 2. If the depth along the tow route so
5 allows, the foundations 4a-c may also be equipped with extended guide tubes 41, which project below the skirt 9 and thus serve to stabilise the structure during the lowering thereof onto the seabed, in the same way as the dowels 25 described above with reference to Figs. 1 and 2.

The embodiment described with reference to Fig. 4 is further illustrated in Fig. 5, which is a top view of the structure. The tubular struts 7'a-c join the foundations
10 4a-c together. The legs 5a-c are terminated at the top against the column 6'. Preferred locations of the guide tubes 40 and the extended guide tubes 41 are shown. Although it is not shown in Fig. 4 or 5, a person of skill in the art will understand that this embodiment, too, can be equipped with dowels 25 of the type
15 described above.

Fig. 6 to Fig. 13 show main phases in the assembly, towing and installation of the structure according to the invention. The assembly is carried out starting from structural elements, or large structural segments prefabricated in a specialised workshop in the assembly area or another location. The splitting into elements and
20 segments is determined by the optimisation of the process with the aim of obtaining lowest costs at the desired production rate. The assembly area may advantageously be in the vicinity of the offshore installation site and should satisfy requirements as to infrastructure, equipment (cranes, concrete mixers), size (a substantially smaller area is required than when using existing solutions), and as to the marine conditions
25 such as water depth for towing into open sea and environmental conditions. Available capacity for cranes and unloading method determines the size of the sections used for the actual assembly.

Fig. 6 shows a first section 43 of the structure that was assembled on shore or on a barge, float or the like before it was launched into the body of water 2. The first
30 section 43 is moored to a wharf or quay 15, e.g., by means of a mooring 16. The foundation 4a is shown in section, the basis for the foundation plate 10 is shown. In this embodiment the plate 10 is of steel and is dimensioned to withstand the pressure of the water that holds the sections afloat during the assembly process, which is substantially smaller than loads applied in other states, e.g., during
35 installation. The actual strength of the foundation plate for taking up loads throughout the rest of the assembly, transport, installation and operation is obtained using concrete that should be cast after prefabricated reinforcement netting 17 has been installed.

Fig. 7 shows a second section 19 that is lowered onto the structure for connection to
40 the first section 14.

Fig. 8 shows a third section 20 that is lowered onto the structure for connection to the second section 19.

Fig. 9 shows a fourth section 18 that is lifted and in the next phase lowered onto the structure for connection to the third section 20.

5 After this assembly process has been carried out the whole foundation 1 can be moved out to a storage site or directly to the installation site. Fig. 10 shows a plurality of foundations 1 that have been connected by tow lines 22 to mooring buoys 21. These are anchored to the seabed by anchor lines 23 and anchors 24.

10 Fig. 11 shows foundation 1 after it has been towed to the installation site by towboats (not shown). The dowels 25 have been released from a transport position to take up a position in which they project below the skirts 9. The ballast water intakes have been opened (described below with reference to Fig. 13) and the foundation sinks down towards the seabed 1. At a distance of about 1 – 3 metres above the seabed, measured from the lower end of the dowels, the ballasting is interrupted and the foundation is manoeuvred into an installation position after
15 which intake of ballast water is started again. The weight of the ballast water lowers the foundation until the dowels 25 come into contact with the seabed (after which the movements are slowed down as described above) and then the skirts 9 come into contact with the seabed and they penetrate to a depth at which the
20 penetration stops because the submerged weight of the foundation is equal to the resistance from the seabed against further penetration of the skirt 9.

Fig. 12 shows the foundation after the aforementioned equilibrium situation has been reached. Further penetration is achieved by pumping water out of the skirt compartments as explained in more detail in the description of Fig. 13.

25 Fig. 13 is a schematic view of equipment for lowering with the aid of ballasting with seawater. The figure indicates a section through the foundation 4a, the leg 5a and the column 6 after the structure has been lowered using ballast water in the ballasting compartment 12 and inside a compartment in a lower portion of the column 6 where the water surface is indicated by reference numeral 26. The
30 relative height between the water surface 26 and the surface W of the sea 2 gives a pressure gradient that forces ballast water into the structure through pipes fitted with valves 27. By adjusting the respective valve 27 for each of the foundations 4a-c, a water stream can be passed in a controlled manner into the respective ballasting compartments 12 in each foundation 4a-c.

35 The ballasting equipment further comprises a pipe fitted with a valve 28 which passes water into the column 6. The valves may advantageously be collected on a panel and controlled by a remote-controlled subsea vessel, or by a specially designed operating module. The inclination of the structure is measured throughout the installation and in the lowering phase and is corrected as required by controlling

the water streams to the respective ballasting compartment 12 in each of the foundations 4a-c.

5 The size of the ballasting compartment 12 may be a parameter that determines the location of the centre of gravity in advanced phases of the lowering when the structure may be “excessively stable” with the consequence that the oscillation period in rolling motion can be reduced and can come close to wave periods. The consequence of this is an undesired increase of motions of the foundation. To avoid this, it may be advantageous to limit the size of the respective compartments 12 with respective partitions 29 as shown in Fig. 13. A ventilation pipe 30 ensures that
10 the air can escape from the compartments 12 as they are filled with water.

After the compartments 12, defined by the partitions 26, are filled with water, the ballasting water can only flow into the column 6. The amount of water in the column rises and the centre of gravity is elevated faster than if the ballasting in the legs had continued unimpeded. When the water level in the column reaches a high
15 level 31, a ballast space 33 in each leg 5a-c is also filled with ballast water through a pipe 32 whilst the air escapes through pipe 34. Should it be necessary to further increase the weight of the whole structure for stability during operation, the water in parts of the structure can – after installation has been completed – be replaced by sand and the like by pumping sand over the top of the structure into the column.

20 Fig. 14 is a schematic view of equipment for penetration for correction of horizontality during penetration of the skirts into the seabed, increase of vertical loads to obtain full penetration and for replacing enclosed water in the skirt spaces 11' with a liquid mass that sets over time. A section is shown through the column 6, the foundation 4a with circular skirt 9 and through tubular strut 7a with a plane
25 skirt 14 penetrated into the seabed 3 as a result of the submerged weight of the structure. The skirt compartments 11' are defined by the circular skirts 9, the seabed 3 and the foundation plate 10, as described above. The water that is enclosed within the skirt compartments 11' can escape through a valve 36, for example, an automatic valve, due to a pressure difference that is formed during penetration.

30 To cause the skirts to penetrate further, the structure has applied thereto a vertical, downward hydrostatic force which is produced in that the water enclosed within the skirt compartments 11' is pumped out through pipes 37a-c equipped with valves 38a-c. By individual control of the water pressure in the skirt compartments 11' in each of the foundations 4a-c, the structure can have applied thereto a moment which
35 forces the structure into a desired inclination or verticality with great precision.

Fig. 15 shows the situation after the desired penetration depth of the skirts 9, 14 and desired inclination/verticality has been obtained. Thus, the skirt compartments 11' have been given a height that is suitable for injection of the aforementioned grout and displacement of enclosed water. Grout 39 is pumped into the compartments 11'
40 in each foundation 4a-c through pipes 37a-c and the water escapes through automatic

valves 36. After the water has been forced out, the valves 38a-c are closed to prevent escape of the grout. The closing is based on grout having a greater density than seawater. Injection of grout can be carried out as a separate operation with another weather window.

- 5 The work described above with reference to Fig. 15 terminates the installation. Depending in local conditions, it may, as mentioned above, be necessary to replace the ballast water in the structure with heavier, solid ballast (sand) and/or install erosion protection around the foundations 4a-c.

- 10 The method for penetration and inclination correction and injection of grout in a separate operation described with reference to Fig. 14 is suitable for structures installed on a seabed with masses of low permeability such as clay, silt, dense moraine masses or the like. In masses with high permeability, a predetermined amount of grout is injected into the skirt compartments 11' before the pumping through pipes 37a-c is initiated.

- 15 Fig. 16 illustrates the structure 1 placed on a seabed 3, penetrated to a desired depth and levelled. A pile 42 inserted into a guide tube 41 has been made ready to be driven into the seabed. After the driving in has been carried out, the pile 42 can be secured to the guide tube 41 in a known way, for example, by means of grouting or plastic deformation.

PATENT CLAIMS

1. An arrangement (1) for placement on a seabed (3) below a body of water (2), for support of a device for the production of electric power from wind, comprising a column (6; 6') having a first end equipped with connecting means (8) that project
5 above the body of water when the arrangement is installed on the seabed, **characterised in** that the column (6; 6'), at a portion that is below the surface of the body of water when the arrangement is installed on the seabed, is connected to three legs (5a-c), the legs at a second end being connected to respective foundations (4a-c) designed for installation on and transfer of forces to the seabed.
- 10 2. An arrangement according to claim 1, characterised in that respective connecting pieces (7a-c) are connected to the respective foundation (4a-c) at a first end and a lower portion of the column (6) at a second end.
3. An arrangement according to claim 1, characterised by respective connecting
15 pieces (7a'-c') between each of the foundations (4a-c), such that the foundations and the connecting pieces form a triangle, the connecting pieces constituting the sides of the triangle.
4. An arrangement according to any one of the preceding claims, characterised
20 in that each foundation (4a-c) comprises a compartment (11) defined by a plate member (10) which at its periphery is connected to a skirt (9) that extends downwards from the plate member when the foundation is installed on the seabed such that a substantially closed space (11') is formed in the compartment.
5. An arrangement according to any one of the preceding claims, characterised
25 in that each foundation (4a-c) comprises at least one damping device (25), which is movable from a position in which it is on a level with the foundation to a position in which the damping device (25) projects below the lower edge of the foundation, when the structure is in a normal state in the body of water or on the seabed.
6. An arrangement according to any one of the preceding claims, characterised
30 in that each foundation (4a-c) comprises a ballasting compartment (12) defined by a lower plate member (10) which at its periphery is connected to a portion (13) of the respective leg (5a-c) and an upper partition (29) in the respective leg, and provided with means (27) for the supply of ballast liquid.
7. An arrangement according to claim 6, characterised in that a portion of the
35 column (6) comprises a ballast space which has a larger volume than the respective ballasting compartments and is provided with means (28) for the supply of ballast liquid, and that each leg (5a-c) is provided with an upper ballast space (33).

8. An arrangement according to claim 7, characterised by means (32) for the supply of ballast liquid to the upper ballast space (33) from said ballast space in the column (6).
9. An arrangement according to any one of the preceding claim, characterised in that the leg (5a-c) are inclined in relation to the column (6; 6') and connected to the column with equal angular spacing about the longitudinal axis of the column, preferably 120°.
10. A method for installation of an arrangement as disclosed in claims 1-9 on a seabed, **characterised by** the following steps:
- 10 a) filling the ballasting compartment (12) and the ballast space in the column (6) with ballast water in order to lower the arrangement towards the seabed;
- b) causing the skirt (9) on each of the foundations (4a-c) to penetrate at least partially into the seabed, whereby the space (11') in the compartment (11) is at least partly filled with water;
- 15 c) selectively and individually applying a downward force on each of the foundations in order to drive the respective skirts of the foundations further into the seabed;
until the desired penetration depth and/or inclination has been reached.
11. A method according to claim 10, characterised in that step c) is carried out by a selective pumping or selective discharge of water from the respective spaces (11').
12. A method according to claim 10, characterised in that damping devices (25) are lowered to a level below the bottom end of the foundations, prior to or simultaneously with step a).
- 25 13. A method according to any one of claims 10-12, characterised in that the respective upper ballast spaces (33) are filled with ballast water after step a) and prior to step b).
- 30

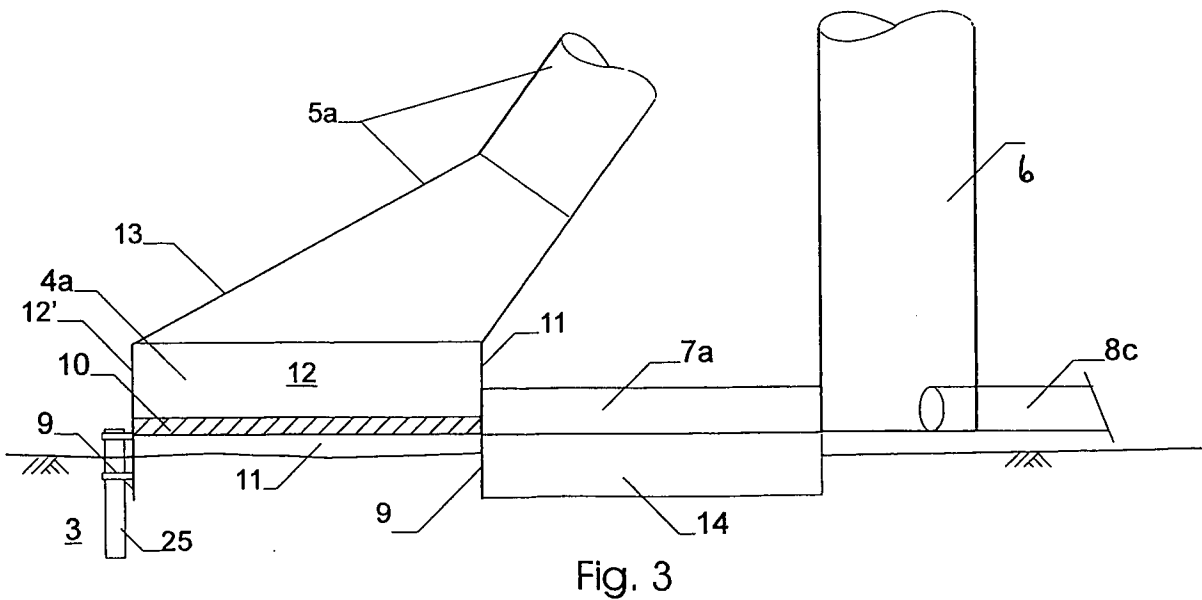
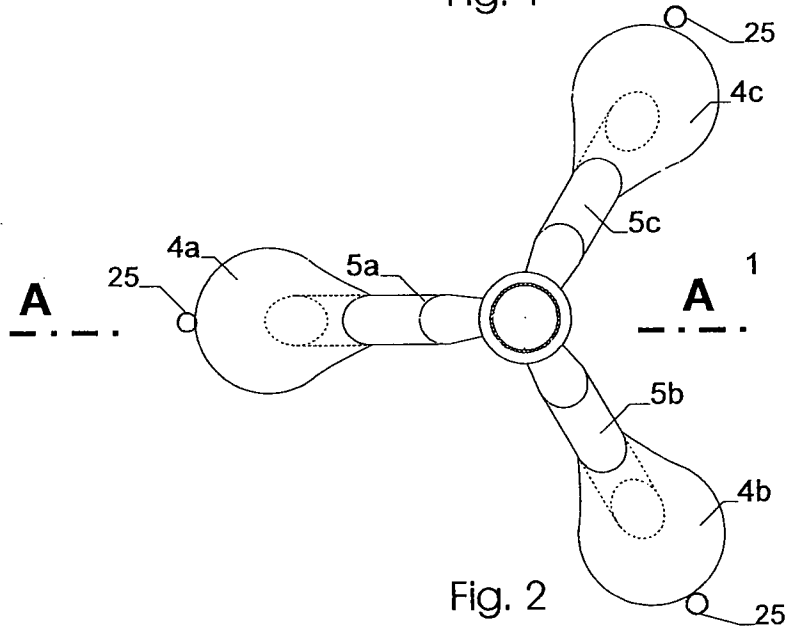
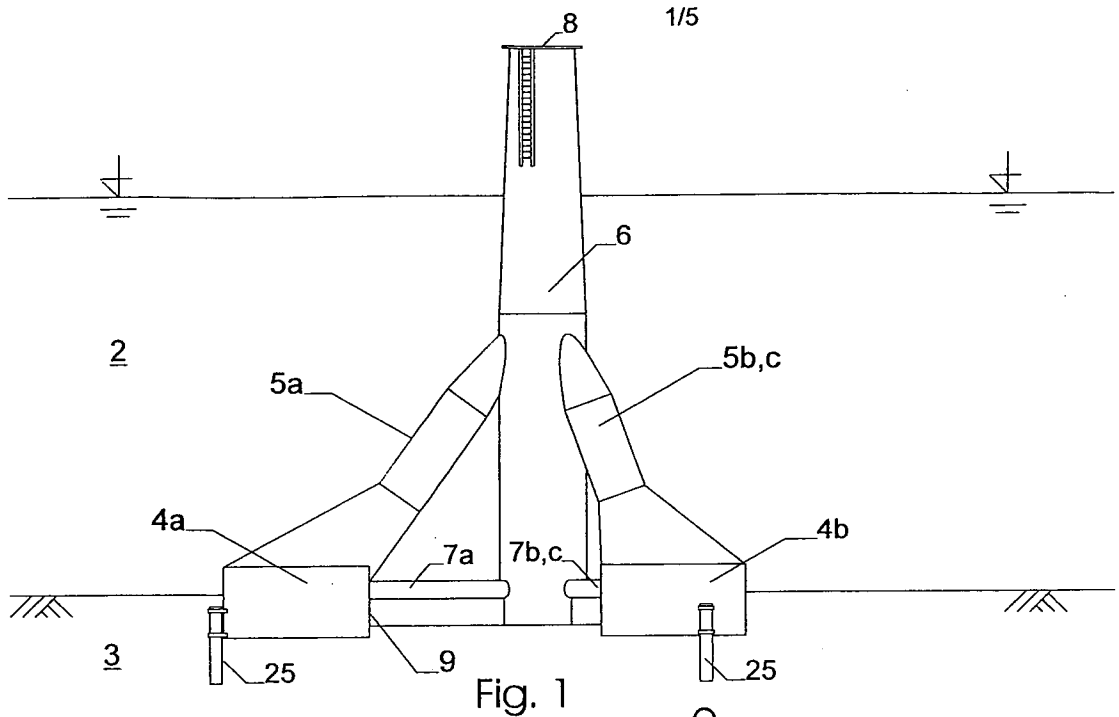

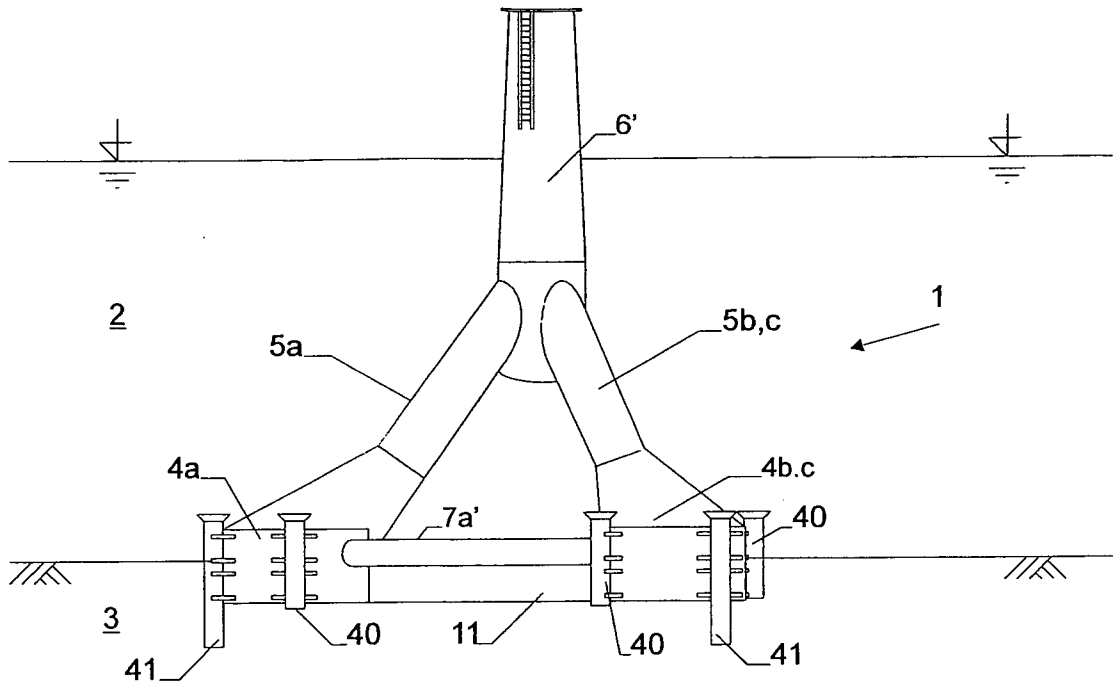

Fig. 4

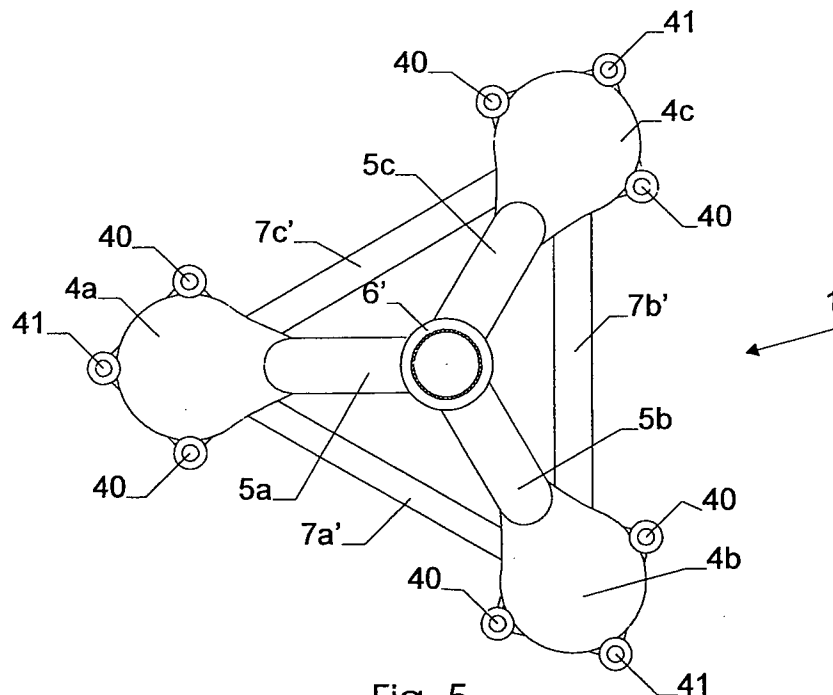

Fig. 5

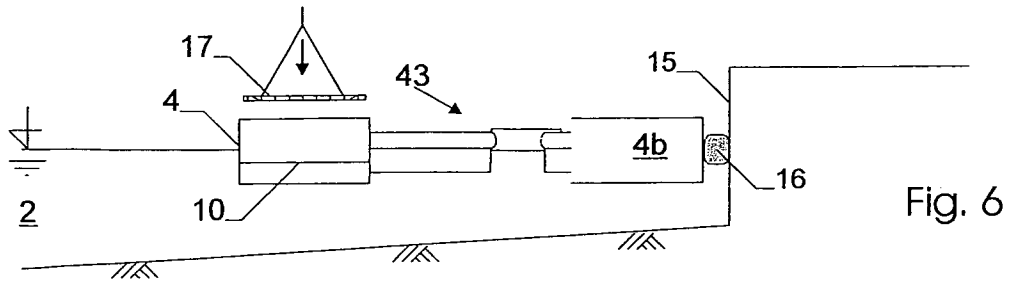

Fig. 6

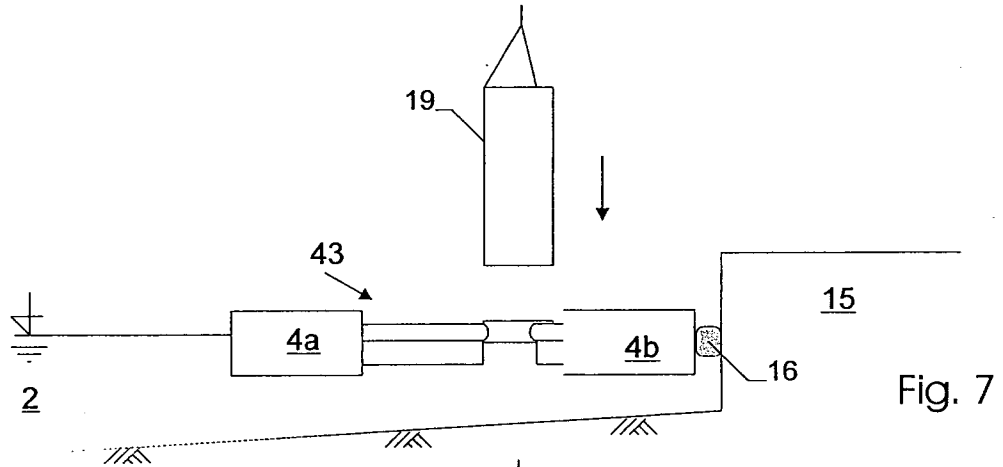

Fig. 7

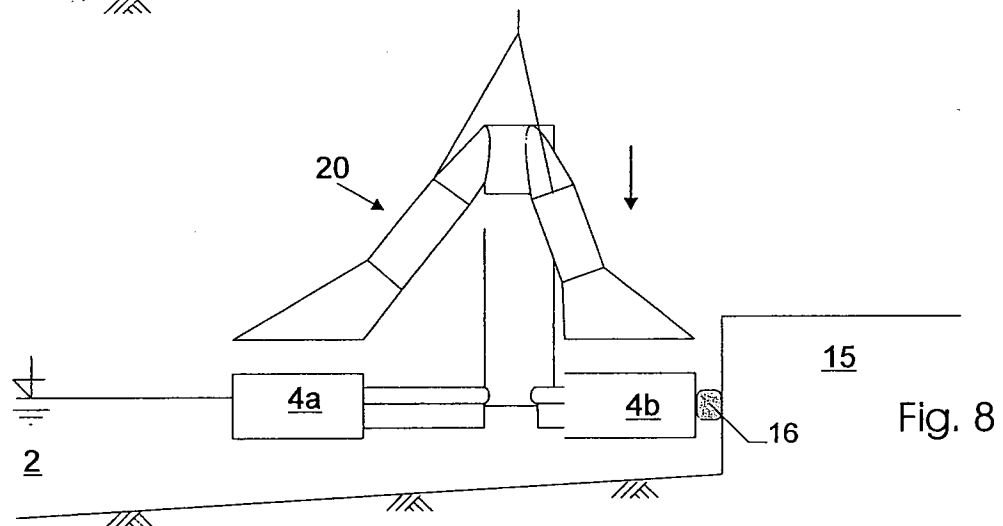

Fig. 8

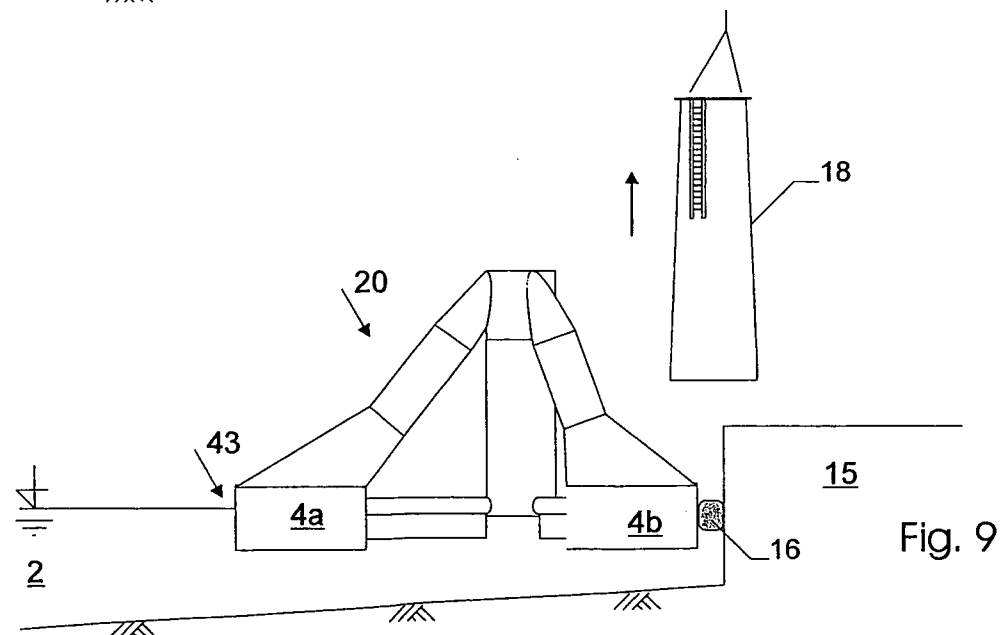

Fig. 9

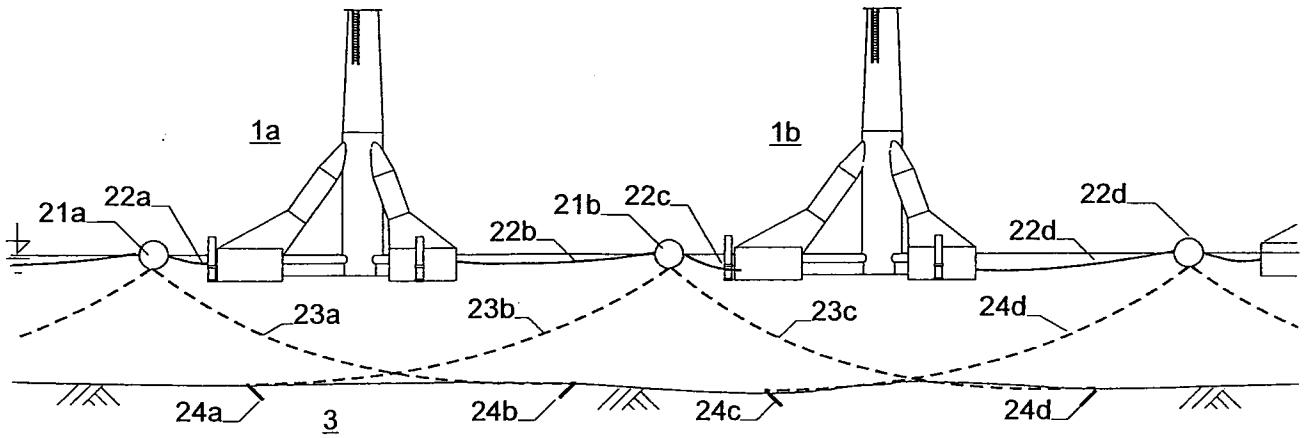

Fig. 10

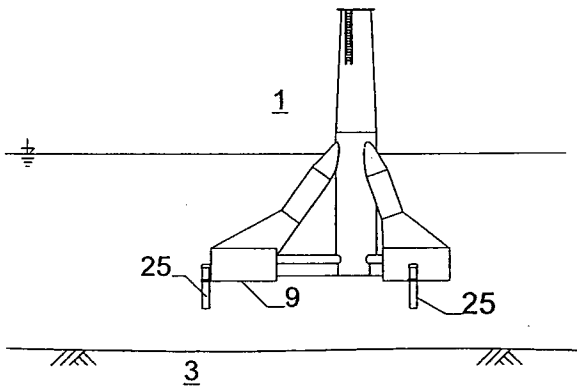

Fig. 11

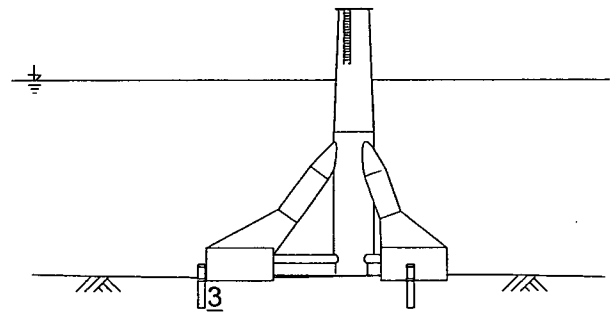

Fig. 12

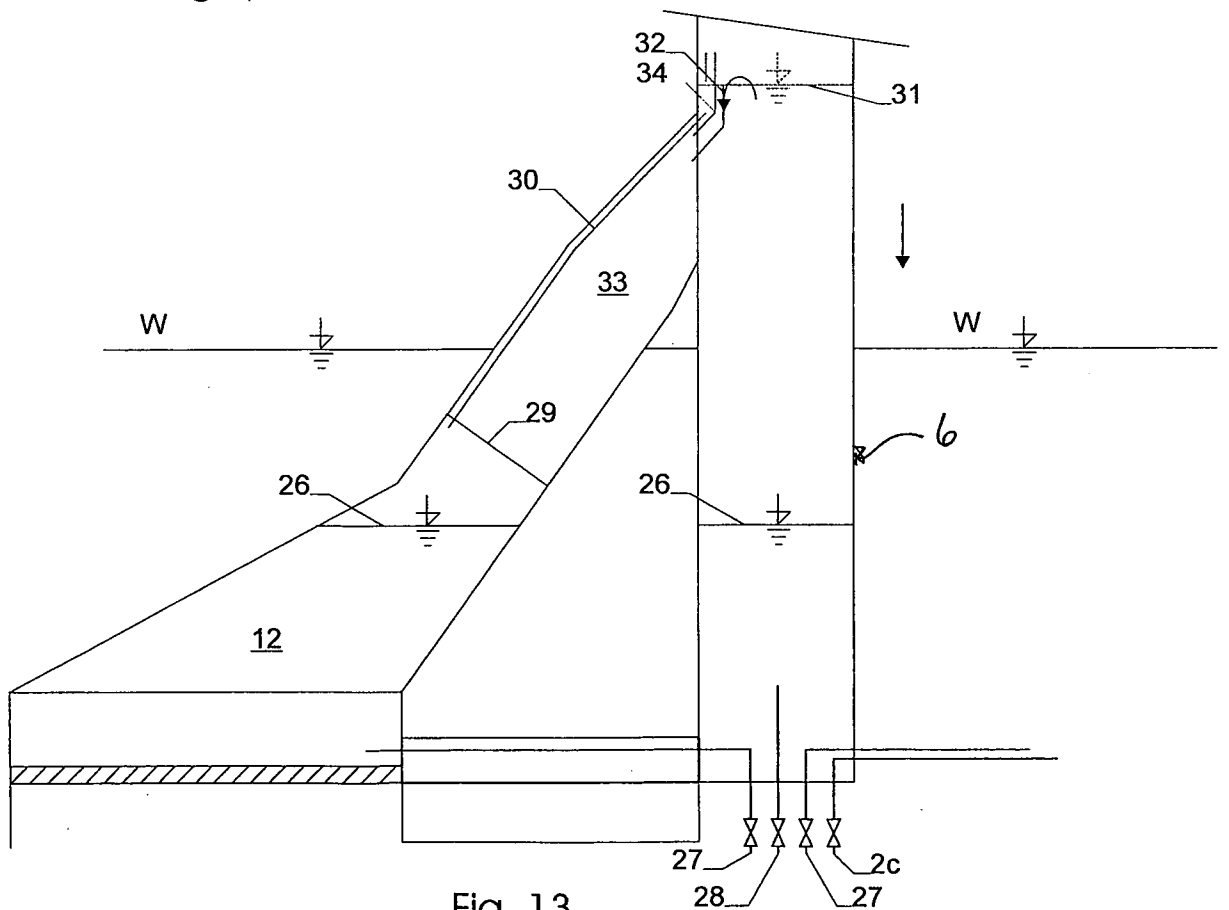

Fig. 13

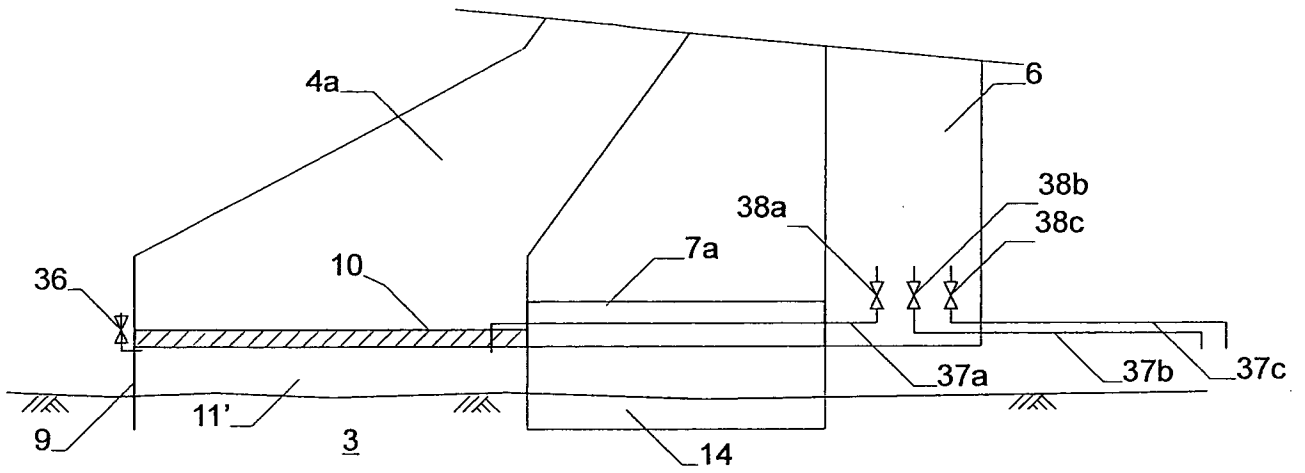

Fig. 14

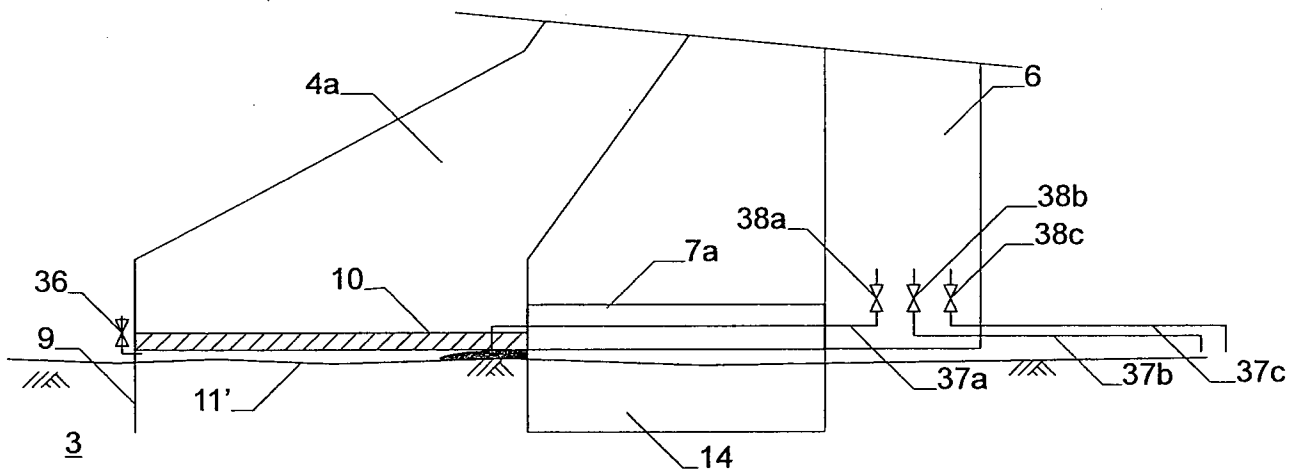

Fig. 15

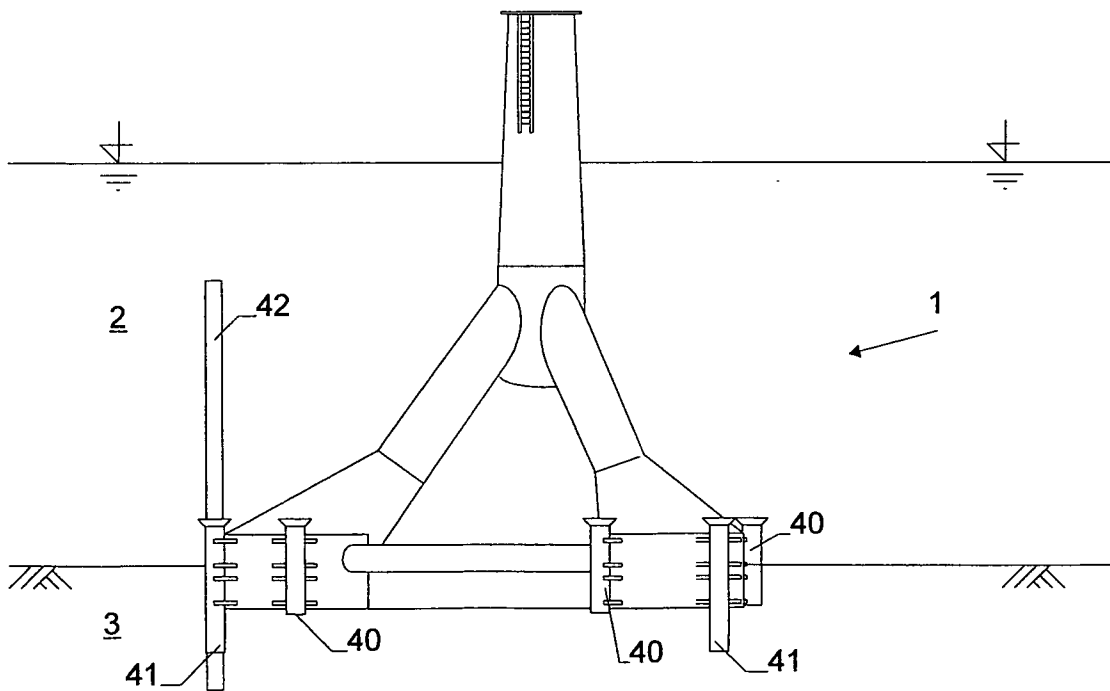

Fig. 16