



Europäisches Patentamt  
European Patent Office  
Office européen des brevets



(11) **EP 0 912 127 B1**

(12) **EUROPEAN PATENT SPECIFICATION**

(45) Date of publication and mention  
of the grant of the patent:

**06.11.2002 Bulletin 2002/45**

(21) Application number: **97932902.6**

(22) Date of filing: **14.07.1997**

(51) Int Cl.7: **A47K 3/28, F16K 11/072**

(86) International application number:  
**PCT/GB97/01903**

(87) International publication number:  
**WO 98/002077 (22.01.1998 Gazette 1998/03)**

(54) **SHOWER APPARATUS COMPRISING MULTIPLE SHOWER HEADS AND DIVERTER**

DUSCHVORRICHTUNG MIT MEHREREN DUSCHKÖPFEN UND UMSCHALTER

DISPOSITIF DE DOUCHE COMPRENANT DES TETES DE DOUCHE MULTIPLES ET UN  
DEVIATEUR

(84) Designated Contracting States:  
**AT BE CH DE DK ES FI FR GB GR IE IT LI LU MC  
NL PT SE**

(30) Priority: **13.07.1996 GB 9614776**

(43) Date of publication of application:  
**06.05.1999 Bulletin 1999/18**

(73) Proprietor: **DARYL INDUSTRIES LIMITED  
Merseyside L44 7HY (GB)**

(72) Inventor: **BERNSTEIN, Melville, Sydney  
Wallasey, Merseyside L44 7HY (GB)**

(74) Representative: **Thomson, Paul Anthony  
Potts, Kerr & Co.  
15, Hamilton Square  
Birkenhead Merseyside L41 6BR (GB)**

(56) References cited:  
**EP-A- 0 363 657                      EP-A- 0 446 862  
WO-A-87/07499                      GB-A- 2 274 985  
US-A- 5 121 511                      US-A- 5 329 650  
US-A- 5 561 869**

**EP 0 912 127 B1**

Note: Within nine months from the publication of the mention of the grant of the European patent, any person may give notice to the European Patent Office of opposition to the European patent granted. Notice of opposition shall be filed in a written reasoned statement. It shall not be deemed to have been filed until the opposition fee has been paid. (Art. 99(1) European Patent Convention).

## Description

**[0001]** The present invention relates to improvements in or relating to shower apparatus.

**[0002]** Conventional shower apparatus, usually housed in a shower enclosure or above a bath, generally include a shower head attached to one end of a conduit means. The other end of the conduit means is in communication with a mixing means which, in turn, is attached to a hot and cold water supply. The mixing means enables the hot and cold water to be mixed so that the water passing through the shower head, via the conduit means, onto the user, is of a desired temperature previously selected by the user. The major disadvantage of such conventional shower apparatus is that the user, in order to direct the flow of water onto various parts of his/her body, either has to move in relation to the shower head, or alternatively, has to remove the shower head from its associated holder and move the shower head around his/her body, whilst holding same.

**[0003]** US-A-5121511 discloses a shower apparatus comprising a plurality of shower heads each attached to respective conduit means, each of the conduit means also being in communication with a mixing means which is in communication with a hot and cold water supply, wherein diverter means are located between the mixing means and each of the conduit means for diverting water originating from the mixing means either to one shower head at a time, or alternatively, to more than one shower head at the same time.

**[0004]** It is an object of the present invention to provide a shower apparatus which at least minimises the disadvantages outlined above. In particular, the present invention provides a shower apparatus comprising a plurality of shower heads whereby water can be directed either solely through one of said shower heads onto the user, or alternatively, through more than one shower head at the same time onto the user, thereby providing a very flexible shower environment and experience, permitting the user to easily and quickly move the direction of the water hitting them, rather than having to move in relation to the shower heads or hold a flexible shower head and move it around their body.

**[0005]** According to the present invention there is provided a shower apparatus comprising a plurality of shower heads each attached to respective conduit means, each of the conduit means also being in communication with a mixing means which is in communication with a hot and cold water supply, in that diverter means being located between the mixing means and each of the conduit means for diverting water originating from the mixing means either to one shower head at a time, or alternatively, to more than one shower head at the same time characterised in that the diverter means comprises a valve means in the form of a ceramic disc diverter valve means comprising a valve housing, a first static disc having a plurality of apertures provided therein, a second rotating disc having a single aperture there-

in, the number of apertures in the first static disc corresponding to the number of shower heads utilised, the location of the apertures in such discs being so arranged and/or the shape of the discs being so designed, that, when the rotating disc is rotated it is possible to divert water either to one of the shower heads at a time, or alternatively, to more than one shower head at the same time, and operating means for operating the diverter valve means.

**[0006]** In a preferred embodiment, said shower apparatus is preferably in the form of a shower column, which column is preferably provided with four shower heads. In such case, the diverter means can divert water to each of said shower heads separately, or to more than one, preferably two, shower heads at the same time.

**[0007]** Preferably, the shower apparatus includes drainage means to reduce the risk of limescale build up in the shower heads. In a preferred embodiment, the drainage means is in the form of a linked recess on the surface of the rotating disc which connects the conduits that are not in use at the time, thereby enabling water to drain from one shower head to another and hence, clear all water through the lowest open shower head.

**[0008]** One embodiment of a shower apparatus of the present invention which comprises four shower heads and diverter means for diverting water originating from the mixing means to one shower head, or to two shower heads at the same time, will now be described by way of example and with reference to the accompanying drawings, in which:

Fig. 1A is a side view of one embodiment of a shower apparatus of the present invention;

Fig. 1B is a front view of the shower apparatus of Fig. 1A;

Fig. 2 illustrates a ceramic disc diverter valve;

Figs. 3A&B illustrate the water flow when the ceramic disc diverter valve is set to direct water to the upper shower head;

Figs. 4A&B illustrate the water flow when the ceramic disc diverter valve is set to direct water to the hand shower head;

Figs. 5A&B illustrates the water flow when the ceramic disc diverter valve is set to direct water to the mid-body shower head;

Figs. 6A&B illustrates the water flow when the ceramic disc diverter valve is set to direct water to the foot shower head; and

Figs. 7A&B illustrates the water flow when the ceramic disc diverter valve is set to direct water to the upper shower head as well as the mid-body shower

head.

**[0009]** With reference to Figs. 1A&B, a shower apparatus 10 comprises four shower heads directable to different parts of the body, namely, an upper shower head 11 directable towards the head of the user (not illustrated), a hand shower head 12 directable towards the hands of the user, a mid-body shower head 13 directable towards the mid-body regions of the user and a lower shower head 14 directable towards the user's feet.

**[0010]** The upper shower head 11 is attached to first conduit means 21, the hand shower head 12 is attached to second conduit means 22, the mid-body shower head 13 is attached to third conduit means 23 and the lower shower head 14 is attached to fourth conduit means 24. Said conduit means 21, 22, 23, 24 are all in communication with the diverter means 15, as illustrated in Fig. 2.

**[0011]** The diverter means are in the form of a ceramic disc diverter valve 15. Said ceramic disc diverter valve comprises a disc carrier 40, a static disc 50, a rotating disc 60, a bush 63, washers 64, a front cover 70, an indenting disc 80, an indenting ball 81 all housed within the diverter body 30. When assembled, as illustrated in Fig. 2, a locking ring 82 secures said disc carrier 40, said static disc 50, said rotating disc 60, said bush 63, said washers 64, said front cover 70 within the diverter body 30. Said indenting disc 80 and said indenting ball 81 are retained by a circlip 84.

**[0012]** The ceramic disc diverter valve 15 is in communication with the mixing means 17 via a fifth conduit means 74 attachable to the front cover 70. Since the mixing means 17 is of the conventional type, and is well known in the art, it shall not be described further herein.

**[0013]** The diverter body 30 comprises apertures 31, 32, 33, 34, all in communication with the conduit means 21, 22, 23, 24, and a central aperture 35 extending therethrough. The disc carrier 40 comprises apertures 41, 42, 43, 44 and a central aperture 45 extending therethrough. The static disc 50 comprises apertures 51, 52, 53, 54 and a central aperture 55 extending therethrough. The rotating disc 60 comprises a central aperture 65 and an aperture 62 extending therethrough. When assembled, a spindle 83 passes through the central apertures 35, 45, 55, 65 and the spindle 83 is secured at one end of the diverter body 30 by a screw 19. When assembled, the apertures 31, 41, 51 and 32, 42, 52 and 33, 43, 53 and 34, 44, 54 are aligned.

**[0014]** With reference to Figs. 3A&B, when the control dial 90 is set to the upper shower head 11 the aperture 62 on the rotating disc 60 is aligned with the apertures 31 located in the diverter body 30, the aperture 41 located in the disc carrier 40 and the aperture 51 located on the static disc 50. Consequently, water originating from the mixing means 17 passes down through the fifth conduit means 74 into the ceramic disc diverter valve 15 through the flow path formed by the aligned apertures 62, 51, 41, 31 up to the upper shower head 11 via conduit means 21 and onto the user.

**[0015]** With reference to Figs. 4A&B, when the control dial 90 is set to the hand shower head 12 the aperture 62 on the rotating disc 60 is aligned with the apertures 32 located in the diverter body 30, the aperture 42 located in the disc carrier 40 and the aperture 52 located on the static disc 50. Consequently, water originating from the mixing means 17 passes down through the fifth conduit means 74 into the ceramic disc diverter valve 15 through the flow path formed by the aligned apertures 62, 52, 42, 32 up to the hand shower head 12 via conduit means 22 and onto the user.

**[0016]** With reference to Figs. 5A&B, when the control dial 90 is set to the mid-body shower head 13 the aperture 62 on the rotating disc 60 is aligned with the apertures 33 located in the diverter body 30, the aperture 43 located in the disc carrier 40 and the aperture 53 located on the static disc 50. Consequently, water originating from the mixing means 17 passes down through the fifth conduit means 74 into the ceramic disc diverter valve 15 through the flow path formed by the aligned apertures 62, 53, 43, 33 up to the mid-body shower head 13 via conduit means 23 and onto the user.

**[0017]** With reference to Figs. 6A&B, when the control dial 90 is set to the lower shower head 14 the aperture 62 on the rotating disc 60 is aligned with the apertures 34 located in the diverter body 30, the aperture 44 located in the disc carrier 40 and the aperture 54 located on the static disc 50. Consequently, water originating from the mixing means 17 passes down through the fifth conduit means 74 into the ceramic disc diverter valve 15 through the flow path formed by the aligned apertures 62, 54, 44, 34 up to the lower shower head 14 via conduit means 24 and onto the user.

**[0018]** So that water originating from the mixing means 17 may be diverted to more than one shower head 11, 12, 13, or 14 at the same time, the apertures 51, 52, 53 and 54 on the static disc 50 may be so arranged so that aperture 62 on the rotating disc 60 can be partially aligned with any two of the apertures 51, 52, 53 or 54 which are adjacent to one another. For example, and with reference to Figs. 7A&B, when the control dial 90 is set to the upper shower head 11 and the mid-body shower head 13 the aperture 62 on the rotating disc 60 is partially aligned with the apertures 31 and 33 located in the diverter body 30, the apertures 41 and 43 located in the disc carrier 40 and the aperture 51 and 53 located on the static disc 50. Consequently, water originating from the mixing means 17 passes down through the fifth conduit means 74 into the ceramic disc diverter valve 15 through the flow path formed by the aligned apertures 62, 51, 53, 41, 43, 31, 33 up to the upper shower head 11 and the mid-body shower head 13 via conduit means 21 and 23 respectively and onto the user.

**[0019]** In order to simply change the direction of the water the user simply rotates the control dial 90 in any direction to the desired position.

**[0020]** Although the present invention has been de-

scribed by way of example to a shower apparatus comprising four shower heads and diverter means which is capable of diverting water to one shower head, or to two shower heads at the same time, by changing the orientation, size, shape or number of both the apertures on the static disc 50 and the rotating disc 60, it is possible to divert water originating from the mixing means 17 up to any selected number of shower heads separately or at the same time.

### Claims

1. A shower apparatus (10) comprising a plurality of shower heads (11;12;13;14) each attached to respective conduit means (21;22;23;24), each of the conduit means (21;22;23;24) also being in communication with a mixing means (17) which is in communication with a hot and cold water supply, in that diverter means (15) being located between the mixing means (17) and each of the conduit means (21; 22;23;24) for diverting water originating from the mixing means (17) either to one shower head (11; 12;13;14) at a time, or alternatively, to more than one shower head (11,13) at the same time **characterised in that** the diverter means (15) comprises a valve means in the form of a ceramic disc diverter valve means (15) comprising a valve housing (30), a first static disc (50) having a plurality of apertures (51-4) provided therein, a second rotating disc (60) having a single aperture (62) therein, the number of apertures (51-4) in the first static disc (50) corresponding to the number of shower heads (11;12;13; 14) utilised, the location of the apertures (51-4;62) in such discs being so arranged and/or the shape of the discs (50;60) being so designed, that, when the rotating disc (60) is rotated it is possible to divert water either to one of the shower heads (11;12;13; 14) at a time, or alternatively, to more than one shower head (11,13) at the same time, and operating means (90) for operating the diverter valve means (15).
2. A shower apparatus (10) as claimed in claim 1, wherein the shower apparatus (10) is in the form of a shower column.
3. A shower apparatus (10) as claimed in claim 1 or 2, wherein the shower apparatus (10) includes 4 shower heads (11;12;13;14).
4. A shower apparatus (10) as claimed in any preceding claim, further comprising drainage means.
5. A shower apparatus (10) as claimed in claim 4, wherein the drainage means is in the form of a linked recess on the surface of the rotating disc (60) which connects the conduits (21;22;23;24) that are

not in use at the same time.

### Patentansprüche

1. Duschvorrichtung (10) mit mehreren Duschköpfen (11; 12; 13; 14), die jeweils an Leitungsmittel (21; 22; 23; 24) angeschlossen sind, wobei jedes der Leitungsmittel (21; 22; 23; 24) auch mit einer Mischeinrichtung (17) in Verbindung steht, die mit einer Kalt- und Heißwasserversorgung in Verbindung steht, wobei eine Ableiteinrichtung (15) zwischen der Mischeinrichtung (17) und jedem der Leitungsmittel (21; 22; 23; 24) angeordnet ist, um Wasser, das von der Mischeinrichtung (17) stammt, entweder auf einmal zu einem Duschkopf (11; 12; 13; 14) oder alternativ gleichzeitig zu mehr als einem Duschkopf (11, 13) abzuleiten, **dadurch gekennzeichnet, daß** die Ableiteinrichtung (15) eine Ventileinrichtung in Form einer Keramikscheibenableitventileinrichtung (15) mit einem Ventilgehäuse (30), einer ersten, festliegenden Scheibe (50) mit mehreren, darin vorgesehenen Öffnungen (51-4) und einer zweiten, rotierenden Scheibe (60) mit einer einzigen Öffnung (62) aufweist, wobei die Anzahl von Öffnungen (51-4) in der ersten, festliegenden Scheibe (50) der Anzahl der verwendeten Duschköpfe (11; 12; 13; 14) entspricht, wobei der Ort der Öffnungen (51-4; 62) in diesen Scheiben derart angeordnet ist und/oder die Form der Scheiben (50; 60) derart ausgelegt ist, daß dann, wenn die rotierende Scheibe (60) gedreht wird, Wasser entweder auf einmal zu einem der Duschköpfe (11; 12; 13; 14) oder alternativ gleichzeitig zu mehr als einem Duschkopf (11, 13) abgeleitet werden kann, sowie Betriebsmittel (90) zum Betrieb der Ableitventileinrichtung (15).
2. Duschvorrichtung (10) nach Anspruch 1, bei welcher die Duschvorrichtung (10) die Form einer Duschsäule hat.
3. Duschvorrichtung (10) nach Anspruch 1 oder 2, bei welcher die Duschvorrichtung (10) vier Duschköpfe (11; 12; 13; 14) umfaßt.
4. Duschvorrichtung (10) nach einem der vorhergehenden Ansprüche, die ferner eine Entwässerungseinrichtung aufweist.
5. Duschvorrichtung (10) nach Anspruch 4, bei welcher die Entwässerungseinrichtung in Form einer angefügten Ausnehmung an der Oberfläche der rotierenden Scheibe (60) vorliegt, die die Leitungen (21; 22; 23; 24) verbindet, die nicht gleichzeitig in Verwendung sind.

## Revendications

1. Un appareil de douche (10) comprenant de multiples têtes de douches (11; 12; 13; 14) étant chacune attachée à leurs moyens de conduite respectifs (21; 22; 23; 24), chacun des moyens de conduite (21; 22; 23; 24) étant en outre en communication avec un moyen de mélange (17), lequel est en communication avec une arrivée d'eau chaude et d'eau froide, des moyens de déviation (15) étant situés entre le moyen de mélange (17) et chacun des moyens de conduite (21 ; 22 ; 23 ; 24) afin de dévier l'eau provenant du moyen de mélange (17) soit vers une tête de douche (11; 12; 13; 14) à la fois, ou alternativement, vers plus d'une tête de douche en même temps, **caractérisé en ce que** le moyen de déviation (15) comprend un moyen de valve dans la forme d'une valve de déviation à disque de céramique (15) comprenant une enceinte de valve (30), un premier disque statique (50) étant pourvu de multiples ouvertures (51-4), un second disque rotatif (60) étant pourvu d'une seule ouverture (62), le nombre d'ouvertures (51-4) dans le premier disque statique (50) correspondant au nombre de têtes de douche (11; 12 ; 13 ; 14) utilisé, l'emplacement des ouvertures (51-4 ; 62) dans de tels disques étant arrangé et/ou la forme des disques (50 ; 60) étant conçue de telle sorte que, quand le disque rotatif (60) est mis en rotation il est possible de dévier l'eau soit vers l'une des têtes de douches (11 ; 12 ; 13 ; 14) à la fois, ou alternativement, vers plus d'une tête de douche (11, 13) en même temps, et des moyens d'actionnement (90) pour actionner des moyens de valve de déviation (15).
 

5  
10  
15  
20  
25  
30
2. Un appareil de douche (10) selon la revendication 1, dans laquelle l'appareil de douche (10) a la forme d'une colonne de douche.
 

35
3. Un appareil de douche (10) selon la revendication 1 ou 2, dans laquelle l'appareil de douche (10) comprend 4 têtes de douches (11 ; 12 ; 13 ; 14).
 

40
4. Un appareil de douche (10) selon une quelconque des revendications précédentes, comprenant en outre des moyens d'écoulement.
 

45
5. Un appareil de douche (10) selon la revendication 4, dans laquelle le moyen d'écoulement a la forme d'une niche correspondante sur la surface du disque rotatif (60) qui relie les conduits (21 ; 22 ; 23 ; 24) qui ne sont pas utilisés en même temps.
 

50

55

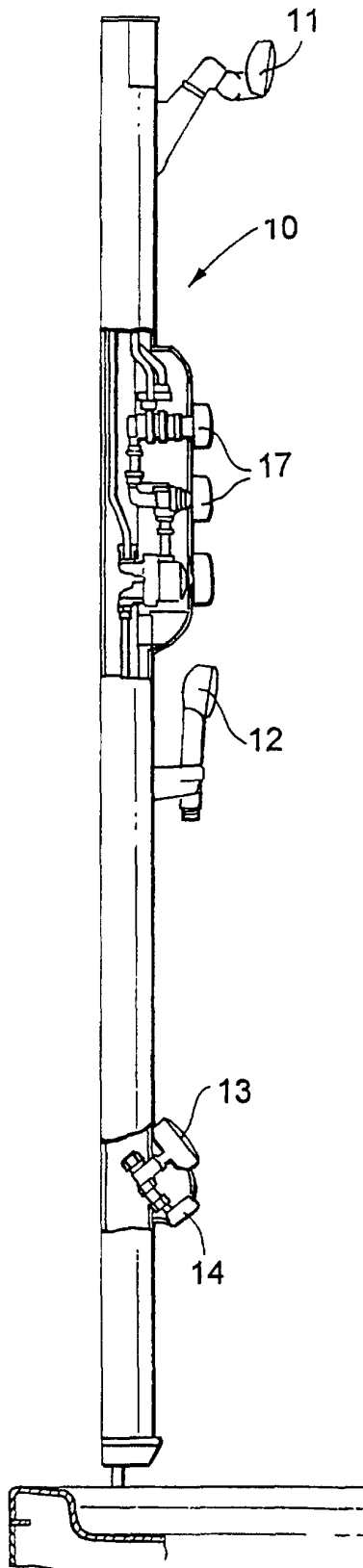

FIG. 1A

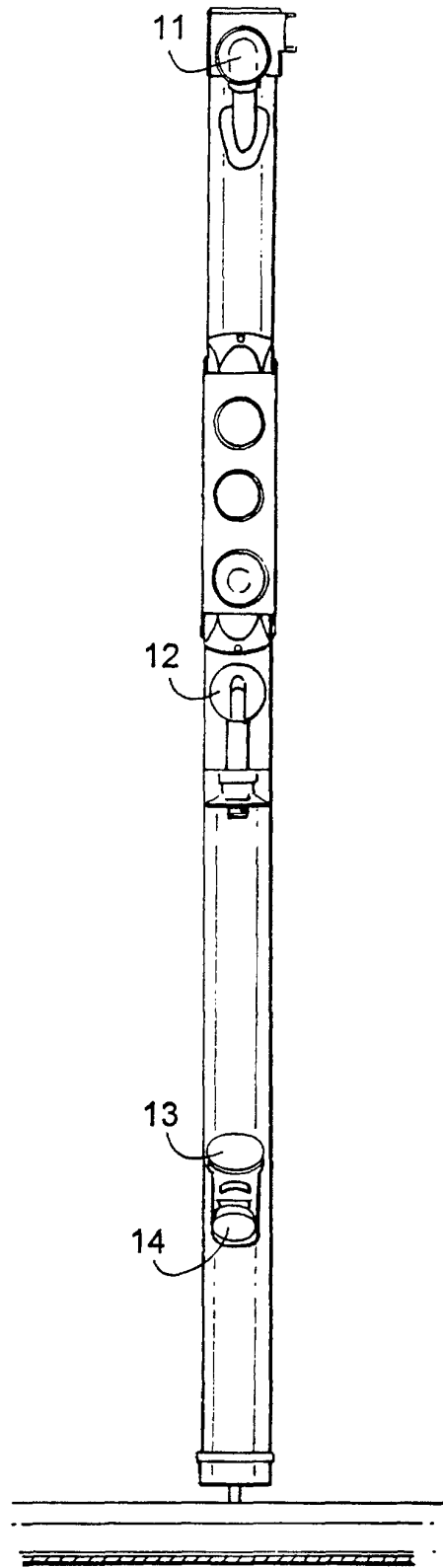

FIG. 1B

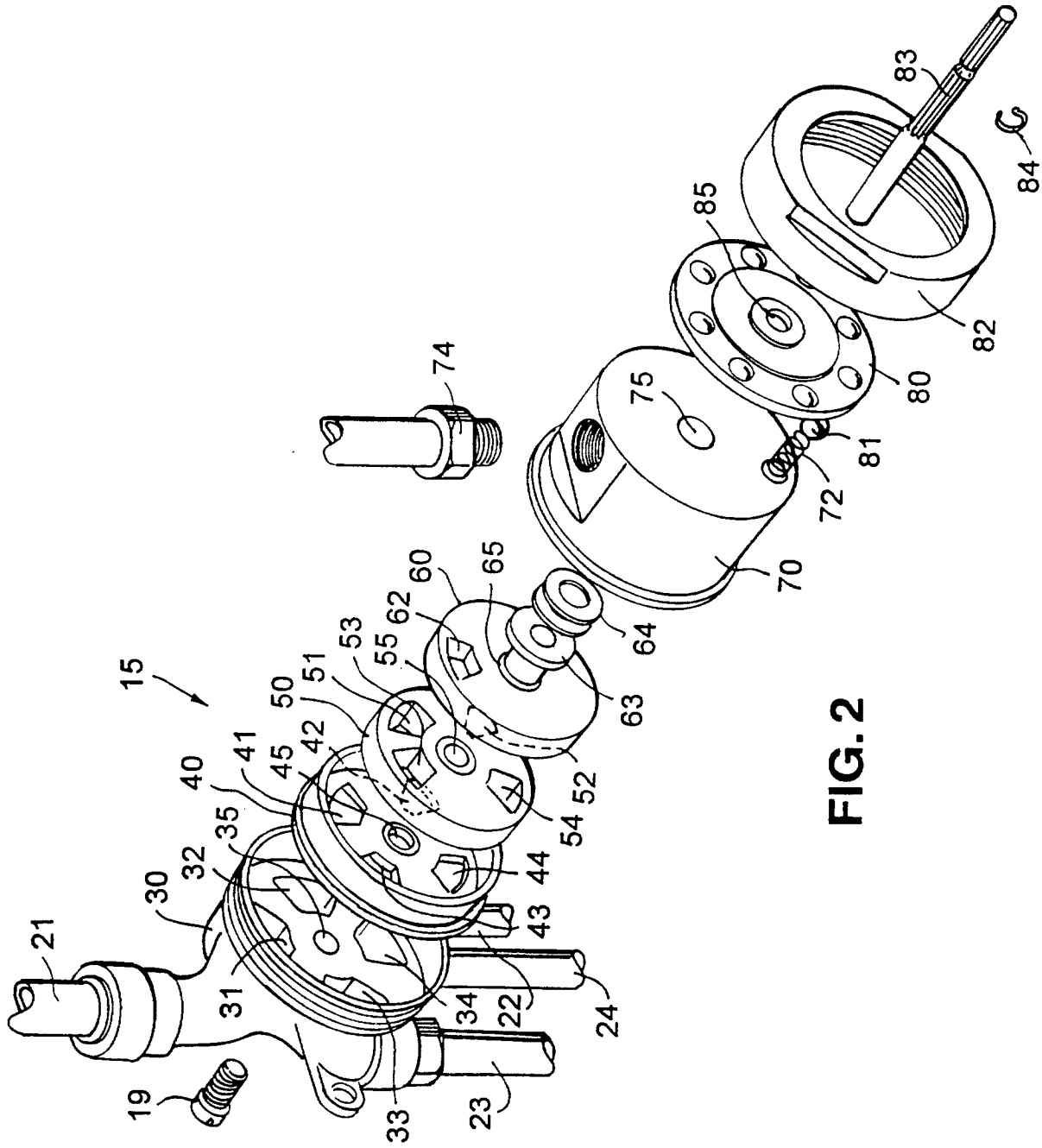

FIG. 2

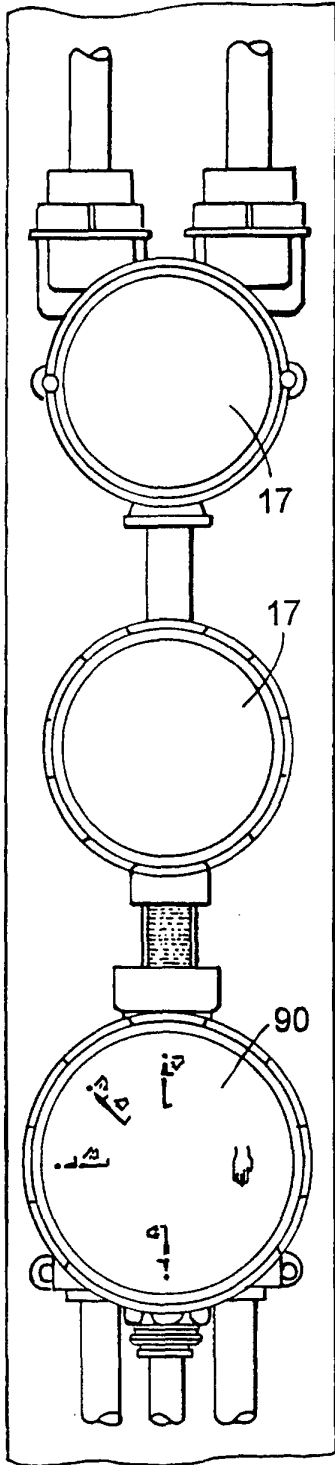

FIG. 3A

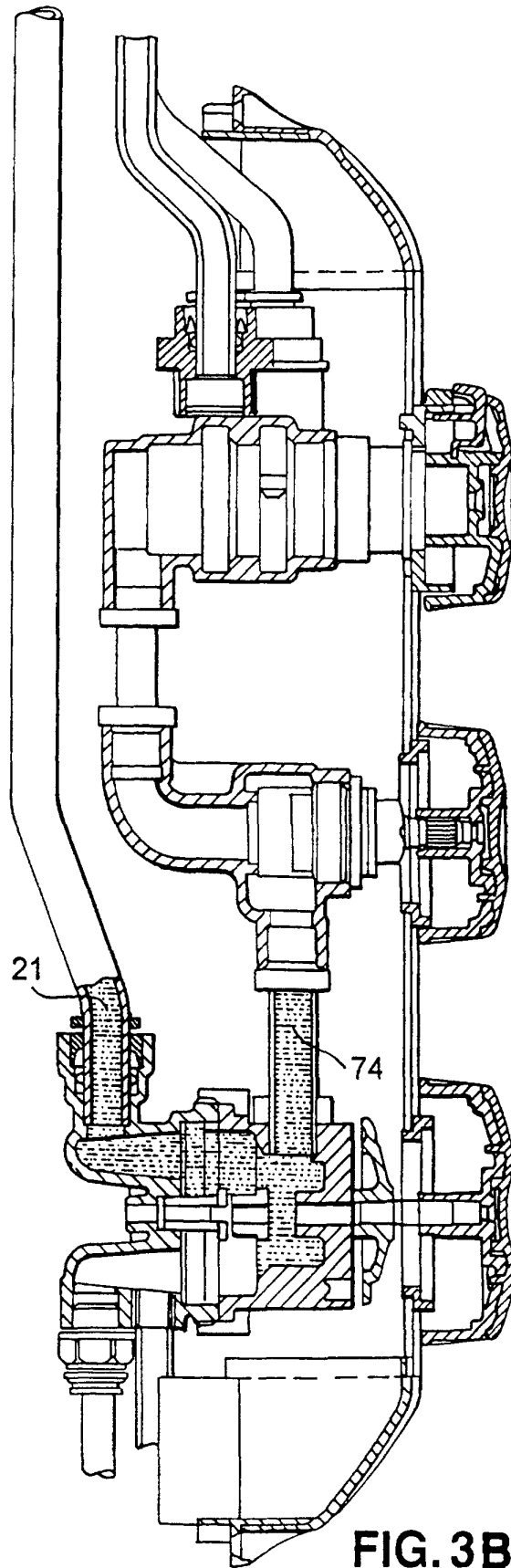

FIG. 3B

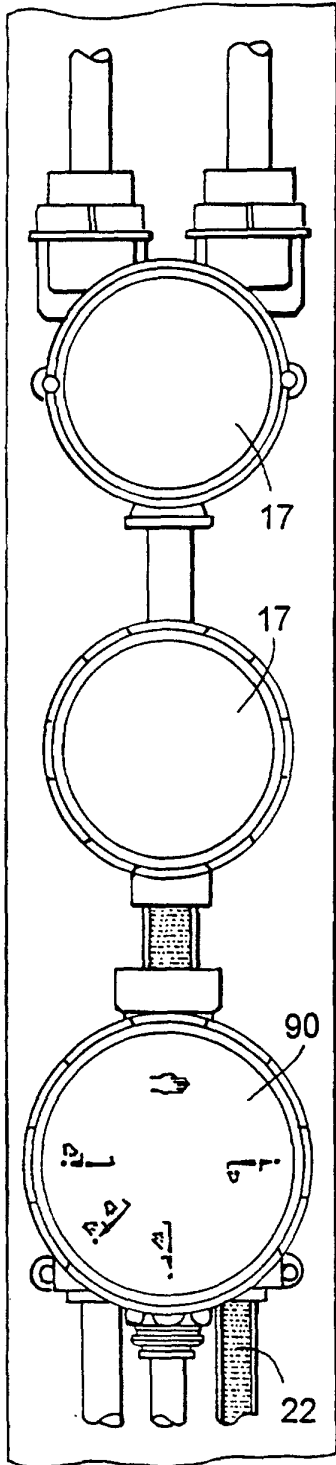

FIG. 4A

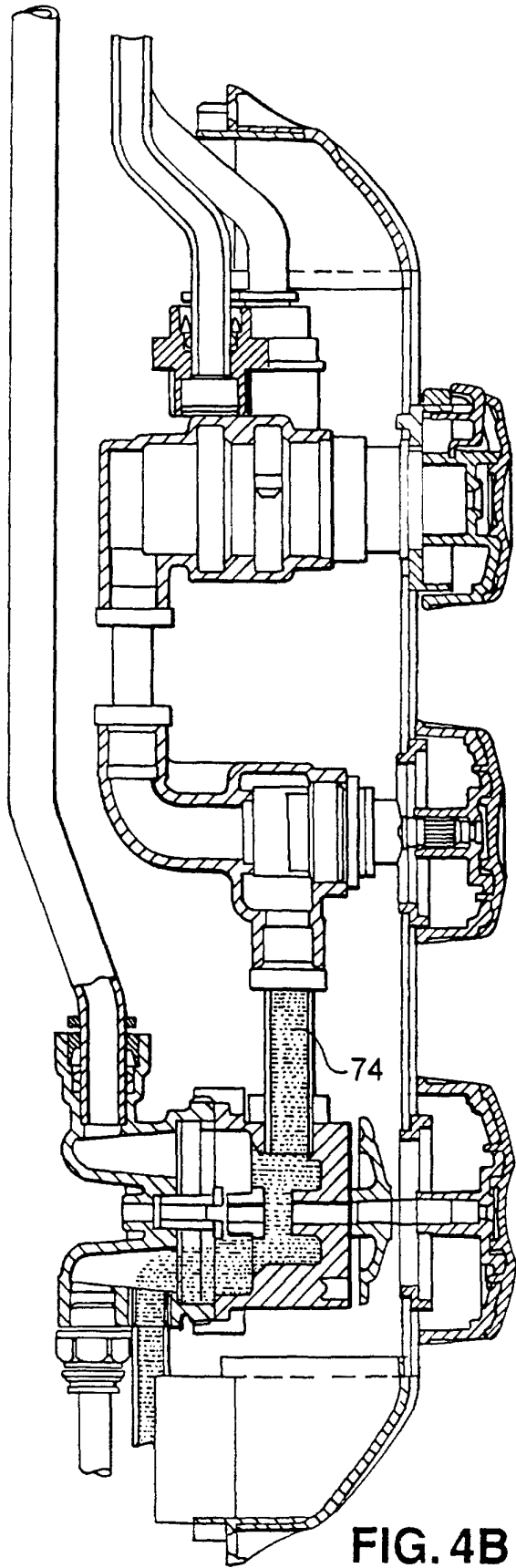

FIG. 4B

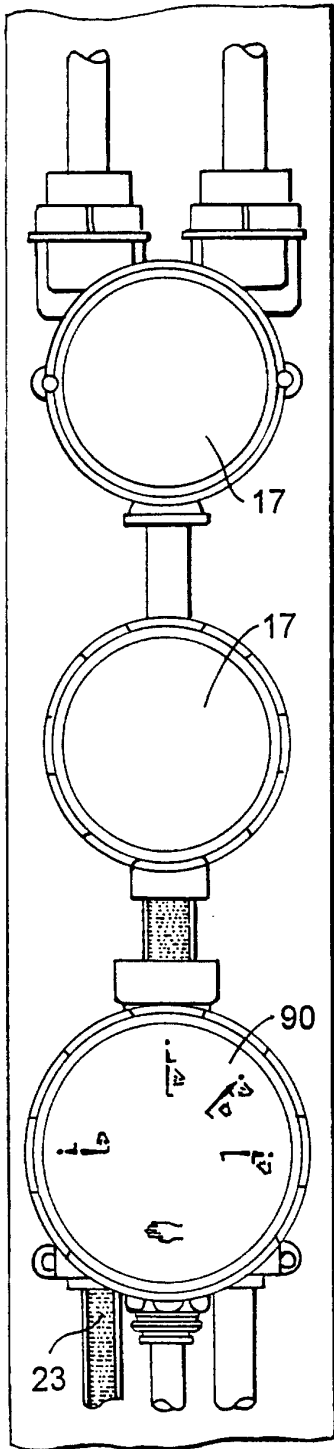

FIG. 5A

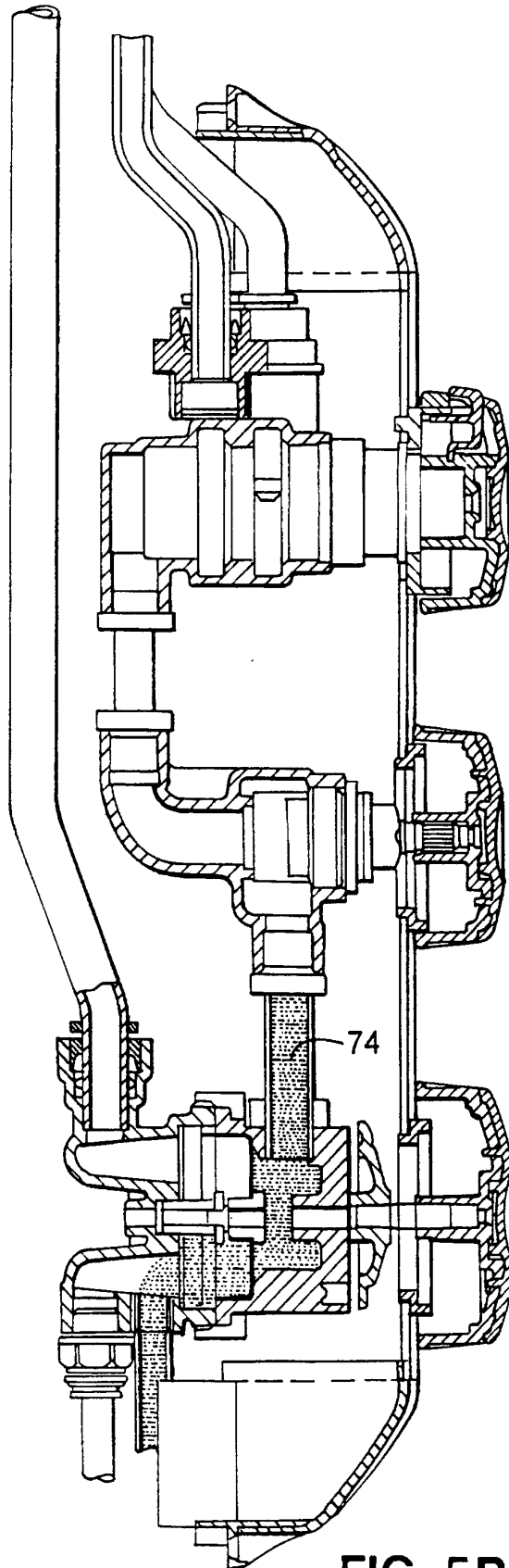

FIG. 5B

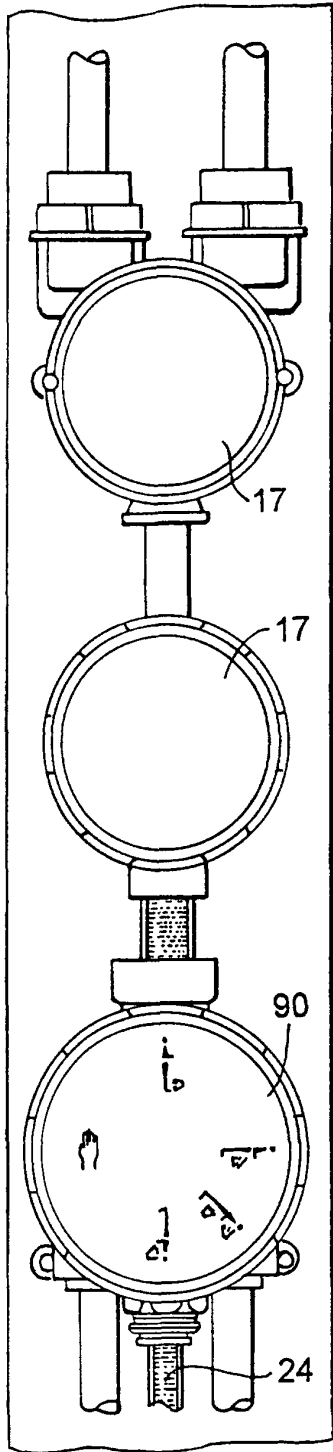

FIG. 6A

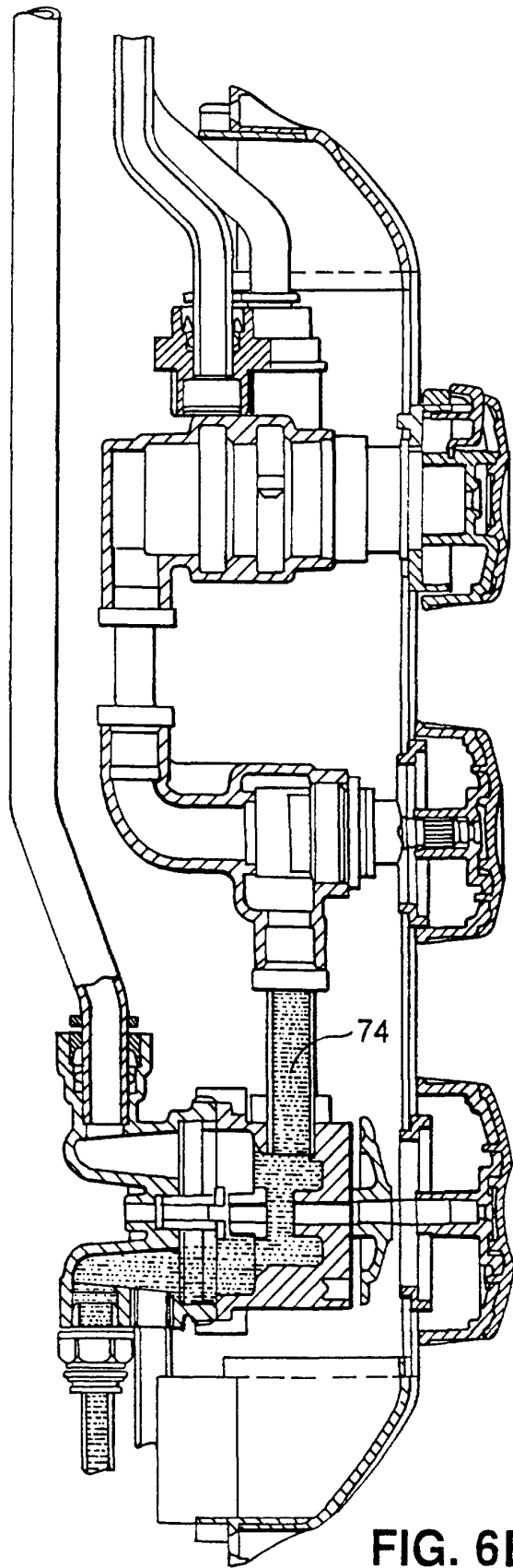

FIG. 6B

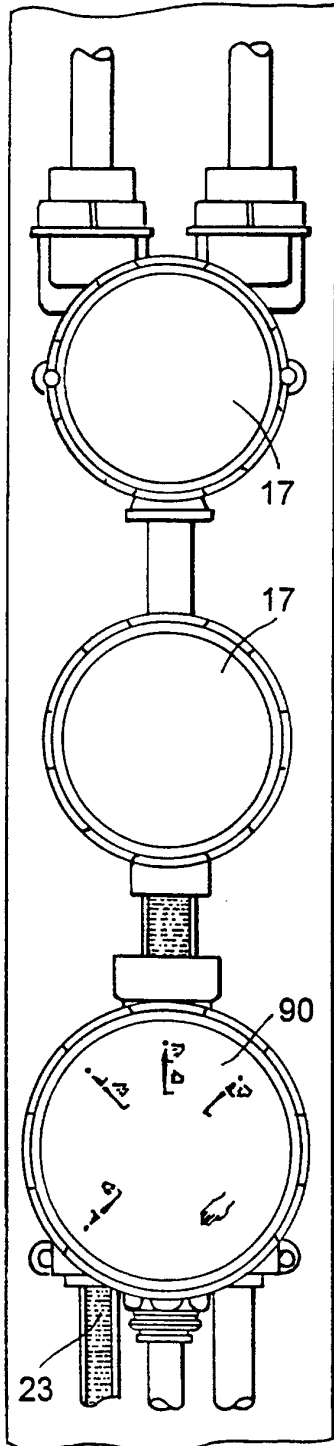

FIG. 7A

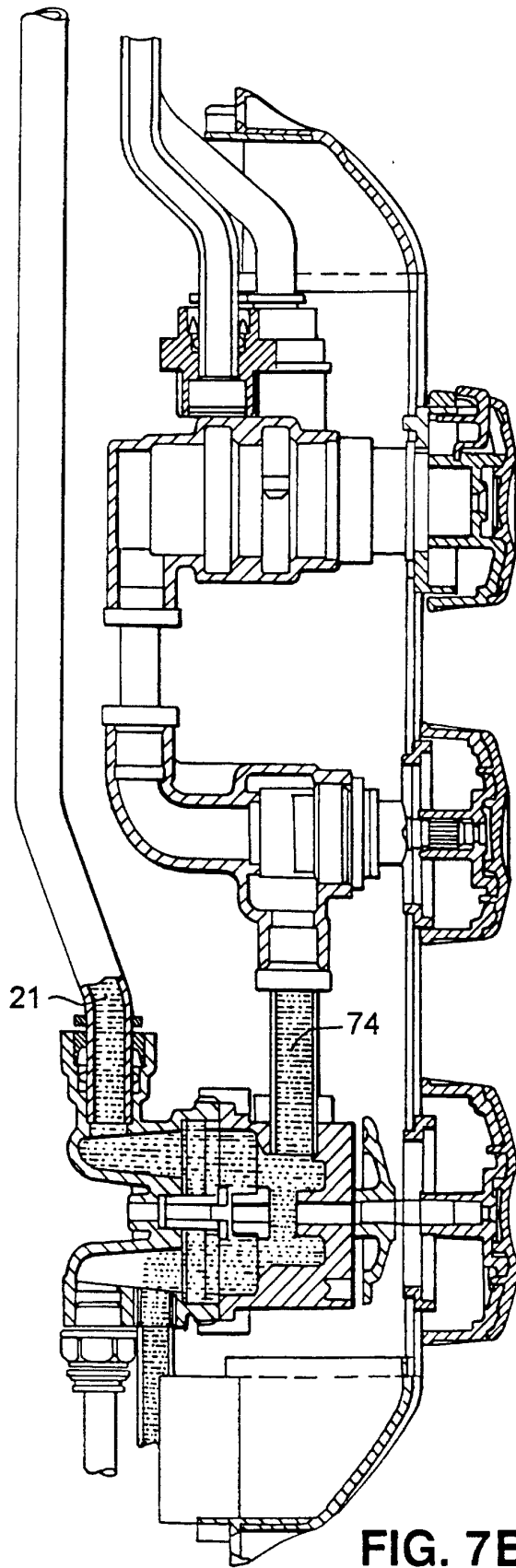

FIG. 7B