

(19) World Intellectual Property  
Organization  
International Bureau



(43) International Publication Date  
17 March 2005 (17.03.2005)

PCT

(10) International Publication Number  
WO 2005/023340 A1

- (51) International Patent Classification<sup>7</sup>: A61M 5/158
- (21) International Application Number:  
PCT/US2004/022579
- (22) International Filing Date: 13 July 2004 (13.07.2004)
- (25) Filing Language: English
- (26) Publication Language: English
- (30) Priority Data:  
10/648,969 27 August 2003 (27.08.2003) US
- (71) Applicant (for all designated States except US): C.R. BARD, INC. [US/US]; 730 Central Avenue, Murray Hill, NJ 07974 (US).
- (72) Inventors; and
- (75) Inventors/Applicants (for US only): TRIPLETT, Daniel, J. [US/US]; 583 South 225 East, Providence, UT 84332 (US). SHEETZ, Kevin, W. [US/US]; 10109 Bannor Hill Road, Sandy, UT 84092 (US). BURNSIDE, Eddie, K. [US/US]; 3842 N. 4000 W., Morgan, UT 84050 (US).
- (74) Agents: WIGHT, Todd, W. et al.; Morrison & Foerster LLP, 555 W. Fifth Street, Suite 3500, Los Angeles, CA 90013 (US).
- (81) Designated States (unless otherwise indicated, for every kind of national protection available): AE, AG, AL, AM, AT, AU, AZ, BA, BB, BG, BR, BW, BY, BZ, CA, CH, CN, CO, CR, CU, CZ, DE, DK, DM, DZ, EC, EE, EG, ES, FI, GB, GD, GE, GH, GM, HR, HU, ID, IL, IN, IS, JP, KE, KG, KP, KR, KZ, LC, LK, LR, LS, LT, LU, LV, MA, MD, MG, MK, MN, MW, MX, MZ, NA, NI, NO, NZ, OM, PG, PH, PL, PT, RO, RU, SC, SD, SE, SG, SK, SL, SY, TJ, TM, TN, TR, TT, TZ, UA, UG, US, UZ, VC, VN, YU, ZA, ZM, ZW.
- (84) Designated States (unless otherwise indicated, for every kind of regional protection available): ARIPO (BW, GH, GM, KE, LS, MW, MZ, NA, SD, SL, SZ, TZ, UG, ZM, ZW), Eurasian (AM, AZ, BY, KG, KZ, MD, RU, TJ, TM), European (AT, BE, BG, CH, CY, CZ, DE, DK, EE, ES, FI, FR, GB, GR, HU, IE, IT, LU, MC, NL, PL, PT, RO, SE, SI, SK, TR), OAPI (BF, BJ, CF, CG, CI, CM, GA, GN, GQ, GW, ML, MR, NE, SN, TD, TG).

[Continued on next page]

(54) Title: SAFETY NEEDLE WITH POSITIVE FLUSH

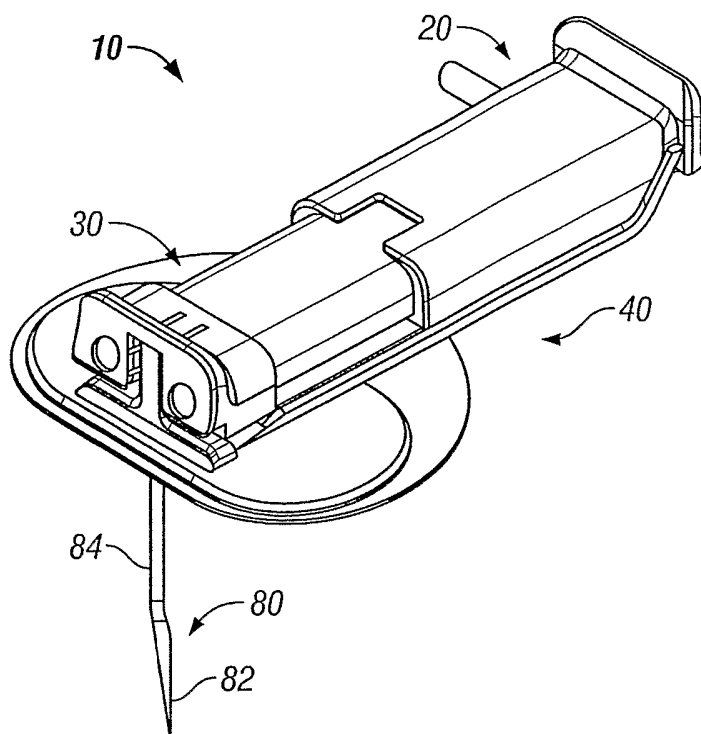

(57) Abstract: A safety needle device and positive flush mechanism for use with a vascular access port. In one embodiment, the combination needle assembly includes a needle, a body and a base, the body being collapsible to expunge fluid therefrom as the needle is withdrawn from a vascular access port. In another embodiment, the combination needle assembly includes a needle, a housing and a reservoir, the housing squeezing the reservoir to expunge fluid therefrom as the needle is withdrawn from the port. In another embodiment, the needle assembly includes a compression plate and balloon extension, the compression plate forcing fluid out of the balloon extension as the needle is withdrawn from the port. In all embodiments, the needle assembly is configured to provide a positive flush to overcome negative pressures in the vascular access port, while also providing a locking mechanism to prevent accidental needle sticks.

WO 2005/023340 A1



**Published:**

— *with international search report*

*For two-letter codes and other abbreviations, refer to the "Guidance Notes on Codes and Abbreviations" appearing at the beginning of each regular issue of the PCT Gazette.*

**SAFETY NEEDLE WITH POSITIVE FLUSH**

## CROSS-REFERENCE TO RELATED APPLICATIONS

[0001] Not applicable.

STATEMENT REGARDING FEDERALLY SPONSORED  
RESEARCH OR DEVELOPMENT

[0002] Not applicable.

## REFERENCE TO A COMPACT DISK APPENDIX

[0003] Not applicable.

## BACKGROUND OF THE INVENTION

[0004] The present invention relates generally to medical devices and more particularly to needle safety devices and positive flushing mechanisms.

[0005] Implantable vascular access systems are used extensively in the medical field to facilitate the performance of recurrent therapeutic tasks inside the body of a patient. Such vascular access systems generally include an implantable vascular access port attached to a vascular catheter. A typical vascular access port has a needle-impenetrable housing that encloses a fluid reservoir that is accessible from the exterior of the access port through a needle-penetrable elastomeric septum.

[0006] The entirety of the system, both the vascular access port and the catheter attached thereto, is implanted in the body of a patient. The distal tip of the catheter is disposed at a predetermined location where therapeutic activity is to be effected. Once the vascular access system is implanted, the tip of a hypodermic needle can then be employed selectively and repeatedly to access the fluid reservoir of the access port by penetrating the skin at the implantation site for the access port and then by being advanced through the septum of the access port itself.

[0007] While often times syringe-type devices are utilized for vascular access ports in acute or short-term situations, a special type of device is utilized for longer term infusion therapy. Such an infusion assembly device generally consists of a needle and wing assembly that lies flat against the skin in an insertion position, the

needle having a proximal end attached to a wing assembly that is in angular relation to the needle shank, the angle being approximately 90°. As mentioned, when this longer term needle device is inserted into the vascular access port, it lies flat against the patient's skin and is adhered thereto as described, for example, in U.S. Patent No. 4,710,176 to Quick.

**[0008]** With respect to the needle tip of the needle used in infusion assemblies for vascular access ports, a non-coring configuration is generally utilized due to repeated entry of the needle into the septum of the vascular access port. When the tip of a hypodermic or other traditional needle advances through the septum, coring occurs if any portion of the septum material is forced inside the shaft of the needle through the opening in the tip thereof. That portion of the septum material forced inside a needle in this process is in effect severed from the rest of the body of the septum material. Such septum coring produces small, detached particles of the septum that are likely to enter the fluid that is infused by the implanted vascular access system into the vascular system of the patient. These particles can obstruct fluid flow through the outlet stem of the vascular access port, or if escaping through the outlet stem of the vascular access port, can become trapped in the cardiovascular system of the patient.

**[0009]** In addition, septum coring produces small passageways through the body of a septum. On occasion these passageways extend entirely through the septum, from the exterior thereof to the fluid reservoir inside the vascular access port. The inwardly directed forces imposed on the installed septum by the housing of a vascular access port should initially urge the material of the body of the septum inwardly upon itself to close such passageways after the shaft of the needle is withdrawn therefrom. Nonetheless, continued coring eventually leads to various forms of septum failure that cannot be overcome by such inwardly directed forces. The material continuity of the septum is increasingly compromised, resulting in crumbled areas of the septum matrix. Eventually, leakage of fluid can be expected through the septum from the fluid reservoir in the vascular access port. Once such fluid escapes to the exterior of the vascular access port, necrosis will occur of the tissue surrounding the subcutaneous pocket in which the vascular access port is implanted, causing many undesirable consequences. Therefore, non-coring or Huber needles are preferably

used in conjunction with infusion assemblies for vascular access ports. These needles, in contradistinction to the standard or traditional hypodermic needles pierce the septum like a knife, facilitating the resealing thereof so that the aforementioned problems are largely averted.

**[0010]** As with any needle-type device, there exists the problem of inadvertent needle sticks, which generally occurs when the needle-type device is withdrawn from the patient prior to appropriate disposal thereof. Of course, inadvertent needle sticks introduce a variety of concerns due to unwanted transmission of blood from the patient to the medical practitioner. Inadvertent needle sticks can occur because of carelessness on the part of the medical practitioner or due to accidents in the handling of devices with exposed needle tips. With respect to Huber needles specifically, needle stick accidents can occur due to difficulty in removal as well. This difficulty results from the configuration of the Huber needle, which gets hooked into the port making it difficult to remove. Increased pulling force on behalf of the medical practitioner to dislodge the needle from the port results in less control over the tip of the needle when freed from the port, causing the inadvertent needle stick.

**[0011]** To address the inadvertent needle stick problem in winged infusion assemblies, such as those described herein, various safety devices have been designed to encase the needle after it is withdrawn from the port. One such safety device is described in U.S. Patent No. 5,755,694 to Camus. Camus discloses a needle base disposed over a segment of the needle at its proximal end, comprising two generally flat wings made of flexible material with one hinge connecting each of the wings to the needle base. Upon removal of the needle from the patient the wings flex against a moveable member that keeps them adjacent the needle until the needle is completely removed from the skin of a patient after which the wings surround the needle to prevent the tip from making contact outside of the needle base.

**[0012]** Another type of safety device is described in U.S. Patent No. 5,951,522 to Rosato et al., in which the particular configuration of the Huber needle is also taken into account. Rosato et al. discloses a safety enclosure comprising a wing assembly mounted to the aft end of a angled Huber needle, the wing assembly having a configuration consisting of either a single integral member having a plurality of

spaced apart fold lines which divide the member into a plurality of interconnected panels, or a pair of wing members mounted in a scissors-type arrangement. In each embodiment, when the medical practitioner removes the needle from the patient, the wing assembly closes around the needle and locks together, encasing it therein.

**[0013]** While many advancements have been made in the area of needle devices for use with vascular access ports, such as those described herein, there remains a heretofore unsolved problem related to removal of the needle device from the vascular access port. When the needle is inserted through the septum, it occupies a volume equal to the external dimensions thereof present in the fluid reservoir positioned underneath the septum. When the needle is removed from the vascular access port, the needle volume is evacuated without replacement, causing an equivalent volume of venous fluid to be drawn into the catheter tip at the distal end thereof. This infiltration of venous fluid is suspected to cause or contribute to thrombus formation at the catheter tip, which blocks the flow of fluid therethrough and results in early removal of the port and catheter from the patient. Early removal is costly, invasive and time-consuming and otherwise extremely undesirable.

**[0014]** One solution to this problem of unwanted venous fluid being drawn into the catheter tip has been to implement a positive flushing technique as the needle is withdrawn. This technique generally consists of the medical practitioner inserting a syringe into the port and injecting a solution such as heparin while simultaneously withdrawing the needle. This technique, however, can be quite cumbersome and complicated and in fact may require more than one operator, as many of the infusion sets for use with vascular access ports require two hands to withdraw. For these reasons and others, it is known that a significant population of medical practitioners forego the practice of the described technique despite the adverse consequences that could result, as outlined herein. Therefore, it would be desirable to incorporate a flushing mechanism into a needle infusion set for use with a vascular access port so that flushing upon removal of the needle from the septum is assured.

**[0015]** In particular, it would be desirable to incorporate a positive flushing mechanism into various needle assemblies, one of which being an improved infusion

needle assembly for use with a vascular access port that also provides a safety feature to prevent needle sticks.

#### BRIEF SUMMARY OF THE INVENTION

**[0016]** Accordingly, a primary object of the present invention is to provide a needle assembly that incorporates a positive flushing mechanism. It is another object of the present invention to provide an improved needle assembly that will prevent accidental needle sticks upon the removal of the needle from the patient. It is yet another object of the present invention to provide an improved needle assembly that is configured to account for the geometry of a Huber needle. It is still another object of the present invention to provide a method of withdrawing a safety infusion set from a patient. It is a further object of the present invention to provide a method of positively flushing a vascular access port during withdrawal of the safety infusion set from a patient. Various other objectives and advantages of the present invention will become apparent to those skilled in the art as more detailed description is set forth below.

**[0017]** In accordance with the present invention, several embodiments are described, which may be improvements to prior art needle assemblies or may be novel infusion needle set embodiments heretofore undisclosed. As used herein, the following terms have the following meanings:

**[0018]** "Vascular access port" refers to a port having a needle-impenetrable housing enclosing a fluid reservoir that is accessible from the exterior of the port through a needle-penetrable elastomeric septum.

**[0019]** "Positive flush" refers to the action of a fluid being sent through a needle as the needle is being removed from a reservoir of a vascular access port or similar device so that the fluid replaces the volume that the needle occupies within the reservoir. It should be noted that the actual amount of fluid being sent through the needle will be greater than the volume of the needle in most cases.

**[0020]** In one embodiment of the present invention, a needle assembly is provided, including a needle, a body and a base. The body is in the form of a collapsible male and female portion, where the collapsing action produces the positive flush following delivery of a drug or medicine to an implanted vascular

access port. The base includes a contact patch that lies flat against the patient's skin for delivery of the drug or medicine and, which facilitates removal of the needle from the vascular access port. An arm and a hinge are attached to the contact patch, being respectively connected to the male and female portions of the body. When the needle assembly is moved from an insertion position to a protection position, the collapsing action of the body flushes fluid therefrom simultaneous to the needle exiting the vascular access port, creating a positive flush and preventing any negative pressures therein. The needle assembly contains a primary and secondary locking mechanism to ensure that accidental needle sticks are avoided.

**[0021]** In an alternate embodiment of the present invention, a winged assembly is provided, including a needle, a needle housing and a collapsible reservoir. The needle housing has an upper and lower portion that are connected to one another. The upper portion houses the collapsible reservoir, which is adhered thereto in a way that allows complete and uniform collapse. The proximal end of the needle is attached to the front end of the upper portion and is fluidly connected to the collapsible reservoir. A connector is attached to the rear end of the upper portion, also in fluid communication with the reservoir, the connector being configured for attachment to an extension tubing set. The lower portion contains four connected panels, having locking mechanisms associated therewith to releasably lock the winged assembly in the insertion position and to permanently lock the winged assembly in the protection position. When the winged assembly is moved from an insertion position to a protection position, extensions on the lower portion of the needle housing press against the collapsible reservoir simultaneous to the needle exiting the vascular access port, expunging fluid therein through the needle to create a positive flush.

**[0022]** In another embodiment of the present invention, a needle assembly is provided, including a needle, a handle, a wing base and a support structure. The handle has a left and right half which are connected together around a balloon extension that is connected to the proximal end of the needle and is in fluid communication therewith, and a compression plate that is connected to legs of the support structure. The support structure is bonded to the bottom of the wing base, the legs thereof fitting through holes in the wing base. The handle is movable with respect to the wing base and support structure for movement from an insertion position to a



protection position. The balloon extension is trapped between the compression plate and handle so that movement of the handle upward results in compression of the balloon extension. As the balloon extension is compressed, the fluid contained therein is flushed through the needle as the needle exits a vascular access port to create a positive flush.

**[0023]** These and other embodiments, features and advantages of the present invention will become more apparent to those skilled in the art when taken with reference to the following more detailed description of the invention in conjunction with the accompanying drawings that are first briefly described.

#### BRIEF DESCRIPTION OF THE DRAWINGS

**[0024]** Fig. 1 is a perspective view of a needle assembly according to the present invention in the insertion position.

**[0025]** Fig. 2 is a perspective view of the needle assembly of Fig. 1 in the protection position.

**[0026]** Fig. 3 is a perspective view of the base portion of the needle assembly of Fig. 1 in the insertion position of Fig. 1.

**[0027]** Fig. 4 is a perspective view of the base portion of the needle assembly of Fig. 1 in the protection position of Fig. 2.

**[0028]** Fig. 5A is a close-up cross-sectional view of the needle housing of the needle assembly of Fig. 1 in the insertion position.

**[0029]** Fig. 5B is a close-up cross-sectional view of the needle housing of the needle assembly of Fig. 1 in the protection position.

**[0030]** Fig. 6 is a bottom perspective view of the male portion of the body of the needle assembly of Fig. 1.

**[0031]** Fig. 7 is a top perspective view of the male portion of the body of the needle assembly of Fig. 1.

[0032] Fig. 8 is a perspective view of the proximal end of the female portion of the body of the needle assembly of Fig. 1.

[0033] Fig. 9 is a perspective view of the distal end of the female portion of the body of the needle assembly of Fig. 1.

[0034] Fig. 10 is a top cross-sectional view of the needle assembly of Fig. 1 in the insertion position of Fig. 1.

[0035] Fig. 11 is a top cross-sectional view of the needle assembly of Fig. 1 in the protection position of Fig. 2.

[0036] Fig. 12 is a side cross-sectional view of the needle assembly of Fig. 1 in the insertion position of Fig. 1.

[0037] Fig. 13 is a side cross-sectional view of the needle assembly of Fig. 1 in the protection position of Fig. 2.

[0038] Fig. 14 is a perspective view of an alternate embodiment of the needle assembly of the present invention in the insertion position.

[0039] Fig. 15 is a perspective view of the needle assembly of Fig. 14 in the protection position.

[0040] Fig. 16 is a perspective view of the upper portion of the needle assembly of Fig. 14 with an attached collapsible reservoir.

[0041] Fig. 17 is a view of the lower portion of the needle assembly of Fig. 14.

[0042] Fig. 18 is a perspective view of an alternate embodiment of the needle assembly of the present invention.

[0043] Fig. 19 is a bottom view of the needle assembly of Fig. 18.

[0044] Fig. 20 is a front view of the needle assembly of Fig. 18.

[0045] Fig. 21 is a side view of the needle assembly of Fig. 18.

[0046] Fig. 22 is an exploded view of the needle assembly of Fig. 18.

[0047] Fig. 23 is side cross-sectional view of the needle assembly of Fig. 18 in the insertion position.

[0048] Fig. 24 is a side cross-sectional view of the needle assembly of Fig. 18 in the protection position.

#### DETAILED DESCRIPTION OF THE INVENTION

[0049] The following detailed description should be read with reference to the drawings, in which like elements in different drawings are identically numbered. The drawings, which are not necessarily to scale, depict selected preferred embodiments and are not intended to limit the scope of the invention. In particular, although the examples provided herein are related to use of the described embodiments with an implanted vascular access port, it is contemplated that the positive flushing feature could be used with other medical devices to avert negative pressures upon the removal of needles or other medical equipment from a sealed system.

[0050] The detailed description illustrates by way of example, not by way of limitation, the principles of the invention. This description will clearly enable one skilled in the art to make and use the invention, and describes several embodiments, adaptations, variations, alternatives and uses of the invention, including what is presently believed to be the best mode of carrying out the invention.

[0051] In a first embodiment of the present invention, a safety needle assembly with positive flushing mechanism 10 is shown in Fig. 1. The assembly 10 is shown in the insertion or use position, ready for insertion into the septum of an implanted vascular access port within a patient (not shown). The assembly 10 has three main components: a body, having a male portion 20 and a female portion 30, a base 40 and a needle 80. The male portion 20 is attachable to an extension tubing set for delivery of a fluid through the body to the needle 80, where it is dispensed into the vascular access port. The male portion 20 and female portion 30 are collapsible so that following delivery of the fluid to the vascular access port, the fluid within the body can be expunged as the needle is withdrawn from the vascular access port, creating a positive flush. The collapsible action of the body during withdrawal of the

needle 80 occurs simultaneously with mechanical precision as will be explained in detail below. The body and base 40 in this embodiment are constructed of plastic, although certainly a number of different materials are possible, as one of skill in the art would appreciate. The needle 80 has a non-coring configuration, meaning that the tip 82 of the needle is angularly bent with respect to the longitudinal axis of the needle shank 84.

**[0052]** Fig. 2 illustrates the assembly 10 in the protection or safe position, following withdrawal of the needle 80 from the vascular access port. From this view, the various elements of the base 40 can be seen. Base 40 includes a contact patch 42, which is a flat portion that rests against the skin of a patient and can be held thereto by a clinician as he begins withdrawal of the needle 80 from the vascular access port to maintain the position of the assembly 10 and allow for smooth mechanical interaction of the various components in providing the inventive positive flush. While the contact patch 42 is shown in a flat, rounded configuration, there are various other configurations that would equally be within the scope of the present invention, including configurations that take into account the particular area and contour of the body on which the assembly 10 is to be mounted so that the assembly 10 lies flush against the patient. In such an embodiment, the contact patch 42 would not have to be flat and instead could assume a variety of shapes as one of skill in the art should appreciate. It is noted that the use of a contact patch is advantageous in stabilizing the needle assembly 10 and facilitating smooth withdrawal of the needle, particularly in the event that the needle is stuck in the vascular access port or is otherwise difficult to remove.

**[0053]** Attached to the contact patch 42 is an arm 44. The arm 44 is either permanently connected to the contact patch 42 (through gluing, welding, etc.) at a first end 48 or is constructed as a single piece "living hinge" design. Opposite first end 48, the arm has a snap-fit interface 46 for unidirectional connection to the male portion 20 of the body. The unidirectional connection permits division between components (*i.e.*, manufacturability) while ensuring that the safety feature of the design is not defeated. Integrally connected to the arm 44 and adjacent the first end 48 thereof is a hinge 50 for connection to the female portion 20 of the body to serve as a range of motion limit, which prevents over extension of the safety feature. The hinge 50 can be seen in

more detail in Figs. 3 and 4, showing the base 40 in the insertion position and protection position without the body for a clear view of the elements of the base 40 and their relative positions and movement in the two indicated positions of the assembly 10. Referring first to Fig. 3, the base 40 is shown in the insertion position, with arm 44 substantially flat against the contact patch 42 and hinge 50 folded within aperture 45 of arm 44. Pin interface 58 of the hinge 50 for connection to the female portion 20 is shown in its attached position.

[0054] Fig. 4 illustrates the base 40 in the protection position as both the arm 44 and the hinge 50 are moved in an upward direction with respect to the contact patch, which remains stationary against the skin of the patient. In this position, the full length of the hinge 50 can be seen, including an upper and lower portion connected by a hinge point 56. Also seen is a needle housing 60, positioned on the contact patch 48 abutting the first end 48 of the arm 44. The needle housing 60 has an open shaft 66 therethrough to permit passage of the needle 80. The needle housing 60 traps the needle therein when the assembly 10 is in the protection position, thereby providing a secondary locking mechanism to complement the primary locking mechanism provided by the body.

[0055] Referring to Figs. 5A and 5B, one embodiment of needle housing 60 is provided. In this embodiment, the needle 80 passes through the needle housing shaft 66 and the distal opening 62 of the needle housing 60 as shown in Fig. 5A in the insertion position. The distal opening 62 of the needle housing 60 is smaller in diameter than the needle housing shaft 66, creating a ledge 64. Due to the non-coring configuration of needle 80 (where needle tip 82 is offset from needle shank 84) and the fact that the distal opening 62 is closely sized to the diameter of the needle shank 84, when the needle tip 82 passes through the distal opening 62 in a proximal direction, the tip 82 is deflected so that it may pass through the distal opening 62. As the needle 80 is drawn further in a proximal direction, the needle tip 82 enters the larger diameter needle shaft 66 where it returns to its initial axial position with respect to the distal opening 62 as shown in Fig. 5B in the protection position. This action results in the needle tip 82 being biased within the needle shaft 66, as movement in the distal direction is prevented by ledge 64. Variations to this embodiment include wedge or cone shaped features on the ledge 64 to further assist in preventing distal

movement of the needle tip 82 through the distal opening 62. Other embodiments which would be apparent to one of skill in the art are also possible, depending on the shape and size of the needle.

**[0056]** Referring now to Figs. 6-9, the male portion 20 and the female portion 30 of the body are shown separately. In Figs. 6 and 7, the male portion 20 is shown from a bottom (Fig. 6) and a top (Fig. 7) viewpoint. The male portion 20 has an extension leg tubing connector 26, a plunger 22 and two guide pins 23. The guide pins 23 are positioned on each side of the plunger 22 and contain at their distal end knobs 24 that act as a closure locking mechanism when received in recesses within the female portion 30. The knobs 24 have an expanded and a contracted diameter, which is created as shown in Fig. 7 by having four sections separated at their distal end, but joined at their proximal end at neck 25. Thus, with no radial pressure exerted thereon, the knobs 24 assume an expanded diameter approximately equivalent to the diameter of the guide pins 23.

**[0057]** However, under the force of radial pressure, for example exerted by a narrowing diameter, the four sections press together and thereby assume a contracted diameter that is smaller than the expanded diameter. Of course, the knobs 24 could be configured in other ways as one of skill in the art should appreciate, which would also impart an expanded and contracted diameter thereto based on the presence of an outside radial force. It is important to note that the sectioned distal end of the knobs 24 are rounded and tapered while their proximal end connected to the necks 25 is not. This configuration in conjunction with that of the proximal end of the female portion 30 produces the primary locking mechanism of this embodiment as explained in more detail below.

**[0058]** From the bottom view in Fig. 6, a snap groove 28 can be seen, which is configured to receive the snap-fit interface 46 of the arm 44. From the top view in Fig. 7, fluid passage opening 29 can be seen through the distal end of the plunger 22, where fluid flows to the female portion 30. The plunger 22 has an O-ring around its distal end to provide leak-resistance. Fluid passage 27 fluidly connects fluid passage opening 29 with an opening in the extension leg tubing connector 26 (*see* Fig. 10). In both views, a finger rest 21 can be seen on the proximal end of the male portion 20 to

facilitate manual collapse of the male portion 20 into the female portion 30 by the clinician.

**[0059]** In Figs. 8 and 9, the female portion 30 is shown from a proximal (Fig. 8) and a distal (Fig. 9) viewpoint. The female portion 30 contains a plunger receptacle 32 and guide pin receptacles 34, sized to slidably receive the plunger 22 and guide pins 23 of the male portion 20 through a proximal end thereof. At a distal end of the female portion 30, a finger rest 31 is positioned, similar to finger rest 21 of the male portion 20, to facilitate collapse. From the distal viewpoint, locking chambers 36 can be seen that are configured to receive the knobs 24 of the guide pins 23 so that subsequent movement of the guide pins 23 is substantially prevented. The locking chambers 36 have a diameter equivalent to the guide pin receptacles 34, but include a narrowed region at the proximal end thereof to force the knobs 24 of the male portion 20 into their contracted diameter. After the knobs 24 move distal to the narrowed region and into the locking chambers 36, the knobs 24 resume their expanded diameter (due to the removal of pressure thereon) and are thereby "trapped" in the locking chamber as the narrowed region prevents proximal movement thereof due to the non-tapered configuration of the proximal end of the knobs 24.

**[0060]** Also shown in Fig. 9 is a needle mounting region 35, where a proximal end of the needle 86 (*see* Fig. 12) is held, and which enables fluid connection of the proximal end of the needle 86 to the plunger receptacle 32. While the mounting region 35 is shown as an arched area sized to frictionally hold the proximal end of the needle 86, which is angularly positioned relative to the needle shank 84, certainly many other configurations are possible, depending on the size and type of needle employed, which would equally be within the scope of the present invention. A mechanical interlock 37 is positioned on the proximal end of the female portion 30 for releasable connection to a recess on the base 40. The interlock 37 snaps into place when the assembly 10 is in the insertion position to prevent accidental movement of the assembly 10 during fluid delivery to a vascular access port. When it is desired to move the assembly into the protection position, the interlock 37 can be manually moved out of the recess. Of course, it should be appreciated that numerous types of releasable mechanisms would equally be desirable and are therefore contemplated to be within the scope of the present invention, including an embodiment wherein the

recess was positioned on the female portion 30 and the mechanical interlock was positioned on the base 40.

**[0061]** Turning now to Figs. 10-11, the assembly 10 is shown in the insertion and protection positions with the body shown in cross-section to illustrate the action of the plunger 22 and the guide pins 23. Initially, in the insertion position, the male portion 20 is in an uncollapsed state with respect to the female portion 30 so that fluid passing through the extension leg tubing 26, into the fluid passage 27 and through the fluid passage opening 29 collects in the plunger receptacle 32 before flowing into the proximal end of the needle 86. As the assembly 10 is moved from the insertion position to the protection position, the plunger 22 and guide pins 23 of the male portion 20 are moved through the respective receptacles 32 and 34 of the female portion 30 as shown in Fig. 11. As explained above, when the knobs 24 on the distal ends of the guide pins 23 pass over the narrowed region of the locking chambers 36, the knobs 24 are prevented from moving proximally back into the guide pin receptacles 34, thereby providing a primary locking mechanism for the assembly 10.

**[0062]** A use of the assembly 10 will be explained with reference to Figs. 12 and 13, which show a side cross-sectional view of the assembly 10. The fully assembled assembly 10 is prepared for insertion into a vascular access port by first removing a protective sleeve over the needle (not shown). The exact location of the vascular access port and, in particular, the septum through which the needle of the assembly 10 is to be placed is identified by the clinician and by grasping the assembly 10 on either side thereof in the insertion position, the needle is pressed through the patient's skin and into the septum of the vascular access port. At this time, the contact patch 42 should be flat against the patient's skin and optionally can be secured thereto by utilizing tape or other adhesive. Extension leg tubing, which has previously been connected to the extension leg tubing connector 26 (or alternatively is attached following securing the lower portion to the patient's skin), is attached to a fluid source, which pumps fluid in the form of a drug or medicine through the extension leg tubing, into the fluid passage 27, through the plunger receptacle 32 and into the proximal end of the needle 86, through the needle 80 and into the vascular access port (not shown).



**[0063]** When fluid delivery has been completed, the clinician clamps the extension leg tubing, removes the tape or adhesive (if any), unlocks the mechanical interlock 37 from the recess in the base 40, places the fingers of one hand on the contact patch 42 and with the second hand squeezes the male portion 20 and female portion 30 together, utilizing respective finger rests 21 and 31. By securing the needle assembly 10 with one hand in contact with the contact patch, stability of the assembly 10 is ensured, which is particularly useful should the needle 80 become stuck or otherwise prove difficult to remove from the vascular access port. As mentioned above, this occurrence often times results in accidental needle sticks, which are prevented through the stable configuration of the described embodiment.

**[0064]** The squeezing together of the body causes simultaneous action in separate parts of the assembly 10. With respect to the base 40, as the male portion 20 of the body moves toward the female portion 30, the arm 44 is forced in an upward direction, which in turn carries the body upward, which moves the needle up and out of the vascular access port. With respect to the fluid in the body, as the male portion 20 of the body moves toward the female portion 30, the plunger 22 expunges the fluid within the plunger receptacle 32 through the needle 80 as the needle is moving out of the vascular access port. This action creates a positive flush whereby the volume of fluid being expunged simultaneously replaces the volume of the needle in the reservoir of the vascular access port so that a negative pressure in the vascular access port is averted. Ideally, the volume of the infusion fluid contained in the body would be greater than the volume of the needle so that the infusion volume to the port can be manipulated by changing the geometry of the arm 44. Also, typically the fluid flow rate from the body during the positive flushing action is greater than the normal fluid flow rate through the assembly in the insertion position.

**[0065]** With respect to the body, the squeezing together of the male portion 20 and the female portion 30 eventually causes the knobs 24 on the distal ends of the guide pins 23 to move into the locking chambers 36 thereby preventing further relative movement of the male and female portions. At the same time, the needle tip 82 passes through the distal opening 62 and into the needle housing shaft 66 where it is biased therein, prevented from distal movement by ledge 64. Thus, in the protection

position shown in Fig. 13, the assembly 10 is held in place by both a primary and secondary locking mechanism.

[0066] Figs. 14-17 illustrate another embodiment of the present invention. Winged assembly 100 contains three primary components: a needle 80, a needle housing, having an upper portion 110 and a lower portion 120, and a collapsible reservoir 150. The winged assembly 100 is shown in Fig. 14 in the insertion position and in Fig. 15 in the protection position. Referring to Fig. 16, the upper portion 110 of the housing is shown without the lower portion 120 attached. The needle 80 is attached to the front 114 of the upper portion through an opening or groove therein with the use of adhesives, friction fit, mechanical means or some combination thereof. Needle 80 may or may not have a proximal end which is angularly positioned with respect to the shank thereof. The proximal end of the needle is fluidly connected to the collapsible reservoir 150, which is disposed within the upper portion 110 of the housing. The collapsible reservoir 150 is configured to be collapsible in the presence of externally exerted force and is so positioned within the upper portion 110 of the housing. In particular, the collapsible reservoir 150 is adhered to only a single horizontal surface of the upper portion 110 so that the vertical surfaces of the collapsible reservoir are allowed to collapse in a uniform manner.

[0067] At the rear of the upper portion 110, a connector (not shown) is attached to enable connection to an extension tubing, the connector being in fluid communication with the collapsible reservoir 150. Across the top region of the upper portion 110, opposing wings 116 span to facilitate grasping and movement of the winged assembly 100. At the base of the upper portion 110, below the attached collapsible reservoir 150, a portion containing four grooves 113 is positioned, which permit a snap-fit of the lower portion 120 therein, positive locking the lower portion 120 to the upper portion 110. Attached to the bottom of the upper portion 110 is a stiffening rib 112, which acts to provide structural support to the winged assembly 100 and which releasably locks the winged assembly 100 in the insertion position by snapping into grooves 142 in the lower portion 120 (*see* Fig. 17).

[0068] Referring now to Fig. 17, the lower portion 120 is shown in isolation. The lower portion contains four panels that function through the use of living hinges

therebetween. The four panels are really two panels that mirror each other, separated by a needle housing 140 and grooves 142 that interlock with the stiffening rib 112. The outer panels 122, 124 contain rods 132 that snap-fit within the grooves 113. Between the rods 132 are extensions 130, which press against the collapsible reservoir 150 as the winged assembly moves from an insertion position to a protection position, thereby collapsing the collapsible reservoir 150 and expunging the fluid therefrom. Below the extensions are windows 134 that align with protrusions 136 on adjacent inner panels 126, 128. On the sides of the outer panels 122, 124 are recesses 131, which are sized to receive locking sections 133 on the adjacent inner panels 126, 128 to releasably lock the winged assembly 100 in the insertion position.

**[0069]** In a separate locking mechanism, the protrusions 136 of the inner panels 126, 128 mate with one another in the protection position through the complementary button/detent thereon (Fig 17 shows button 138 on protrusion 136, whereas Fig. 14 reveals the detent on the opposing protrusion 136) to permanently lock the winged assembly 100 in the protection position. Positioned adjacent the protrusions 136 are apertures 137 to allow full movement of the opposing protrusion 136 as the winged assembly 100 is moved into the protection position. While the protrusions 136 are illustrated as being offset from one another for mating purposes, it is envisioned that alternate embodiments would have other types of interlocking mechanisms that were not so offset and rather provided a positive locking feature by snapping together or otherwise permanently locking. Between the inner panels 126, 128 is a needle housing 140 that operates similarly to the needle housing 60 as explained above to prevent movement of the needle in a distal direction once the needle tip has passed into the needle shaft and is biased to its normal position.

**[0070]** Referring back to Figs. 14 and 15, the operation of the winged assembly 100 is initiated by the clinician by removing a protective needle sheath (not shown) from the needle and grasping the wings 116 with one hand as the winged assembly 100 is locked in the insertion position (Fig. 14). The clinician squeezes the wings 116 together to grip the winged assembly 100 and presses the needle 80 into a patient's skin and into an implanted vascular access port. The inner panels 126, 128 of the lower portion 120, lying substantially flat against the patient's skin, can then be secured thereto for delivery of the fluid by applying tape or other type of adhesive to

the lower portion 120 (for example, taping over the outer panels 122, 124). An extension tubing set, previously attached to the connector at the rear 114 of the upper portion 110 (or alternatively attached following securing the lower portion to the patient's skin), is itself connected to a fluid source, which pumps fluid through the connector, into the collapsible reservoir 150, through the needle 80 and into the vascular access port.

**[0071]** When delivery of the fluid is completed, the extension tubing is clamped and the tape or adhesive (if any) is removed. The clinician with one hand squeezes the lower portion 120 together, causing the locking sections 133 to disengage from the recesses 131 and the inner panels 126, 128 to align longitudinally with the outer panels 122, 124 as shown in Fig. 15. As the panels straighten with respect to one another, the needle is withdrawn from the vascular access port. It is noted that this configuration prevents accidental needle sticks due to the fact that the needle is never exposed outside of the body. As soon as the needle exits the skin, it is enveloped by the lower portion 120.

**[0072]** Simultaneously to the needle withdrawal, the extensions 130 on the outer panels 122, 124 press into the collapsible reservoir 150 causing it to collapse and expunge fluid therein through the needle 80 and into the vascular access port as the needle moves outward. This simultaneous action produces a positive flush whereby the volume of fluid being expunged simultaneously replaces the volume of the needle in the reservoir of the vascular access port so that a negative pressure in the vascular access port is averted. As the panels straighten, the protrusions 136 press together, the complimentary button/detent 138 positively and permanently locking together. At the same time, the needle tip 82 passes through a distal opening of the needle housing 140 and into a needle housing shaft where it is biased therein, prevented from distal movement by a ledge. Thus, in the protection position shown in Fig. 15, the winged assembly 100 is held in place by both a primary and secondary locking mechanism.

**[0073]** In another embodiment of the present invention, illustrated by Figs. 18-24, a balloon and compression plate combination acts as a mechanism by which a positive flush is created. Referring to Figs. 18-21, various views of a needle assembly

200 are illustrated. Needle assembly 200 includes a wing base 210 onto which is mounted a handle 220, having separate left 222 and right 224 halves that interlock with one another when assembled. Below the wing base 210 is a support structure 240, which has an opening 248 for needle 80. As best seen in Fig. 20, both the handle 220 and the wing base 210 have contoured surfaces for finger placements along with respective ridges 226 and 218 for gripping. The contoured surface 216 of wing base 210 comprises a raised portion at each opposing end. These features provide ease of use and protect against slippage. Needle 80 is fluidly connected to tail 252, which is configured for connection to extension leg tubing (not shown).

[0074] An exploded view of needle assembly 200 is illustrated in Fig. 22, showing the separate parts prior to assembly. The support structure 240 is assembled through the bottom of the wing base 210 through four openings 212, each of which accommodates a leg 242 of the support structure. The legs 242 are each configured with a first notched section 244 and a second notched section 246, which serve different purposes as will be explained more fully below. Support structure 240 and wing base 210 each contain an opening 248, 214 that are aligned for receiving a protection sleeve 230 and the needle 80. The protection sleeve 230 is made of a material thick and/or tough enough so that the needle 80 cannot penetrate through in the protection position, such as nylon, though certainly a number of materials are certainly possible. The protection sleeve 230 has a proximal portion 232, having an increased radius for bonding between the support structure 240 and the wing base 210. The protection sleeve 230 also has a distal portion 234 with a tapered configuration for ease of insertion within the body of a patient.

[0075] The left 222 and right 224 halves of handle 220 snap together on top of the wing base 210, enclosing therein a proximal end 86 of the needle 80 around which a balloon extension 250 is fitted. The balloon extension 250 holds a volume of fluid for the positive flushing feature as described in detail below. Positioned above the balloon extension 250 is a compression plate 260, which acts to press the fluid out of the balloon extension 250 as the needle assembly is moved from the insertion position to the protection position. It should be appreciated that although a balloon extension is illustrated, many possibilities exist for a collapsible or compressible member that could contain within it a volume of fluid and which would collapse upon pressure

from an external source. In addition, it should be noted that balloon extension 250 could be made of various materials (for example, silicone or polyurethane), which have the desired properties of ruggedness, attachability and collapsibility so that any problems associated with bursting or loosening from the needle are avoided.

[0076] Fig. 23 illustrates, in cross-section, the needle assembly 200 in the insertion position. With reference to this view, the assembly of the needle assembly 200 will be explained, although certainly other manners of assembly are also possible with respect to chemical or mechanical bonds. From this view, the interlocking features of the handle 220 can clearly be seen. As shown in Fig. 22, the right half 224 of the handle 220 has holes 225 in the upper corners thereof to receive pins 227 positioned on the upper corners of the left half of the handle 220, although certainly the holes 225 and pins 227 could be reversed. The handle 220 also includes interlocking tabs 229 positioned on the sides of each half 222, 224 near the lower corners thereof, which are received in corresponding slots on the opposing half. These interlocking features are intended to be one-way or permanent so that convenience of manufacture can be maintained without sacrificing safety, although it is possible that releasable locks would be desired in certain situations. Moreover, while interlocking features have been specifically described, it should be appreciated that various possibilities exist to lock a handle around certain internal parts that would equally be within the scope of the present invention.

[0077] Because of the separate halves of the handle 220, assembly of the compression plate 260 can be accomplished without any special tools as the plate 260 is merely slid into the notched sections 248 on each of the four legs 242 of the support structure 240 over the balloon extension 250 after it has been positioned against the lower portion of the handle 220. It should be noted that the handle 220 envelopes the compression plate 260 and the balloon extension 250, but is not attached to the wing base 210. The support structure 240 is chemically bonded to the bottom of the wing base 210 to hold the aforementioned components in place with respect to one another. The balloon extension 250 is bonded to the proximal end 84 of the needle 80 and has a tail 252 extending out of an opening in the back of the handle 220.

**[0078]** Referring now to Fig. 24, the needle assembly 220 is illustrated in a protection position, showing the interaction between various parts thereof as the needle 80 is withdrawn from a vascular access port (not shown). Similar to embodiments described above, the needle assembly 200 in the insertion position lies on top of a patient's skin, the needle 80 inserted into a vascular access port implanted below the patient's skin. The wing base 210 with the support structure 240 lie flush against the patient's skin. Upon delivery of drug or other medicant to the port, the physician places the index finger and thumb of one hand onto the wing base 210, pressing it against the patient's skin, while grasping the handle 220 with the free hand and pulling it in an upward direction. The handle 220 slides along the legs 242, which remain stationary, being bonded to the wing base 210. The legs 242 are tapered, causing them to bend as the handle 220 is pulled upward, which creates resistance. The resistance is useful in preventing a withdraw that is too quick, which could potentially lead to problems.

**[0079]** The upward action of the handle 220 removes the needle 80 from the vascular access port while simultaneously flushing fluid contained within the balloon extension 250 through the distal needle tip 82, thereby replacing the volume of the needle in the reservoir of the vascular access port with the fluid contained within the balloon extension 250 so that a negative pressure in the vascular access port is averted. A positive flush is created, as shown in Fig. 24, by the action of the compression plate 260 against the balloon extension 250. Specifically, as the handle 220 is pulled upward with respect to the wing base 210, the balloon extension 250, which lies between the base of the handle 220 and the compression plate 260, is compressed as the compression plate 260 remains stationary with respect to the handle 220. More particularly, the compression plate 260 is held in place by the legs of the support structure 240 and is not attached to the handle 220, so that movement of the handle 220 causes the compression of the balloon extension 250.

**[0080]** It should be noted that while a compression plate is described, the present invention would also encompass an embodiment where the compression of the compressible member, such as balloon extension 250, takes place via configurations of the internal portions of the handle or via configurations of the support structure that reaches into the handle. Alternatively, other housing

configurations could be imagined within the scope of the present invention that would cause compression of the compressible member upon relative movement between the housing and a base.

**[0081]** Simultaneous to the positive flush taking place, the needle assembly 200 locks into a safety position in two respects. First, the needle tip 82 enters the protection sleeve 230 as the handle 220 is moved upward with respect to the wing base 210. When the handle 220 reaches the position of the first notched section 246 of the legs 242 of the support section 240, the lower portion of the handle 220 locks into place, snapping audibly in the process to provide a positive indication to the physician to cease withdraw. This is the primary locking mechanism for needle assembly 200. Due to the locking interaction between the handle and the legs 242 of the support section 240, the balloon extension 250 is prevented from expanding upon release, which would cause backflow. At this locked position, the needle tip 82 is fully within the protection sleeve 230, the tip coming into contact with the inner surface thereof, which prevents movement out of the sleeve. This secondary locking mechanism ensures that the needle tip 82 is completely covered by the protection sleeve 230 to avoid accidental needle sticks.

**[0082]** The present invention has been described above in terms of certain preferred embodiments so that an understanding of the present invention can be conveyed. However, there are many alternative arrangements for a positive flush mechanism not specifically described herein but with which the present invention is applicable. Although specific features have been provided, the safety needle with positive flush device of the present invention would equally be embodied by other configurations not specifically recited herein. The scope of the present invention should therefore not be limited by the embodiments illustrated, but rather it should be understood that the present invention has wide applicability with respect to a positive flush system generally. All modifications, variations, or equivalent elements and implementations that are within the scope of the appended claims should therefore be considered within the scope of the invention.



## CLAIMS

1. A safety needle assembly for use with a subcutaneously implanted vascular access port, comprising:
  - a needle having a proximal end and a distal end;
  - a body attached to and in fluid communication with the proximal end of the needle; and
  - a base attached to the body;wherein movement of the needle assembly from an insertion position to a protection position expunges fluid from the body through the distal end of the needle, creating a positive flush.
2. The needle assembly according to claim 1, wherein the proximal end of the needle is angularly positioned relative to the distal end of the needle.
3. The needle device according to claim 1, wherein said distal end of said needle has a non-coring configuration.
4. The needle assembly according to claim 1, wherein said base comprises a needle housing that surrounds the distal end of said needle and prevents movement thereof in a distal direction when the needle assembly is in the protection position.
5. The needle assembly according to claim 1, wherein said base comprises a contact patch that maintains contact with a patient's skin during movement from the insertion position to the protection position.
6. The needle assembly according to claim 5, wherein said contact patch conforms to the contour of the patient.

7. The needle assembly according to claim 5, wherein said base further comprises an arm and a hinge, being respectively attached to an opposite end of said body.

8. The needle assembly according to claim 1, wherein said body comprises a female portion and a male portion that collapse together upon movement from the insertion position to the protection position.

9. The needle assembly according to claim 8, wherein said male portion comprises a plunger element that expunges fluid from said female member when the needle assembly is moved from the insertion position to the protection position.

10. The needle assembly according to claim 8, wherein said male portion comprises at least one guide pin having at its distal end a locking portion.

11. The needle assembly according to claim 10, wherein said female portion comprises a guide pin receptacle having a locking chamber that receives said locking portion of said guide pin, thereby preventing relative movement of said male portion.

12. The needle assembly according to claim 11, wherein said locking portion comprises an expanded diameter and a contracted diameter.

13. The needle assembly according to claim 12, wherein said locking chamber comprises a narrowed region that exerts external pressure on said locking portion, forcing said locking portion into its contracted diameter.

14. The needle assembly according to claim 8, wherein said female portion comprises a releasable interlock member that releasably locks said body to said base when the needle assembly is in the insertion position.

15. The needle assembly according to claim 8, wherein said base comprises a contact patch that maintains contact with a patient's skin during movement from the insertion position to the protection position.

16. The needle assembly according to claim 15, wherein said contact patch comprises needle housing that surrounds the distal end of said needle and prevents movement thereof in a distal direction when the needle assembly is in the protection position.

17. The needle assembly according to claim 16, wherein said base further comprises an arm and a hinge, said arm being attached at one end to said male portion and at an opposite end to said first component, said hinge being attached at one end to said arm and at an opposite end to said female member.

18. A needle device for use with a subcutaneously implanted vascular access port, comprising:

a needle having a proximal end and a distal end;

a housing attached to said proximal end of said needle, comprising a lower portion and an upper portion, said lower portion being movable from an insertion position to a protection position, said upper portion being graspable to facilitate positioning of said needle device; and

a collapsible reservoir disposed between said upper and lower portions of said housing and in fluid communication with said fluid flow path of said needle.

19. The needle device according to claim 18, wherein said proximal end of said needle is angularly positioned relative to said distal end.

20. The needle device according to claim 18, wherein said distal end of said needle has a non-coring configuration.

21. The needle device according to claim 18, wherein said lower portion comprises at least one extension positioned adjacent said collapsible reservoir, wherein said extension engages said collapsible reservoir when said lower portion is moved from the insertion position to the protection position, thereby expunging fluid from said collapsible reservoir.

22. The needle device according to claim 18, wherein said lower portion comprises a releasable locking mechanism that releasably locks said lower portion in the insertion position.

23. The needle device according to claim 18, wherein said lower portion comprises a permanent locking mechanism for permanently locking said lower portion in the protection position.

24. The needle device according to claim 18, wherein said lower portion comprises an integral hinged assembly having a plurality of connected sections.

25. The needle device according to claim 24, wherein said hinged assembly comprises at least one extension positioned adjacent said collapsible reservoir, wherein said extension engages said collapsible reservoir when said lower portion is moved from the insertion position to the protection position, thereby expunging fluid from said collapsible reservoir.

26. The needle device according to claim 24, wherein said hinged assembly comprises a releasable locking mechanism that releasably locks said lower portion in the insertion position.

27. The needle device according to claim 26, wherein said releasable locking mechanism comprises a first locking element positioned on the interior of at least one of said sections in alignment with a corresponding second locking element positioned on an adjacent section when said lower portion is in the insertion position.

28. The needle device according to claim 24, wherein said hinged assembly comprises a permanent locking mechanism for permanently locking said lower portion in the protection position.

29. The needle device according to claim 28, wherein said permanent locking mechanism comprises two protrusions positioned on the interior adjacent inner sections, said protrusions being configured to lock together in the protection position.

30. The needle device according to claim 18, wherein said lower portion comprises an integral hinged assembly having four connected sections, wherein a first and fourth section are configured for attachment to said upper portion and wherein a second and third section are configured for locking engagement with one another when in the protection position.

31. The needle device according to claim 30, wherein said second and third section each have a protrusion on an interior thereof, wherein said protrusions on said second and third sections are configured for locking engagement when the needle device is in the protection position.

32. The needle device according to claim 31, wherein said first section has an opening in alignment with said protrusion on said second section for receipt therethrough when said lower portion is in the insertion position and wherein said fourth section has an opening in alignment with said protrusion on said third section for receipt therethrough when said lower portion is in the insertion position.

33. The needle device according to claim 30, wherein at least one of said first and fourth sections comprises a first locking element and wherein at least one of said second and third sections comprises a second locking element, said first and second locking elements being configured for releasably locking said lower portion in the insertion position.

34. The needle device according to claim 30, wherein said first and fourth sections each comprise an extension portion wherein said extension portions press against said collapsible reservoir when said lower portion is moved from said insertion position to said protection position.

35. A safety needle assembly, comprising:  
a needle having a proximal end and a distal end;  
a compressible member connected to a proximal end of said needle and  
in fluid communication therewith;  
a base having an opening for receiving said needle;  
a body surrounding said compressible member and movable with  
respect to said base;  
wherein movement of said needle assembly from an insertion position  
to a protection position expunges fluid from the compressible  
member through the distal end of the needle, creating a positive  
flush.

36. The needle assembly according to claim 35, wherein the proximal end of the needle is angularly positioned relative to the distal end of the needle.

37. The needle device according to claim 35, wherein said distal end of said needle has a non-coring configuration.

38. The needle device according to claim 35, wherein the compressible member comprises a balloon having a capacity to hold a volume of fluid.

39. The needle device according to claim 35, wherein said base is positioned under said body, said base comprising a winged member configured to lie substantially flat against a surface.

40. The needle device according to claim 39, wherein said winged member further comprises a contoured section.

41. The needle device according to claim 40, wherein said contoured section comprises gripping ridges.

42. The needle device according to claim 39, wherein said base further comprises a support structure.

43. The needle device according to claim 42, wherein said support structure has an extending portion that extends through said winged member and into said body.

44. The needle device according to claim 43, wherein said extending portion is configured for holding a compression member.

45. The needle device according to claim 44, wherein said compressible member is positioned between said compression member and said body.

46. The needle device according to claim 43, wherein said extending portion comprises a locking section, wherein movement to the protection position permanently locks the body to the extending portion.

47. The needle device according to claim 43, wherein said extending portion comprises a plurality of legs.

48. The needle device according to claim 47, wherein said legs are tapered.

49. The needle device according to claim 48, wherein said legs comprise a first notched section, configured to receive a portion of said body therein when said needle assembly is in the protection position.

50. The needle device according to claim 48, wherein said legs comprise a second notched section, configured to receive a compression member therein.

51. The needle device according to claim 35, wherein said body comprises separate halves that permanently lock together.

52. The needle device according to claim 35, wherein said body comprises a contoured outer surface.

53. The needle device according to claim 52, wherein said contoured outer surface comprises gripping ridges.



54. The needle device according to claim 35, further comprising a compression member, wherein movement from the insertion position to the protection position forces said compression member against said compressible member.

55. The needle device according to claim 35, further comprising a protection sleeve surrounding a portion of said needle, wherein a needle tip of said needle is uncovered by said protection sleeve when said needle assembly is in the insertion position and wherein said needle tip is covered by said protection sleeve when said needle assembly is in the protection position.

56. The needle device according to claim 55, wherein said needle tip is biased against movement out of said protection sleeve when said needle assembly is in said protection position.

57. A method of supplying fluid to a vascular access port, comprising:

providing a needle assembly comprising a needle and a positive flushing mechanism;

inserting said needle into said vascular access port;

delivering fluid to said vascular access port;

removing said needle from said vascular access port; wherein said positive flushing mechanism is engaged, sending a volume of fluid through said needle before said needle completely exits said port.

58. A method for preventing a negative pressure within a vascular access port upon removal of a needle therefrom, comprising:

activating a positive flushing mechanism comprising a fluid-holding member, wherein a volume of fluid is simultaneously released from said member through a needle tip of said needle when said needle tip is withdrawn from said vascular access port.

1/14

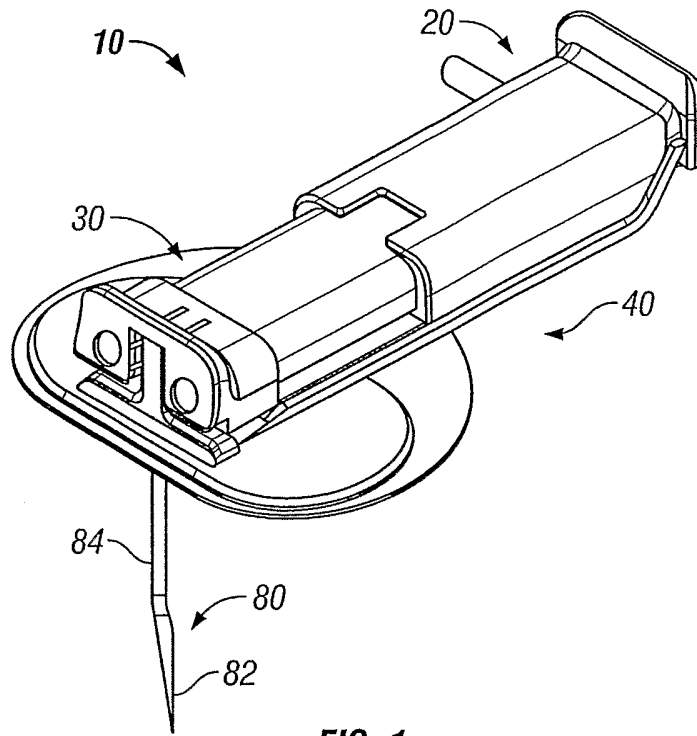

FIG. 1

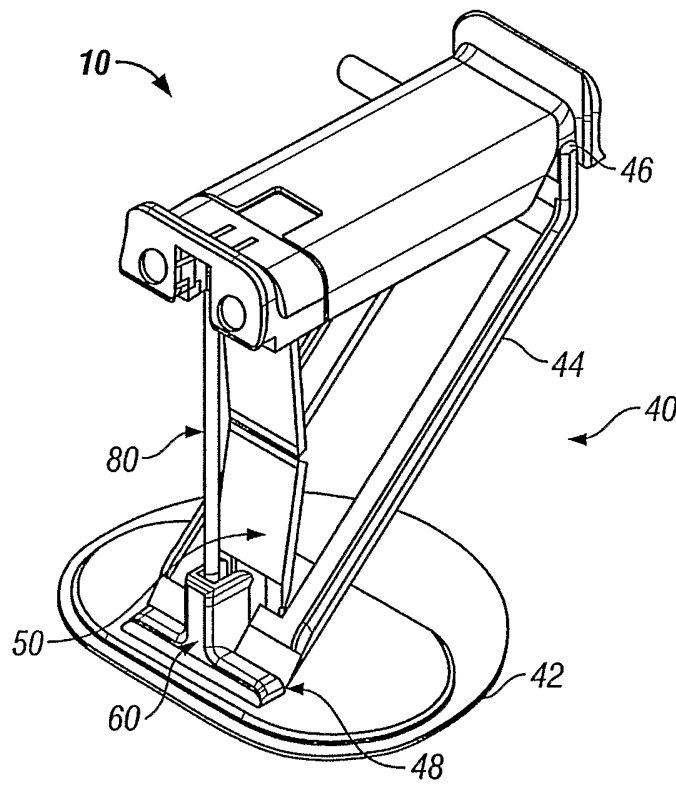

FIG. 2

2/14

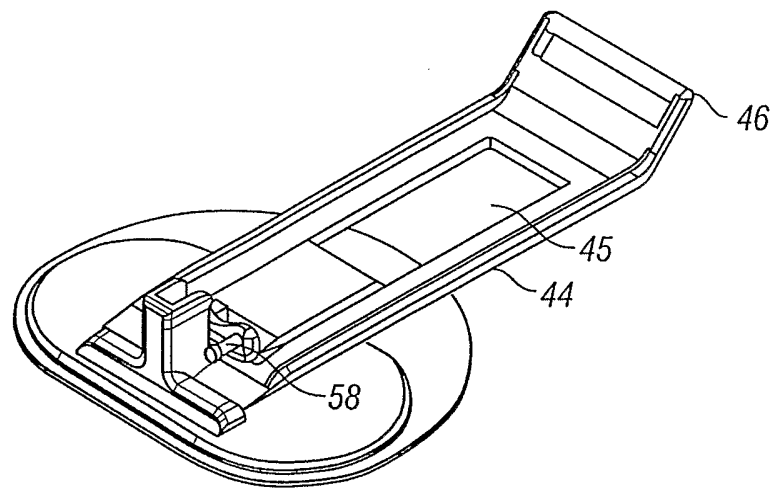

FIG. 3

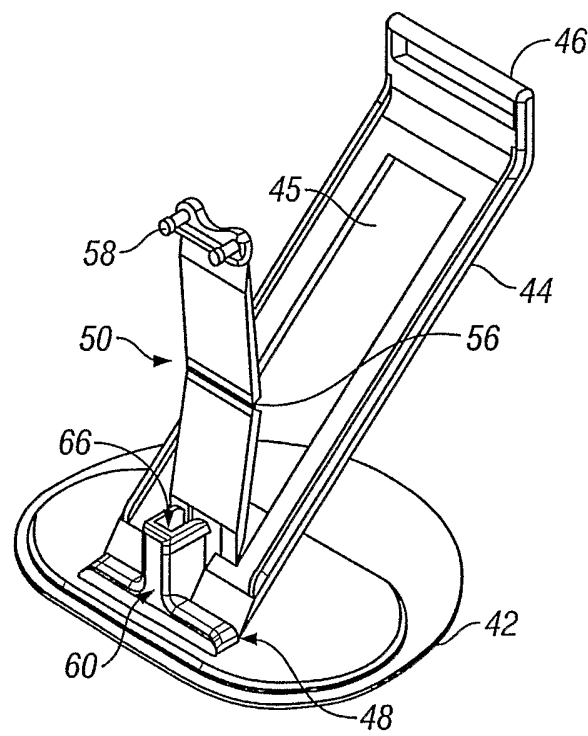
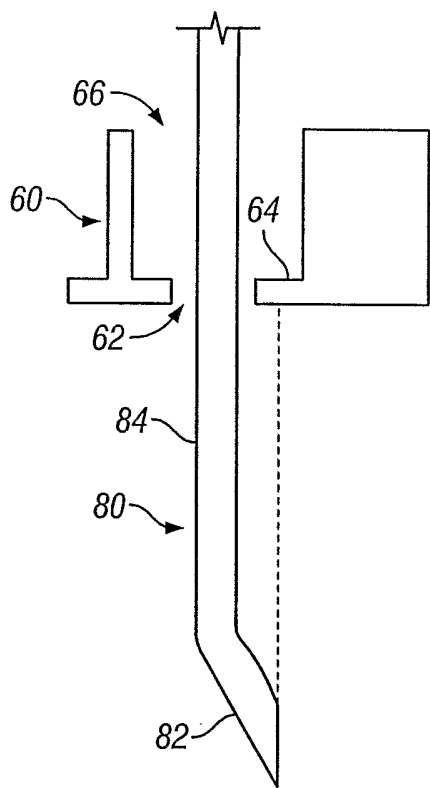
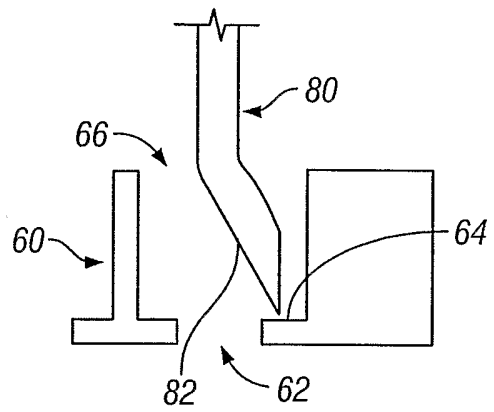

FIG. 4



**FIG. 5A**



**FIG. 5B**

4/14

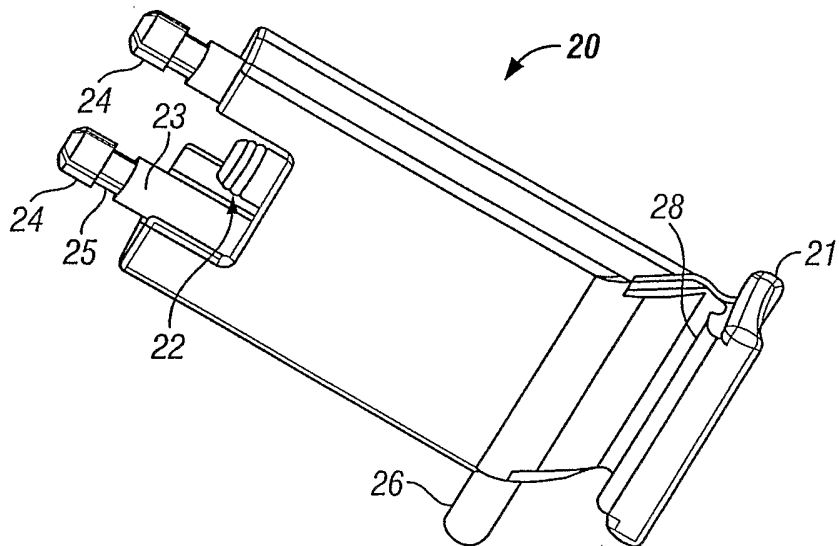

FIG. 6

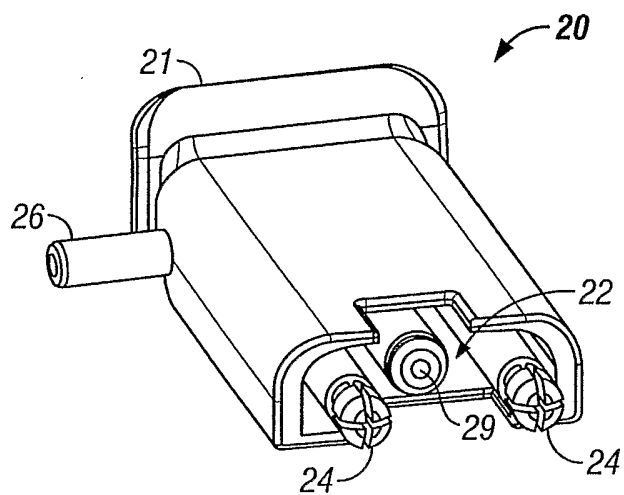

FIG. 7

5/14

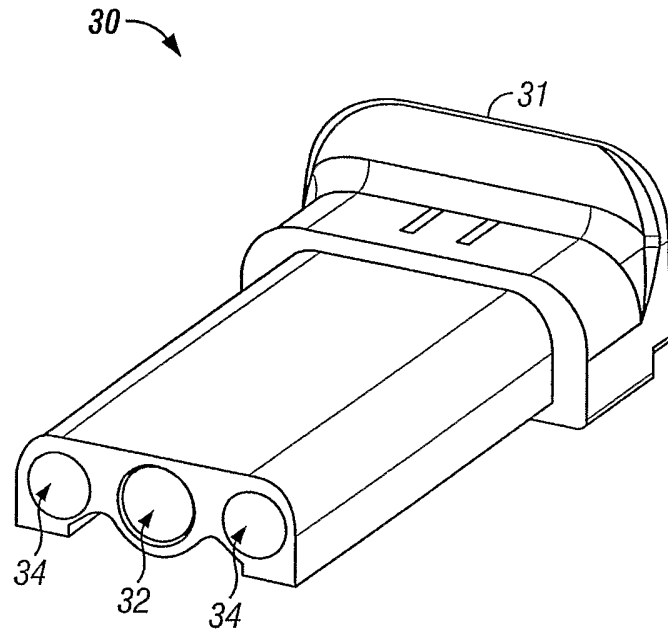

FIG. 8

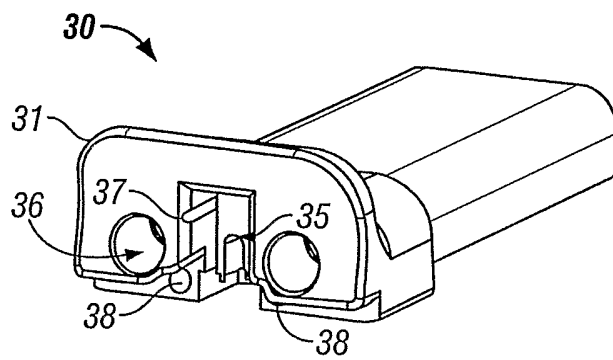

FIG. 9

6/14

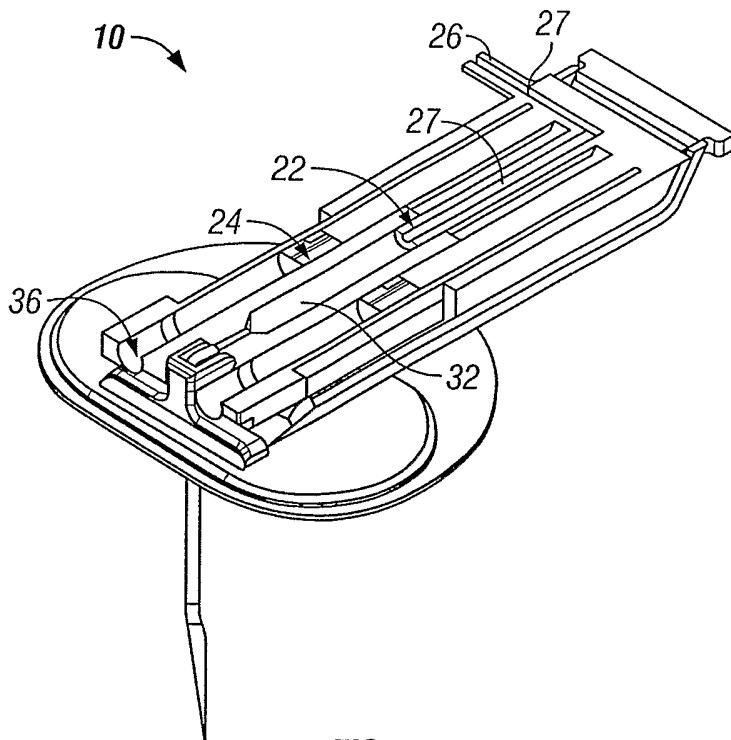

FIG. 10

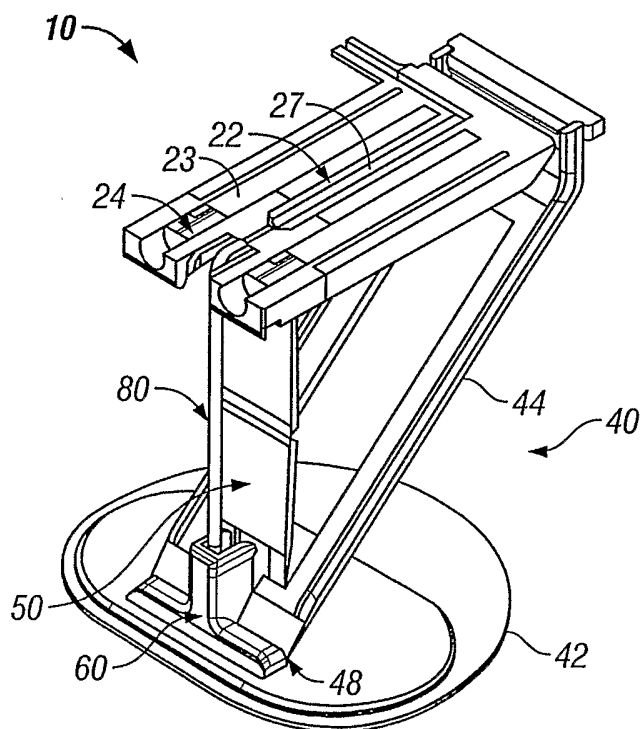

FIG. 11



7/14

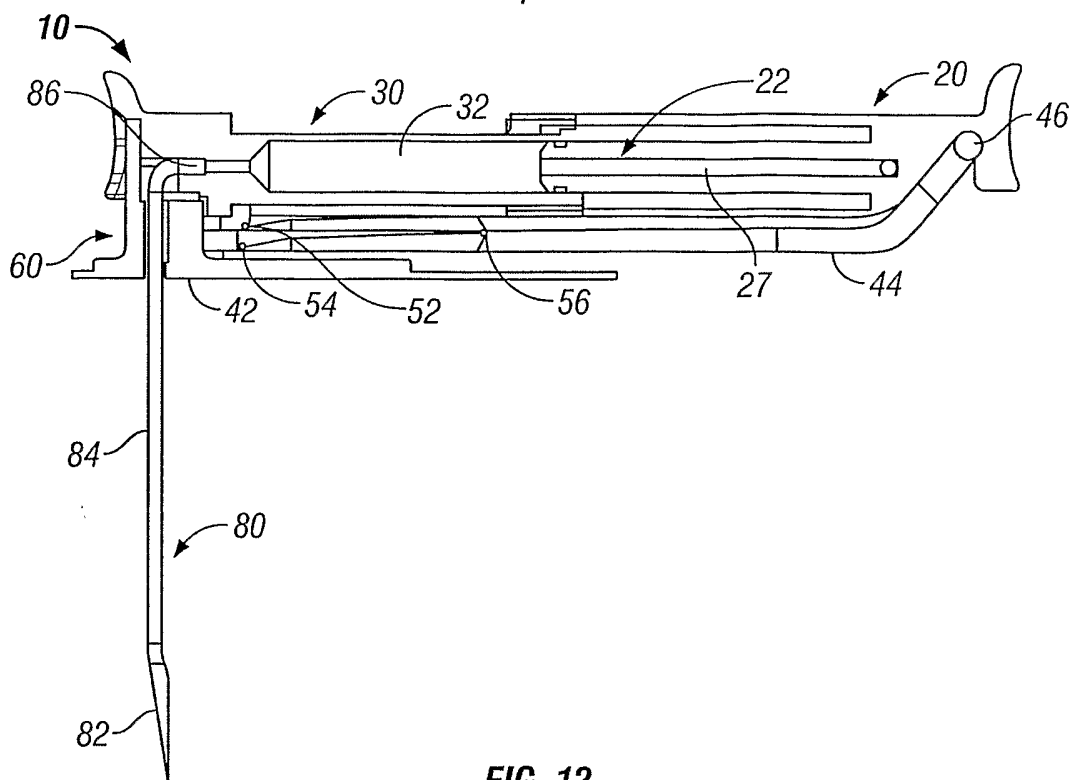

FIG. 12

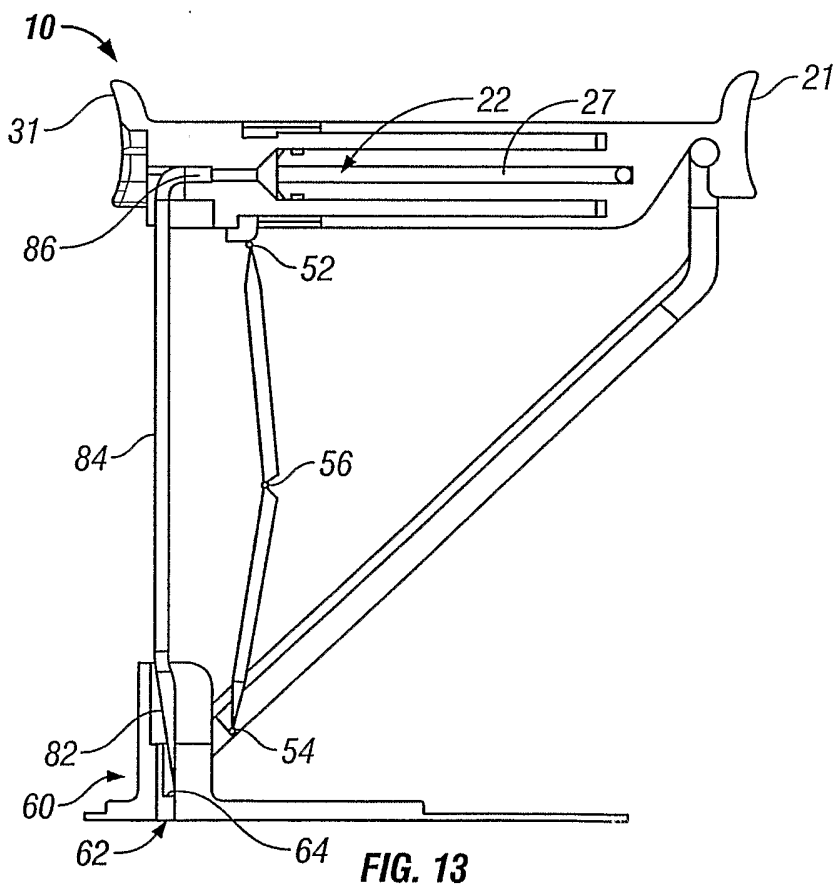

FIG. 13

8/14

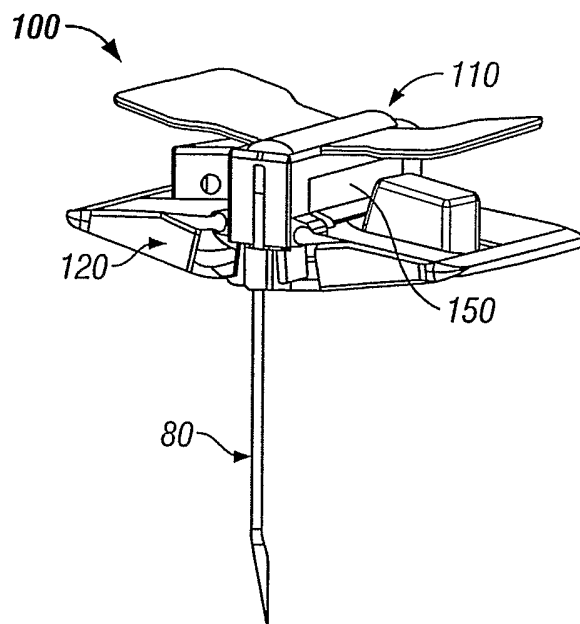

FIG. 14

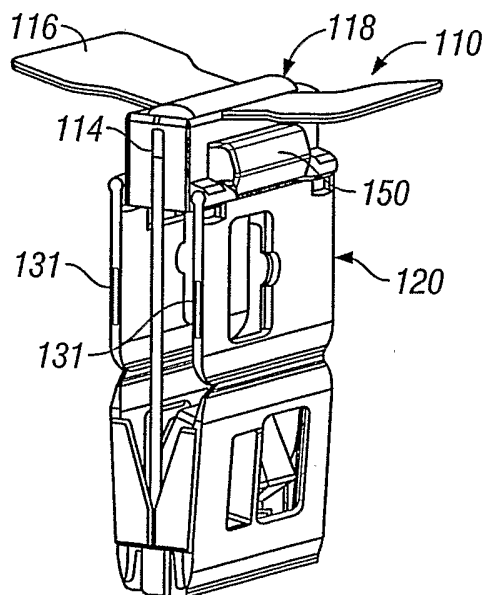

FIG. 15

9/14

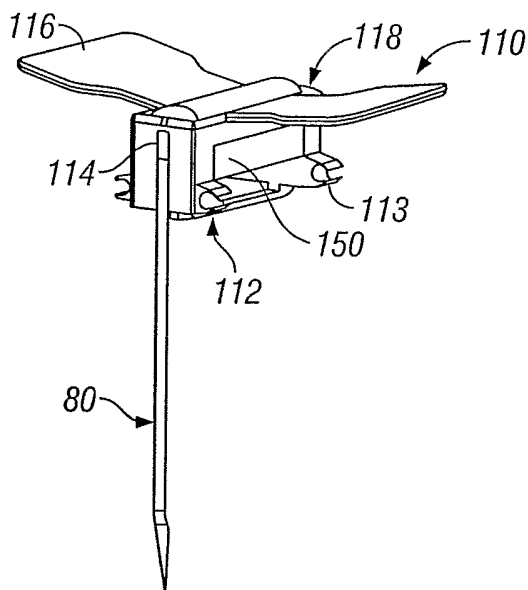

FIG. 16

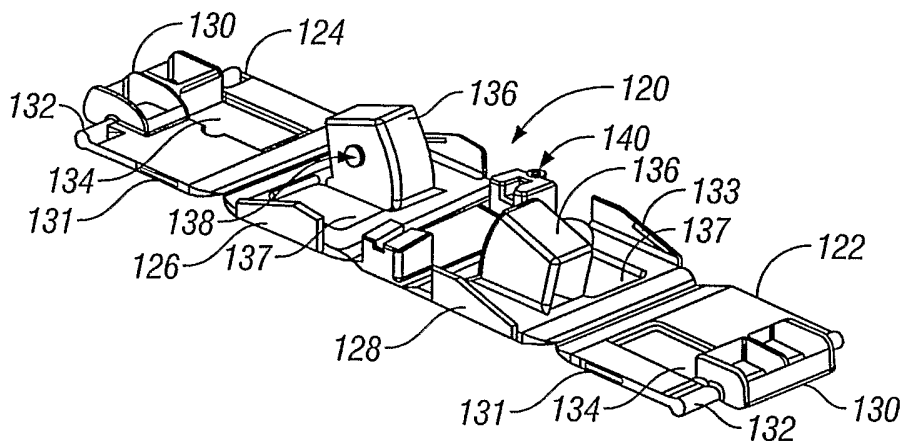

FIG. 17

10/14

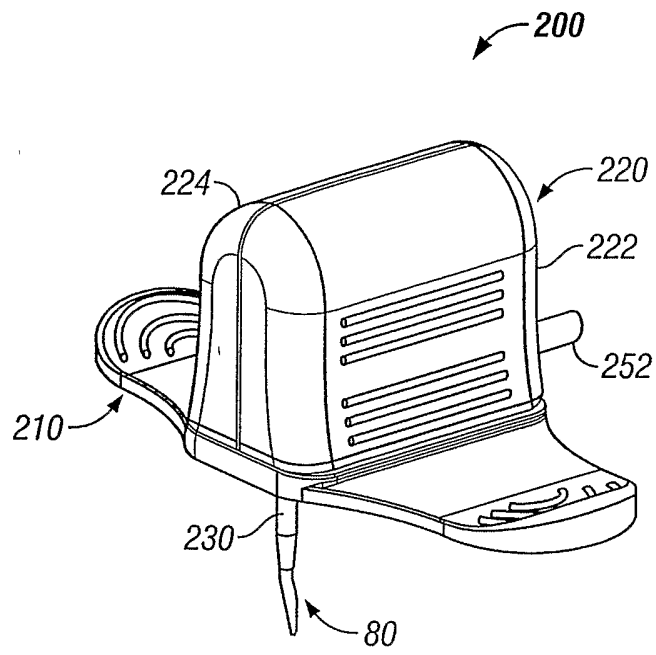

FIG. 18

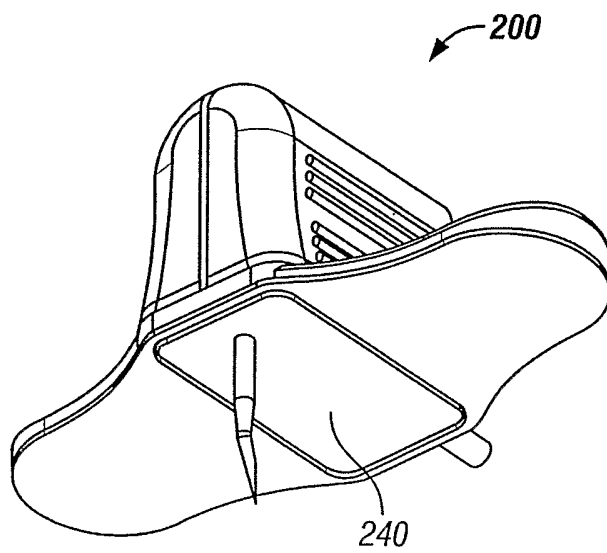

FIG. 19

11/14

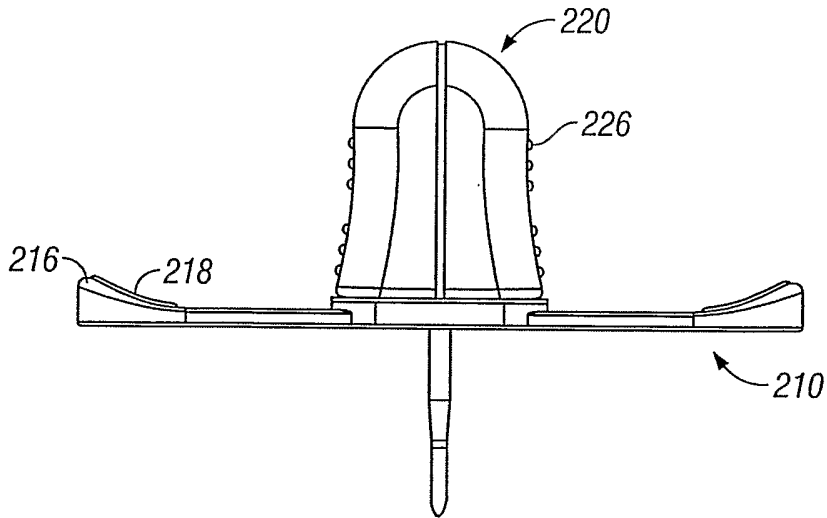

FIG. 20

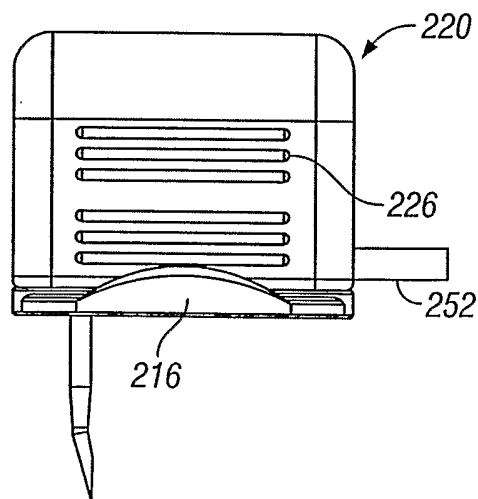

FIG. 21

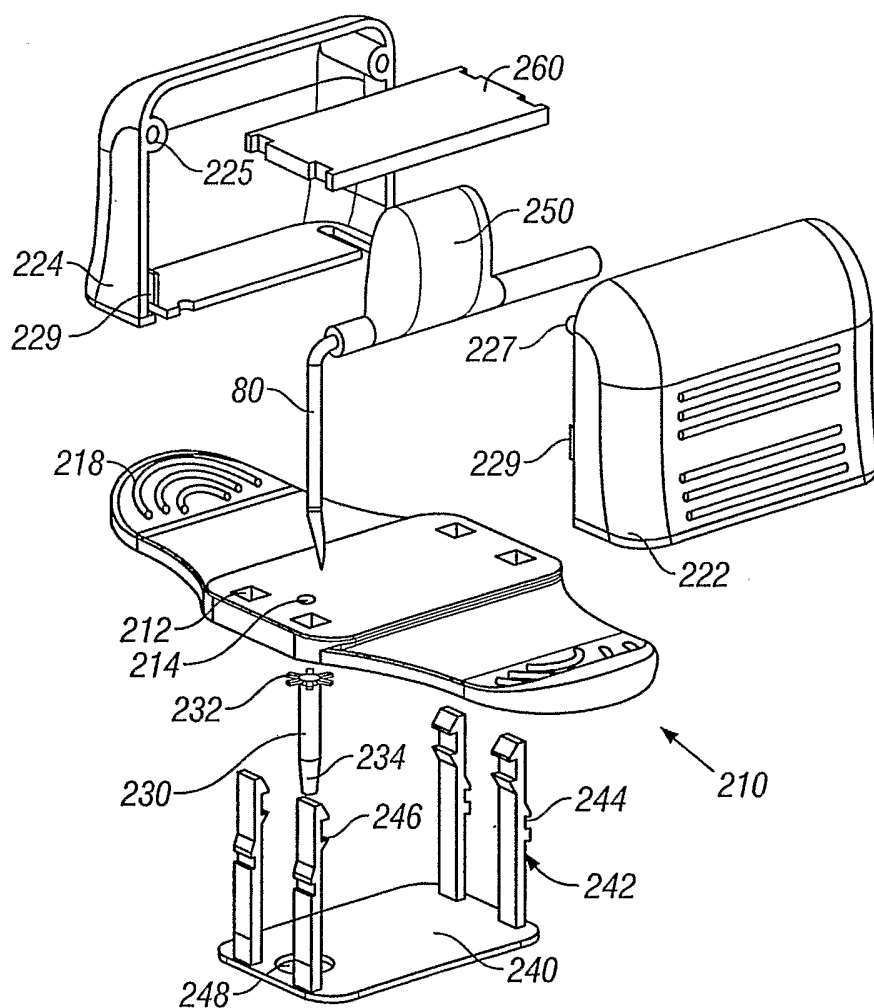

FIG. 22

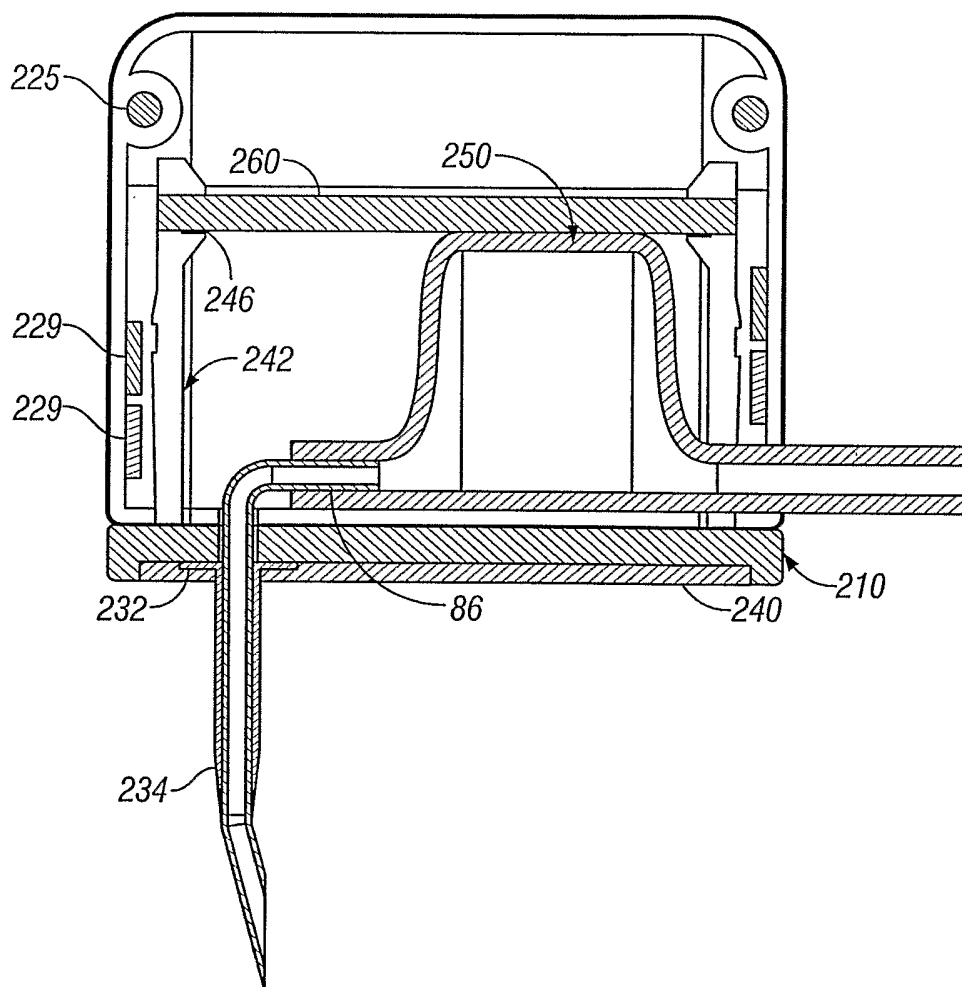

FIG. 23

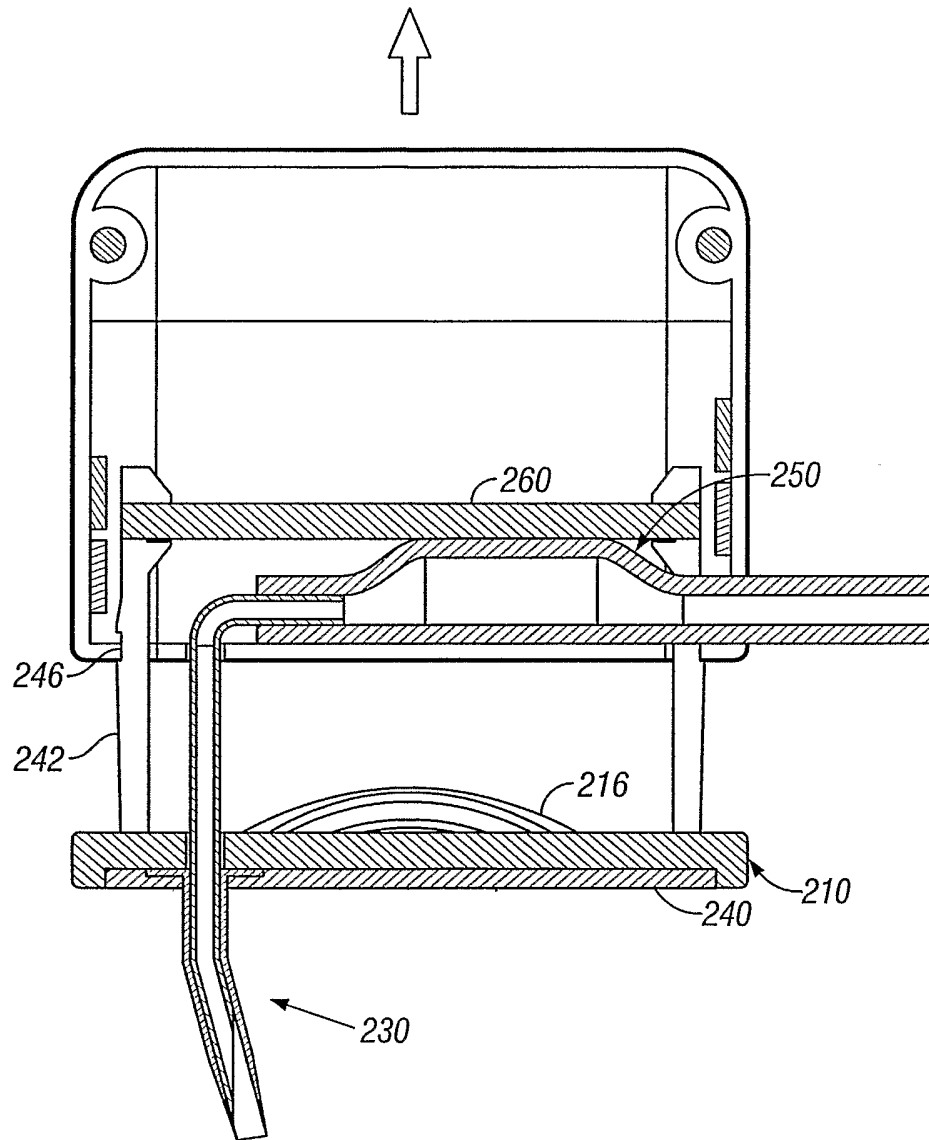

FIG. 24



INTERNATIONAL SEARCH REPORT

International Application No

PCT/US2004/022579

A. CLASSIFICATION OF SUBJECT MATTER

IPC 7 A61M5/158

According to International Patent Classification (IPC) or to both national classification and IPC

B. FIELDS SEARCHED

Minimum documentation searched (classification system followed by classification symbols)

IPC 7 A61M

Documentation searched other than minimum documentation to the extent that such documents are included in the fields searched

Electronic data base consulted during the international search (name of data base and, where practical, search terms used)

EPO-Internal

C. DOCUMENTS CONSIDERED TO BE RELEVANT

Category °	Citation of document, with indication, where appropriate, of the relevant passages	Relevant to claim No.
A	US 4 861 341 A (WOODBURN ROBERT T) 29 August 1989 (1989-08-29) abstract; figures 3-4B -----	1-17, 35-56
A	WO 02/04065 A (FANGROW THOMAS F JR ; ICU MEDICAL INC (US)) 17 January 2002 (2002-01-17) abstract; figures 10-13 -----	1-17, 35-56

Further documents are listed in the continuation of box C.

Patent family members are listed in annex.

° Special categories of cited documents :

- "A" document defining the general state of the art which is not considered to be of particular relevance
- "E" earlier document but published on or after the international filing date
- "L" document which may throw doubts on priority claim(s) or which is cited to establish the publication date of another citation or other special reason (as specified)
- "O" document referring to an oral disclosure, use, exhibition or other means
- "P" document published prior to the international filing date but later than the priority date claimed

- "T" later document published after the international filing date or priority date and not in conflict with the application but cited to understand the principle or theory underlying the invention
- "X" document of particular relevance; the claimed invention cannot be considered novel or cannot be considered to involve an inventive step when the document is taken alone
- "Y" document of particular relevance; the claimed invention cannot be considered to involve an inventive step when the document is combined with one or more other such documents, such combination being obvious to a person skilled in the art.
- "&" document member of the same patent family

Date of the actual completion of the international search

29 September 2004

Date of mailing of the international search report

20.12.2004

Name and mailing address of the ISA

European Patent Office, P.B. 5818 Patentlaan 2  
NL - 2280 HV Rijswijk  
Tel. (+31-70) 340-2040, Tx. 31 651 epo nl,  
Fax: (+31-70) 340-3016

Authorized officer

Ceccarelli, D

INTERNATIONAL SEARCH REPORT

International application No.  
PCT/US2004/022579

Box II Observations where certain claims were found unsearchable (Continuation of item 2 of first sheet)

This International Search Report has not been established in respect of certain claims under Article 17(2)(a) for the following reasons:

- 1.  Claims Nos.: 57-58  
because they relate to subject matter not required to be searched by this Authority, namely:  
Rule 39.1(iv) PCT - Method for treatment of the human or animal body by surgery
- 2.  Claims Nos.:  
because they relate to parts of the International Application that do not comply with the prescribed requirements to such an extent that no meaningful International Search can be carried out, specifically:
- 3.  Claims Nos.:  
because they are dependent claims and are not drafted in accordance with the second and third sentences of Rule 6.4(a).

Box III Observations where unity of invention is lacking (Continuation of item 3 of first sheet)

This International Searching Authority found multiple inventions in this international application, as follows:

see additional sheet

- 1.  As all required additional search fees were timely paid by the applicant, this International Search Report covers all searchable claims.
- 2.  As all searchable claims could be searched without effort justifying an additional fee, this Authority did not invite payment of any additional fee.
- 3.  As only some of the required additional search fees were timely paid by the applicant, this International Search Report covers only those claims for which fees were paid, specifically claims Nos.:
- 4.  No required additional search fees were timely paid by the applicant. Consequently, this International Search Report is restricted to the invention first mentioned in the claims; it is covered by claims Nos.:  
1-17, 35-56

Remark on Protest

- The additional search fees were accompanied by the applicant's protest.
- No protest accompanied the payment of additional search fees.

FURTHER INFORMATION CONTINUED FROM PCT/ISA/ 210

This International Searching Authority found multiple (groups of) inventions in this international application, as follows:

1. claims: 1-17,35-56

A safety needle assembly with a needle, a body attached to the needle, a base attached to the body, wherein movement of the needle between an insertion position and a protection position creates a positive flush through the distal end of the needle.

---

2. claims: 18-34

A needle device with a needle, a housing with an upper and a lower portion, said upper portion being graspable to facilitate positioning of the needle device, and a collapsible reservoir between the upper and the lower portion.

---

# INTERNATIONAL SEARCH REPORT

Information on patent family members

International Application No

PCT/US2004/022579

Patent document cited in search report	Publication date	Patent family member(s)	Publication date
US 4861341	A	29-08-1989	NONE
WO 0204065	A	17-01-2002	US 6695817 B1 24-02-2004
			AU 8051501 A 21-01-2002
			BR 0112402 A 25-11-2003
			CA 2413728 A1 17-01-2002
			CN 1443082 T 17-09-2003
			CZ 20030023 A3 13-08-2003
			EP 1299148 A2 09-04-2003
			HU 0301556 A2 29-09-2003
			JP 2004516861 T 10-06-2004
			NO 20030103 A 28-02-2003
			NZ 523716 A 30-07-2004
			SI 21083 A 30-06-2003
			WO 0204065 A2 17-01-2002
			US 2004006330 A1 08-01-2004
			US 2004030321 A1 12-02-2004