



(22) Date de dépôt/Filing Date: 2020/07/06

(41) Mise à la disp. pub./Open to Public Insp.: 2021/02/10

(45) Date de délivrance/Issue Date: 2024/01/09

(51) Cl.Int./Int.Cl. *F24T 10/20* (2018.01),
E21B 33/138 (2006.01), *E21B 43/30* (2006.01),
E21B 47/13 (2012.01), *E21B 7/00* (2006.01)

(72) Inventeurs/Inventors:
TOEWS, MATTHEW, CA;
CAIRNS, PAUL, CA;
RIDDELL, DEREK, CA;
CURTIS-SMITH, ANDREW, CA;
HALE, JONATHAN, CA

(73) Propriétaire/Owner:
EAVOR TECHNOLOGIES INC., CA

(74) Agent: SMART & BIGGAR LP

(54) Titre : METHODE DE CONFIGURATION DE PUIXS DE FORAGE DANS UNE FORMATION GEOLOGIQUE

(54) Title: METHOD FOR CONFIGURING WELLBORES IN A GEOLOGIC FORMATION

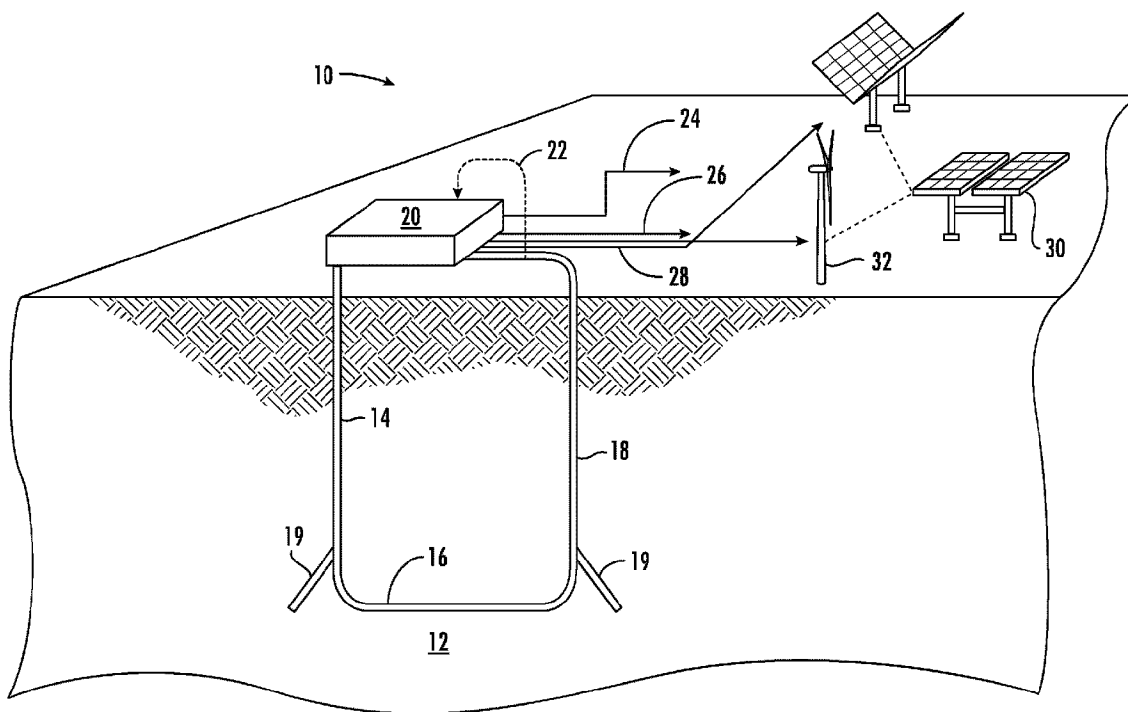

(57) **Abrégé/Abstract:**

Closed loop wellbore configurations with unrestricted geometry for accommodating irregular or challenging thermal gradients within a thermally productive formation are disclosed. A working fluid is utilized in the loop for extraction of thermal energy there from. The loop and the unrestricted geometry are achieved using magnetic ranging of independent drilling operations which intersect from an inlet well and outlet well to form an interconnecting segment. In conjunction with the directional drilling, conditioning operations are incorporated to condition the rock face, cool the entire system, activate the wellbore for treatment to optimize thermal transfer inter alia. The significant degree of freedom in wellbore configuration is further optimized by the absence of mechanical impediments such as casing or liners in the heat transfer areas.

ABSTRACT

Closed loop wellbore configurations with unrestricted geometry for accommodating irregular or challenging thermal gradients within a thermally productive formation are disclosed. A working fluid is utilized in the loop for extraction of thermal energy there from. The loop and the unrestricted geometry are achieved using magnetic ranging of independent drilling operations which intersect from an inlet well and outlet well to form an interconnecting segment. In conjunction with the directional drilling, conditioning operations are incorporated to condition the rock face, cool the entire system, activate the wellbore for treatment to optimize thermal transfer inter alia. The significant degree of freedom in wellbore configuration is further optimized by the absence of mechanical impediments such as casing or liners in the heat transfer areas.

METHOD FOR CONFIGURING WELLBORES IN A GEOLOGIC FORMATION

FIELD OF THE INVENTION

[0001] The present invention relates to configuring wells within a thermally productive geologic formation and more particularly, the present invention relates to optimizing drilling in a formation to facilitate well positioning to maximize recovery of thermal energy from a specific formation thermal gradient.

BACKGROUND OF THE INVENTION

[0002] With the advent of improved drilling techniques for drilling to greater depths in a formation and higher toleration of temperatures, numerous advances have been made to allow for the formation of specific well configurations.

[0003] To elevate the efficiency of well positioning the unification of drilling techniques, working fluid chemistry, wellbore conditioning unit operations together with flow rate, sequencing inter alia must be combined to achieve efficient heat recovery in the most complex and varied thermal gradients in a given formation.

[0004] The present invention facilitates the ability to recover thermal energy regardless of thermal gradient anomalies and complexities.

[0005] In terms of the evolution of the art, one of the earlier developments is realized in Moe, United States Patent No. 6,247,313, issued June 19, 2001. There is disclosure regarding a wellbore configuration which includes a plurality of heat absorbing holes within a geothermal area. The disclosure is silent regarding casing or liners, however it is limited to utilization of a fractured zone, angular disposition of the heat absorbing holes being parallel to each other and further limitations. The teachings specifically state:

“The magnitude of the sloping angle will depend on several factors, for instance the temperature gradient in the rock, the length of the heat absorbing hole and the water flow rate. Calculating the angle will be well within the capabilities of the skilled person and will therefore not be detailed here. The angle would normally lie between 20° and 50°, preferably it will be about 40°.

Furthermore, in order to maximize the extraction of heat from a given volume of rock, at least substantial parts of the heat absorbing holes extend parallel to each other. More

preferably, the heat absorbing holes are arranged in one layer or, if necessary, in a plurality of vertically spaced layers. Providing an array of vertically spaced layers, each layer having a plurality of heat absorbing holes, allows for increasing the capacity of the plant without spreading the holes over a wide area. This is of considerable importance if the volume of earth available for exploitation is not large.

[0006] The supply and return holes are interconnected by four heat absorbing holes ..., each having a diameter of 10 cm and being approximately 2000 m long. The spacing between these holes ... may be 100-150 m. They have been drilled starting out from the supply hole .. and terminate at or near the return hole A fracture zone .. has been established in this area to provide flow communication between the holes ... since it would be difficult to hit the return hole ..directly when drilling the heat absorbing holes

[0007] The teachings also teach a difficulty regarding the connection of the inlet and outlet as emphasized. As a disadvantage, the Moe arrangement would not provide sufficient teaching regarding unrestricted access to a gradient regardless of its anomalies and thus the disclosure is limited to specific scenarios.

[0008] In United States Patent No. 5,515, 679, issued May 14, 1996, Shulman. The document teaches a closed loop thermal energy recovery arrangement in a variety of rock types at higher temperatures, one of which is solid rock which is differentiated in the disclosure of Shulman:

“This invention relates to novel methods and apparatus employing liquid circulation in a closed pipe loop system by which the thermal energy in subterranean hot rock is extracted, i.e. mined, and brought to the surface for utilization. Said hot rock may be solid, fissured or fractured and dry or wet but essentially free of mobile fluid. By this invention, the thermal energy is transferred from the hot rock to relatively cold liquid flowing in one or more of a plurality of distantly separated heat conducting pipe loops that descend from a manifold at the surface into the hot rock and then join together with the bottom of a riser through which the heated fluid returns to the surface.”

[0009] The wellbore configurations are not discussed in any details with complex patterns or disposition of the heat recovering conduits. The arrangement relies on piping in the wellbore configuration for fluid transportation through the arrangement for thermal recovery from the formation. Another disadvantage is seen by the positioning of the manifold on the surface rather than inherently within a downhole network of wellbores.

[0010] Brown, in United States Patent No. 6,668, 554, issued December 30, 2003, teaches a fracturing process for forming a fractured zone in hot dry rock. Super critical

CO2 is used as a working fluid to convey the absorbed energy from the geothermal formation. The fluid communication is not in a closed loop where there is an interconnecting segment in fluid communication between an inlet well and an outlet well where the working fluid is isolated from the formation. In the Brown arrangement, the formation itself indiscriminately communicates with the inlet and outlet wells. This is further evinced by the fact that Brown teaches:

“ Finally, the hot dry rock circulating system is completed by drilling the two or more production wells to intersect the reservoir near each end of the elongated reservoir region as defined by the “cloud” of microseismic event locations defining the shape of the fractured hot dry rock reservoir. All the wells would be appropriately completed with casing to the surface and then purged of drilling fluids and other water-based materials, again using gaseous carbon dioxide.”

[0011] From this passage the use of casing is identified as is an intersection of wells, but not with each other as in a closed loop, but rather with a man-made reservoir within the formation.

[0012] United States Patent No. 10,260,778, Sonju, issued April 16, 2019 discloses a geothermal plant. There are teachings in the patent regarding specific requirements for the production sections of the configuration being in a specific disposition relative to a concentric inlet/outlet well arrangement. The disclosure does not provide instruction regarding conditioning of the wellbores during or after drilling or possible directions for interconnecting segments to exploit the thermally productive zone without restriction.

[0013] Muir et al, in United States Patent No. 10, 527,026, issued January 7, 2020, teach a closed loop heat recovery arrangement for transferring heat from a well casing into the fluid.

The text indicates:

“Embodiments disclosed herein are directed towards methods and apparatus for the production of power from a non-permeable geological resource, through the use of a closed loop design, where the fluid is fully isolated from the formation in a closed loop well and heat is transferred through the well casing into the fluid. ”

“ As described in the background section above, typical hydrothermal systems, as well as closed loop systems, have been focused on extracting heat from permeable geological resources where fractures or porosity occur either naturally or through stimulation. In contrast, embodiments disclosed herein may efficiently and effectively extract heat from low-permeability rock, such as rock in the plastic zone. Geologic formations including higher temperature low-permeable rock are advantageously used by passing a fluid through the resource without direct contact between the fluid and the

rock, whereby heat is transferred directly from the rock through the well casing into the fluid.”

“A closed loop geothermal heat exchange system may then be disposed within the subterranean formation based on the determined temperature profile and the determined heat replenishment profile of the subterranean formation. Emplacement of the closed loop geothermal heat exchange system may include drilling, casing, perforating, cementing, expanding uncased well walls with fractures, sealing uncased well walls and other steps associated with a drilling process and emplacement of a well loop therein as known to one skilled in the art. The emplacing may include, in some embodiments, disposing a heat exchange zone of the closed loop well system within a plastic zone or a brittle-ductile transition zone of the formation. In some embodiments, the emplacing may include or additionally include disposing a heat exchange zone of the closed loop well system within a brittle zone of the formation, as well as stimulating the brittle zone proximate the heat exchange zone.”

[0014] The text provides a general teaching regarding sealing, but includes casing in the heat recovering sections of the wellbore configuration. The text indicates:

“According to some embodiments, methods for producing geothermal energy described herein may include portions of wells that are not cased with metal pipe but, instead, the walls of such portions may be formation rock that has been sealed with hardened sealant and the well wall in such portions being defined by the boundary of such hardened sealant which, in some embodiments, will cause the diameter of the well in such portions to be larger, and in some cases much larger, than in the metal cased portion of such wells.”

[0015] The reference mirrors the teachings of Shulman, supra, and does not provide instruction regarding intersection of wells, the absence of casing and/or liners or geometric variation in the disposition of the heat recovering segments of the wellbore arrangement to accommodate any thermal gradient pattern.

[0016] It would be desirable to have a method of forming a wellbore configuration that can be user adapted to the anomalies of the gradient pattern as opposed to being confined to specific wellbore designs that are adapted to the limitations of the existing equipment and methods for recovering thermal energy.

[0017] The present inventive methods disclosed herein after ameliorate the noted limitations and provide previously unseen degrees of freedom to efficiently capture thermal energy from within a thermally productive formation.

SUMMARY OF THE INVENTION

[0018] One object of one embodiment of the present invention is to provide an improved method for configuring wells and well systems in a thermally productive formation for recovery of thermal energy there from for subsequent use.

[0019] Another object of one embodiment of the present invention is to provide a method for configuring wellbores in a thermally productive geologic formation, comprising: drilling independently in said formation a well having an inlet well and an outlet well; signalling between said inlet well and said outlet well during drilling to intersect to form a continuous well having an interconnecting segment between said inlet well and said outlet well, said interconnecting segment having a predetermined angular configuration relative to said inlet well and said outlet well within said formation; conditioning at least said interconnecting segment to facilitate thermal recovery by working fluid flow therethrough without casing or liner material in said interconnecting segment.

[0019a] Another object of one embodiment of the present invention is a method for configuring wellbores in a thermally productive geologic formation, comprising: drilling independently in said formation a geothermal recovery well having an inlet well and an outlet well; signaling between said inlet well and said outlet well during drilling to intersect to form a continuous well having an interconnecting segment between said inlet well and said outlet well, said interconnecting segment having a predetermined angular configuration relative to said inlet well and said outlet well within said formation, said interconnecting segment comprising a first lateral wellbore extending from a downhole end of said inlet well to a downhole junction and a second lateral wellbore extending from a downhole end of said outlet well to said downhole junction, said second lateral wellbore disposed at a depth greater than a depth of said first lateral wellbore; and conditioning at least said interconnecting segment to facilitate thermal recovery by working fluid flow therethrough, said interconnecting segment being at least partially devoid of casing or liner.

[0019b] Another object of one embodiment of the present invention is a method for configuring wellbores in a geothermally productive geologic formation, comprising: drilling independently in said formation a well having an inlet well and an outlet well; signaling between said inlet well and said outlet well during drilling to intersect to form a continuous well configuration having at least one interconnecting segment in fluid communication with said inlet well and

said outlet well, said interconnecting segment having a predetermined angular configuration relative to said inlet well and said outlet well within said formation, said interconnecting segment comprising a first lateral wellbore extending from a downhole end of said inlet well to a downhole junction and a second lateral wellbore extending from a downhole end of said outlet well to said downhole junction, said second lateral wellbore disposed at a depth greater than a depth of said first lateral wellbore; and conditioning at least said interconnecting segment to facilitate thermal recovery by working fluid flow therethrough, said interconnecting segment being partially cased, lined or devoid of casing or liner.

[0019c] Another object of one embodiment of the present invention is a method for configuring wellbores in a thermally productive geologic formation, the method comprising:

drilling in said formation an inlet well and an outlet well adjacent the inlet well; drilling a first interconnecting well segment and a second interconnecting well segment between said inlet well and said outlet well to form a continuous geothermal recovery well, said interconnecting segments having a predetermined angular configuration relative to said inlet well and said outlet well within said formation, wherein drilling said first interconnecting segment comprises drilling from a downhole end of said inlet well a first lateral wellbore and drilling said second interconnecting segment comprises drilling from a downhole end of said outlet well a second lateral wellbore, the first and second lateral wellbores drilled to extend alongside one another and at least one of the lateral wellbores sloping to intersect a sidewall of the other at a junction, said second lateral wellbore disposed at a depth greater than a depth of said first lateral wellbore; and

conditioning at least said interconnecting segments by sealing the segments to facilitate thermal recovery by working fluid flow therethrough, said interconnecting segments being at least partially open hole

wherein drilling said first interconnecting segment comprises drilling a first group of lateral wellbores from a downhole end of the inlet wellbore and drilling said second interconnecting segment comprises drilling a second group of lateral wellbores from a downhole end of the outlet wellbore, each of the first group of lateral wellbores connected to a respective one of the second group of lateral wellbores at a respective downhole junction, and the conditioning comprises flowing the working fluid from the inlet wellbore to the plurality of downhole junctions and from the plurality of downhole junctions to the outlet wellbore.

[0020] The conditioning is effected by at least one of continuously, discontinuously, during, after and in sequenced combinations of drilling of at least one of drilling the inlet well and the outlet well.

[0021] In greater detail, conditioning may include introducing at least one composition not native to the formation and a unit operation and combinations thereof.

[0022] To augment the effectiveness of the method, one may dynamically modify the conditioning operations responsive to signalling data from at least one of the drilling operations of the inlet and outlet wells.

[0023] Depending on the specific situation the unit operation may include controlling the temperature of drilling fluid, pre-cooling a rock face in the formation being drilled, cooling drilling apparatus and modifying pore space of wellbores formed from drilling in the formation.

[0024] Modification of the pore space may include activating the pore space for subsequent treatment to render it impermeable to formation fluid ingress into the interconnecting segment or egress of the working fluid into the formation, sealing the

pore space during drilling in a continuous operation, sealing pore space during drilling in a discontinuous operation and combinations thereof.

[0025] Operational conditioning modification may also be based on signalling data from signalling between the inlet well and the outlet well.

[0026] Optionally, another unit operation includes forming conduits in the formation relative to a longitudinal axis of an interconnecting segment and in fluid communication therewith for augmenting thermal recovery with the working fluid. The conduits may have a terminal end and positioning of the conduits of an interconnecting segment may be in thermal contact with the adjacent conduits of an adjacent interconnecting segment of another well. The conduits may contain natural buoyancy-driven convection which enhances the effective radius of the heat-collecting interconnecting segment and increases overall heat transfer from the rock volume.

[0027] The conduits may be fractures, single bores, auxiliary segments, or multiple radial bores extending radially from an interconnecting segment.

[0028] When arranged with a vertical component the conduits act as convection cells, where natural buoyancy-driven convection enhances the effective radius of the heat-collecting interconnecting segment. The conduits are typically 0.5 inches (12.7 mm) in diameter or greater, and may be 8.5 inches (215.9 mm) or equal to the diameter of the interconnecting segment itself.

[0029] As another option, conduits of an interconnecting segment may be connected for fluid communication with the adjacent conduits of an adjacent interconnecting segment of another well.

[0030] A further object of one embodiment of the present invention is to provide a well configuration suitable for recovering thermal energy from a thermally productive geologic formation through circulation of fluid there through, comprising:

an inlet well;

an outlet well;

an interconnecting segment in fluid communication with said inlet well and said outlet well and disposed within a thermally productive area of said formation;

a selectively operable auxiliary segment in selective fluid circulation communication with said interconnecting segment for storing heated fluid;

a detritus segment in fluid communication with at least one of said inlet well, said outlet well and said interconnecting segment for collecting well detritus;

said outlet well being at least one of concentric with said inlet well and between 5° and 175° relative to said inlet well, the interconnecting segment being between 5° and 355° relative to said inlet well; and

a conversion device connected with the wells to form a closed loop and collect recovered thermal energy from said fluid for conversion.

[0031] In one embodiment, the auxiliary segment includes a selectively operable valve for allowing stored heated fluid circulation access to the interconnecting segment and may further include a selectively operable outlet in fluid communication with at least one of the conversion device and an adjacent well configuration.

[0032] The configurations may be a plurality of well configurations in a concentric and spaced relation, a plurality of well configurations in a spaced laterally offset parallel planar relation and may further include at least one of a common inlet well and a common outlet well.

[0033] For the thermal energy collection, the interconnecting segments are utilized and the configurations can provide a plurality of interconnecting segments in fluid communication with the inlet well and the outlet well with a plurality of spaced apart arrays of interconnecting segments in a predetermined pattern.

[0034] A still further object of one embodiment of the present invention is to provide a method of forming a well configuration suitable for recovering thermal energy from a thermally productive geologic formation through circulation of fluid there through, comprising:

independently drilling an inlet well and an outlet well in a predetermined location in the formation;

intersecting drilling from the inlet well and the outlet well to form an interconnecting segment between the inlet well and the outlet well in a predetermined thermally productive area of the formation position in the formation, the outlet well being at least one of concentric with said inlet well and between 5° and 175° relative to said inlet well, said interconnecting segment being between 5° and 355° relative to said inlet well;

forming a selectively operable auxiliary segment in selective fluid circulation communication with said interconnecting segment for storing heated fluid;

forming a detritus segment in fluid communication with at least one of said inlet well, said outlet well and said interconnecting segment for collecting well detritus; and

providing a conversion device connected with the wells to form a closed loop and collect recovered thermal energy from said fluid for conversion.

[0035] For the intersection drilling, drilling independently from the inlet well and the outlet well to form an interconnecting segment between the inlet well and the outlet is conducted by electromagnetic signalling.

[0036] Electromagnetic signalling devices will be utilized for the signalling and will be selectively positioned in predetermined location combinations of the inlet well, the outlet well, the detritus segment and the interconnecting segment.

[0037] The devices may be operated in a predetermined sequence.

[0038] Further, the method includes signalling a well in progress with signalling from a previously formed adjacent well.

[0039] The method is well suited to recovery of thermal energy from a geothermal formation having a temperature of not less than 40°C.

[0040] For efficiency and flexibility of deployment in a formation, circulation of fluid within the interconnecting segment may be performed in the absence of casing and liners.

[0041] A plurality of interconnecting segments in embodiments can be in fluid communication with the inlet well and the outlet well, with the configuration having a plurality of spaced apart arrays of interconnecting segments in a predetermined pattern.

[0042] Optionally there may be a step of selectively circulating the fluid from one array as a slipstream to an inlet point of a spaced second array prior to discharge at the outlet well common to all arrays. In this way, the slipstream preheats fluid from the inlet well prior to circulation in the spaced second array.

[0043] The slipstream may also be distributed to an adjacent well configuration for thermal augmentation of the adjacent well.

[0043a] According to another embodiment, the disclosure relates to a well configuration suitable for recovering thermal energy from a thermally productive geologic formation through circulation of fluid there through, comprising: an inlet well; an outlet well; an interconnecting segment in fluid communication with said inlet well and said outlet well and disposed within a thermally productive area of said formation; a selectively operable auxiliary segment in fluid circulation communication with said interconnecting segment for storing heated fluid; a detritus segment in fluid communication with at least one of said inlet well, said outlet well and said interconnecting segment for collecting well detritus; said outlet well being at least one of concentric with said inlet well and between 5° and 175° relative to said inlet well; the interconnecting segment being between 5° and 355° relative to said inlet well; and a conversion device connected with the wells to form a closed loop and collect recovered thermal energy from said fluid for conversion.

[0043b] According to another embodiment, the disclosure relates to a method of forming a well configuration suitable for recovering thermal energy from a thermally productive geologic formation through circulation of fluid there through, comprising: independently drilling an inlet well and an outlet well in a predetermined location in said formation; intersecting drilling from said inlet well and said outlet well to form an interconnecting segment between said inlet well and said outlet well in a predetermined thermally productive area of said formation position in said formation, said outlet well being at least one of concentric with said inlet well and between 5° and 175° relative to said inlet well, said interconnecting segment being between 5° and 355° relative to said inlet well; forming a selectively operable auxiliary segment in selective fluid circulation communication with said interconnecting segment for storing heated fluid; forming a detritus segment in fluid communication with at least one of said inlet well, said outlet well and

said interconnecting segment for collecting well detritus; and providing a conversion device connected with the wells to form a closed loop and collect recovered thermal energy from said fluid for conversion.

[0043c] According to another embodiment, the disclosure relates to a closed-loop geothermal well for geothermal heat recovery from a subterranean geothermal zone, comprising: an inlet wellbore extending from the terranean surface to the geothermal zone; an outlet wellbore extending from the terranean surface to the geothermal zone; a first open hole lateral wellbore extending out from the inlet wellbore into the geothermal zone; and a second open hole lateral wellbore extending out from the outlet wellbore into the geothermal zone at a different depth than the first lateral wellbore, the first and second lateral wellbores coupled at their ends, opposite the inlet and outlet wellbores, to allow fluid to circulate from the inlet wellbore to the first lateral wellbore, from the first lateral wellbore to the second lateral wellbore and from the second lateral wellbore to the outlet wellbore.

[0043d] According to another embodiment, the disclosure relates to a method for forming a closed-loop geothermal well in a subterranean geothermal zone, comprising: drilling a first open hole lateral wellbore from an inlet wellbore into the geothermal zone, the inlet wellbore extending from the terranean surface; and drilling, at a different depth than the first lateral wellbore, a second open hole lateral wellbore from an outlet wellbore into the geothermal zone to the first lateral wellbore to allow fluid to circulate from the inlet wellbore to the first lateral wellbore, from the first lateral wellbore to the second lateral wellbore, and from the second lateral wellbore to the outlet wellbore, the outlet wellbore extending from the terranean surface.

[0044] Having thus generally described the invention, reference will now be made to the accompanying drawings, illustrating preferred embodiments.

BRIEF DESCRIPTION OF THE DRAWINGS

[0044] Figure 1 is a schematic illustration of a closed loop energy recovery arrangement;

[0045] Figure 2 is a coordinate system illustrating the possible positions of an interconnecting segment or segment group within the volume of a formation to have thermal energy recovered therefrom;

[0046] Figure 3 is a flow chart delineating the steps involved in forming a wellbore configuration by drilling intersection of at least two points;

[0047] Figure 4 is a cross section of a wellbore variation;

[0048] Figure 5 is side view of Figure 4;

[0049] Figure 6 is an alternate embodiment of Figure 5;

[0050] Figure 7 is an embodiment of a wellbore configuration;

[0051] Figure 8 is an alternate embodiment of a wellbore configuration;

[0052] Figure 9 is a further alternate embodiment of a wellbore configuration;

[0053] Figure 10 is a further alternate embodiment of a wellbore configuration;

[0054] Figure 11 is a further alternate embodiment of a wellbore configuration;

[0055] Figure 12 is a further alternate embodiment of a wellbore configuration;

[0056] Figure 13 is a schematic illustration of a system of wellbore configurations within a formation;

[0057] Figure 14 is a schematic illustration of a network of sectored wellbore configurations;

[0058] Figure 15 is schematic illustration of a wells system illustrating the detritus segments;

[0059] Figure 16 is a schematic illustration of stacked wells in a modular format;

[0060] Figure 16A is an alternate embodiment of Figure 16;

[0061] Figure 17 is a schematic illustration of a well system where there is interconnection between auxiliary segments; and

[0062] Figure 18 is a schematic illustration of a network of well systems integrated with an electrical grid

[0063] Similar numerals used in the Figures denote similar elements.

DETAILED DESCRIPTION OF THE PREFERRED EMBODIMENTS

[0064] Referring to Figure 1, shown is a schematic representation of a closed loop well system 10 disposed within a thermally productive formation 12. The system 10 includes an inlet well 14, an interconnecting well segment 16 and an outlet well 18 in closed loop fluid communication with an energy processing device 20 positioned on the surface, S. The outlet well may be co-located with the inlet well at the device 20 or located distally as shown by the dashed line 22 for alternate connection. A working fluid is circulated through the system 10 in order to absorb thermal energy from within the formation 12.

[0065] For efficiency, the interconnecting well segment 16 is not cased or lined and does not include any other pipe or related mechanical arrangements. The outlet well 18 and inlet well 16 may be cased or otherwise made to comply with accepted practices known to those skilled in the art. Any detritus that evolves from use of the arrangement may be collected in segments 19.

[0066] Energy processing device 20 may process the energy for other uses broadly denoted by numeral 24, stored at 26 or passed on to an electrical grid 28 which optionally may include solar devices 30 and/or wind devices 32 in any suitable combination.

[0067] In respect of the spatial orientation of the wells within a thermally productive formation, reference may be had to Figure 2. In the illustration, elements have been removed for clarity, however it will be understood that the illustration is to convey the disposition of the interconnecting segment 16 may have relative to at least one of the plane of the inlet well 14 and outlet well 18.

[0068] In the Figure, the interconnecting well segment 16 may be positioned at any angle within any of the planes (X-Y), (X- (-Y)) ((-X)- Y) ((-X) – (-Y)), (X-Z), (X- (-Z)), (Z- (-X)), ((-X)- (-Z)), (Z-Y), (Z- (-Y)), ((-Z)-(-Y)) and ((-Z)-Y) and may also be disposed to have an X,Y and Z coordinate for cross plane disposition. For purposes of explanation the positive x axis will represent the inlet well 14. The well may be disposed at any angle alpha or beta in a range which does not impede operation of the well 14. This is equally true for outlet well 18. The inlet wells 14 and outlet wells 18 communicate with the surface ,S, as referenced in respect of Figure 1.

[0069] Any number of interconnecting segments 16 may be disposed within the space discussed. Other well configurations will be discussed in the advancing Figures. The quantity and spatial positioning will depend on the thermal gradient of the formation 12.

[0070] Advantageously, the observation of the drilling by intersection between the inlet well 14 and outlet well 16 by independent drilling operations to form the interconnecting segment 18, the absence of liners, casing, etc. within the interconnecting segment with conditioning of the drilling operation, results in configuration freedom to maximally recover thermal energy.

[0071] Figure 3 illustrates an example of the steps involved in sensor ranging the inlet well and outlet well in a formation for intersection through the formed interconnecting segment. Although the example references an interconnecting segment, it will be understood that the methodology relates to multiple interconnecting segments formation in any pattern as discussed in respect of Figure 2. The individual interconnecting segments are fully utilizable to have sensor communication there between to guide the drilling of subsequent interconnecting segments with a given well system or those being formed in a proximate system within the formation. By providing the cross

communication between the wells, the inlets, the outlets and interconnecting segments, trajectory drift is minimized to facilitate accurate intersection of the wells being drilled. Sensors may also be utilized in the detritus capture segments 19 , not shown and discussed in greater detail herein after.

[0072] Referring now to Figure 4, a cross section of an interconnecting segment 16 is shown disposed with formation 12. Extending from the segment 16 are or conduits 34 extending into the formation 12. Conduits 34 may be voids either in fluid communication with the interior 36 of segment 16 or sealed without fluid communication with the interior 36. It has been found that the conduits 34 are useful to enhance the thermal recovery capacity of the interconnecting segment when working fluid is circulated there though as well in periods of quiescence. Positioning and quantity of the radially extensions will be dictated by formation characteristics to maximize thermal recovery without structural/mechanical compromise of the segment 16. Where adequate, if pre-existing fissures, cracks, fractures or contained areas of permeability are encountered, they may be used to function as conduits. These may also occur during drilling of the segment 16.

[0073] Figure 5 illustrates an example where the conduits 34 are arranged in a generally helical pattern with the dotted points representing those extending outwardly from the plane and those crossed points being representative of the extensions on the opposed surface extending away from the plane. This is exemplary; the pattern will be ascertained from gradient data amongst other germane parameters.

[0074] Figure 6 illustrates a further example where a plurality of segments 16 are disposed within formation 12. In the example, the extensions 34 of adjacent segments may be arranged in close proximity to fill a given area 38 with extensions to effectively increase the volume of the gradient from which thermal energy may be recovered. The conduits 34 act as a convection cell of buoyancy driven flow which direct thermal energy into the interior 34 of segments 16. The extensions can be arranged for adjacent positioning or interdigitated with other conduits 34.

[0075] As a further embodiment, the individual segments 16 may be connected by the conduits 34, the connection being generally denoted by numeral 40. In this manner, the arrangement has the appearance of a ladder when viewed perspective.

[0076] Turning now to the well configuration possibilities, Figure 7 illustrates a generally toroidal well configuration generally denoted by numeral 42 disposed within formation 12.

[0077] In this arrangement, inlet well 14 is in fluid communication with a main inlet hub well 44 which is connected to each of the interconnecting segments 16. Suitable valve

devices (not shown, but generally represented by numeral 46) may be incorporate in some or all of the looped segments 16 for fluid flow redirection and other control. The arrangement 42 also includes a main outlet hub well 48 connected in a similar manner as that indicated for main inlet hub well 46 with a similar valving feature (not shown).

[0078] Within the structure, each looped segment 16 may be operated as a single unit to recover thermal energy.

[0079] As an operational alternative, the flow of working fluid within arrangement 42 may be circulated in a generally helical pattern through the whole arrangement with sequencing of periods of quiescence to allow for maximum thermal recovery. Such flexibility allows for connection to, for example the energy processing device 20. This facilitates on demand power when the energy is converted to electricity and overcomes the limitations associated with baseload power peak delivery issues.

[0080] Figure 8 illustrates a further embodiment of a well configuration denoted by numeral 50. The general shape is that of a saddle where the interconnecting looped segments are adjacent one another with an arcuate presentation. The inlet well 14 may be connected to each of the looped segments 16 in a hub or manifold arrangement 52 or valved at 54 for selective operation. In a similar manner, outlet 18 may connected in the same fashion.

[0081] Figure 9 illustrates yet another possible variation generally in the form of an inverted parabola.

[0082] Figure 10 illustrates another well system configuration where the inlets 14 may be singular from distant points in the configuration or joined at 56. Similarly, outlets 18 may be combined at 58. For colocation, the outlets 58 and inlets 56 may be extended for geographic proximity.

[0083] Figure 11 illustrates a general cone shaped configuration where the outlet well 18 may be at the bottom portion of the configuration or the top as shown in dashed line. The lower parts of the looped segments 16 may be connected together or independent.

[0084] Figure 12 illustrates yet another configuration in the general form of a whisk. In this embodiment, the segment loops 16 may have a concentric inlet 14 and outlet 18 with fluid flow from the inlet in the direction of arrow 62 and outlet flow at 64. This arrangement allows for a large volume of the formation to be " mined" for heat in the formation 12 outside of the configuration and in the formation volume 66 within the configuration. One of the advantages with this configuration are that all of the intersections happen with a single borehole or "mother bore" and electromagnetic

signalling can be simplified, even accomplished with permanent devices placed in the mother bore or passively. Another advantage is only a single vertical bore is required to house both the inlet and outlet flow streams.

[0085] Turning to Figure 13, a wellbore system sector is schematically depicted generally denoted by numeral 68. Sector 68 is within a thermally productive formation 12, with the positioning of different wellbore configurations positioned in predetermined zones to maximize gradient coverage. In the example, the sector 68 provides a stacked and spaced arrangement of looped segments 16 sharing a common inlet well 14 and common outlet well 18.

[0086] Depending on the parameters, fluid circulation may follow the pattern denoted A through F. In this manner, at least a portion of heated fluid from top looped segments 70 may preheat the fluid entering bottom looped segments 72. Alternatively, each of the looped segments 70 and 72 can be operated independently.

[0087] In respect of the remaining configurations, the toroidal configuration 80 may receive heated fluid from the outlet 18 of the stacked arrangement 70, 72 as denoted by the dashed lines 74 or simply have an independent inlet well 14 denoted by the chain line 76.

[0088] The whisk configuration may have an independent inlet well 14 and a bottom positioned outlet well 18 or the inlet well may be common with that of the toroidal configuration as denoted by numeral 78.

[0089] Finally, the saddle configuration may include a common outlet well with the toroidal configuration at 80.

[0090] It will be understood that all inlet wells 14 and outlet wells 18 will extend to the surface or conversion device 20 (Figure 1) for operation. In the Figure 13, the wells 14, 18 are truncated for purposes of clarity in the illustration.

[0091] The sector 68 is exemplary only as are the wellbore configurations and common and independent combinations. With the intersecting directional drilling, the conditioning operations and sensor guided drilling, any pattern or configuration can be synthesized to exploit even the most irregular, disparate multizonal gradient distributions. All of these features when unified with the fact that the instant technology does not include piping liners or other mechanical arrangements within the heat recovering interconnecting

segments, immediately removes geometric constraints for the configurations thus allowing the mining of any gradient in any rock formation.

[0092] Figure 14 is another example of a well arrangement 82 to recover thermal energy from a specific volume of the formation 12. In the example, the detritus segments 19 may include sensors 84 to transmit information regarding detritus accretion. In this manner, the working fluid may be compositionally altered to incorporate chemical additives to mitigate/repair any compromised areas with the well system. The arrangement of the interconnecting segments 16 may be disposed in a spaced array as shown to recover thermal energy.

[0093] Further, as illustrated in Figure 15 auxiliary segments 86 may be in fluid communication with a respective segment 16 to which it is attached and incorporate a valve mechanism 88 to allow for selective operation. The auxiliary segments 88 may be used to store heated working fluid selectively used as a thermal driver in the arrangement for the well system in the example or used via suitable interconnection to another well system (not shown in this Figure). As illustrated, the auxiliary segments 86 may be positioned in a coplanar disposition with the segment to which it is attached or in an orthogonal plane as shown in dashed lines in the Figure. Suitable variations to this are envisioned depending on the gradient features.

[0094] Figures 16 and 16 A illustrate grouped well systems 82 in different angular dispositions within the formation. In the grouped configurations, the systems 82 are modularized within a specific volume of the formation 12 thus allowing for a small footprint and convenient general co-location of the inlet well 14 and outlet well 18. Within the module, inlet wells 14 and outlet wells may be common to individual well systems or common for all modules in the system 82.

[0095] Figure 17 provides for the possibility of interconnecting auxiliary segments 86 between adjacent wells at 90 or thermal supplementation from one outlet 18 to an inlet 14 of an adjacent well.

[0096] In Figure 18 a network is depicted and intended to convey the feature that the energy produced within any well system 82 can be taken directly for other uses through the energy producing apparatus 20 associated with that system 82, combined from one system 82 to another 82 as denoted by numeral 96 or further grouped as denoted by numeral 98 for eventual use on the electrical grid 28 to provide on demand power regardless of quantitative demand.

WE CLAIM:

1. A method for configuring wellbores in a thermally productive geologic formation, the method comprising:

drilling in said formation an inlet well and an outlet well adjacent the inlet well;

drilling a first interconnecting well segment and a second interconnecting well segment between said inlet well and said outlet well to form a continuous geothermal recovery well, said interconnecting segments having a predetermined angular configuration relative to said inlet well and said outlet well within said formation, wherein drilling said first interconnecting segment comprises drilling from a downhole end of said inlet well a first lateral wellbore and drilling said second interconnecting segment comprises drilling from a downhole end of said outlet well a second lateral wellbore, the first and second lateral wellbores drilled to extend alongside one another and at least one of the lateral wellbores sloping to intersect a sidewall of the other at a junction, said second lateral wellbore disposed at a depth greater than a depth of said first lateral wellbore; and

conditioning at least said interconnecting segments by sealing the segments to facilitate thermal recovery by working fluid flow therethrough, said interconnecting segments being at least partially open hole

wherein drilling said first interconnecting segment comprises drilling a first group of lateral wellbores from a downhole end of the inlet wellbore and drilling said second interconnecting segment comprises drilling a second group of lateral wellbores from a downhole end of the outlet wellbore, each of the first group of lateral wellbores connected to a respective one of the second group of lateral wellbores at a respective downhole junction, and the conditioning comprises flowing the working fluid from the inlet wellbore to the plurality of downhole junctions and from the plurality of downhole junctions to the outlet wellbore.

2. The method as set forth in claim 1, wherein conditioning is effected by at least one of continuously, discontinuously, during, after and in sequenced combinations of drilling of at least one of drilling said inlet well and said outlet well.
3. The method as set forth in claim 1 or claim 2, wherein the conditioning includes introducing at least one of a composition not native to said formation or performing a unit operation.
4. The method as set forth in any one of claims 1 to 3, further including the step of dynamically modifying said conditioning responsive to signaling data obtained during drilling of said inlet well and said outlet well.
5. The method as set forth in claim 1, wherein the conditioning comprises performing a unit operation, said unit operation includes controlling the temperature of drilling fluid; pre-cooling a rock face in said formation being drilled; and sealing pore space in said formation.
6. The method as set forth in any one of claims 1 to 5, wherein said conditioning includes sealing said interconnecting segment with said composition not native to said formation.
7. The method as set forth in claim 6, wherein said sealing forms a sealed wellbore in said formation for facilitating thermal recovery by circulation of a working fluid flow therethrough.
8. The method as set forth in claim 5, wherein sealing the pore space comprises

at least one of i) rendering said pore space impermeable to formation fluid ingress into at least a portion of said interconnecting segments or egress of said working fluid into said formation, ii) sealing said pore space during drilling in a continuous operation, or iii) sealing said pore space during drilling in a discontinuous operation

9. The method as set forth in claim 5, further including the step of selecting a modification based on signaling data from signaling between said inlet well and said outlet well.

10. The method as set forth in claim 3, wherein said unit operation includes forming conduits in said formation relative to a longitudinal axis of said interconnecting segments and in fluid communication therewith for augmenting thermal recovery with said working fluid.

11. The method as set forth in claim 10, wherein said conduits have a terminal end.

12. The method of claim 10 or claim 11, wherein said conduits comprise at least one of radial bore segments, induced fractures, induced cracks, or induced fissures

13. The method as set forth in claim 11 or claim 12, further including the step of augmenting thermal recovery with said conduits by flowing a portion of the working fluid into the conduits and allowing the portion of the working fluid in the conduits to heat a portion of the working fluid inside the interconnecting segments.

14. The method as set forth in claim 12 or claim 13, further including the step of positioning radial bore segments of the second interconnecting segment in thermal contact with an adjacent radial bore segment of an adjacent interconnecting

segment of another well.

15. The method as set forth in any one of claims 12 to 14, further including the step of connecting radial bore segments of the second interconnecting segment for fluid communication with the adjacent radial bore segment of an adjacent interconnecting segment of another well.

16. The method as set forth in any one of claims 1 to 15, further including positioning said interconnecting segment relative to a plane of said inlet well and a plane of said outlet well within said formation where the plane of said interconnecting segment is in a plane that is selected from the group comprising: an orthogonal plane, an acute plane, an obtuse plane, coplanar and a parallel plane relative the plane of at least one of the inlet well and outlet well.

17. The method as set forth in any one of claims 1 to 16, further including the step of forming a plurality of interconnecting segments in a predetermined pattern in fluid communication with said inlet well and said outlet well.

18. The method as set forth in claim 17, wherein said predetermined pattern includes patterns where at least one of said plurality of interconnecting segments are in a predetermined angular relationship relative to one another, said plurality of interconnecting segments are in a predetermined angular relationship relative to said inlet well, said plurality of interconnecting segments are in a predetermined angular relationship relative to said outlet well and combinations thereof.

19. The method as set forth in claim 17 or claim 18, further including the step of forming at least one predetermined second pattern of interconnecting segments.

20. The method as set forth in claim 19, further including the step of forming a plurality of said predetermined second patterns in at least one of a predetermined angular relationship relative to one another, predetermined angular relationship relative to said predetermined pattern of interconnecting segments and combinations thereof.

21. The method as set forth in any one of claims 17 to 20, further including at least one of:

commonly connecting an inlet well, an outlet well and combinations thereof of wells of said predetermined pattern and said second predetermined pattern;

utilizing a pre-existing or a newly formed inlet well and newly formed outlet well for connecting wells of said predetermined pattern and said second predetermined pattern; and

combinations thereof.

22. The method as set forth in claim 21, further including the step of co-locating at least one of all inlet wells, selected inlet wells, all outlet wells, selected outlet wells and combinations thereof.

23. The method as set forth in any one of claims 19 to 22, further including the step of co-locating at least one of all inlet wells and all outlet wells of second predetermined patterns.

24. The method as set forth in any one of claims 19 to 23, further including the step of selectively circulating fluid from at least one predetermined second pattern of predetermined second patterns as a slipstream to an inlet well of another second pattern of said patterns prior to discharge at an outlet well of said another second pattern.

25. The method as set forth in any one of claims 1 to 24, further including the step of forming a selectively operable auxiliary segment in fluid circulation communication with said interconnecting segment for storing heated fluid.

26. The method as set forth in claims 1 to 25, further including the step of forming a detritus segment in fluid communication with at least one of said inlet well, said outlet well and said interconnecting segment for collecting well detritus.

27. The method as set forth in any one of claims 1 to 26, wherein said outlet well is at least one of concentric with said inlet well and between 5° and 175° relative to said inlet well.

28. The method as set forth in any one of claims 1 to 27, wherein said interconnecting segment is between 5° and 355° relative to said inlet well.

29. The method as set forth in any one of claims 26 to 28, further including selectively positioning electromagnetic signaling devices in predetermined combinations of said inlet well, said outlet well, said detritus segment and said interconnecting segment.

30. The method as set forth in claim 29, further including the step of operating said electromagnetic signaling devices in a predetermined sequence.

31. The method as set forth in claim 29 or claim 30, further including the step of signaling a well in progress with signaling from a previously formed adjacent well.

32. The method as set forth in claim 1, wherein the downhole end of the inlet

wellbore comprises a first juncture from which the first lateral wellbore extends, and the downhole end of the outlet wellbore comprises a second juncture from which the second lateral wellbore extends, and at least the first juncture and second juncture are open hole.

33. The method as set forth in claim 1, comprising drilling the first group of lateral wellbores and second group of lateral wellbores to slope downward continuously from the downhole end of the inlet wellbore and the downhole end of the outlet wellbore, respectively, to respective downhole junctions residing deeper than a depth of both the downhole end of the inlet wellbore and the downhole end of the outlet wellbore.

34. The method as set forth in claim 1, wherein drilling the first lateral wellbore comprises drilling a deviated section at the downhole end of the first lateral wellbore, the deviated section deviating from the trajectory of the rest of the first lateral wellbore and extending to the downhole junction.

35. The method of claim 1, wherein the first and second lateral wellbores intersect at a V-shaped junction.

36. The method of claim 1, comprising drilling a detritus segment extending downward from the intersection.

37. The method of claim 1, wherein drilling the inlet well comprises drilling a new vertical wellbore for geothermal heat recovery and drilling the outlet well comprises drilling a new vertical wellbore for geothermal heat recovery.

38. A well configuration suitable for recovering thermal energy from a thermally productive geologic formation through circulation of fluid there through, comprising:
- an inlet well;
 - an outlet well;
 - an interconnecting segment in fluid communication with said inlet well and said outlet well and disposed within a thermally productive area of said formation;
 - a selectively operable auxiliary segment in fluid circulation communication with said interconnecting segment for storing heated fluid;
 - a detritus segment in fluid communication with at least one of said inlet well, said outlet well and said interconnecting segment for collecting well detritus;
 - said outlet well being at least one of concentric with said inlet well and between 5° and 175° relative to said inlet well;
 - the interconnecting segment being between 5° and 355° relative to said inlet well; and
 - a conversion device connected with the wells to form a closed loop and collect recovered thermal energy from said fluid for conversion.
39. The well configuration as set forth in claim 38, wherein said auxiliary segment includes a selectively operable valve for allowing stored heated fluid circulation access to said interconnecting segment.
40. The well configuration as set forth in claim 38 or 39, wherein said auxiliary segment includes a selectively operable outlet in fluid communication with at least one of said conversion device and an adjacent well configuration.

41. The well configuration as set forth in any one of claims 38 through 40, wherein said auxiliary segment augments thermal recovery by containing buoyancy driven convection cells.
42. The well configuration as set forth in any one of claims 38 through 41, wherein said configuration comprises a plurality of said well configurations.
43. The well configuration as set forth in claim 42, wherein said configuration comprises a plurality of said well configurations in at least one of a concentric and spaced relation, a spaced laterally offset parallel planar relation, including a common inlet well and a common outlet well and combinations thereof.
44. The well configuration as set forth in claim 15, wherein said configuration includes a plurality of interconnecting segments in fluid communication with said inlet well and said outlet well, said configuration having a plurality of spaced apart arrays of said interconnecting segments in a predetermined pattern.
45. The well configuration as set forth in claim 44, wherein said plurality of interconnecting segments include at least one of a common inlet well and a common outlet well.
46. The well configuration as set forth in claim 44, wherein said plurality of interconnecting segments each have an inlet well and are collectively connected to a common outlet well.

47. The well configuration as set forth in claim 38, wherein said detritus segment includes a sensor for sensing collected detritus in said segment.
48. A method of forming a well configuration suitable for recovering thermal energy from a thermally productive geologic formation through circulation of fluid there through, comprising:
- independently drilling an inlet well and an outlet well in a predetermined location in said formation;
 - intersecting drilling from said inlet well and said outlet well to form an interconnecting segment between said inlet well and said outlet well in a predetermined thermally productive area of said formation position in said formation, said outlet well being at least one of concentric with said inlet well and between 5° and 175° relative to said inlet well, said interconnecting segment being between 5° and 355° relative to said inlet well;
 - forming a selectively operable auxiliary segment in selective fluid circulation communication with said interconnecting segment for storing heated fluid;
 - forming a detritus segment in fluid communication with at least one of said inlet well, said outlet well and said interconnecting segment for collecting well detritus; and
 - providing a conversion device connected with the wells to form a closed loop and collect recovered thermal energy from said fluid for conversion.
49. The method as set forth in claim 48, wherein intersecting drilling from said inlet well and said outlet well to form an interconnecting segment between said inlet well and said outlet is conducted by electromagnetic signaling.

50. The method as set forth in claim 49, further including selectively positioning electromagnetic signaling devices in predetermined combinations of said inlet well, said outlet well, said detritus segment and said interconnecting segment.
51. The method as set forth in claim 50, further including the step of operating said electromagnetic signaling devices in a predetermined sequence.
52. The method as set forth in claim 51, further including the step of signaling a well in progress with signalling from a previously formed adjacent well.
53. The method as set forth in claim 48, further including the step of positioning a sensor in said detritus segment.
54. The method as set forth in claim 53, further including the step of altering the chemical composition of said working fluid in response to a sensed signal from said detritus segment.
55. The method as set forth in any one of claims 48 through 54, wherein said formation is a geothermal formation.
56. The method as set forth in any one of claims 48 through 55, further including the step of circulating fluid within said interconnecting segment in the absence of casing and liners.
57. A closed-loop geothermal well for geothermal heat recovery from a subterranean geothermal zone, comprising:

- an inlet wellbore extending from the terranean surface to the geothermal zone;
 - an outlet wellbore extending from the terranean surface to the geothermal zone;
 - a first open hole lateral wellbore extending out from the inlet wellbore into the geothermal zone; and
 - a second open hole lateral wellbore extending out from the outlet wellbore into the geothermal zone at a different depth than the first lateral wellbore, the first and second lateral wellbores coupled at their ends, opposite the inlet and outlet wellbores, to allow fluid to circulate from the inlet wellbore to the first lateral wellbore, from the first lateral wellbore to the second lateral wellbore and from the second lateral wellbore to the outlet wellbore.
58. The closed-loop geothermal well of claim 57, where the first and second lateral wellbores are each sloping.
59. The closed-loop geothermal well of claim 57, where the inlet wellbore and the outlet wellbore are co-located at the terranean surface.
60. The closed-loop geothermal well of claim 57, comprising:
- casing in the inlet wellbore; and
 - casing in the outlet wellbore.
61. The closed-loop geothermal well of claim 60, where the rock around the first and the second lateral wellbores is sealed.

62. The closed-loop geothermal well of claim 57, comprising a plurality of first open hole lateral wellbores extending out from the inlet wellbore into the geothermal zone and a plurality of second open hole lateral wellbores extending out from the outlet wellbore into the geothermal zone, and where respective pairs of first and second lateral wellbores are coupled at their ends opposite the inlet and outlet wellbores.
63. The closed-loop geothermal well of claim 62, where the inlet wellbore and the outlet wellbore are co-located at the terranean surface.
64. The closed-loop geothermal well of claim 62, where the plurality of first and second lateral wellbores are sloping.
65. The closed-loop geothermal well of claim 62, where a respective pair of the laterals intersect at their ends opposite the inlet wellbore and the outlet wellbore.
66. The closed-loop geothermal well of claim 65, where each respective pair of laterals define a detritus capture segment at their intersection.
67. The closed-loop geothermal well of claim 57, where the first lateral wellbore and the second lateral wellbore intersect at their ends opposite the inlet wellbore and the outlet wellbore.

68. The closed-loop geothermal well of claim 57, comprising a sloped wellbore segment where the first and second lateral wellbores couple, the sloped wellbore segment inclined more steeply than the remainder of the wellbore having the sloped wellbore segment.
69. The closed-loop geothermal well of claim 57, where the inlet wellbore and the outlet wellbore reside at a surface site; and comprising:
- a second inlet wellbore extending from the terranean surface to the geothermal zone and residing at the surface site;
 - a second outlet wellbore extending from the terranean surface to the geothermal zone and residing at the surface site;
 - a third open hole lateral wellbore extending out from the second inlet wellbore into the geothermal zone; and
 - a fourth open hole lateral wellbore extending out from the second outlet wellbore into the geothermal zone at a different depth than the third lateral wellbore, the third and fourth lateral wellbores coupled at their ends, opposite the second inlet and second outlet wellbores, to allow fluid to circulate from the second inlet wellbore to the third lateral wellbore, from the third lateral wellbore to the fourth lateral wellbore and from the fourth lateral wellbore to the second outlet wellbore.
70. A method for forming a closed-loop geothermal well in a subterranean geothermal zone, comprising:
- drilling a first open hole lateral wellbore from an inlet wellbore into the geothermal zone, the inlet wellbore extending from the terranean surface; and

- drilling, at a different depth than the first lateral wellbore, a second open hole lateral wellbore from an outlet wellbore into the geothermal zone to the first lateral wellbore to allow fluid to circulate from the inlet wellbore to the first lateral wellbore, from the first lateral wellbore to the second lateral wellbore, and from the second lateral wellbore to the outlet wellbore, the outlet wellbore extending from the terranean surface.

71. The method of claim 70, comprising:

- drilling and casing the inlet wellbore;
- drilling and casing the outlet wellbore; and
- leaving the first lateral wellbore and the second lateral wellbore open hole.

72. The method of claim 71, comprising sealing the rock surrounding first lateral wellbore and the second lateral wellbore.

73. The method of claim 72, comprising circulating a heat transfer working fluid in the wellbores while maintaining the first lateral wellbore and the second lateral wellbore sealed.

74. The method of claim 72, comprising:

- drilling a plurality of first open hole lateral wellbores from the inlet wellbore into the geothermal zone; and

- drilling a plurality of second open hole lateral wellbores from the outlet wellbore into the geothermal zone to each couple to a respective one of the first open hole lateral wellbores.
75. The method of claim 73, comprising:
- a. sealing the plurality of first and second wellbores; and
 - b. circulating a heat transfer working fluid while maintaining the first and second wellbores sealed.
76. The method of claim 70, where drilling the first open hole lateral wellbore and drilling the second open hole lateral wellbore comprise drilling the lateral wellbores to intersect.
77. The method of claim 70, comprising drilling a sloped wellbore segment where the first and second lateral wellbores couple, the sloped wellbore segment inclined more steeply than the remainder of the wellbore having the sloped wellbore segment.
78. The method of claim 70, comprising:
- drilling the inlet wellbore at a surface site;
 - drilling the outlet wellbore at the surface site;
 - drilling a second inlet wellbore at the surface site;
 - drilling a second outlet wellbore at the surface site;
 - drilling a third open hole lateral wellbore from the second inlet wellbore into the geothermal zone; and

- drilling, at a different depth than the third lateral wellbore, a fourth open hole lateral wellbore from the second outlet wellbore into the geothermal zone to the third lateral wellbore to allow fluid to circulate from the second inlet wellbore to the third lateral wellbore, from the third lateral wellbore to the fourth lateral wellbore, and from the fourth lateral wellbore to the second outlet wellbore.

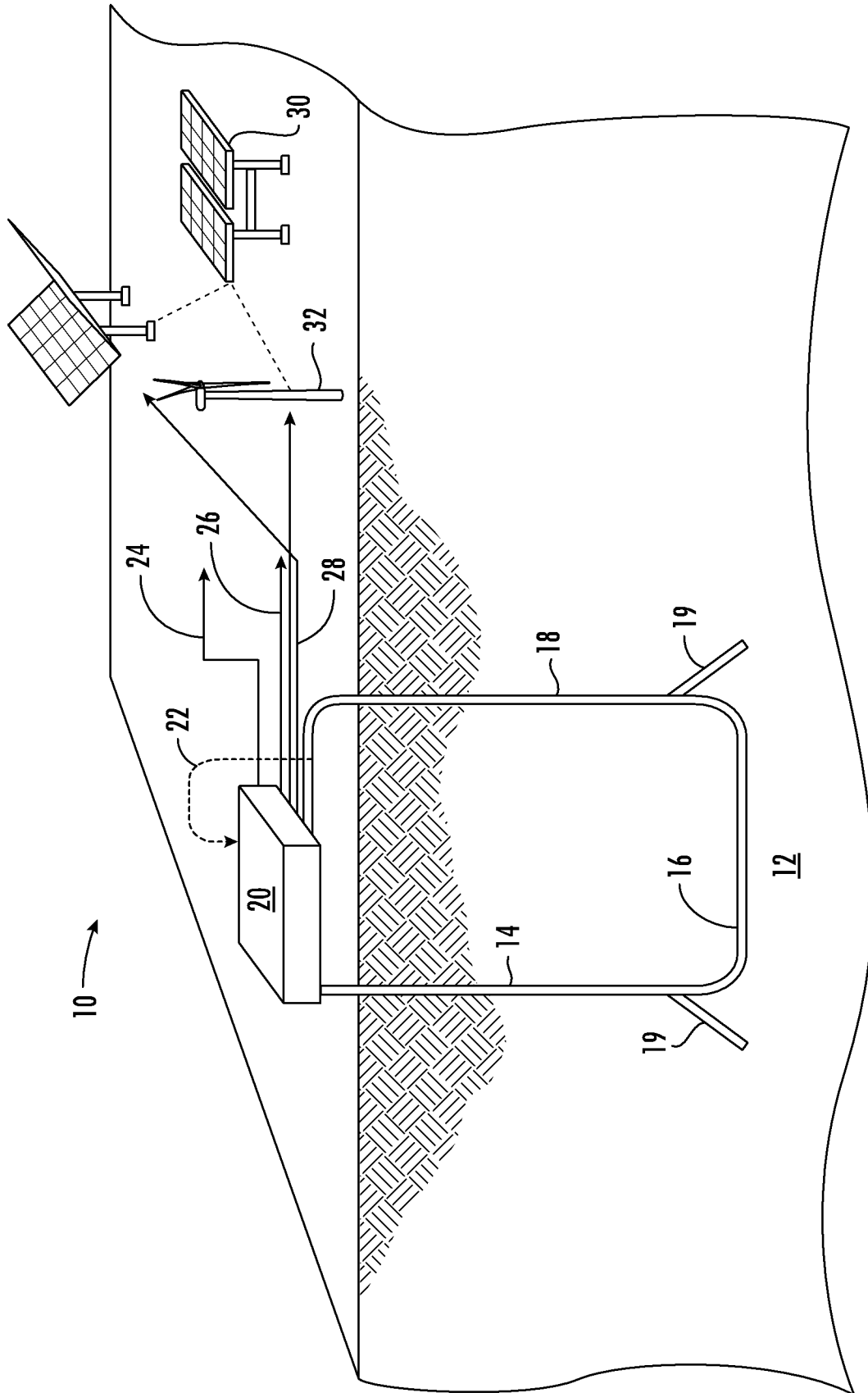

FIG. 1

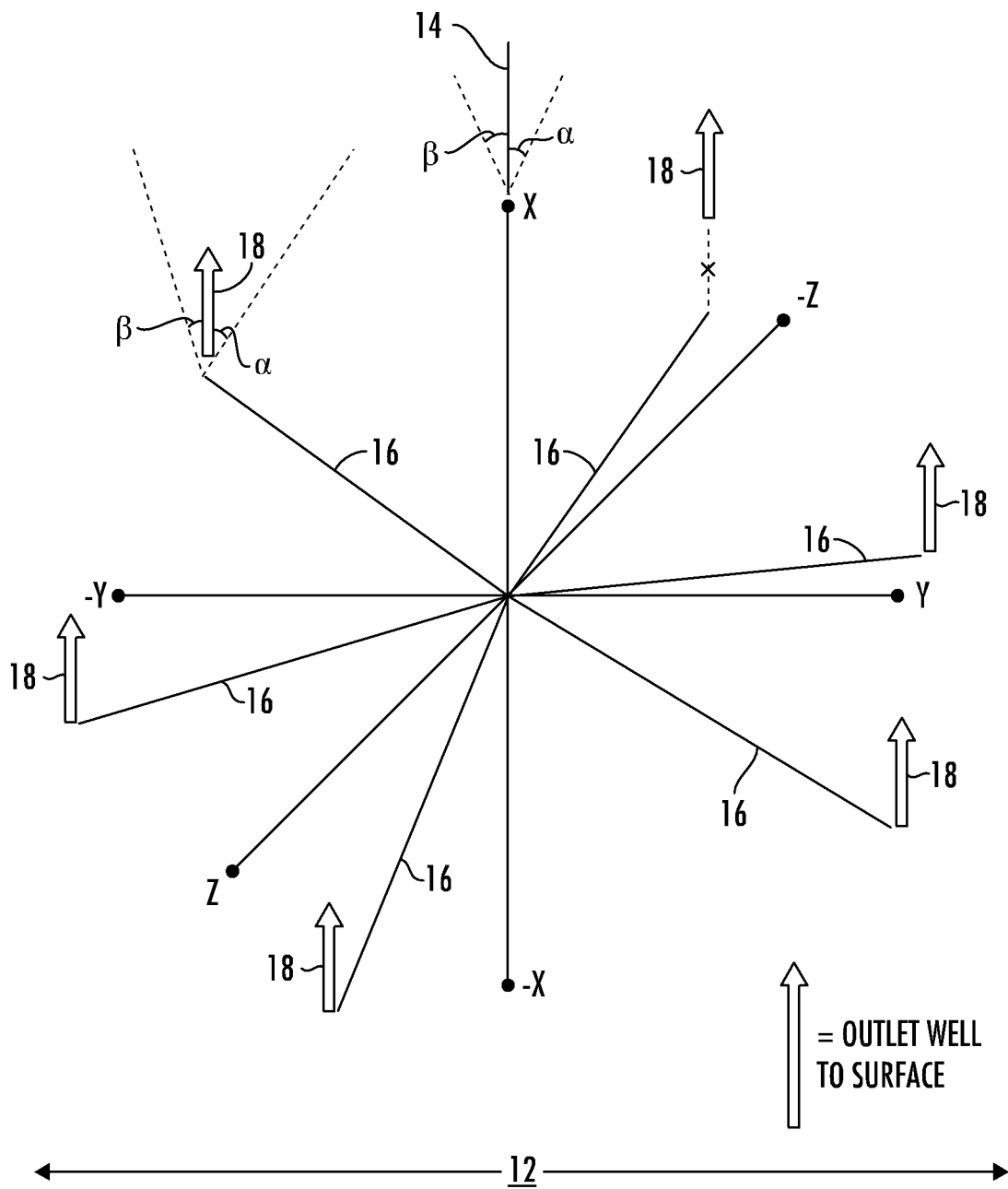
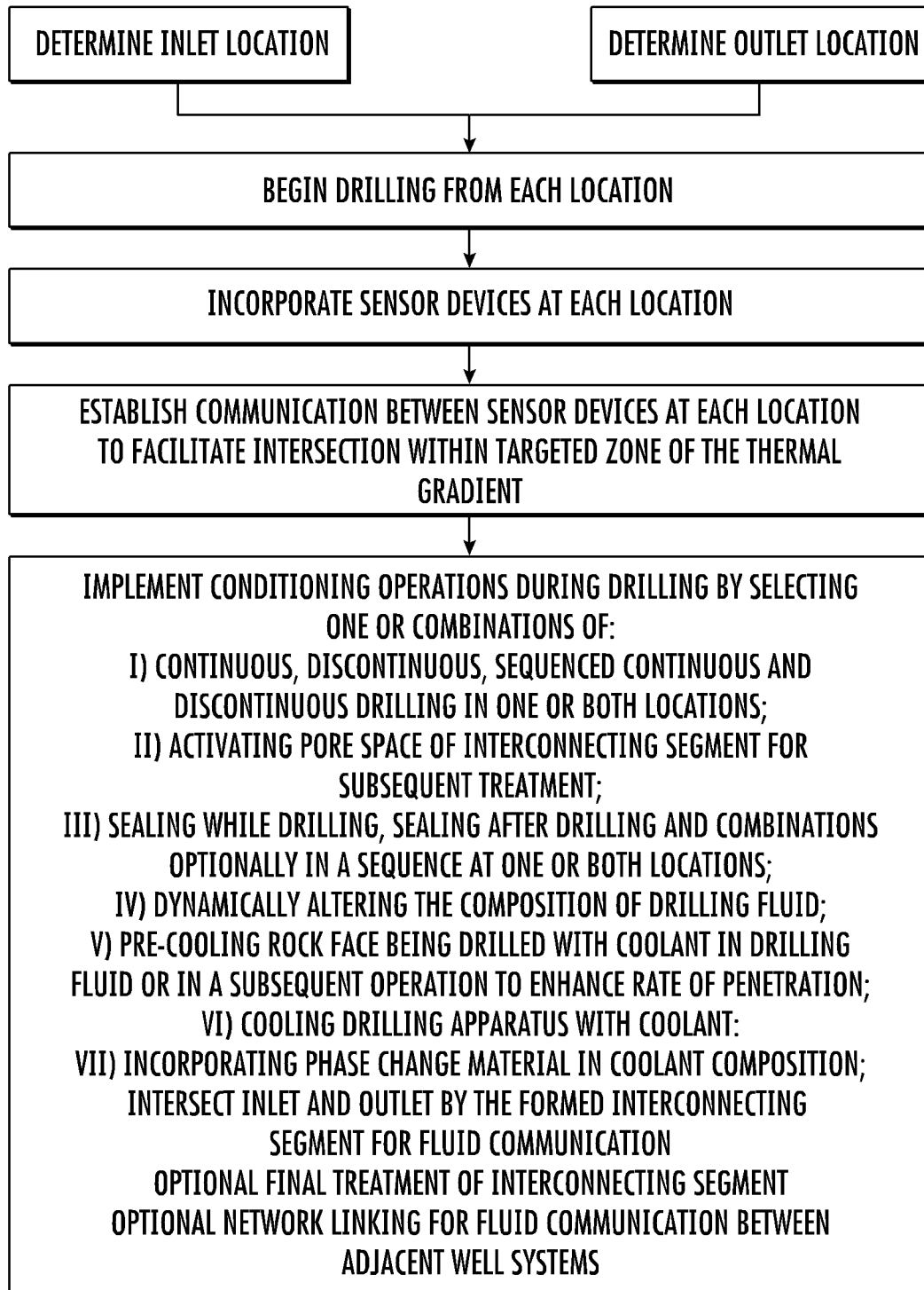

FIG. 2

**FIG. 3**

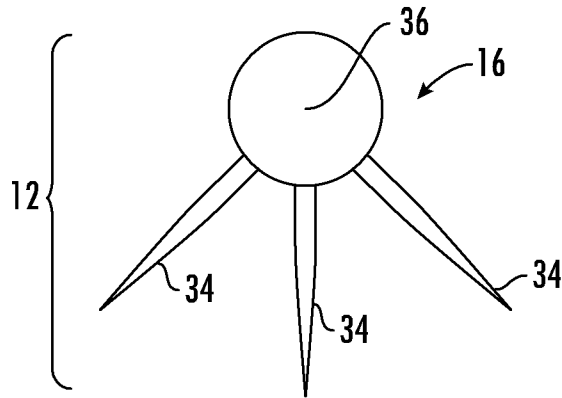

FIG. 4



FIG. 5

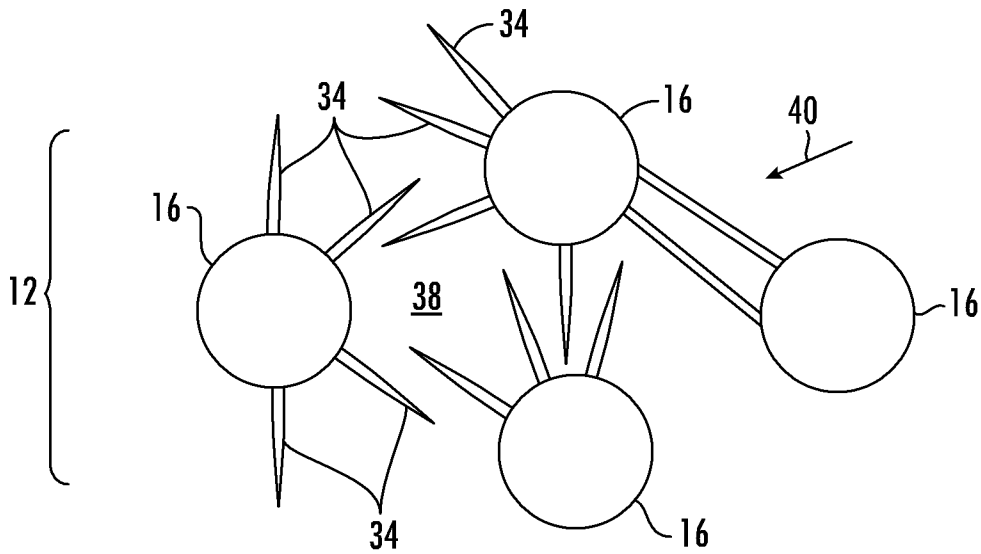

FIG. 6

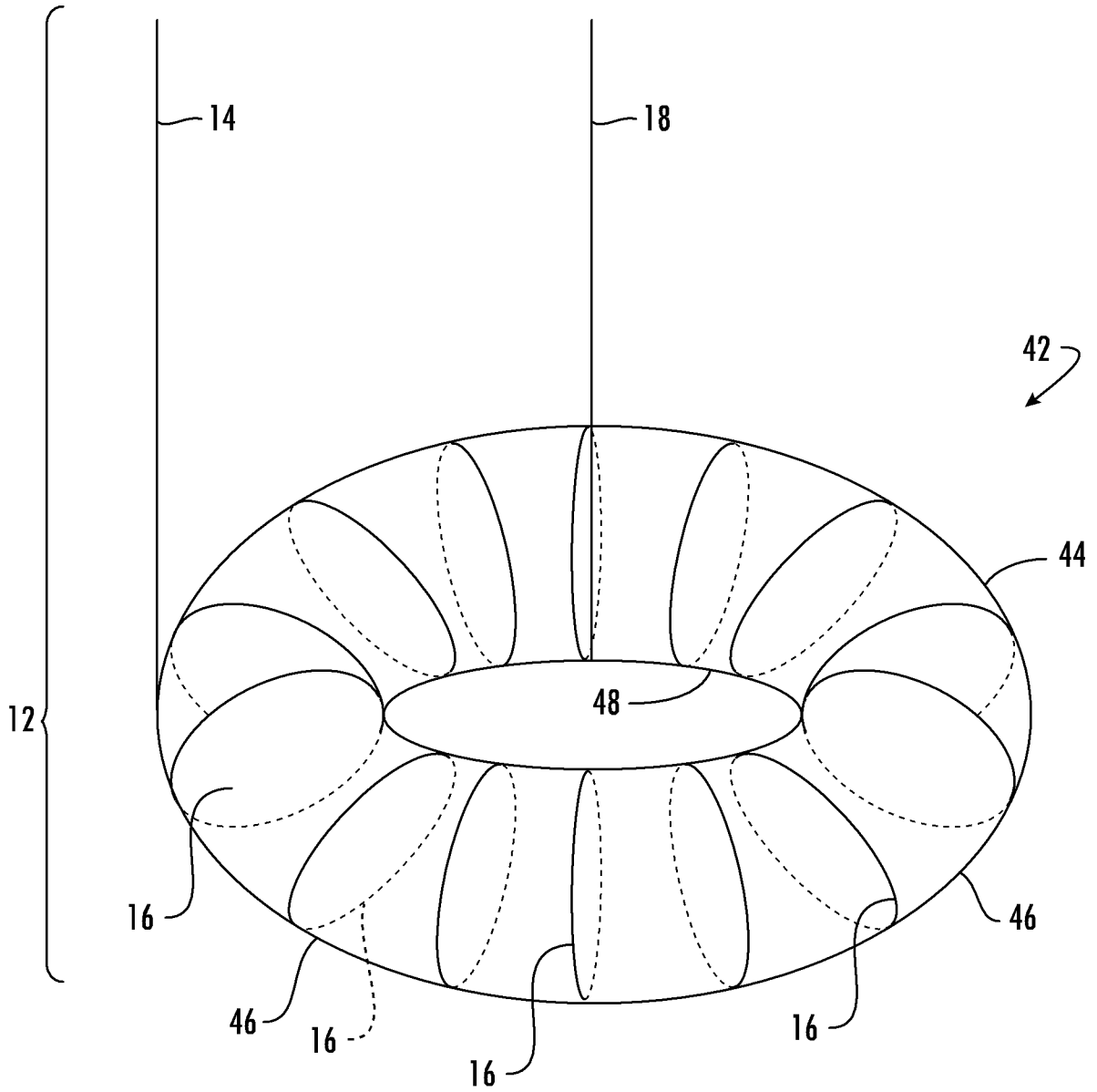
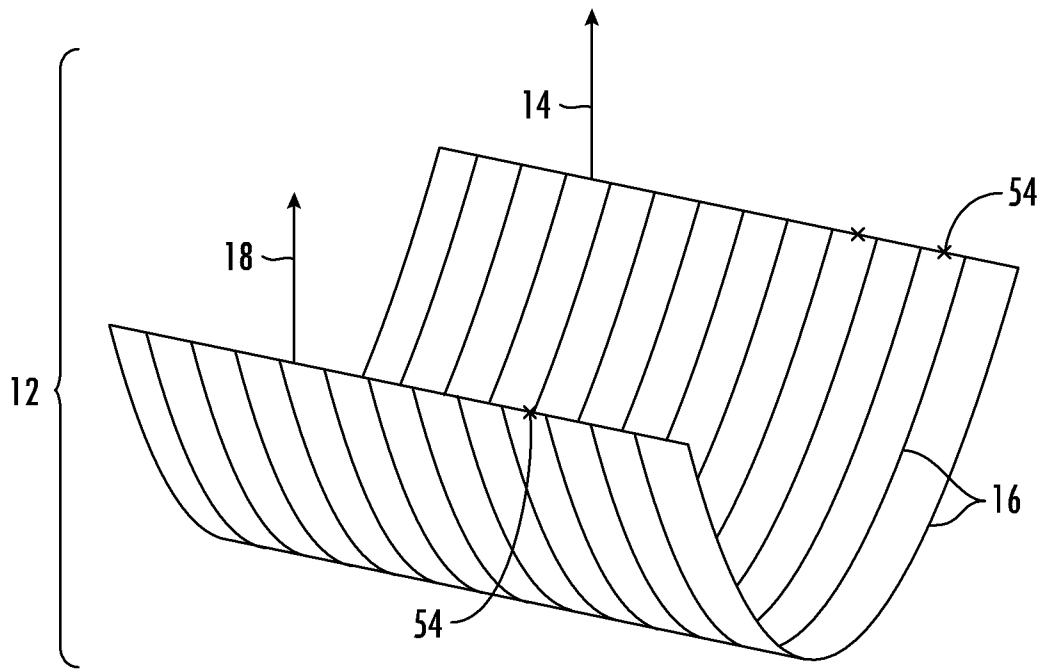
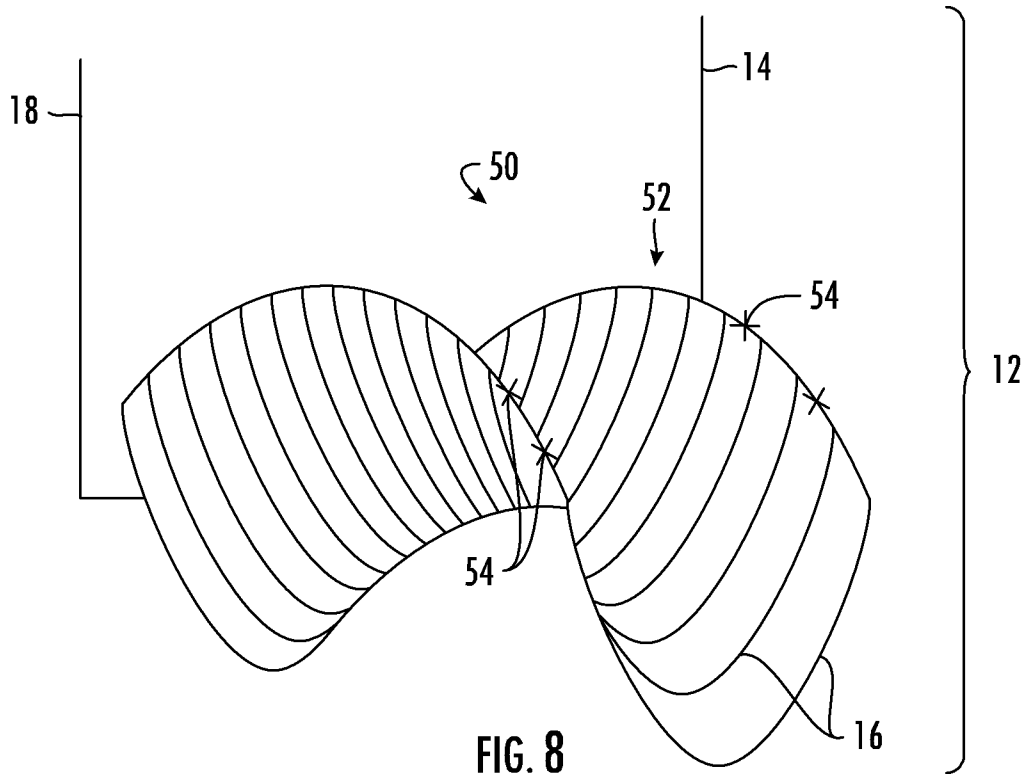

FIG. 7



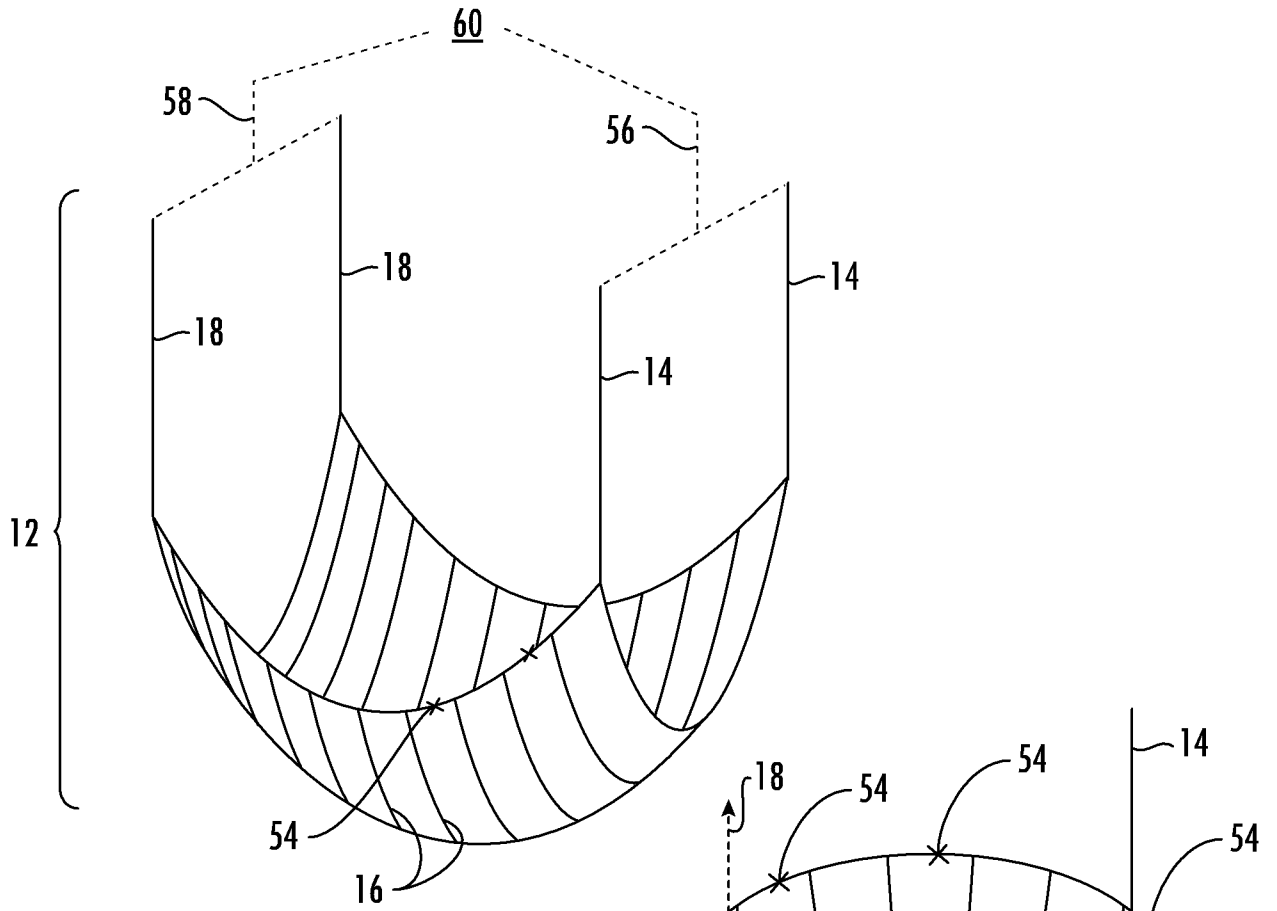

FIG. 10

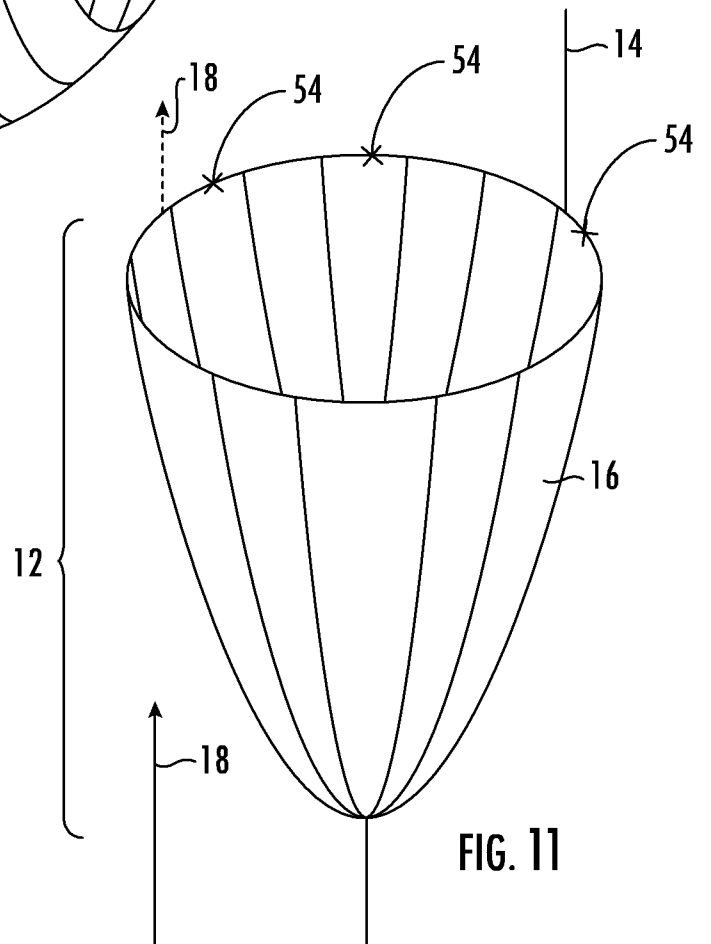

FIG. 11

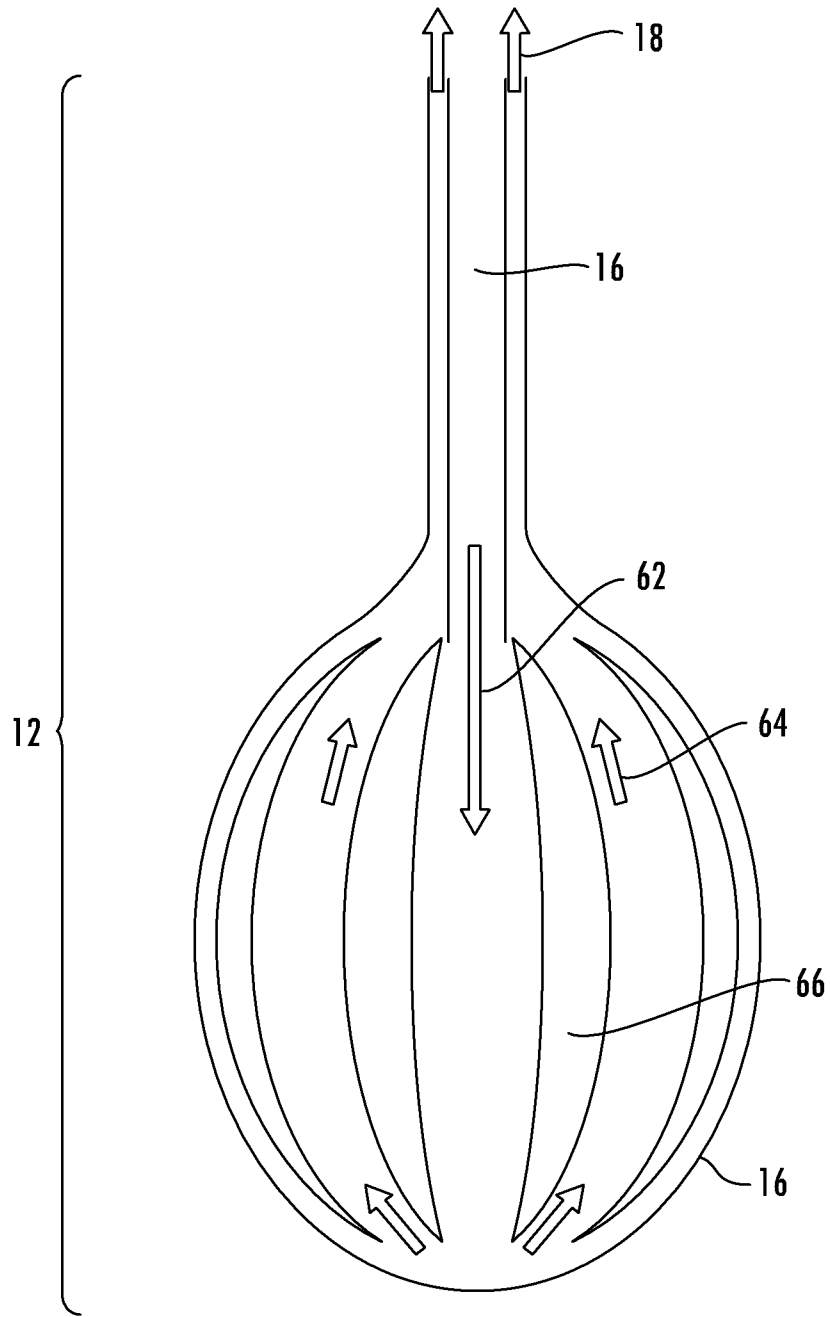

FIG. 12

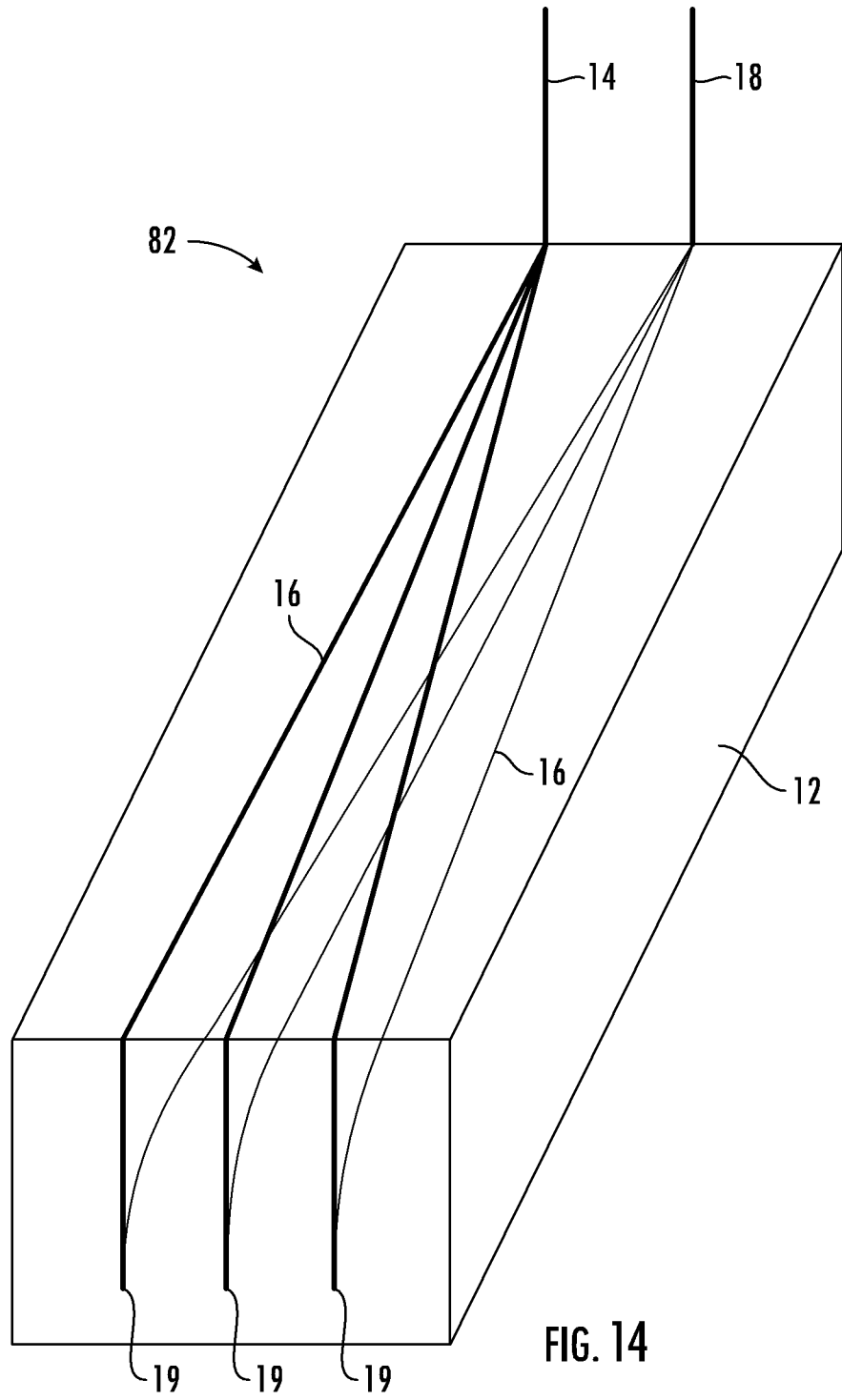

FIG. 14

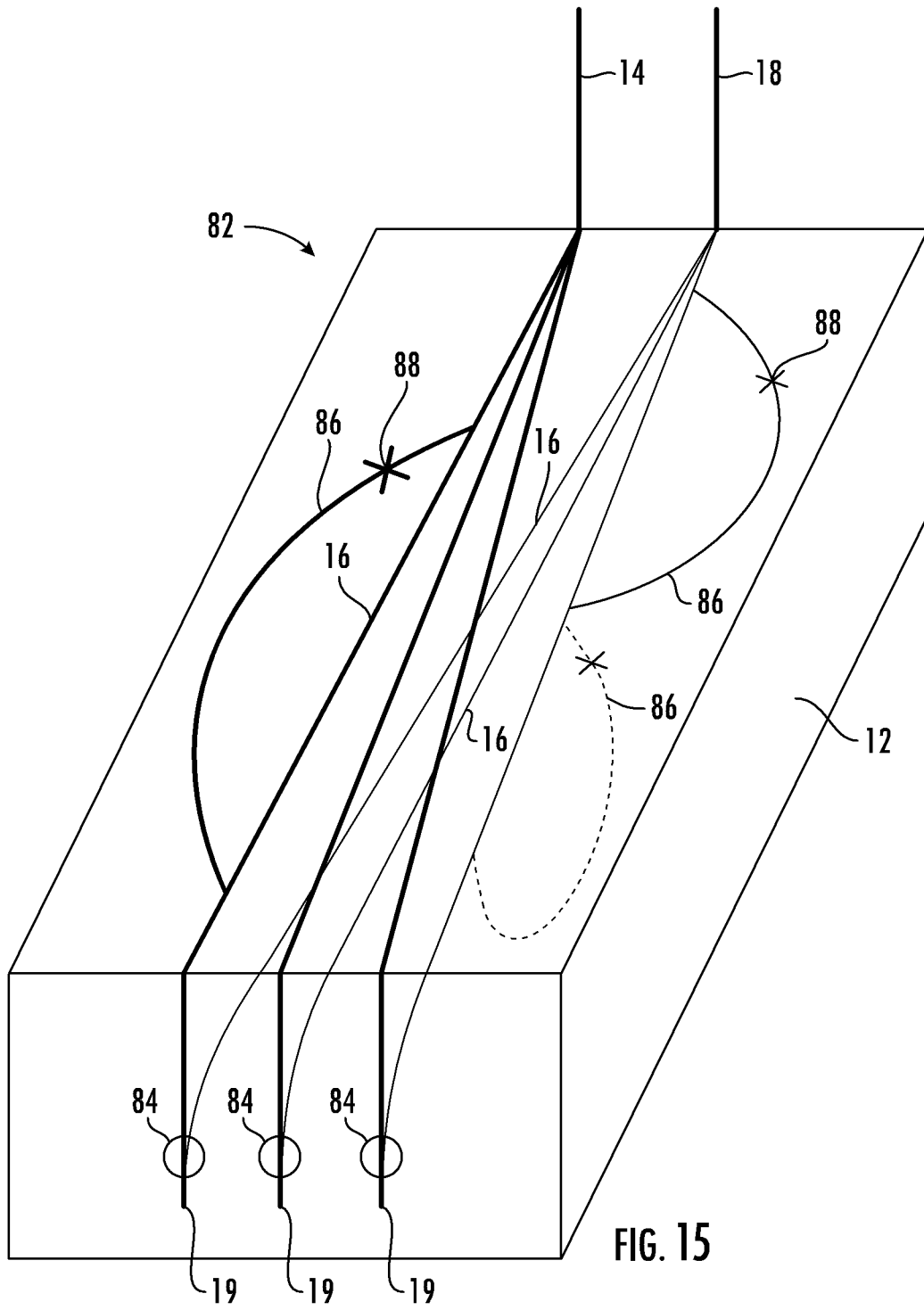

FIG. 15

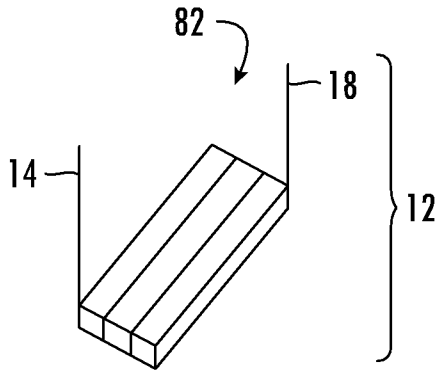

FIG. 16

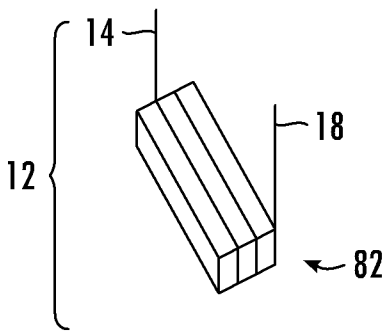

FIG. 16A

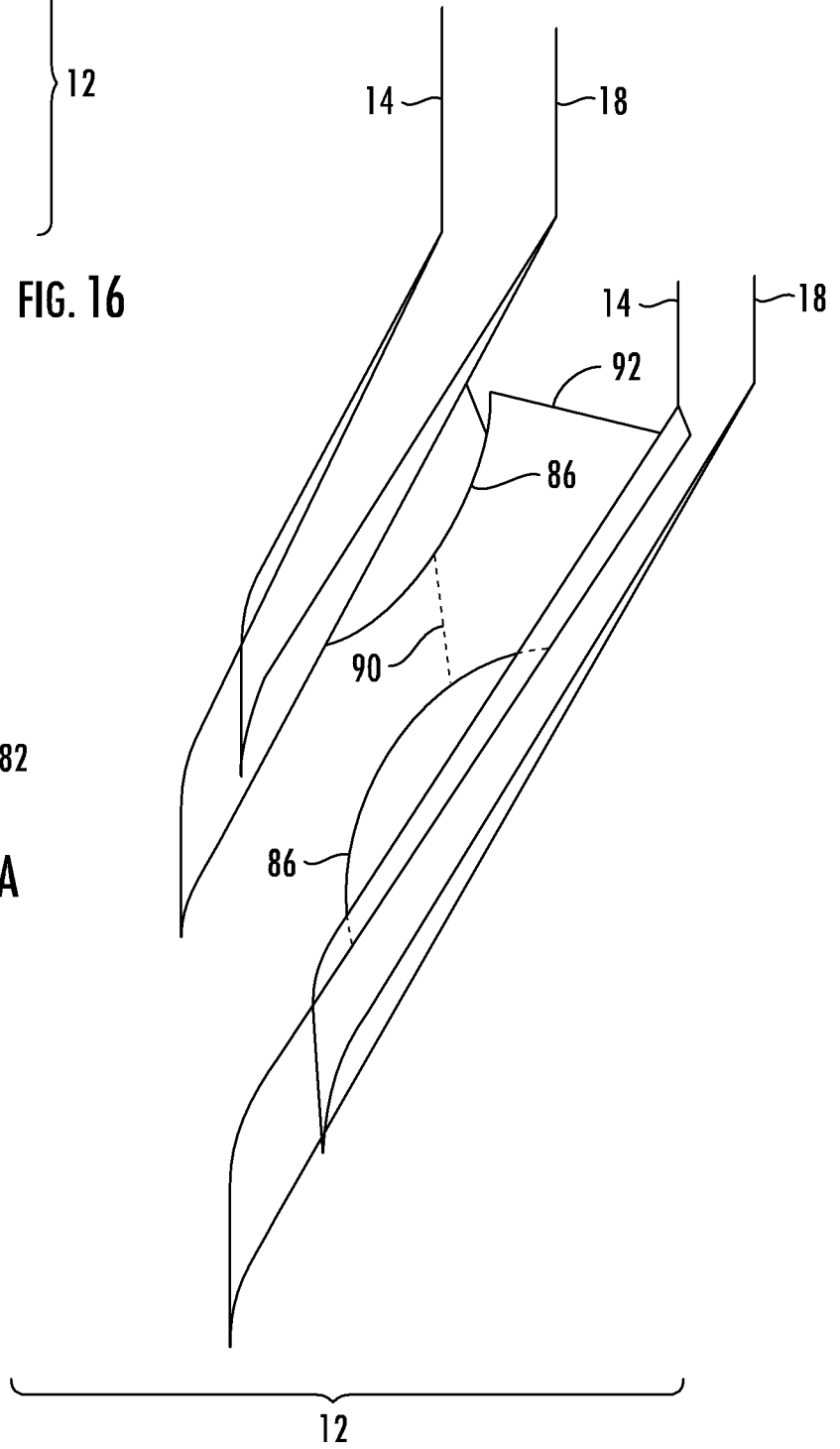

FIG. 17

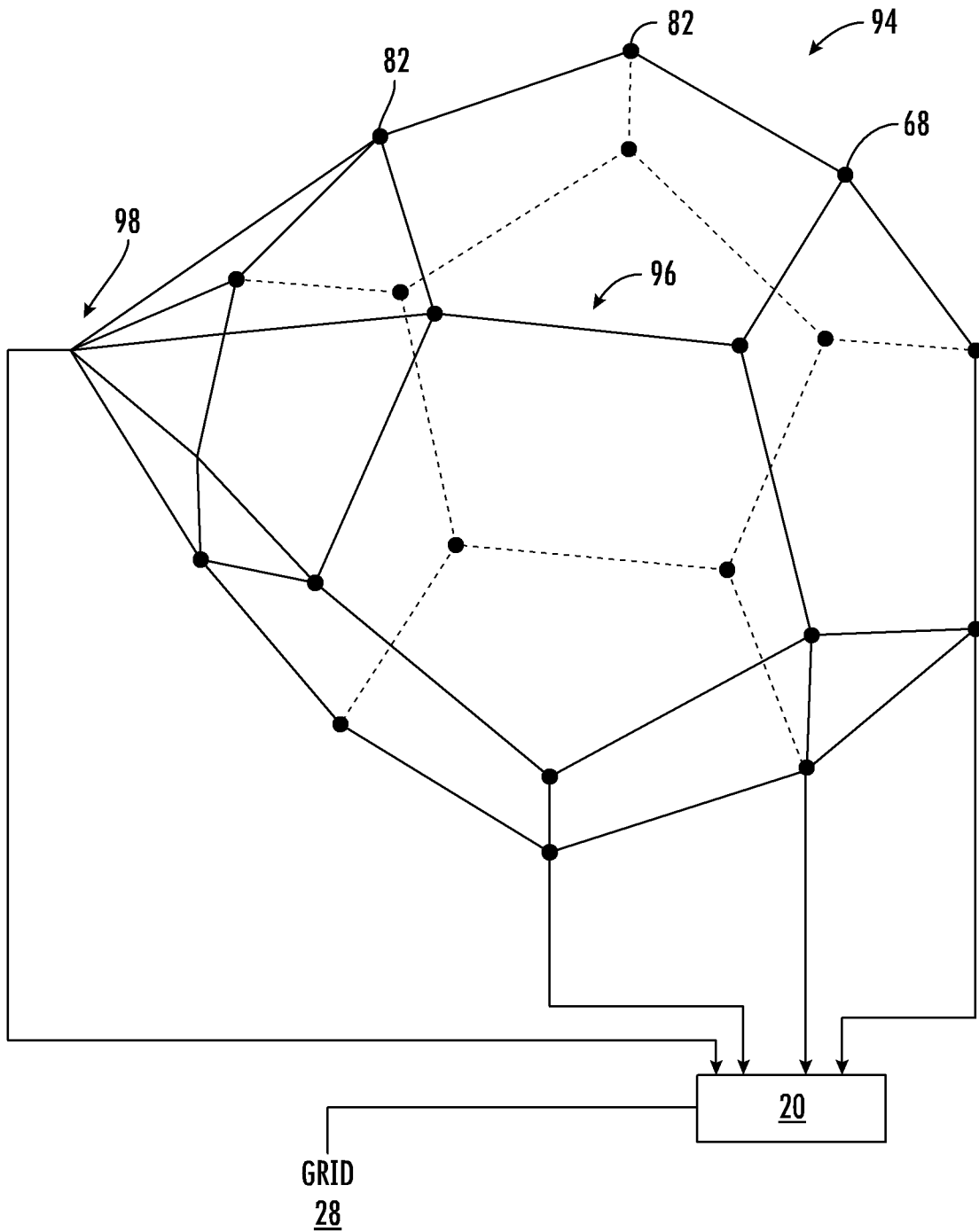

FIG. 18

