

Nov. 6, 1934.

M. P. JANISCH

1,979,468

DEVICE FOR RELIGHTING GAS RANGES

Filed Feb. 24, 1931

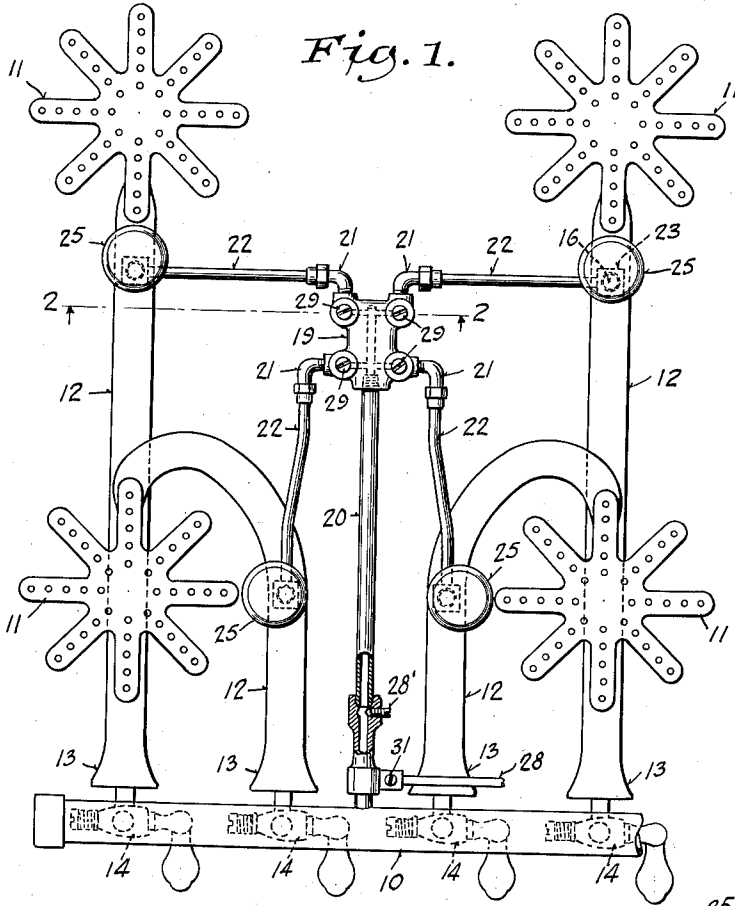

Fig. 1.

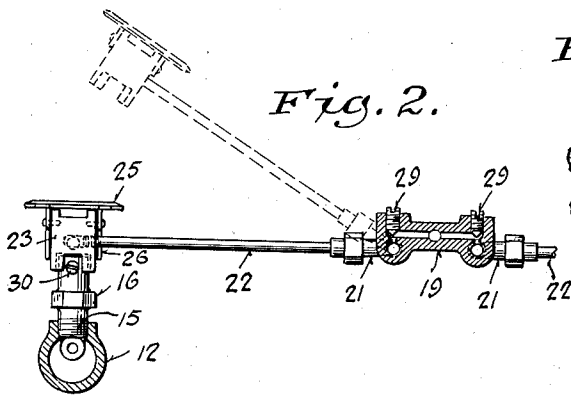

Fig. 2.

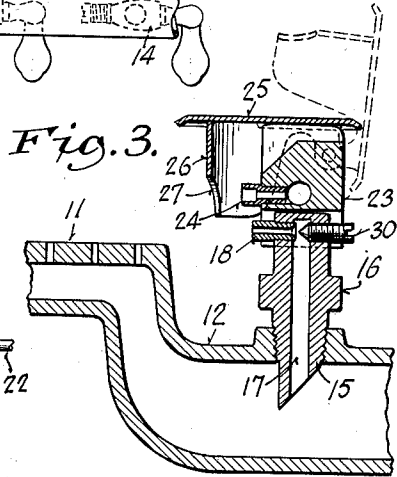

Fig. 3.

INVENTOR.

Maximilian P. Janisch

BY

W. J. Woolard

ATTORNEY.

UNITED STATES PATENT OFFICE

1,979,468

DEVICE FOR RELIGHTING GAS RANGES

Maximilian P. Janisch, Milwaukee, Wis., assignor
of one-half to Bride Janisch, Milwaukee, Wis.

Application February 24, 1931, Serial No. 517,883

4 Claims. (Cl. 158—115)

My invention relates particularly to gas ranges, such as are in general household use, and it resides in an attachment for gas ranges of this class which has for its purpose the automatic relighting of the gas at the burner of the range, in the event that the flame becomes extinguished accidentally. Such accidental extinguishment may be caused by the boiling over of a cooking vessel, or a gust of wind, and when such extinguishment occurs, the automatic relighting takes place, the invention then acting as a safety device to prevent the flow of unconsumed gas into the atmosphere. As is well known, asphyxiation of persons, as well as damage from explosions of accumulated gas, are serious results which sometimes follow the flow of unconsumed gas into the atmosphere surrounding the range.

Ordinarily, domestic gas ranges require close supervision to prevent the occurrence of disasters like those mentioned. There is also an ever present danger in the liability that the gas may be turned on accidentally, or by children, with like results, in ranges not equipped with an automatic relighting device.

I have spent considerable time and made extensive experimentation with a view of devising an automatic relighting and safety device which would eliminate the dangers mentioned, and at the same time comply with the regulations of the American Gas Association and other associations, in reference to what is to be tolerated in the construction of gas burners, with the result that I have now produced a device which acts automatically to relight the gas at the burners at all times, whether following extinguishment or the accidental or purposeful turning on of the flow of gas.

In my present invention, I equip the intake pipe connecting the burner with the supply of gas, with a perforated stud which is adapted to direct a fine jet of gas over the contiguous part of the burner, and associate therewith a constantly burning pilot, so that whenever gas is admitted to the intake pipe and emerges at the burner, the fine jet of gas emanating from the stud will be ignited by the pilot, and this in turn will ignite the gas at the burner. In the form in which I have illustrated my invention, the pilot is pivotally mounted so that it may be turned from its position of association with the stud before mentioned, and thus permit the ready removal and replacement of the burner and the attached intake pipe whenever it may be desirable or convenient to do so. The stud and the pilot together form a divided unit between the parts of which there is no fixed connection, but only one of co-operative association.

In a gas range having a plurality of burners, with a relighting pilot for each burner, the pilot gas is distributed from a central head, to which

the gas is supplied by an independent pipe connected to the manifold through which the gas is supplied to the several burners, the flow of gas from the manifold to the central head, and to the pilots, being unrestrained, except by certain regulating means, which may be adjusted to adapt the pilot to the use of any of the several different kinds of gases. Regulating means are also provided for controlling the volume of the gas constituting the fine jet of gas before mentioned.

Having thus outlined the nature and purposes of my invention, I will now describe the same in connection with the accompanying drawing, and will point out the novelty residing in the invention in the appended claims.

In the accompanying drawing:

Figure 1 is a plan view of an arrangement of a plurality of burners for a gas range, having associated therewith the required number of pilots, produced in accordance with my invention.

Fig. 2 is a vertical sectional view partly in elevation on the line 2—2, Fig. 1, looking in the direction of the arrows and showing some details of construction.

Fig. 3 is an enlarged sectional view showing a portion of a burner and the intake pipe therefor, with the stud and pilot associated therewith.

In the drawing the numeral 10 indicates the gas main or manifold from which gas is supplied to the several burners 11, through intake pipes 12, provided with bells 13, which form air mixing chambers. The flow of gas from the manifold 10 into the mixing chambers 13 is controlled by stopcocks 14.

The burner 11 and its intake pipe 12, is usually constructed as a one piece casting, and is arranged so that it may be easily placed in position and removed when desired. The upper side of the intake pipe 12 is perforated at a point in proximity to the burner for the reception of the threaded lower end 15 of an upstanding stud 16, perforated for the greater portion of its length, measured from its lower end, with a central bore 17 of small diameter. The closed upper end of the stud 16 is provided in approximately the plane of the face of the burner 11, with a small tubular section forming an igniting burner 18, the said small tubular section having an axial bore of small diameter extending therethrough.

The regulations of the gas associations before mentioned will tolerate the addition to the burner and its intake pipe, of the stud 16 arranged as described, but require such stud to be free from fixed association with any other part.

The arrangement illustrated comprises four burners, and this permits the convenient location of the pilot gas distributing head 19 in the center of the area defined by the said burners. A small pipe 20, threaded at one end into the head 19, is connected at its other end to the manifold 10, so

that gas may flow from the manifold directly to the head at all times, without restraint, other than that which may be imposed by the adjusting devices hereinafter to be referred to. The head 5 19 is provided with a bore in line with that of the pipe 20, but extending only partly therethrough, and with intersecting transverse bores opening outwardly and forming ports at four points on the head. Elbows 21 are threaded at one end into 10 the said ports, and are connected at the other end to small pipes 22 each of which carries at its free end a block 23 into which the free end of the pipe 22 is threaded. The passage through the pipe 20, head 19, pipe 22 and block 23, terminates 15 in a nozzle 24, formed of a section of pipe of small diameter, with a small bore extending there-through.

The block 23 is provided with a hinged cover 25, from the under side of which depends a curved skirt 26 provided in the axial line of the nozzle 24 with an uppercut notch 27. The length of the pipe 22 will be determined by the distance of the stud 16 from the head 19, and the block 23 is adapted to rest upon and be supported by the said stud, whereby the pilot is sustained in fixed 25 relation to the main burner which it serves. The pilots may be dissociated from the stud by simply lifting the tubes 22 and the elements at the free ends thereof, using the connection of the elbows 21 with the ports in the head 19, as swivels, in the manner shown by dotted lines in Fig. 2. At such times, the pilots are separated, and the integral burners 11 and their intake pipes 12 may be removed, as desired, without the disengagement of 30 any connected parts.

A lateral 28 may lead from the pipe 20 to a pilot light located in the oven.

In operation, gas flowing from the manifold 10 passes through the pipe 20 to the head 19, from which it is distributed to the pilots through the connections described. The small jets of gas emerging from the nozzles 24 may be lighted with or without turning the cover 25 from its full line operating position to its dotted line position in 45 Fig. 3, and when so lighted, the pilot light will burn so long as gas is turned into the manifold 10. When it is desired to light one of the burners 11, the controlling stopcock 14 is opened. The rush of gas through the intake pipe 12 to the burner, will be accompanied by the rise of a column of gas in the bore of the stud 16, and a small jet will be projected outwardly through the igniting burner 18. This jet will immediately be fired by the pilot flame present at the nozzle 24, and 50 in turn will ignite the gas flowing from the burner 11. Regulation of the flow of gas at the several outlets will be required to adapt the invention to the use of gases of varying characteristics and pressures. A needle valve 28' regulates the flow into the pilot supplying tube 20. Like valves 29 60 threaded into the head 19 at the ports thereof may be adjusted to control the flow of gas to the several pilots. A needle valve 30 threaded into the stud 16 in line with the fine perforation of the ignition burner 18, enables adjustment to be made at that point, and a similar valve 31 controls the flow into the lateral 28, leading to the oven.

The uppercut notch 27 removes a part of the depending skirt 26 from the zone of heat caused

by the combustion at the igniting burner 18 and the pilot nozzle 24. It will be seen that the cover 25 completely shields the pilot light and prevents extinguishment of the latter in the boiling over of a cooking vessel resting over the burner 11. The skirt 26 is of such extent as to prevent extinguishment of the pilot light by a gust of wind. It is preferable that the lower end 15 of the stud 16 be cut at an angle and positioned as shown in Fig. 3, to extend into the intake pipe 12, to better direct the flow of gas to the ignition burner. 80 85

Having thus described my invention, what I claim and desire to secure by Letters Patent of the United States, is:

1. In a gas range the combination of a main burner, an auxiliary igniting burner, and a gas supply pipe for both, all removable as a unit from the range, a pilot burner for igniting said auxiliary burner, a movable carrier for said pilot burner operable to place the latter in operative position adjacent said auxiliary burner, said carrier having means for supplying gas to said pilot burner, and a hood on said carrier for shielding both said auxiliary burner and said pilot burner when the latter is positioned adjacent the former, said carrier being movable to withdraw said pilot burner and said hood from said auxiliary burner to thereby provide ample clearance for ready removal of said main burner from the range. 90 95 100 105 110

2. In a gas range, a plurality of main burners each having a gas intake pipe provided with a port for the emission of a jet of gas in proximity to the main burner with which it cooperates, combined with a pilot gas distributing head disposed between the main burners, and a plurality of pilot gas burners pivoted to the distributing head, the said pilot gas burners being adapted to be operatively positioned with relation to the main burners to fire the respective jets and ignite the gas flowing from the contiguous main burner. 115 120 125

3. In a gas range, a plurality of main burners each having a gas intake pipe provided with a port for the emission of a jet of gas in proximity to the main burner with which it cooperates, combined with a pilot gas distributing head disposed between the main burners, and a plurality of pilot gas burners pivoted to the distributing head, the said pilot gas burners being adapted to be operatively positioned with relation to the main burners to fire the respective jets and ignite the gas flowing from the contiguous main burner, and protecting means carried by the pilot gas burners to prevent accidental extinguishment of the pilot lights. 130 135 140 145

4. In a gas range, a plurality of main burners each having a gas intake pipe provided with a port for the emission of a jet of gas in proximity to the main burner with which it cooperates, combined with a pilot gas distributing head disposed between the main burners, and a plurality of pilot gas burners pivoted to the distributing head, the said pilot gas burners being adapted to be operatively positioned with relation to the main burners to fire the respective jets and ignite the gas flowing from the contiguous main burner, protecting means carried by the pilot gas burners to prevent accidental extinguishment of the pilot lights, and means for regulating the pressure and volume of gas flowing to the several burners. 150

MAXIMILLIAN P. JANISCH. 145