

EUROPEAN PATENT SPECIFICATION

- ④ Date of publication of patent specification: **27.05.87** ⑤ Int. Cl.⁴: **H 01 R 23/68**
⑦ Application number: **82304749.3**
⑧ Date of filing: **09.09.82**

⑨ **Low or zero insertion force connector for multi-pin arrays.**

⑩ Priority: **15.09.81 US 302445**
23.07.82 US 401369

⑪ Date of publication of application:
27.04.83 Bulletin 83/17

⑫ Publication of the grant of the patent:
27.05.87 Bulletin 87/22

⑬ Designated Contracting States:
BE CH DE FR GB IT LI NL SE

⑭ References cited:
US-A-3 474 387
US-A-3 555 488
US-A-3 569 905

SOVIET INVENTIONS ILLUSTRATED, Section
R: Electrical, Abstracts, Week C06, 19th March
1980, Derwent, page SU-R5, London, GB.

⑮ Proprietor: **THOMAS & BETTS CORPORATION**
920 Route 202
Raritan New Jersey 08869 (US)

⑯ Inventor: **Christensen, Gordon D.**
662 Mary Evelyn Drive
San Jose Santa Clara California 95123 (US)
Inventor: **Donaher, Charles J.**
12799 Dianne Drive Los Altos Hills
Santa Clara California 94022 (US)

⑰ Representative: **Davy, John Raymond et al**
CARPMAELS & RANSFORD 43, Bloomsbury
Square
London, WC1A 2RA (GB)

Note: Within nine months from the publication of the mention of the grant of the European patent, any person may give notice to the European Patent Office of opposition to the European patent granted. Notice of opposition shall be filed in a written reasoned statement. It shall not be deemed to have been filed until the opposition fee has been paid. (Art. 99(1) European patent convention).

Description

Field of the Invention

This invention relates generally to electrical connectors and pertains more particularly to connectors of so-called zero or low insertion force type for use with multi-pin arrays.

Background of the Invention

The primary advantage in the use of zero insertion force connectors, namely, minimizing loading of interfitting contacts during connection, takes on particularly great significance as the number of contacts simultaneously made increases to levels today seen with circuit components produced by very large scale integration (VLSI) techniques. In this sector, a VLSI device may present a twenty-by-twenty pin array, i.e., a total of four hundred pins, for simultaneous individual mating with collectively supported sockets. The loading forces attending such connection are, of course, cumulative of the force per mating contact pair and can readily amount to a level which may be unattainable for an assembler or not sustainable by support housings of the respective pins and sockets.

A further problem presented to the connector designer by VLSI is that of readily facilitating connection and disconnection and while minimizing space in which such insertion connection and disconnection are to be effected. Customary practices in the art in larger environs are not applicable. In the above example of VLSI connection, the twenty-by-twenty pin array may be necessary within a square of about 50.8 mm (two inches) per side, i.e., about 2.5 mm (one-tenth inch) pin spacings in both column and row directions. Further connections may envision forty-by-forty pin arrays or more.

There are generally two types of zero insertion force connectors, one in which the contacts are normally closed and the other in which the contacts are normally open. The present invention relates to a zero or low insertion force connector having normally closed contacts. There are a number of known zero insertion force connectors of the closed-contact type which are used to make connection to conductors on printed circuit boards as well as to the leads of electronic packages or components and which employ camming devices for opening such contacts. Such connectors for printed circuit board connections are shown, for example, in US Patent Specification Nos: 4196955; 4159861; 4159154; 3553630; 3426313 and 3395377 and in German Patent Specification No: 1118852. References showing connections to a multipin device in a closed contact connector include US Patent Specification Nos: 4080032 and 4050758, the latter reference also being useful in connections to printed circuit boards.

US Patent Specification No: 3569905 discloses an electrical connector comprising a housing which supports a plurality of contacts having first and second terminals for respective connection

with an external circuit and with tabs on a printed circuit board. The second terminals have facing elements which are self-biased to define a normally open position for force free insertion of the circuit board tabs. Cam means are provided for deflecting the facing elements into a closed position to make mechanical and electrical contact between the facing elements and the circuit board tabs.

The present invention seeks to provide an improved connector for the interconnection of multi-pin arrays to corresponding contacts with zero or low insertion force.

In accordance with the invention, as set out in Claim 1, in one embodiment an electrical connector has a plurality of contacts having first and second terminals, the second terminals having facing elements which are closingly self-biased towards one another to electrically engage a pin to be received therebetween. The connector also has cam means which define a plurality of openings for receiving the second terminals and which has cam surfaces projecting into the openings and located between the facing elements. When the cam means is moved into a first position, the cam surfaces engage inner portions on the facing elements and cause the facing elements to diverge so that the pins can be readily received in the second terminals. The facing elements converge when the cam means moves into a second position, whereby the facing elements can then exert the full force of their self-bias on the pins.

In an embodiment of the invention, a cam actuator is provided for moving the cam means between its first and second positions, the cam actuator being movable in a direction transverse to the movement of the cam means.

Preferably, the cam means and cam actuator are plates, the cam plate being movable in an upward direction in response to lateral movement of the cam actuator plate. In this case, both the cam means and cam actuator plates comprise cooperating camming surfaces, each including a plurality of successively spaced, inclined cam ramps and slots for effecting movement of the cam means between its first and second positions.

Embodiments of the invention will now be described with reference to the accompanying drawings, in which:

Fig. 1 is an exploded perspective view of a connector showing both a VLSI device and a companion component to be connected thereby with the VLSI device.

Fig. 2 is a perspective view of a contact for use in the connector of Fig. 1.

Figs. 3—5 are respective front, side and top plan elevations of the Fig. 2 contact.

Fig. 6 is a plan elevation of a segment of the cam plate of the connector of Fig. 1 with one contact seated therein for purposes of explanation.

Fig. 7 is a partial sectional view of the cam plate of the connector of Fig. 1 as seen from plane VII—VII of Fig. 6.

Fig. 8 is a partial sectional view of the cam plate of the connector of Fig. 1 as seen from plane VIII—VIII of Fig. 6.

Fig. 9 is a sectional view as seen from broken plane IX—IX of Fig. 6 with the cam actuating pin, contact, VLSI device, device pin and companion apparatus being shown without sectioning for convenience and simplification of discussion.

Fig. 10 is a partial sectional view as seen from broken plane X—X of Fig. 6, with the contact, VLSI device, device pin and companion apparatus being shown without sectioning for like convenience and simplification of discussion.

Fig. 11 is a sectional view, as in Fig. 9, but with the cam plate in operative position, i.e., opposing socket element self-bias and displacing the socket elements to facilitate pin entry in the socket.

Description of the Preferred Embodiment

Fig. 1 depicts VLSI device 10 and companion apparatus 12 for connection thereto, for example, a printed circuit board (PCB). A connector for effecting such interconnection in accordance with the present invention comprises a housing having a base 14, defining compartment 16 upstanding from base floor 18 and bounded by side walls 20 and 22 and end walls 24 and 26. A cam plate 28 is shown above base 14. Cover or cap 30 of the housing has compartment 32 upstanding from cover floor 34 and bounded by side walls 36 and 38, end walls 40 and 42, and keying wall 44 which extends between side wall 36 and end wall 42. For assembly of connector parts, cover 30 has through-bores 46, 48, 50 and 52 and base 14 has suitably threaded registering bores 54, 56, 58 and 60. Fastener bolts (not shown) are passed through bores 46—52 and threaded into bores 54—60 for securing cover 30 to base 14, entrapping cam plate 28 within the housing.

VLSI device 10 has x—y dimensions compatible with like dimensions of compartment 32 of cover 30, with keying wall 10a oriented compatibly with keying wall 44 of cover 30. Pins 62 depend from undersurface 61 of VLSI device 10 in an x—y square array, of rows and columns, for example, a twenty-pin by twenty-pin predetermined array having a total of four hundred pins. Contacts 64 are supported in base 14 in the same array as pins 62 on floor 18. As will be seen in detail in enlarged views below, cam plate 28 has apertures 66 extending therethrough and arranged in the same array as the contacts 64. Cover 30 similarly includes passages 68 in such array, whereby contacts 64 may extend through cam plate 28 and cover 30 to be accessible from the upper exterior of the housing to receive pins 62.

Cam plate 28 has end wings 70 and 72 providing detents 74 and 76 for the retentive seating of inserts 78 and 80. Such inserts each have an interiorly threaded bore for receipt of exteriorly threaded cam actuating pin members 82 and 84. Cover 30 is provided with openings 86 and 88 for passage of members 82 and 84 therethrough. Members 82 and 84 are accessible exteriorly of the housing and are secured to cover 30, as by

use of snap rings (ring 85 also being shown in Fig. 9) applied thereto at the undersurface of cover 30. Upon such assembly of members 82 and 84 with cover 30 and subsequent fastening of cover 30 to base 14, as above discussed, the lower ends of members 82 and 84 seat freely in base recesses, one such recess being shown at 90.

As is described in detail below, members 82 and 84 function as position control means for cam plate 28, i.e., by turning the members, the plate may be disposed to confront base floor 18 or to confront the undersurface of cover 30.

Turning now to Figs. 2—5, contact 64 has a first terminal 64a which extends through base 12 to be accessible below the base for engaging a terminal of companion apparatus, e.g., terminal 64a may be wave soldered to a conductive strip on PCB 12 (Fig. 1). Terminal 64a may also be formed in straight downward configuration for insertion into suitable metallized openings provided in PCB 12 and soldered therein by conventional wave-flow soldering techniques. A second terminal, serving as a pin-receiving socket, is provided opposite such first terminal and is defined by facing elements 64b and 64c which are formed in self-biased preselected attitude to assume generally parallel stance (Fig. 3). Contact 64 is formed by beryllium copper, phosphorous bronze or like material having sufficient resilience to exhibit self-bias, whereby facing elements 64b and 64c will seek to return to such parallel relation, or other preselected self-biased attitude, after release from mutually outward forces thereon opposing such inward self-bias.

Lances 64d and 64e are struck from elements 64b and 64c to extend inwardly thereof and preferably have arcuate facing surfaces at ends 64d—1 and 64e—1. A central support section 64g and an outwardly flared upper pin entry section 64f complete the contact, parts 64f—1 and 64f—2 flowing arcuately as shown to define inturned undersurfaces 64f—3 and 64f—4 inboard of facing elements 64b and 64c.

One such contact 64 is shown in conjunction with cam plate 28 in Fig. 6, which is a view enlarged approximately twenty times actual size for the two-inch square, twenty-by-twenty array alluded to above. A contact 64 would, of course, be resident in each of plate apertures 66, but such other contacts are here omitted for convenience and to simplify exposition. The segment of plate 28 shown in Fig. 6 includes apertures 66a through 66p, each of which has identical outline, as now discussed for aperture 66b.

Considering Figs. 6—8 jointly with Figs. 2—5, wall 92 and the left side walls of cam elements 94 and 96 provide a residence channel for contact facing element 64b. Similarly, right wall 98 and the right side walls of cam elements 94 and 96 provide a residence channel for contact facing elements 64c. Contact lances 64d and 64e are situated in a non-interference path with plate 28, being of expanse less than the spacing across the aperture between opposed cam elements 94 and 96. Conversely, the cam elements extend margi-

nally into the space 64h between contact facing elements 64b and 64c. Accordingly, if plate 28 were to be moved forward out of the plane of Fig. 6, contact 64 remaining fixed, cam surfaces 94a and 96a would engage contact undersurfaces 64f—3 and 64f—4 and oppose the self-bias of facing elements 64b and 64c to displace same outwardly of each other.

As cam plate 28 is actually disposed in the plane of Fig. 6, the cam surfaces are inactive, being remote from the cammed contact surfaces 64f—3 and 64f—4, this condition of the connector being further seen in Figs. 9 and 10. Here, member 82 is rotated fully counterclockwise in insert 78, placing cam plate 28 in its lowermost position, adjacent base floor 18. In such cam inoperative position, contact facing elements exert the full force of contact self-bias upon pin 62 therebetween.

The converse condition of the connector, i.e., cam operative position, is seen in Fig. 11. Here, member 82 is rotated fully clockwise in insert 78, placing cam plate 28 in its uppermost position, adjacent cover 30. In such cam operative position, contact self-bias is opposed and contact facing elements are displaced outwardly of one another, bending elastically about the locations of their exit from base apertures 100. Pin 62 is readily inserted into contact 64 under this condition and is shown in such seated condition.

The extent of deflection of facing elements 64b and 64c in the cam operative position may be readily established by selection of the width (W in Fig. 7) of cam elements 94 and 96, once the configuration of contacts 62 is established. Thus, while Fig. 11 shows a zero insertion force condition, the contact lances being non-contiguous with pin 62, advantage attends a low, rather than zero, insertion force. Thus, the invention prefers selection of cam element and contact dimensions to provide, in the cam operative position, for the spacing between opposing lance end surfaces from one another to be less than the diameter of pin 62. The lance end surfaces thus frictionally slidably engage pin 62 upon insertion giving rise to measurable insertion force. The lance end surfaces are preferably arcuate, as noted above. Upon release of the opposing force exerted on the facing contact elements 64b and 64c by the cam plate 28, the lances 64d and 64e, under the influence of the self-bias force of the contact, provide a further wiping action as between such arcuate surfaces and the pins. By virtue of the pin wiping action, surface oxides may be removed and gas-tight electrical connection readily realized.

Various modifications to the foregoing disclosed connector will be evident to those skilled in the art and may be introduced without departing from the invention. For example, alternative camming mechanisms may be used to reduce the connector profile or to enhance its strength by resisting bowing, especially in connectors with greater numbers of connections, such as in forty-by-forty pin arrays. In an electronic component

such as a VLSI device similar to the device 10 of Fig. 1 and having a plurality of terminal pins projecting from the undersurface of the device and companion apparatus for connection thereto, for example, a printed circuit board (PCB), an alternative approach for effecting such interconnection in accordance with the present invention includes a connector comprising a housing including a base having a compartment defined by upstanding side walls, end wall and floor. The undersurface of the base may include a plurality of longitudinally extending ribs that provide stiffness to the base while permitting a minimal thickness.

A cam actuator is configured in the form of an elongate plate within the base compartment for sliding longitudinal movement relative thereto. The undersurface of the cam actuator includes a plurality of longitudinally extending, laterally spaced teeth that are adapted to slide within a like plurality of tracks formed in the base floor. Movement of the cam actuator is effected by an actuator pin having a shaft and an eccentric portion. The shaft is adapted to be received in an aperture in the base and the eccentric portion is captively retained in an elongate opening provided through a solid portion of the cam actuator. The opening is formed to closely receive the eccentric portion such that upon rotation of the pin, the eccentric portion will engage the walls of the cam actuator adjacent the opening and move the cam actuator plate longitudinally relative to the base. A slot is provided in the upper surface of the pin shaft to receive a screwdriver or like instrument for facilitating rotation of the pin.

The cam actuator, in its preferred form, includes a plurality of fingers extending longitudinally from the cam actuator solid portion and terminating in free ends. Each of the fingers is laterally spaced by an opening. The upper surface of each finger is a camming surface and includes thereon a plurality of inclined cam ramps and slots, successively spaced in the longitudinal direction and described in more detail hereinbelow. The free ends of the fingers are adapted to be slidably received in corresponding openings provided in the end wall of the base upon movement of the actuator.

A cam plate overlies the cam actuator, the cam plate being adapted to fit within the compartment of base and to move vertically relative thereto. The bottom surface of the cam plate is a camming surface and comprises a plurality of laterally spaced, longitudinally extending rows of inclined cam ramps and slots that are adapted to cooperate with the cam ramps and slots on the cam actuator plate. Movement of the cam plate is restricted to the vertical direction by the base end wall and a front wall of a cap that is secured to the base as by screws. Tabs project from the cam plate and slide vertically within slots in the rear wall while the tabs slide vertically within slots in the front wall in the cap. The cap further includes an aperture for receiving the shaft of the pin for external access thereto. For assembly of the cap

5

10

15

20

25

30

35

40

45

50

55

60

65

to the base, the cap has apertures and the base has suitably threaded registering bores. In the preferred form, the base, cam actuator, cam plate and the cap are made of a suitably rigid plastic material.

The latter mentioned VLSI device has X—Y dimensions compatible with the base and the base has internal ledges to support the VLSI device in the connector. The pins depend from the undersurface of the VLSI device in an X—Y square array of rows and columns, for example, a twenty-pin by twenty-pin predetermined array having a total of four hundred pins. A like number of contacts are supported in the base in a like array of apertures provided in the base floor. The cam plate has apertures extending therethrough and arranged in the same array as the contacts. The contacts project upwardly from the base through lateral openings between the fingers and into the apertures in the cam plate. The contacts may receive the terminal pins between their biased facing elements without the lances as described with reference to Figs. 2—5.

In operation, rotation of the pin provides longitudinal movement of the cam actuator which, in turn, with the cam ramps of the cam plate riding on the cam ramps of the cam actuator provides vertical upward or downward movement of the cam plate within the connector. Cam surfaces disposed within the apertures, similar to those described with reference to the arrangement in Figs. 6—8 hereinabove, move the contacts to an open position to freely receive the terminal pins therein. Camming plates having such apertures constructed to receive both the contact facing elements and the VLSI terminals while defining partial boundaries about the VLSI pins contribute to the low profile of the connector.

It should be noted that the latter mentioned connector arrangement as described herein places both the cam plate and cam actuator in compression against the bottom floor of the base under the influence of the spring force of the contacts. Such construction substantially minimizes the problems of bowing or bending of the cam plate upon movement upward to spread apart the contact elements. As a result, a larger array of pins than in the known art having very close centers in both row and column directions (e.g., 2.5 mm by 2.5 mm) can be accommodated without problems of the strength of the material or the stiffness of the cam plate itself.

Having described the construction and operation of the connectors herein, it should now be appreciated that multi-pin connections between the pins of a VLSI device and a companion PCB may be readily effected with zero or low insertion force. The particularly described arrangements are intended to be illustrative and not limited thereto. The true scope of the invention is set forth in the following claims.

Claims

1. An electrical connector for interconnecting a

plurality of terminal pins (62) in a predetermined array to companion apparatus (12) comprising:

(a) a housing;

(b) a plurality of contacts (64) supported by said housing in said array and extending in a common direction, each said contact (64) having a first terminal (64a) for connection to said companion apparatus (12) and a second terminal adapted for receiving one such terminal pin (62) and having facing elements (64b, 64c) which are self-biased to return to a preselected attitude, and

(c) cam means (28) having cam surfaces (94a, 96a) and supported for movement in said housing in said common direction, said cam means (28) defining a plurality of openings (66) in which said second terminals are received, said cam means (28) being movable between a first position, wherein said cam surfaces (94a, 96a) engage said facing elements (64b, 64c) of all such second terminals to oppose such self-bias thereof and displace said facing elements (64b, 64c) from said preselected attitude, and a second position, wherein said cam surfaces (94a, 94b) do not oppose said second terminal self-bias,

characterised in that said cam surfaces (94a, 96a) project into said openings (66) and are located between said facing elements (64b, 64c) so that when said cam means (28) is moved into its first position, said cam surfaces (94a, 96a) engage inner portions (64f 1—4) of said facing elements (64b, 64c) and thereby cause said facing elements (64b, 64c) to diverge to enable said pins (62) to be readily received in said second terminals; said facing elements (64b, 64c) converging when said cam means (28) moves into its second position, whereby said facing elements (64b, 64c) can exert the full force of said self-bias upon the pins (62) therebetween.

2. An electrical connector according to claim 1, wherein each of said openings (66) fully bound individual contacts (64) and wherein the cam surfaces (94a, 96a) are collectively movable.

3. An electrical connector according to claim 1, wherein said cam means (28) comprises a plate member, defining said plurality of openings (66) therethrough, each opening (66) being in registry with said second terminals in receiving such second terminals therein, said housing supporting said plate member for movement in said common direction.

4. An electrical connector according to claim 3 wherein said plate member defines said cam surfaces (94a, 96a), said cam surfaces (94a, 96a) partially bounding each such opening (66) and being in interference path with the facing elements (64b, 64c) in each said opening (66) to engage the same in the course of movement of said plate member into said first position.

5. An electrical connector according to claim 3, wherein said cam surfaces (94a, 96a) for each such opening (66) are resident respectively in said second terminals throughout the course of movement of said plate member between said first and second positions.

6. An electrical connector according to claim 1,

further including cam actuator means movable in a direction transverse to said common direction for moving said cam means between said first position and said second position.

7. An electrical connector according to claim 6, wherein said cam means and said cam actuator means comprise co-operating adjacent camming surfaces for effecting movement of said cam means, and wherein said camming surfaces of said cam means and said cam actuator means each comprise a plurality of opposed co-operating inclined cam ramps and slots successively spaced on each camming surface.

8. An electrical connector according to claim 7, wherein said cam means comprises a plate member overlying said cam actuator means, and having a lower surface comprising said inclined cam ramps and slots, said housing supporting said plate member for movement in said common direction, and wherein said cam actuator means comprises a plate element underlying said plate member and having an upper surface comprising said inclined cam ramps and slots, said housing supporting said plate element for transverse sliding movement; the inclined cam ramps of said plate member and plate element respectively terminating in flat surfaces, said flat surfaces of co-operating cam ramps being in contact when said plate member is in said first position and said flat surfaces being disposed in opposing slots when said plate member is in said second position.

Patentansprüche

1. Ein elektrischer Verbinder zum Anschließen einer Vielzahl von Anschlußstiften (62) in einer vorgegebenen Anordnung an ein zugehöriges Gerät (12) aus:

(a) einem Gehäuse;

(b) einer Vielzahl von durch das Gehäuse in der besagten Anordnung abgestützten und in einer gemeinsamen Richtung verlaufenden Kontakten (64), wobei jeder Kontakt (64) einen ersten Anschluß (64a) zum Anschließen an das zugehörige Gerät (12) und einen zweiten zur Aufnahme des einen Anschlußstiftes (62) geeigneten Anschluß aufweist, und sich gegenüberliegende Elemente (64b, 64c) aufweist, die zwecks Rückkehr in eine vorgewählte Stellung unter Eigenspannung stehen, und

(c) einem Nockenmittel (28), das Nockenflächen (94a, 96a) aufweist und zur Bewegung in dem Gehäuse in der gemeinsamen Richtung abgestützt ist, wobei das Nockenmittel (28) eine Vielzahl von Öffnungen (66) umschließt, in denen die zweiten Anschlüsse aufgenommen werden, wobei das Nockenmittel (28) zwischen einer ersten Stellung, in der die Nockenflächen (94a, 96a) an den sich gegenüberliegenden Elementen (64b, 64c) von allen diesen zweiten Anschlüssen anliegen, um sich damit deren Eigenspannung zu widersetzen und die sich gegenüberliegenden Elemente (64b, 64c) aus der vorgewählten Stellung zu verschieben, und einer zweiten Stellung bewegbar ist, in der sich die Nockenflächen (94a,

94b) der Eigenspannung der zweiten Anschlüsse nicht widersetzen,

dadurch gekennzeichnet, daß die Nockenflächen (94a, 96a) in die Öffnungen (66) hineinstehen und zwischen den sich gegenüberliegenden Elementen (64b, 64c) angeordnet sind, so daß die Nockenflächen (94a, 96a) bei einer Verschiebung des Nockenmittels (28) in dessen erste Stellung an den Innenabschnitten (64f 1—4) der sich gegenüberliegenden Elemente (64b, 64c) anliegen und damit bewirken, daß diese sich gegenüberliegenden Elemente (64b, 64c) divergieren, damit die Stifte (62) ohne weiteres in den zweiten Anschlüssen aufgenommen werden können; und wobei die sich gegenüberliegenden Elemente (64b, 64c) konvergieren, wenn sich das Nockenmittel (28) in seine zweite Stellung bewegt, so daß die sich gegenüberliegenden Elemente (64b, 64c) die volle Kraft der Eigenspannung auf die dazwischen befindlichen Stifte (62) ausüben können.

2. Ein elektrischer Verbinder gemäß Anspruch 1, wobei jede der Öffnungen (66) einzelne Kontakte (64) völlig umschließt und wobei die Nockenflächen (94a, 96a) kollektiv verschiebbar sind.

3. Ein elektrischer Verbinder gemäß Anspruch 1, wobei das Nockenmittel (28) ein Plattenglied ist, das die Vielzahl der durchtretenden Öffnungen (66) umschließt, jede Öffnung (66) mit den zweiten Anschlüssen bei deren Aufnahme in sich in Deckung liegt, und das Gehäuse das Plattenglied zur Bewegung in der gemeinsamen Richtung abstützt.

4. Ein elektrischer Verbinder gemäß Anspruch 3, wobei das Plattenglied die Nockenflächen (94a, 96a) ausbildet, die Nockenflächen (94a, 96a) jede dieser Öffnungen teilweise umschließen und mit den sich gegenüberliegenden Elementen (64b, 64c) in jeder dieser Öffnungen (66) auf einem Kollisionsweg liegen, um mit diesen im Lauf der Bewegung des Plattengliedes in die erste Stellung in Anlage zu treten.

5. Ein elektrischer Verbinder gemäß Anspruch 3, wobei die Nockenflächen (94a, 96a) für jede dieser Öffnungen (66) im Lauf der Bewegung des Plattengliedes zwischen der ersten und der zweiten Stellung in den zweiten Anschlüssen angeordnet sind.

6. Ein elektrischer Verbinder gemäß Anspruch 1, weiter mit einem Nockenbetätigungsmittel, das in einer Richtung quer zu der gemeinsamen Richtung zwecks Verschieben des Nockenmittels zwischen der ersten und der zweiten Stellung verschiebbar ist.

7. Ein elektrischer Verbinder gemäß Anspruch 6, wobei das Nockenmittel und das Nockenbetätigungsmittel miteinander zusammenwirkende benachbarte Nockenflächen zum Bewirken der Verschiebung des Nockenmittels aufweisen, und wobei die Nockenflächen des Nockenmittels und das Nockenbetätigungsmittel sämtlich ein Vielzahl von sich gegenüberliegenden miteinander zusammenwirkenden geeigneten Nockenrampen und -schlitzen aufweisen, die aufeinander folgend auf jeder Nockenfläche im Abstand von einander liegen.

8. Ein elektrischer Verbinder gemäß Anspruch 7, wobei das Nockenmittel ein über dem Nockenbetätigungsmittel liegendes Plattenglied ist und eine Unterseite mit den geneigten Nockenrampen und -schlitzen aufweist, das Gehäuse das Plattenglied zwecks Bewegung in der gemeinsamen Richtung abstützt, und wobei das Nockenbetätigungsmittel ein unter dem Plattenglied liegendes Plattenelement ist und eine Oberseite mit den geneigten Nockenrampen und -schlitzen aufweist, das Gehäuse das Plattenelement zwecks Gleitbewegung in einer Querrichtung abstützt; die geneigten Nockenrampen des Plattengliedes und Plattenelementes in ebenen Flächen auslaufen, die ebenen Flächen von miteinander zusammenwirkenden Nockenrampen miteinander in Kontakt liegen, wenn sich das Plattenglied in der ersten Stellung befindet und die ebenen Flächen in sich gegenüberliegenden Schlitzen angeordnet sind, wenn sich das Plattenglied in der zweiten Stellung befindet.

Revendications

1. Un connecteur électrique pour interconnecter un ensemble de broches à bornes (62) selon un réseau prédéterminé à un appareil compagnon (12), comprenant:

(a) un boîtier;

(b) un ensemble de contacts (64) supportés par ledit boîtier selon ledit réseau et s'étendant dans une direction commune, chacun desdits contacts (64) comprenant une première borne (64a) en vue de la connexion avec ledit appareil compagnon (12) et une seconde borne adaptée à recevoir une telle broche à bornes (62) et comprenant des éléments en regard (64b, 64c) qui sont à autocontrainte pour revenir à une attitude présélectionnée, et

(c) un moyen à cames (28) comprenant des surfaces de cames (94a, 96a) et supporté de façon mobile dans ledit boîtier dans ladite direction commune, ledit moyen à cames (28) définissant un ensemble d'ouvertures (66) dans lesquelles lesdites secondes bornes sont reçues, ledit moyen à cames (28) étant mobile entre une première position dans laquelle lesdites surfaces de cames (94a, 96a) viennent en engagement avec lesdits éléments en regard (64b, 64c) de toutes lesdites secondes bornes pour s'opposer à leur autocontrainte et déplacer lesdits éléments en regard (64b, 64c) de ladite attitude présélectionnée, et une seconde position dans laquelle lesdites surfaces de cames (94a, 96a) ne s'opposent pas à l'autocontrainte de ladite seconde borne,

caractérisé en ce que lesdites surfaces de cames (94a, 96a) font saillie dans lesdites ouvertures (66) situées entre lesdits éléments en regard (64b, 64c) de manière que lorsque ledit moyen à cames (28) est déplacé dans sa première position, lesdites surfaces de cames (94a, 96a) s'engagent dans des parties internes (64f 1—4) desdits éléments en regard (64b, 64c) et amènent de ce fait lesdits éléments en regard (64b, 64c) à diverger

pour permettre auxdites broches (62) d'être facilement reçues dans lesdites secondes bornes; lesdits éléments en regard (64b, 64c) convergent lorsque ledit moyen à came (28) se déplace dans sa seconde position, ce grâce à quoi lesdits éléments en regard (64b, 64c) peuvent exercer entre eux la totalité de la force de ladite autocontrainte sur les broches (62).

2. Un connecteur électrique selon la revendication 1, caractérisé en ce que chacune desdites ouvertures (66) entoure totalement les contacts individuels (64) et en ce que les surfaces de cames (94a, 96a) sont collectivement mobiles.

3. Un connecteur électrique selon la revendication 1, caractérisé en ce que ledit moyen à cames (28) comprend un organe en forme de plaque (28) définissant ledit ensemble d'ouvertures (66) qui le traversent, les ouvertures (66) étant chacune en alignement avec lesdites secondes bornes lorsqu'elles reçoivent à l'intérieur lesdites secondes bornes, ledit boîtier supportant ledit organe en forme de plaque de façon qu'il puisse se déplacer dans ladite direction commune.

4. Un connecteur électrique selon la revendication 3, caractérisé en ce que ledit organe en forme de plaque définit lesdites surfaces de cames (94a, 96a), lesdites surfaces de cames (94a, 96a) entourant chacune partiellement ladite ouverture (66) et interférant avec le parcours des éléments en regard (64b, 64c) dans chacune desdites ouvertures (66) pour venir en engagement avec eux au cours du mouvement dudit organe en forme de plaque vers ladite première position.

5. Un connecteur électrique selon la revendication 3, caractérisé en ce que lesdites surfaces de cames (94a, 96a) de chacune desdites ouvertures (66) sont respectivement maintenues dans lesdites secondes bornes pendant toute la course de mouvement dudit organe en forme de plaque entre lesdites première et seconde positions.

6. Un connecteur électrique selon la revendication 1, comprenant en outre un moyen d'actionnement de cames mobile dans une direction transversale à ladite direction commune pour déplacer ledit moyen à cames entre ladite première position et ladite seconde position.

7. Un connecteur électrique selon la revendication 6 caractérisé en ce que ledit moyen à cames et ledit moyen d'actionnement de cames comprennent des surfaces de cames adjacentes et coopérantes pour réaliser le mouvement dudit moyen à cames, et en ce que lesdites surfaces de cames dudit moyen à cames et dudit moyen d'actionnement de cames comprennent chacune un ensemble de rampes et de fentes de cames inclinées, opposées et coopérantes, espacées successivement sur chaque surface de came.

8. Un connecteur électrique selon la revendication 7, caractérisé en ce que ledit moyen à cames comprend un organe en forme de plaque disposé au-dessus dudit moyen d'actionnement de cames, et possédant une surface inférieure comprenant lesdites rampes et fentes de cames inclinées, ledit boîtier supportant ledit organe en

forme de plaque de manière qu'il se déplace dans ladite direction commune, et en ce que ledit moyen d'actionnement de cames comprend un élément en forme de plaque disposé au-dessous dudit organe en forme de plaque et possédant une surface supérieure comprenant lesdites rampes et fentes de cames inclinées, ledit boîtier supportant ledit élément en forme de plaque de façon qu'il puisse effectuer un mouvement glissant transversal; les rampes de cames inclinées

5

10

dudit organe en forme de plaque et l'élément en forme de plaque se terminant respectivement par des surfaces plates, lesdites surfaces plates desdites rampes de cames coopérantes étant en contact quand ledit organe en forme de plaque est dans ladite première position et lesdites surfaces plates étant disposées dans des fentes opposées quand ledit organe en forme de plaque est dans ladite seconde position.

15

20

25

30

35

40

45

50

55

60

65

8

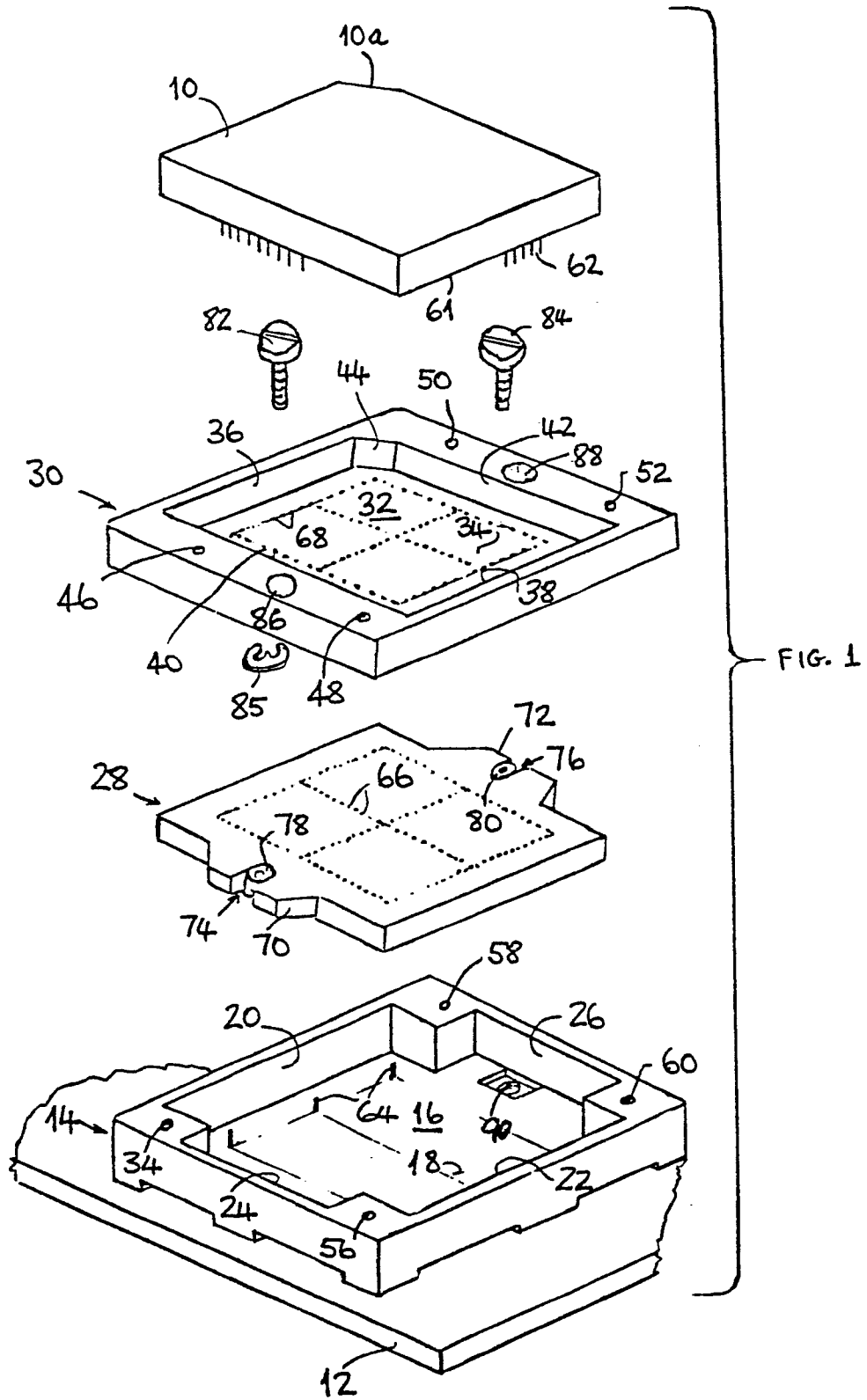

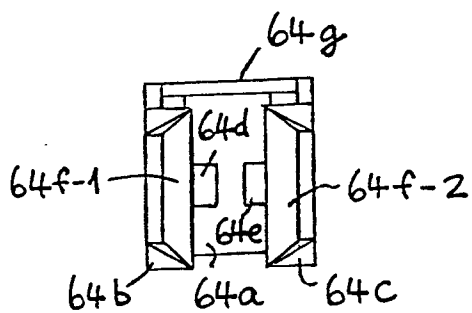

FIG. 5

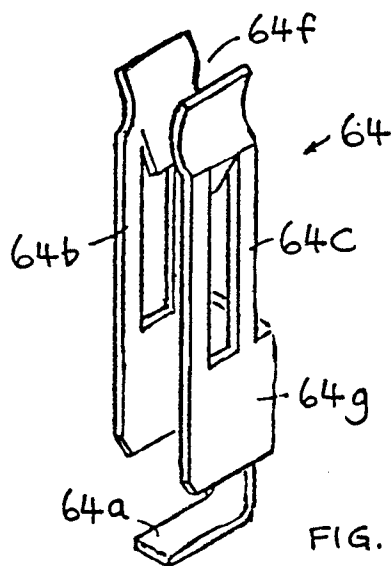

FIG. 2

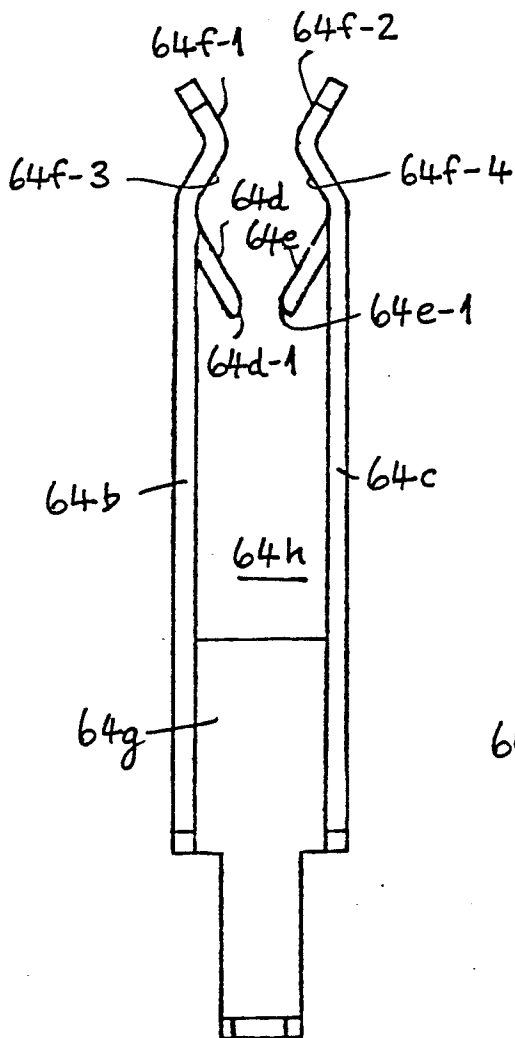

FIG. 3

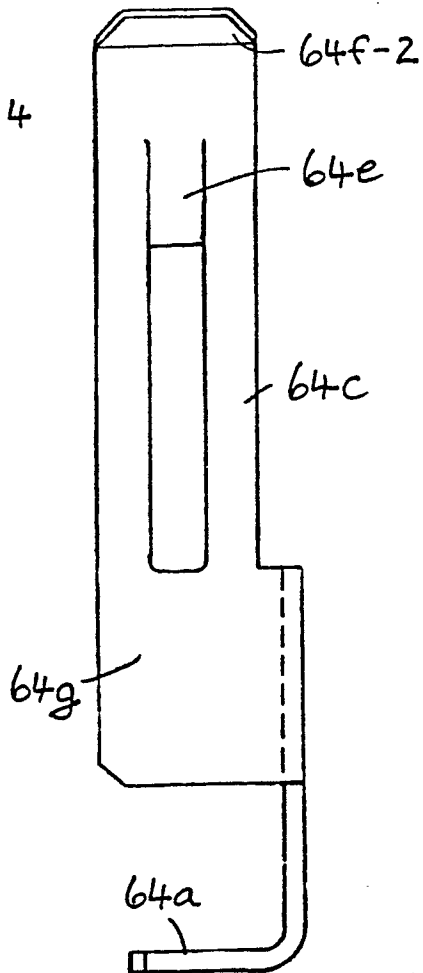

FIG. 4.

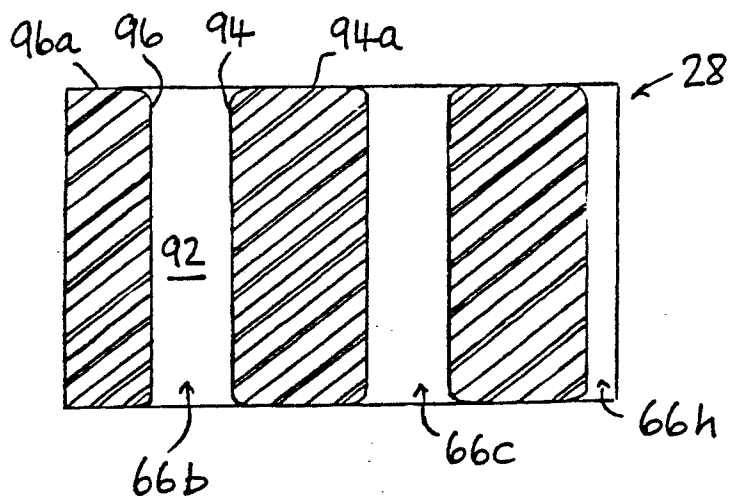
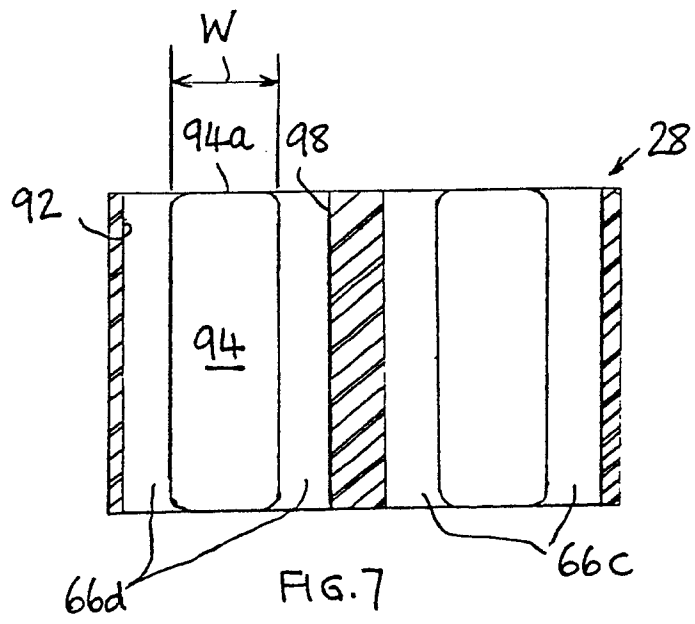

FIG. 8

