

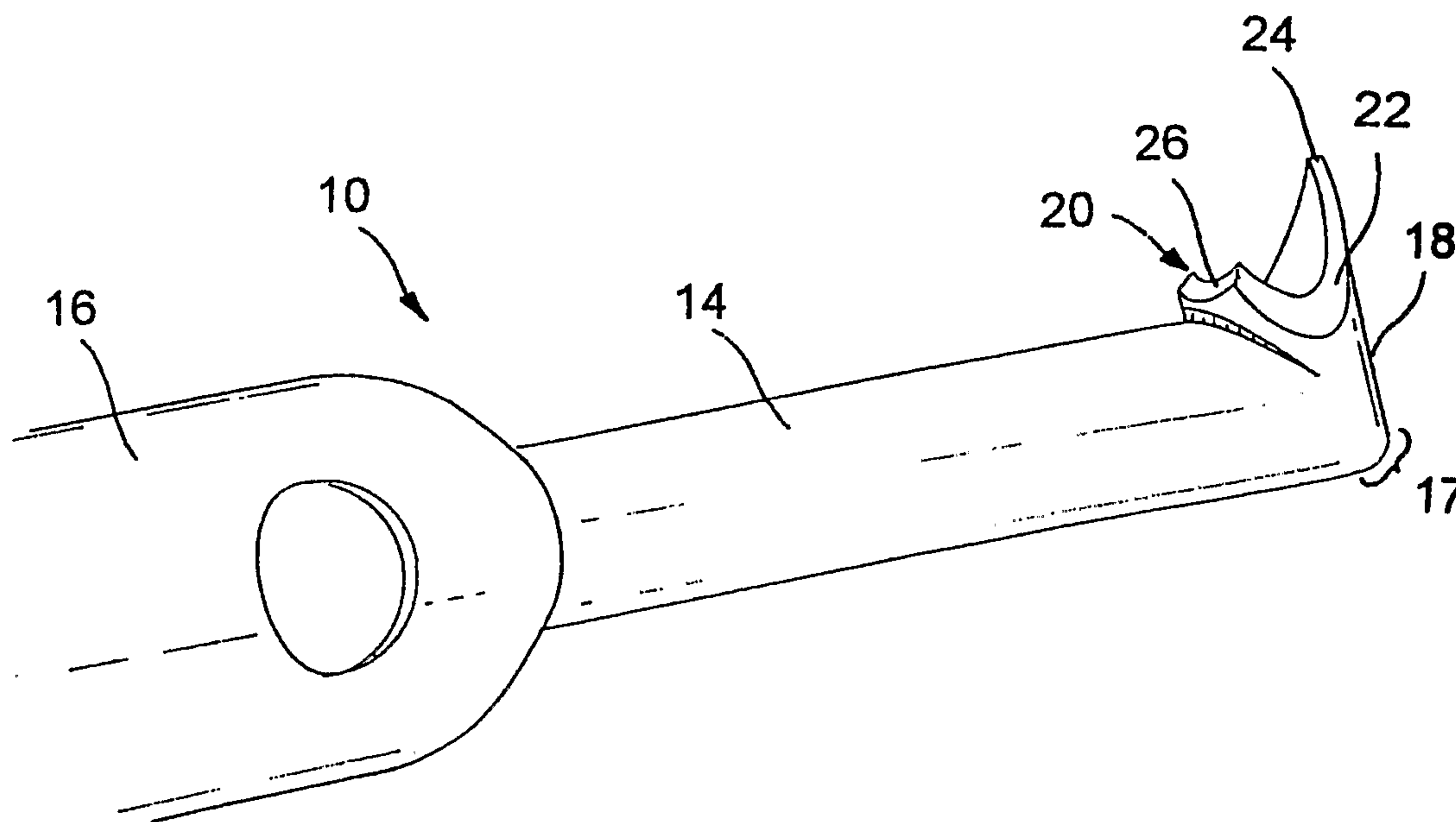

(86) Date de dépôt PCT/PCT Filing Date: 2004/06/10
 (87) Date publication PCT/PCT Publication Date: 2004/12/23
 (85) Entrée phase nationale/National Entry: 2005/12/02
 (86) N° demande PCT/PCT Application No.: US 2004/018488
 (87) N° publication PCT/PCT Publication No.: 2004/110501
 (30) Priorité/Priority: 2003/06/10 (60/477,258) US

(51) Cl.Int./Int.Cl. *A61B 17/32* (2006.01)
 (71) Demandeur/Applicant:
NEOMEDIX CORPORATION, US
 (72) Inventeurs/Inventors:
SORENSEN, JOHN T., US;
MITTELSTEIN, MICHAEL, US;
MIRHASHEMI, SOHEILA, US
 (74) Agent: GOWLING LAFLEUR HENDERSON LLP

(54) Titre : CUTTER TUBULAIRE ET PROCEDES DE COUPE ET D'ELIMINATION DE BANDES D'UN TISSU DU
CORPS D'UN PATIENT
 (54) Title: TUBULAR CUTTING DEVICE FOR CUTTING AND REMOVING TISSUE



(57) **Abrégé/Abstract:**

Methods and devices for cutting strips of tissue from masses of tissue inside or outside of the bodies of human or animal subjects. The device generally comprises a) an elongate cutting tube that has a distal end and a lumen that opens through an opening in the distal end and b) first and second cutting edges formed on generally opposite edges of the distal end of the cutting tube and separated by a distance D. The device is advanced through tissue to cut a strip of tissue of approximate width W. Width W is approximately equal to distance D.

(12) INTERNATIONAL APPLICATION PUBLISHED UNDER THE PATENT COOPERATION TREATY (PCT)

(19) World Intellectual Property
Organization
International Bureau



(43) International Publication Date
23 December 2004 (23.12.2004)

PCT

(10) International Publication Number
WO 2004/110501 A3

- (51) International Patent Classification⁷: **A61B 17/32**
- (21) International Application Number:
PCT/US2004/018488
- (22) International Filing Date: 10 June 2004 (10.06.2004)
- (25) Filing Language: English
- (26) Publication Language: English
- (30) Priority Data:
60/477,258 10 June 2003 (10.06.2003) US
- (71) Applicant (for all designated States except US):
NEOMEDIX CORPORATION [US/US]; 27452 Calle Arroyo, San Juan Capistrano, CA 92675 (US).
- (72) Inventors; and
- (75) Inventors/Applicants (for US only): **SORENSEN, John, T.** [US/US]; 19 Barnstable Way, Ladera Ranch, CA 92694 (US). **MITTELSTEIN, Michael** [DE/US]; 29412 Clipper Way, Laguna Niguel, CA 92677 (US). **MIRHASHEMI, Soheila** [US/US]; 29412 Clipper Way, Laguna Niguel, CA 92677 (US).
- (74) Agent: **BUYAN, Robert, D.**; Stout, Uxa, Buyan & Mullins, LLP., 4 Venture, Suite 300, Irvine, CA 92618 (US).
- (81) Designated States (unless otherwise indicated, for every kind of national protection available): AE, AG, AL, AM, AT, AU, AZ, BA, BB, BG, BR, BW, BY, BZ, CA, CH, CN, CO, CR, CU, CZ, DE, DK, DM, DZ, EC, EE, EG, ES, FI, GB, GD, GE, GH, GM, HR, HU, ID, IL, IN, IS, JP, KE, KG, KP, KR, KZ, LC, LK, LR, LS, LT, LU, LV, MA, MD, MG, MK, MN, MW, MX, MZ, NA, NI, NO, NZ, OM, PG, PH, PL, PT, RO, RU, SC, SD, SE, SG, SK, SL, SY, TJ, TM, TN, TR, TT, TZ, UA, UG, US, UZ, VC, VN, YU, ZA, ZM, ZW.
- (84) Designated States (unless otherwise indicated, for every kind of regional protection available): ARIPO (BW, GH, GM, KE, LS, MW, MZ, NA, SD, SL, SZ, TZ, UG, ZM, ZW), Eurasian (AM, AZ, BY, KG, KZ, MD, RU, TJ, TM), European (AT, BE, BG, CH, CY, CZ, DE, DK, EE, ES, FI, FR, GB, GR, HU, IE, IT, LU, MC, NL, PL, PT, RO, SE, SI, SK, TR), OAPI (BF, BJ, CF, CG, CI, CM, GA, GN, GQ, GW, ML, MR, NE, SN, TD, TG).
- Published:
— with international search report
- (88) Date of publication of the international search report:
29 December 2005

[Continued on next page]

(54) Title: TUBULAR CUTTING DEVICE FOR CUTTING AND REMOVING TISSUE

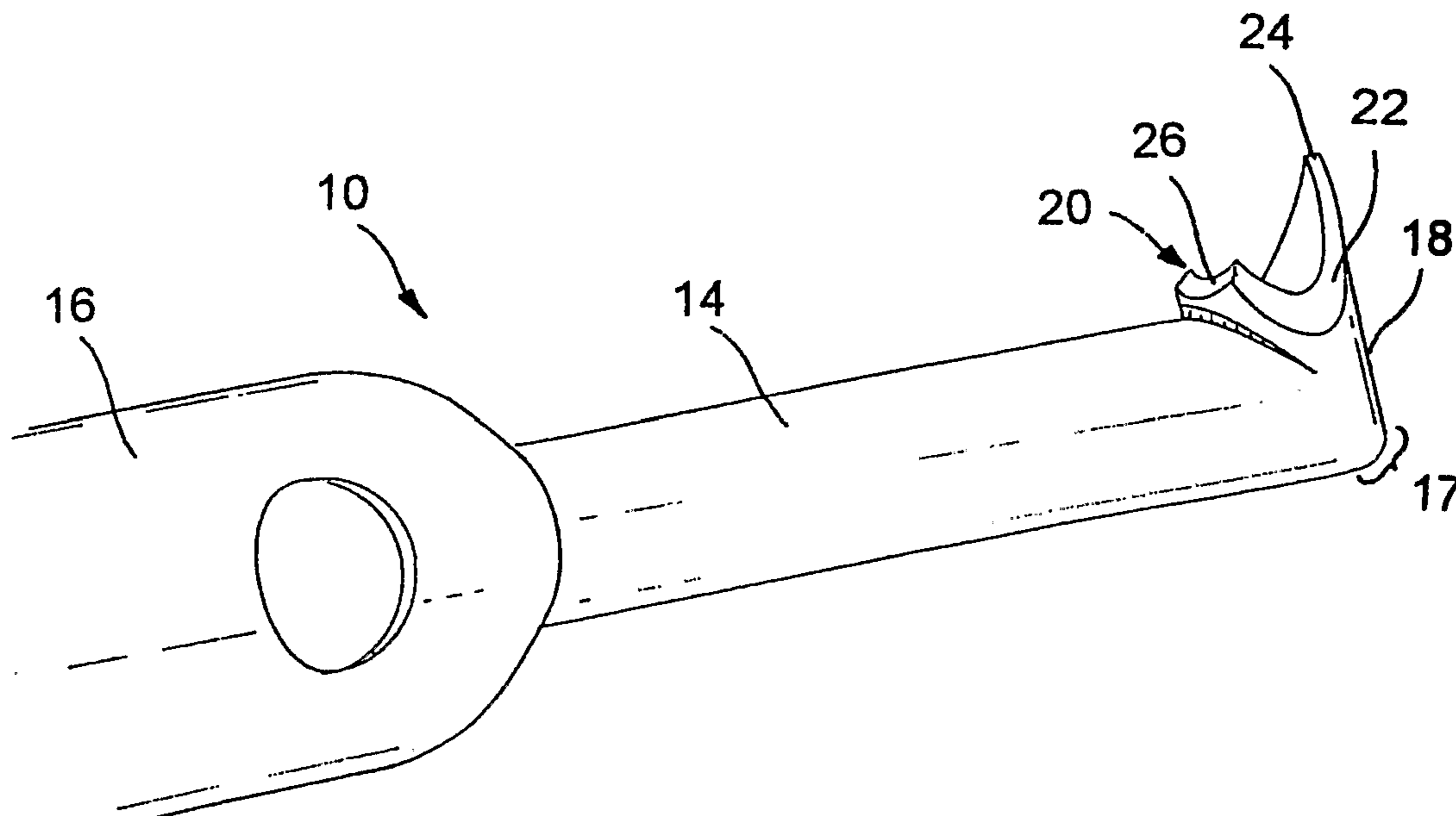

(57) Abstract: Methods and devices for cutting strips of tissue from masses of tissue inside or outside of the bodies of human or animal subjects. The device generally comprises a) an elongate cutting tube that has a distal end and a lumen that opens through an opening in the distal end and b) first and second cutting edges formed on generally opposite edges of the distal end of the cutting tube and separated by a distance D. The device is advanced through tissue to cut a strip of tissue of approximate width W. Width W is approximately equal to distance D.

WO 2004/110501 A3

WO 2004/110501 A3



For two-letter codes and other abbreviations, refer to the "Guidance Notes on Codes and Abbreviations" appearing at the beginning of each regular issue of the PCT Gazette.

TUBULAR CUTTER DEVICE AND METHODS FOR CUTTING AND REMOVING STRIPS OF TISSUE FROM THE BODY OF A PATIENT

5 **RELATED APPLICATIONS**

This application claims priority to United States Provisional Patent Application No. 60/477,258 filed on June 10, 2003, the entirety of which is expressly incorporated herein by reference.

10 **BACKGROUND OF THE INVENTION**

There are numerous medical and surgical procedures in which it is desirable to cut and remove a strip of tissue of controlled width from the body of a human or veterinary patient. For example, it may sometimes be desirable to form an incision of a controlled width (e.g., an incision that is wider than an
15 incision made by a typical scalpel or cutting blade) in the skin, mucous membrane, tumor, organ or other tissue or a human or animal. Also, it may sometimes desirable to remove a strip or quantity of tissue from the body of a human or animal for use as a biopsy specimen, for chemical/biological analysis, for retention or archival of DNA identification purposes, etc. Also,
20 some surgical procedures require removal of a strip of tissue of a known width from an anatomical location within the body of a patient.

One surgical procedure wherein a strip of tissue of a known width is removed from an anatomical location within the body of a patient is an ophthalmological procedure used to treat glaucoma. This ophthalmological
25 procedure is sometimes referred to as a goniotomy. In a goniotomy procedure, a device that is operative to cut or ablate a strip of tissue of approximately 2-10 mm in length and about 50-200 μm in width is inserted into the anterior chamber of the eye and used to remove a full thickness strip of tissue from the trabecular meshwork. The trabecular meshwork is a loosely
30 organized, porous network of tissue that overlies a collecting canal known as Schlemm's canal. A fluid, known as aqueous humor, is continually produced in the anterior chamber of the eye. In normal individuals, aqueous humor flows through the trabecular meshwork, into Shlemm's Canal and out of the

eye through a series of ducts. In patients who suffer from glaucoma, the drainage of aqueous humor from the eye may be impaired by elevated flow resistance through the trabecular meshwork, thereby resulting in an increase in intraocular pressure. The goniotomy procedure can restore normal drainage of aqueous humor from the eye by removing a full thickness segment of the trabecular meshwork, thus allowing the aqueous humor to drain through the open area from which the strip of trabecular meshwork has been removed. The goniotomy procedure and certain prior art instruments useable to perform such procedure are described in United States Patent Application Serial No. 10/052,473 published as No. 2002/011608A1 (Baerveldt), the entirety of which is expressly incorporated herein by reference.

At present there remains a need in the art for the development of simple, inexpensive and accurate instruments useable to perform the goniotomy procedure as well as other procedures where it is desired to remove a strip of tissue from a larger mass of tissue.

SUMMARY OF THE INVENTION

The present invention provides a device for cutting a strip of tissue of approximate width W from a mass of tissue. The device generally comprises a) an elongate cutting tube that has a distal end and a lumen that opens through an opening in the distal end and b) first and second cutting edges formed on generally opposite edges of the distal end of the cutting tube and separated by a distance D . The cutting tube is advanceable through tissue such that the first and second cutting edges will cut a strip of tissue having approximate width W , wherein the approximate width W is approximately equal to the distance D between the first and second cutting edges. In some embodiments, the strip of tissue may be aspirated or otherwise removed through the lumen of the cutter tube. In some embodiments, the device may include apparatus useable to sever (e.g., transversely cut or transect) the strip of tissue when the strip of tissue has reached a desired length.

Further in accordance with the invention there is provided a method for cutting a strip of tissue of width W from a tissue mass. This method generally

comprises the steps of a) providing a device that comprises i) an elongate cutting tube that has a distal end and a lumen that opens through an opening in the distal end and ii) first and second cutting edges formed on generally opposite edges of the distal end of the cutting tube and separated by a distance D that is approximately equal to the width W of the strip of tissue to be cut; and b) advancing the distal end of the cutting tube through the mass of tissue such that the first and second cutting edges cut a strip of tissue of approximate width W. Further aspects and elements of the invention will be understood by those of skill in the art upon reading the detailed description of specific examples set forth herebelow.

BRIEF DESCRIPTION OF THE DRAWINGS

Figure 1 is a perspective view of a system incorporating a needle cutting device of the present invention.

Figure 2 is an enlarged perspective view of section 2 of Figure 1.

Figures 3A-3D show various steps in a method for manufacturing a needle cutter of the present invention.

Figure 4 is a side view of a distal portion of a needle cutter device of the present invention being used to cut a strip of tissue of approximate width W.

Figure 5 is a perspective view of the distal portion of a needle cutter device of the present invention incorporating apparatus for severing a strip of tissue cut by the needle cutter device after the strip of tissue has reached a desired length.

Figure 6 is a side view of the distal portion of another embodiment of a needle cutter device of the present invention having a plurality of curves or bends formed in the cutting tube.

DETAILED DESCRIPTION

The following detailed description, and the drawings to which it refers, are provided for the purpose of describing and illustrating certain preferred embodiments or examples of the invention only, and no attempt has been made to exhaustively describe all possible embodiments or examples of the

invention. Thus, the following detailed description and the accompanying drawings shall not be construed to limit, in any way, the scope of the claims recited in this patent application and any patent(s) issuing therefrom.

One example of a needle cutter device 10 of the present invention is shown in Figures 1-4. This needle cutter device 10 generally comprises an elongate cutting tube 14 that has a distal end and a lumen 27 that opens through an opening in the distal end. First and second cutting edges 20, 22 are formed on generally opposite edges of the distal end of the cutting tube 14. These first and second cutting edges 20, 22 are separated by a distance D, as shown in the distal end view of Figure 3B. In the particular example shown in the drawings, the first and second cutting edges 20, 22 are located on opposite lateral sides of the distal end of the cutting tube 14 and a blunt, protruding tip 24 is located on the bottom of the distal end of the cutting tube. Also, a blunt edge 26 is located at the top of the distal end of the cutting tube 14. Thus, only the lateral cutting edges 20, 22 are sharp and intended to cut tissue. The blunt, protruding tip 24 can, in some applications, be configured and used to facilitate insertion of the device 10 to its intended location and/or the blunt protruding tip 24 may be placed in an anatomical or man made groove or channel (e.g., Schlemm's Canal of the eye) such that it will then advance through the channel or groove and guide the advancement and positioning of the remainder of the device 10.

One or more bends or curves may optionally be formed in the cutting tube 14 to facilitate its use for its intended purpose. For example, in the embodiment of the device 10 shown in Figure 2, a single bend 17 of approximately 90 degrees is formed near the distal end of the cutting tube 14. In the embodiment of the device 10b shown in Figure 6, two separate bends of approximately 90 degrees each are formed at spaced apart locations on the cutting tube 14, thereby giving the cutting tube 14 a generally U shaped configuration. It will be appreciated that any number of bends or curves, in any direction and of any severity may be formed in the cutting tube 14 to facilitate its use in specific procedures or to enable it to be inserted through tortuous anatomical channels of the body. In most cases, the degree of curvature in embodiments where a single bend or curve is formed will be

between approximately 30 and approximately 90 degrees and in embodiments where more than one bend or curve are formed in the cutting tube 14 each such bend or curve will typically be between approximately 15 to approximately 90 degrees.

5 As shown in Figure 4, when the cutting tube 14 is advanced through tissue, distal end first, the first and second cutting edges 20, 22 will cut a strip ST of tissue having approximate width W, such approximate width W being approximately equal to the distance D between the first and second cutting edges 20, 22. The severed strip ST of tissue will enter the lumen 27 of the
10 cutting tube 14 as the device advances. Negative pressure may be applied to lumen 27 to aspirate the strip ST of tissue and/or fluid and/or other matter through lumen 27.

The device 10 may optionally include a second lumen. Such second lumen may be used for infusion of fluid through the device 10 or for other
15 purposes. In the embodiment shown in Figures 1 and 2, the device 10 comprises an outer tube 16 in addition to the cutting tube 14. The cutting tube 14 is of smaller diameter than the outer tube 16 and the cutting tube 14 may extend through the lumen 19 of the outer tube 16 such that a distal portion of the cutting tube 14 extends out of and beyond the distal end of the outer tube
20 16, as may be seen in Figure 2. The distal end of the outer tube 16 is tapered and in close approximation with the outer surface of the cutting tube 14. Fluid may be infused through the lumen 19 of the outer tube 16, through the space between the outer surface of the cutting tube 14 and the inner surface of the outer tube 16. Fluid that is infused through the lumen 19 of the outer tube 16
25 may flow out of one or more apertures 11 formed near the distal end of the outer tube.

In some embodiments, the device 10 may be equipped with severing apparatus for severing (e.g., transversely cutting or transecting) the strip ST of tissue to fully excise or detach the strip ST of tissue from the remaining tissue
30 mass and/or from the body of a human or animal subject. Such severing apparatus may comprise any suitable type of tissue cutter such as a blade, scissor, guillotine, electrode(s), laser, energy emitting tissue cutter, mechanical tissue cutter, etc. Figure 5 shows an example of an embodiment

of the device 10a wherein monopolar or bipolar electrode(s) 40 are located on the distal end of the cutting tube 14. When it is desired to sever the strip ST of tissue, the electrode(s) is/are energized with sufficient energy to sever the strip ST, thereby disconnecting the strip ST from the remaining tissue mass and/or the body of the human or animal subject.

In some embodiments of the device 10, the cutting edges 20, 22 may be heated such that they will cauterize as the cut. As those of skill in the art will appreciate, such heating of the cutting edges 20, 22 may be accomplished by placement of electrode(s) near the cutting edges 20, 22 such that, when the electrode(s) is/are energized, the cutting edges 20, 22 will become heated to a temperature suitable for the desired cauterization function.

The needle cutter device 10 of the present invention may optionally be used as part of a system 12, as shown in Figure 1. The basic components of the system 12 comprise an aspiration pump module 74 and a source of irrigation fluid 72, mounted on a surgical roller cart 70. Control of the console functions during procedures may be accomplished by an aspiration foot pedal 78 which controls an aspiration pump 74 and variation in the height of the source of infusion fluid 72 to change the gravity fed pressure or flow rate of infusion fluid through the device. A pinch valve, or other means, may also be incorporated in the console to control flow of the irrigation fluid to the needle cutter device 10. In embodiments that include apparatus (e.g., electrode(s)) for heating the cutting edges 20, 22 and/or for severing the strip ST of tissue (Figure 5), the system 11 may additionally comprise an electrical current source, such as an electrosurgical generator 76 and electrosurgical foot pedal 80 which controls the electrosurgical generator to deliver desired amount(s) of energy to the electrode(s) or other electrical elements (e.g., resistance heater(s), etc.) on the device 10. As an option, all of the basic control functions of system 12 may be integrated into a single footpedal to facilitate use.

The device 10 may be provided as a pre-sterilized, single-use disposable probe or tip that is attachable to a standard surgical irrigation/aspiration handpiece such as that commercially available as The Rhein I/A Tip System from Rhein Medical, Inc., Tampa, Florida. After the

device 10 has been attached to the handpiece, it may be connected to any or all of the electrosurgical generator module 76, aspiration pump module 74 and the source of irrigation fluid 72, as shown. Thus, the device 10 may be fully equipped for irrigation, aspiration, and electrosurgical capabilities, as described herein.

Figures 3A-3D show an example of a method for manufacturing the cutting tube 14 from standard tubing (e.g., stainless steel hypodermic tubing). Initially, the distal end of a tube is cut to form the lateral cutting edges 20, 22, the protruding tip 24 and the blunt top edge 26. Thereafter, if it is desired to have one or more bends or curves in the cutting tube 14, angular cut out(s) 30 may be formed in the tube 14, as shown in Figure 3C. Thereafter, the tube 14 is bent to bring the edges of each angular cut out 30 into apposition and weld, adhesive or other joining techniques are used to weld or join the apposed edges of the cut outs together, thereby forming the desired bend(s) or curve(s) in the cutting tube 14. Likewise, if it is desired to have one or more bends or curves in the cutting tube 14, the tube 14 may be directly bent to form said curves or bends without the use of angular cut outs(s) 30. It may be appreciated that the use of angular cut-out(s) 30 allow a tube 10 of a given diameter to incorporate a curve or angle in a more compact form than is possible by bending tubing 10 of a given diameter to said curve or angle without kinking or damaging tube 10.

The device 10 and system 12 are useable to perform a variety of procedures wherein it is desired to form an incision or opening of a desired width or to remove, from a mass of tissue, a strip ST of tissue of a desired width.

One particular procedure that may be performed to treat glaucoma, using the device 10 and system 12 of the present invention, is a goniotomy. As explained herein a goniotomy procedure is an *ab interno* surgical procedure wherein a sector of the trabecular meshwork is removed from the eye of the patient to facilitate drainage of aqueous humor from the anterior chamber of the eye through Schlemm's Canal and the associated collector channels, thereby relieving elevated intraocular pressure.

To perform a goniotomy procedure using the device 10, first a small incision is made in the cornea at about 3 o'clock in the left eye, or at about 9 o'clock in the right eye. A 1.5 mm slit knife may be used to make this incision .

The device 10 is attached to the source of irrigation fluid 72 (e.g., basic
5 balanced salt solution) such that irrigation fluid will flow through lumen 19 of the
outer tube 16 and out of outflow aperture 11. The device 10 is then inserted
through the incision and into the anterior chamber of the eye (with irrigation
flowing). In some cases, during the insertion of the device 10, the source of
irrigation fluid 72 may initially connected to the device such that the irrigation
10 fluid will flow through the lumen 27 of the cutter tube 14. In this manner,
irrigation fluid will begin to infuse into the anterior chamber of the eye as soon
as the distal end of the cutter tube 14 has entered the anterior chamber, rather
than being delayed until the larger outer tube 16 and aperture 11 have been
advanced through the incision and into the anterior chamber. By this
15 alternative approach, irrigation fluid may be caused to flow out of the distal end
of the cutter tube 14 as the device 10 is being inserted, thereby spreading or
opening the incision by hydraulic force while in addition increasing the fluid
pressure in the anterior chamber. Such spreading or opening of the incision
may facilitate advancement of the larger diameter outer tube 16 through the
20 incision. Pressurizing the fluid in the anterior chamber causes the anterior
chamber to deepen and may facilitate maneuvering of device 10 within the
anterior chamber. In cases where this alternative approach is used, the source
of infusion fluid 72 may be disconnected from lumen 27 of the cutter tube 14
after the device 10 has been inserted into the anterior chamber and, thereafter,
25 the infusion fluid source 72 may be reconnected to lumen 19 of outer tube 16
such that infusion fluid will flow out of aperture 11. Negative pressure (e.g., via
aspiration pump module 74) may then be applied to lumen 27 of the cutter tube
14 so as to aspirate fluid and debris through lumen 27 as shown in Figure 4.
The vertical height of the infusion fluid source 72 may be adjusted to provide
30 sufficient gravity feed of infusion fluid to make up for the volume of fluid or
matter being aspirated from the anterior chamber through lumen 27, thereby
maintaining the desired pressure of fluid within the anterior chamber during the
procedure.

A lens device (e.g., Ocular Swan-Jacob Autoclavable Gonioprism, Model OSJAG, Ocular Instruments Inc., Bellevue, Washington) may be positioned on the anterior aspect of the eye to enable the physician to clearly visualize the angle of the eye where the segment of trabecular meshwork is to be removed.

5 Under direct visualization, the device 10 is advanced until the distal tip of the cutter tube 14 is positioned adjacent to the trabecular meshwork at the location where the strip ST is to be removed. Thereafter, the protruding tip 24 is advanced through the trabecular meshwork and into Schlemm's Canal.

10 The device 10 is then advanced along Schlemm's Canal, thereby causing the cutting edges 20, 22 to cut a strip of the trabecular meshwork, thereby creating an opening through which aqueous humor may drain from the anterior chamber of the eye.

15 After a strip of tissue of the desired length (e.g., about 2-10 mm) has been cut by the lateral cutting edges 20, 22, any optional tissue severing apparatus (e.g., electrode(s) 40 may be used (if present) to transect or sever the strip ST of tissue thereby disconnecting it from the patient's body and allowing it to be aspirated or drawn into or through lumen 27.

Thereafter, the aspiration is stopped, the device 10 is removed from the eye, and the infusion is stopped.

20 Following completion of the surgery, aqueous humor will drain from the anterior chamber through the opening that was created by removal of the strip of tissue from the trabecular meshwork TM.

25 Although the invention has been described above with respect to certain embodiments and examples, it is to be appreciated that such embodiments and examples are non-limiting and are not purported to define all embodiments and examples of the invention. Indeed, those of skill in the art will recognize that various modifications may be made to the above-described embodiments and examples without departing from the intended spirit and scope of the invention and it is intended that all such modifications
30 be included within the scope of the following claims.

CLAIMS**What is claimed is:**

- 1 1. A device for cutting a strip of tissue of approximate width W from a
2 mass of tissue, said device comprising:
3 an elongate cutting tube having a distal end and a lumen that opens
4 through an opening in the distal end;
5 first and second cutting edges being formed on generally opposite
6 edges of the distal end of the cutting tube said first and second cutting edges
7 being separated by a distance D ;
8 said cutting tube being advanceable through tissue such that the first
9 and second cutting edges will cut a strip of tissue having approximate width
10 W , said approximate width W being approximately equal to the distance D
11 between the first and second cutting edges.
- 1 2. A device according to Claim 1 wherein the cutting tube comprises a
2 stainless steel hypodermic tubing.
- 1 3. A device according to Claim 1 further comprising at least one
2 protruding tip formed on the distal end of the cutting tube.
- 1 4. A device according to Claim 2 wherein the protruding tip is tapered.
- 1 5. A device according to Claim 2 wherein the protruding tip is sufficiently
2 blunt to be substantially a traumatic.
- 1 6. A device according to Claim 1 wherein the first and second cutting
2 edges are located on opposite lateral sides of the distal end of the cutting
3 tube.

1 7. A device according to Claim 4 wherein the first and second cutting
2 edges are located on opposite lateral sides of the distal end of the cutting tube
3 and the protruding tip is located on the bottom of the distal end of the cutting
4 tube.

1 8. A device according to Claim 7 further comprising a blunt edge located
2 at the top of the distal end of the cutting tube.

1 9. A device according to Claim 1 wherein there is a single bend or curve
2 formed in the cutting tube.

1 10. A device according to Claim 9 wherein there is a single bend of
2 approximately 20 degrees to approximately 90 degrees formed in the cutting
3 tube.

1 11. A device according to Claim 10 wherein the bend is approximately 90
2 degrees.

1 12. A device according to Claim 1 wherein there are a plurality of bends or
2 curves formed in the cutting tube.

1 13. A device according to Claim 12 wherein there are a plurality of bends
2 of approximately 20 degrees to approximately 90 degrees each formed in the
3 cutting tube.

1 14. A device according to Claim 12 wherein there is a first bend of
2 approximately 90 degrees and a second bend of approximately 90 degrees,
3 formed in the tube.

1 15. A device according to Claim 1 further comprising a source of negative
2 pressure connected to the lumen of the cutting tube so as to aspirate fluid or
3 matter through the lumen of the tube.

1 16. A device according to Claim 1 wherein the device further comprises a
2 second lumen.

1 17. A device according to Claim 16 wherein one of the lumens is
2 connected to a source of fluid such that fluid may be infused therethrough and
3 the other of said lumens is connected to a source of negative pressure such
4 that fluid or matter may be aspirated therethrough.

1 18. A device according to Claim 1 wherein at least one of the cutting edges
2 is heated such that it will cauterize as it cuts.

1 19. A device according to Claim 1 further comprising apparatus for
2 severing the strip of tissue when the strip of tissue has reached a desired
3 length.

1 20. A device according to Claim 19 wherein the apparatus for severing the
2 strip of tissue comprises at least one electrode which, when energized, will
3 sever the strip of tissue.

1 21. A device according to Claim 1 wherein the device further comprises:
2 a second tube that has a lumen and a distal end;
3 wherein the cutting tube extends through the lumen of the outer tube
4 with a distal portion of the cutting tube extending out of and beyond the distal
5 end of the outer tube.

1 22. A device according to Claim 21 wherein:
2 the outer diameter of the cutting tube is smaller than the inner diameter
3 of the second tube such that fluid may flow through the lumen of the second
4 tube; and
5 at least one aperture is formed in the second tube to permit fluid to
6 pass into or out of the lumen of the second tube.

- 1 23. A method for cutting a strip of tissue of width W from a tissue mass,
2 said method comprising the steps of:
- 3 A) providing a device which comprises;
- 4 i. an elongate cutting tube that has a distal end and a lumen
5 that opens through an opening in the distal end; and
6 ii. first and second cutting edges formed on generally opposite
7 edges of the distal end of the cutting tube, said first and second cutting
8 edges being separated by a distance D that is approximately equal to
9 the width W of the strip of tissue to be cut; and
- 10 B) advancing the distal end of the cutting tube through the mass of
11 tissue such that the first and second cutting edges cut a strip of tissue
12 of approximate width W .
- 1 24. A method according to Claim 23 wherein the mass of tissue is *in vivo*.
- 1 25. A method according to Claim 23 wherein the mass of tissue is *in vitro*.
- 1 26. A method according to Claim 23 wherein the mass of tissue is located
2 within the body of a human or animal subject.
- 1 27. A method according to Claim 26 wherein the strip of tissue is removed
2 for a diagnostic or therapeutic purpose.
- 1 28. A method according to Claim 27 wherein the subject suffers from
2 glaucoma and wherein the method is carried out to remove a strip of
3 trabecular meshwork from an eye of the subject to facilitate drainage of
4 aqueous humor from the eye thereby lowering intraocular pressure.
- 1 29. A method according to Claim 28 wherein Step B comprises:
2 inserting the device into the anterior chamber of the eye;
3 positioning the distal end of the cutting tube adjacent to or within the
4 trabecular meshwork of the eye; and

5 advancing the cutting tube such that the cutting edges cut a strip of
6 approximate width W from the trabecular meshwork.

1 30. A method according to Claim 29 wherein the device provided in Step A
2 of the method further comprises a protruding tip and wherein the protruding tip
3 is advanced through the trabecular meshwork and into Schlemm's Canal and,
4 thereafter, the protruding tip is advanced through Schlemm's Canal as the
5 cutting tube is advanced to cut the strip of tissue.

1 31. A method according to Claim 23 wherein the device provided in Step A
2 further comprises apparatus for severing the strip of tissue after the strip of
3 tissue has reached a desired length and wherein the method further
4 comprises the step of:

5 C) severing the strip of tissue after the strip of tissue has reached a
6 desired length.

1 32. A method according to Claim 23 wherein the method is carried out to
2 form an incision in skin, mucous membrane, an organ, a tumor or other
3 anatomical structure.

1 33. A method according to Claim 23 further comprising the step of:

2 C) removing the strip of tissue through the lumen of the cutting
3 tube.

1 34. A method according to Claim 33 wherein the lumen of the cutting tube
2 is attached to a source of negative pressure to aspirate the strip of tissue
3 through the lumen of the cutting tube.

1 35. A method according to Claim 23 wherein the device provided in Step A
2 further comprises a second lumen and wherein the method further comprises:

3 infusing a fluid through one of said lumens; and
4 aspirating fluid and/or matter through the other of said lumens.

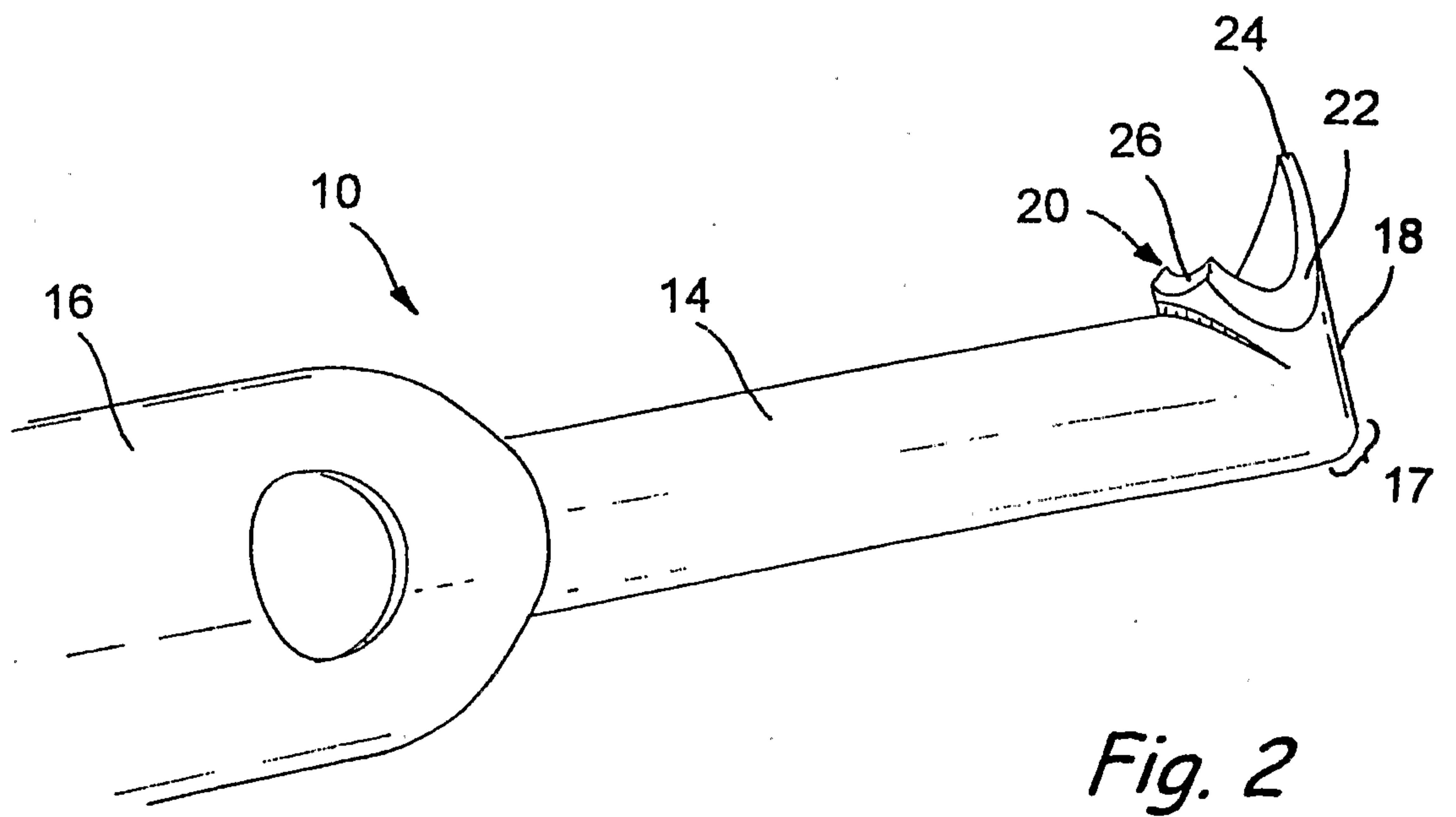
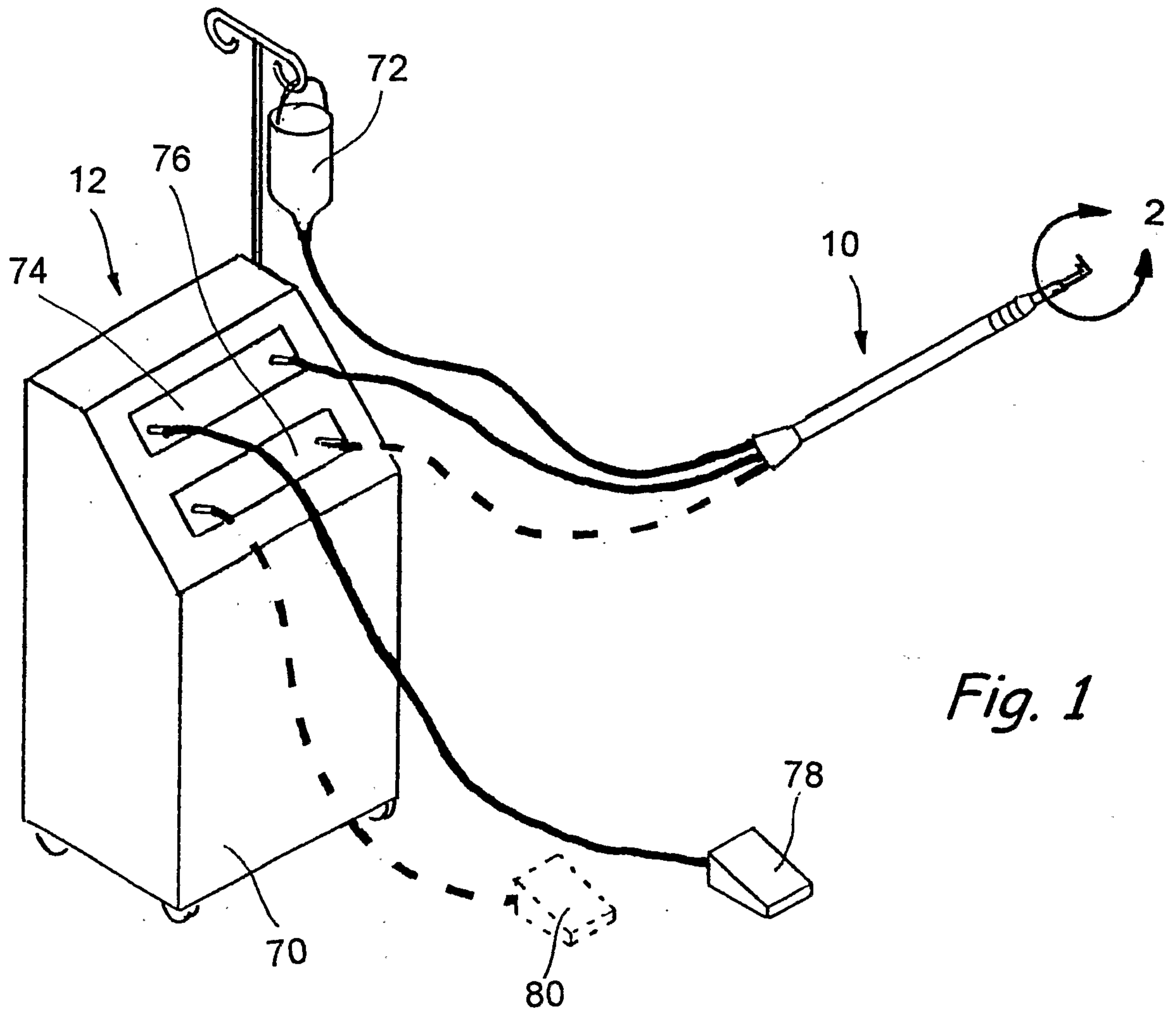

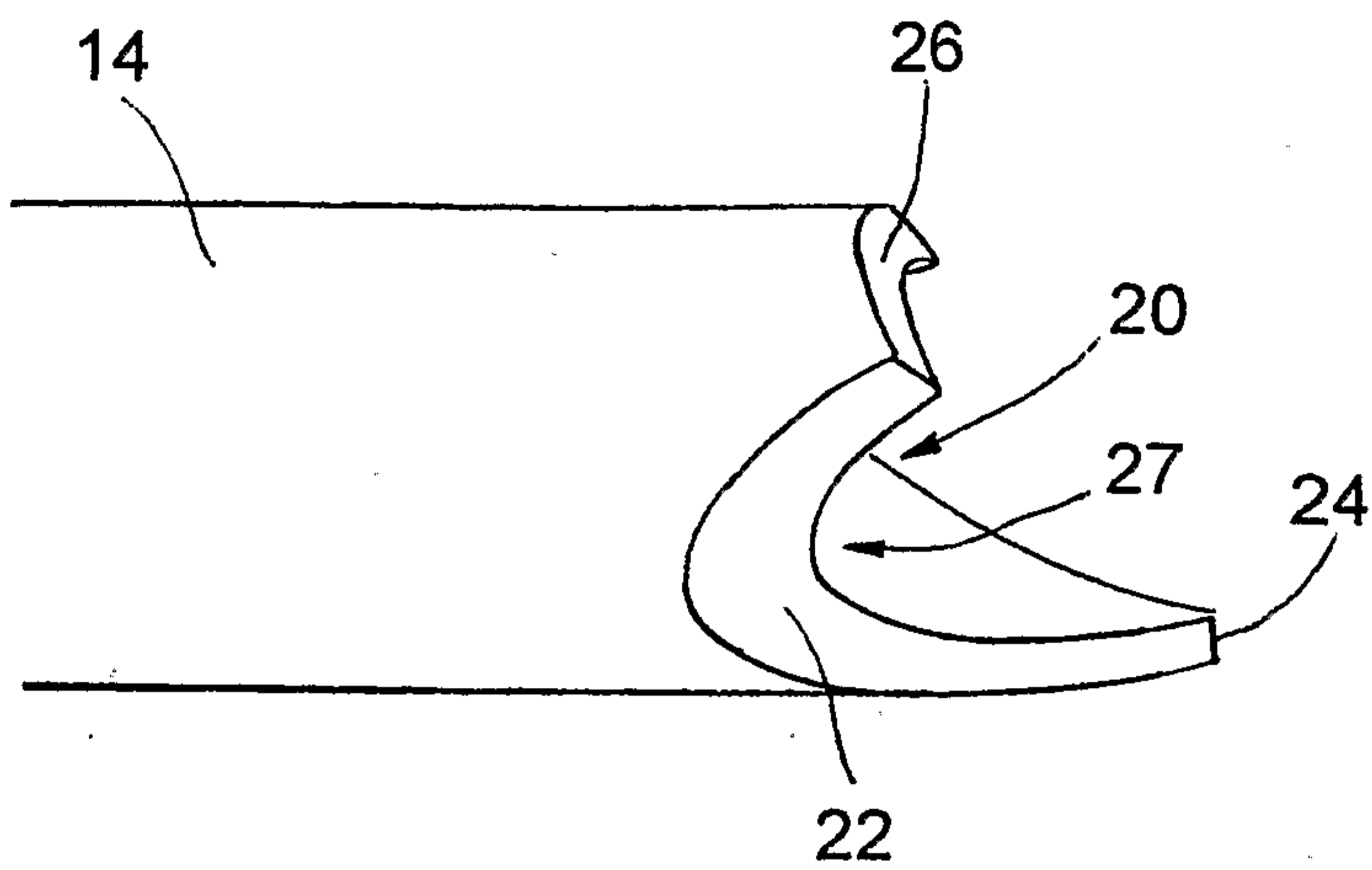

Fig. 3A

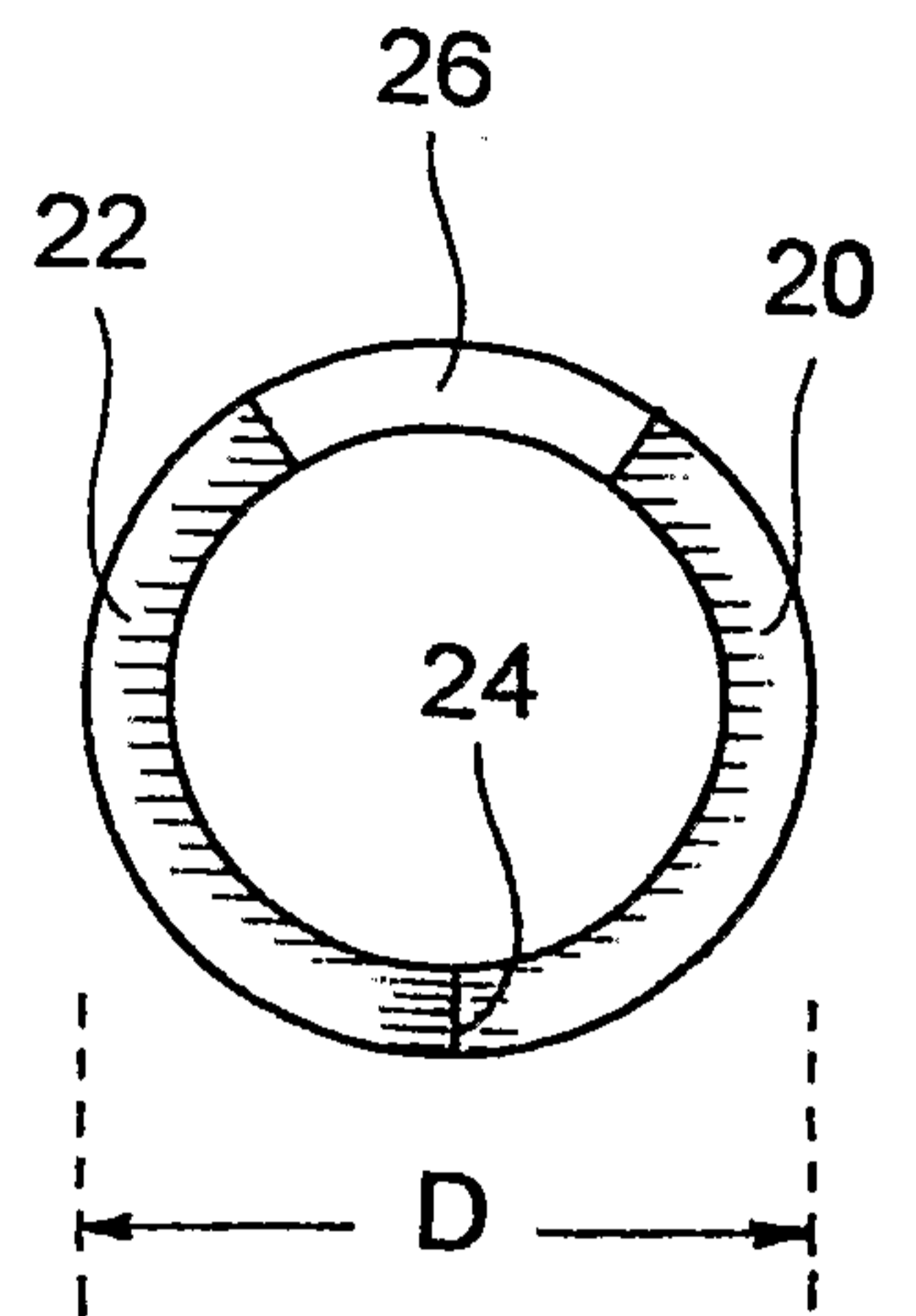

Fig. 3B

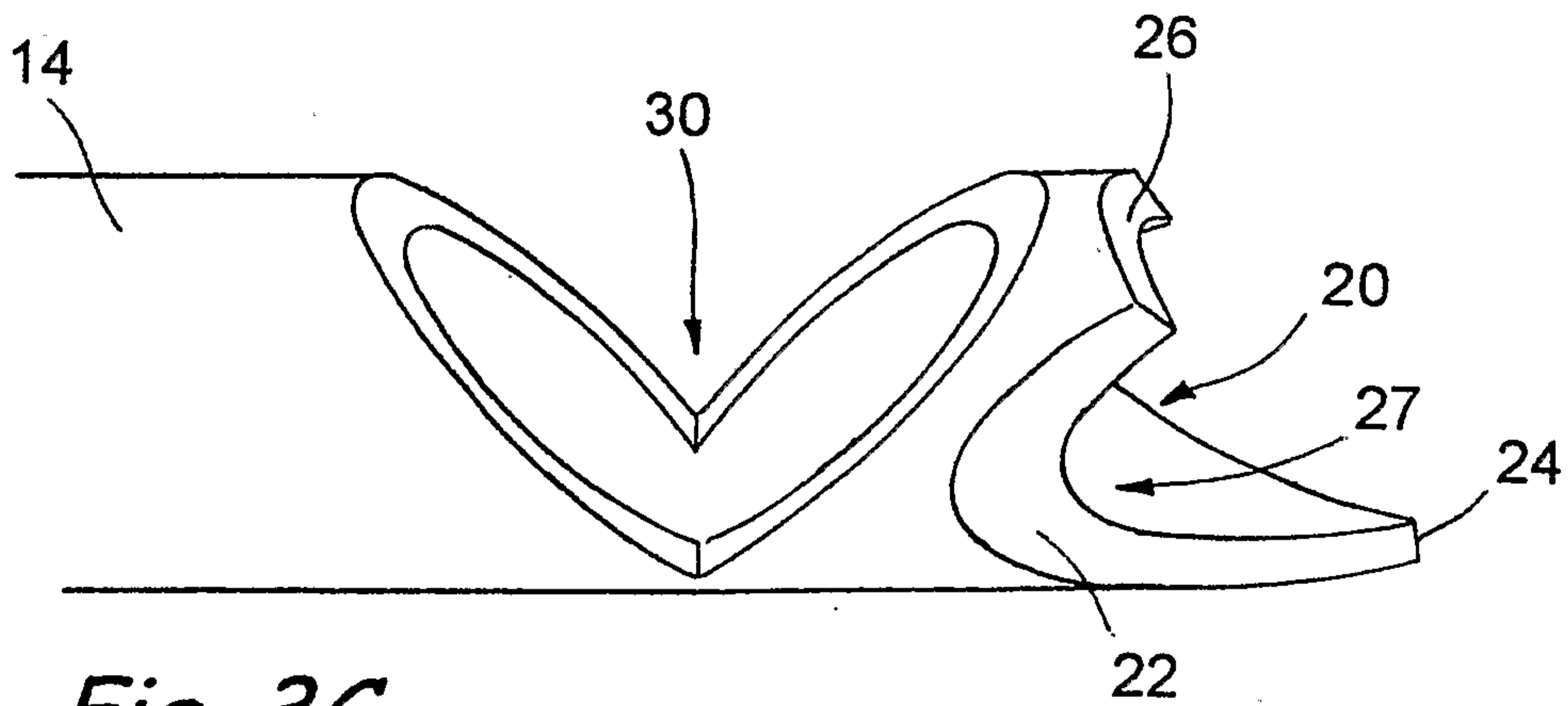

Fig. 3C

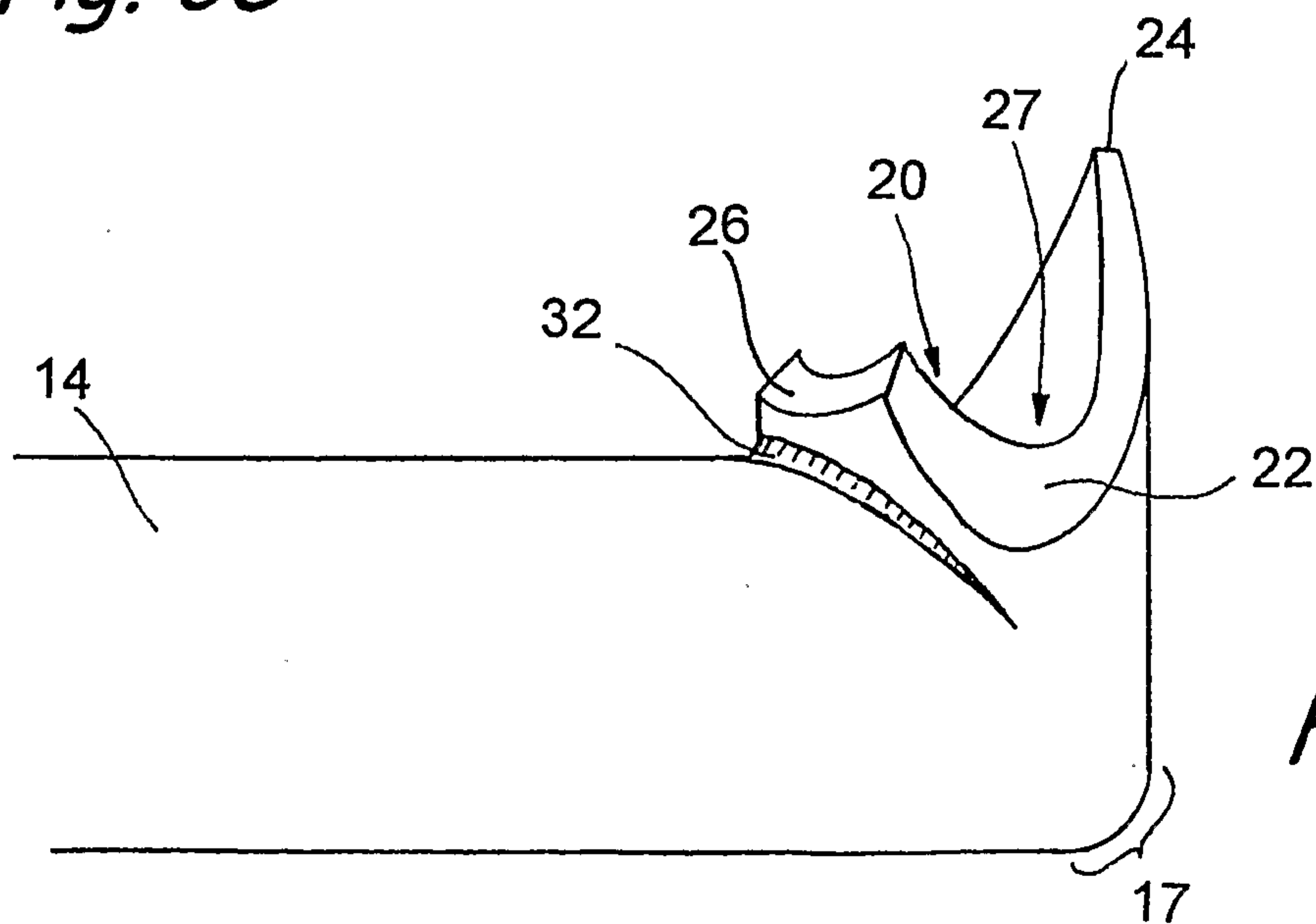

Fig. 3D

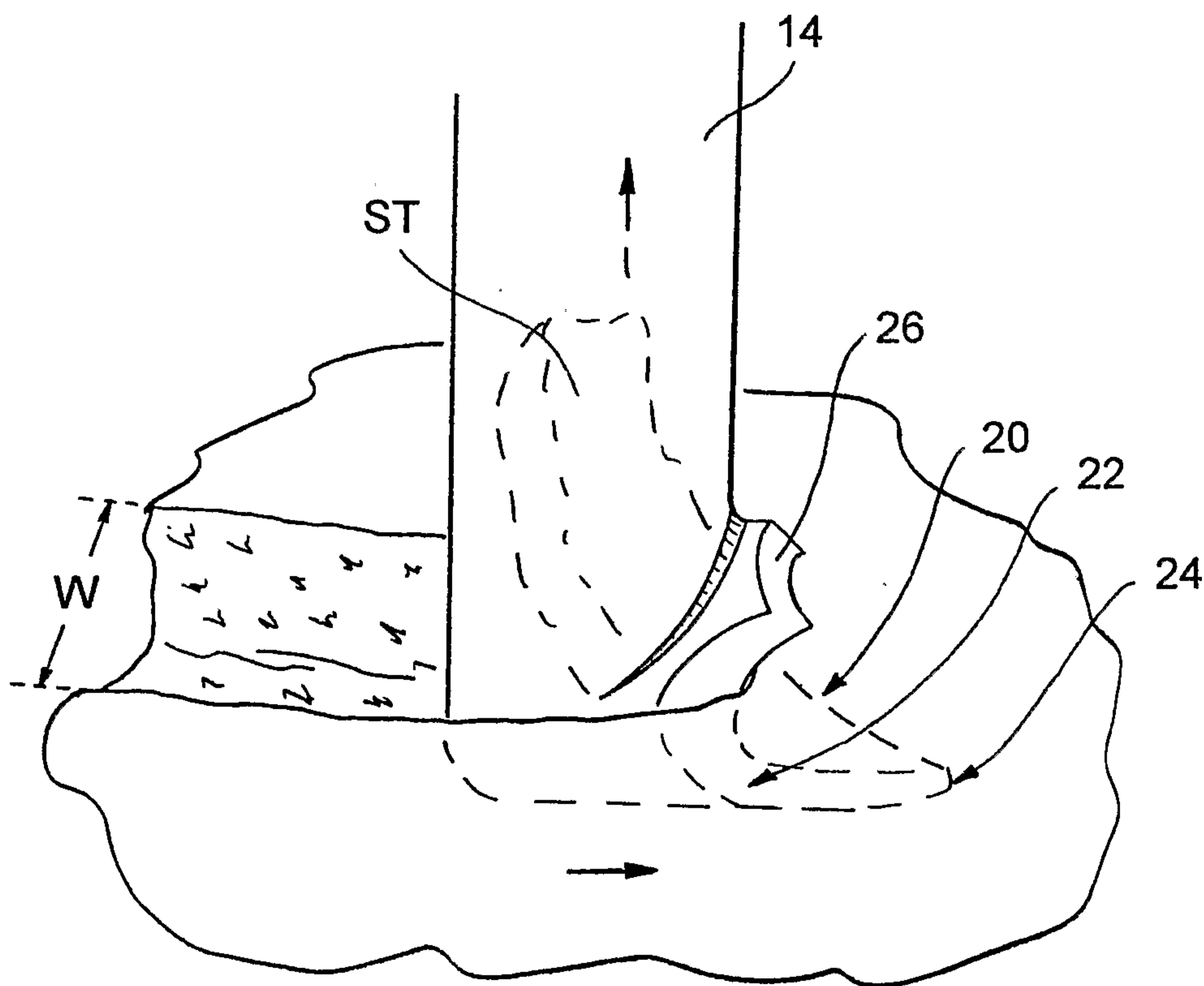

Fig. 4

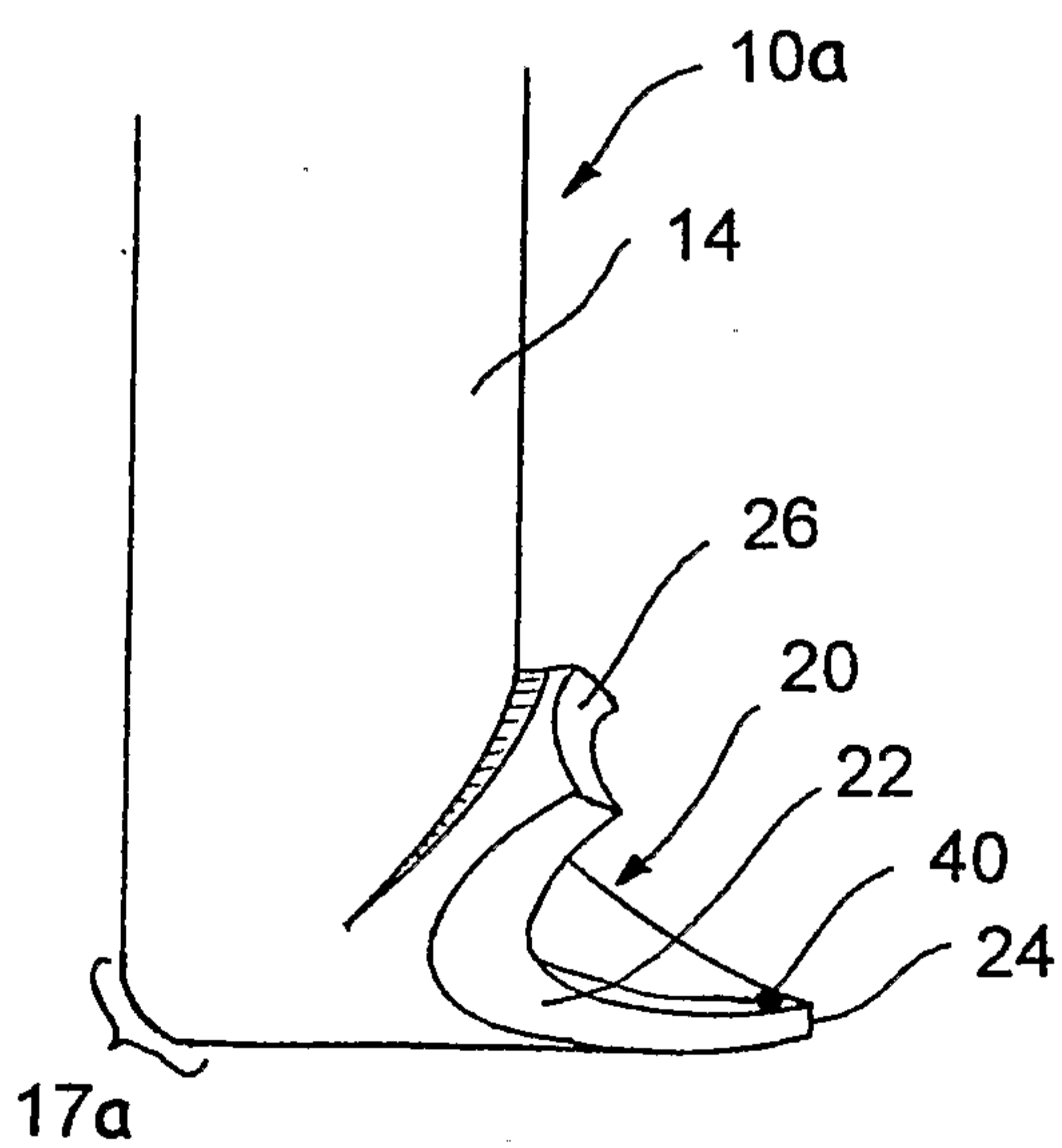

Fig. 5

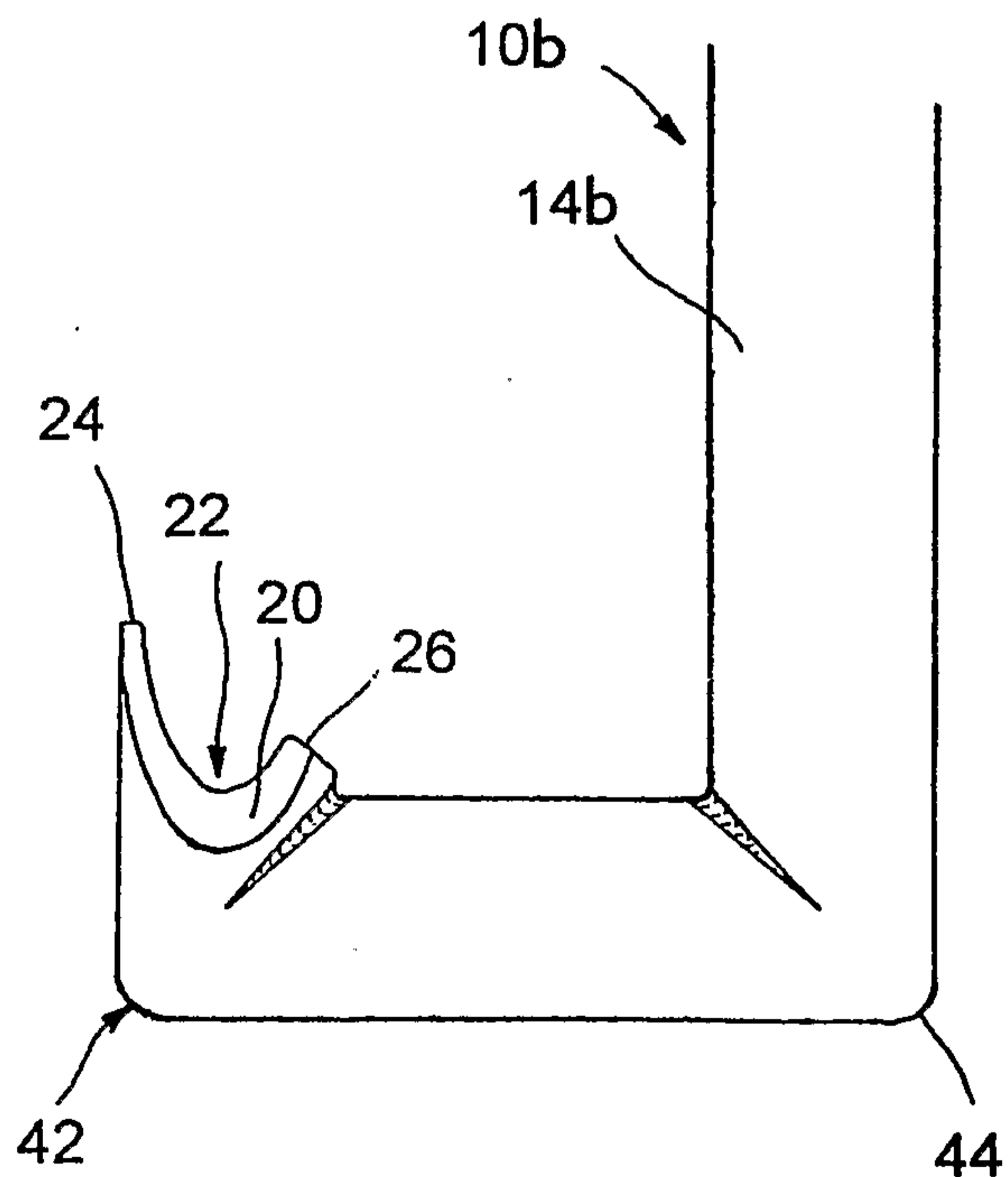

Fig. 6

