



(11) **EP 4 155 657 A1**

(12) **EUROPEAN PATENT APPLICATION**

(43) Date of publication:
29.03.2023 Bulletin 2023/13

(51) International Patent Classification (IPC):
F28F 25/06 (2006.01) **A62C 35/68** (2006.01)
B05B 3/04 (2006.01)

(21) Application number: **22197541.0**

(52) Cooperative Patent Classification (CPC):
B05B 3/0486; A62C 35/68

(22) Date of filing: **23.09.2022**

(84) Designated Contracting States:
AL AT BE BG CH CY CZ DE DK EE ES FI FR GB GR HR HU IE IS IT LI LT LU LV MC MK MT NL NO PL PT RO RS SE SI SK SM TR
Designated Extension States:
BA ME
Designated Validation States:
KH MA MD TN

(71) Applicant: **Axial Fans Int S.r.l.**
21010 Besnate (IT)

(72) Inventor: **Mosiewicz, Roberto Eduardo**
21010 Besnate (IT)

(74) Representative: **Riccardi, Sergio**
Riccardi & Co.
Via Macedonio Melloni, 32
20129 Milano (IT)

(30) Priority: **28.09.2021 IT 202100024791**

(54) **LIQUID DISTRIBUTION SYSTEM FOR COOLING OR FIRE-FIGHTING INSTALLATIONS**

(57) The invention relates to a distributor (1) of liquid for cooling or fire-fighting installations comprising: a duct (2) configured to convey a liquid parallel to its central axis (2a) suitable to be arranged, when used, at right angles to the ground; a concentrator (3) integrally connected with the duct (2) and spaced from said duct (2) along the central axis (2a) and configured to concentrate the liquid in a predetermined concentration area (3a) defined in a main plane (2b) perpendicular to the central axis (2a); a deflector (4) with a labile constraint with the concentrator (3), so that it can be rotated on the main axis (2a), in connection with fluid passage in the concentration area (3a) and configured to deflect the liquid along radial trajectories (4a) at least partially transversal to the central axis (2a), wherein the deflector (4) comprises a plurality of blades (40) extending along the radial trajectories (4a) and configured to push, when hit by the liquid, the deflector (4) so as to rotate on the main axis (2a).

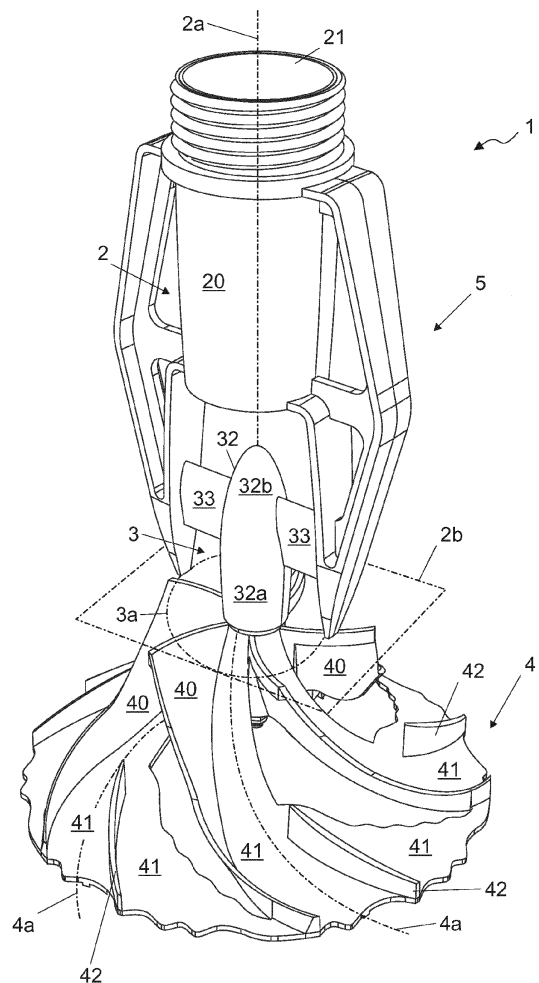

Fig. 1

EP 4 155 657 A1

Description

FIELD OF THE INVENTION

[0001] The present invention relates to a liquid distribution system for cooling or fire-fighting installations of the kind recited in the preamble of the first claim.

[0002] More particularly, the present invention relates to a distributor of a liquid such as water, suitable for being connected to pipes included in a network of external distribution.

[0003] It is well known that in industrial environments for productions processes comprising plants operating at high temperatures, it may be advisable to use also cooling systems adapted to reduce the local operative temperature of the installations.

[0004] Moreover, inside any environment, one may often find fire-fighting installations for extinguishing any flame arisen inside the environment, for instance using water or nebulized fire-fighting liquid.

[0005] Therefore, in the conventional cooling and/or fire-fighting installations, it is possible to find distributors suitable to allow the distribution of water, or other suitable liquid, in a specific form, such as droplets, cascade and so on.

[0006] Under the various kinds of distributors, atomizers and nebulizers are well known. These distributors are substantially configured to receive a fluid flow and convert it into a plurality of particles. Then, these particles are distributed rather uniformly on a surface.

[0007] The sprinklers are indeed delivering a liquid rain, generally used to extinguish fires, comprising a body, a thermosensitive element, a plug, an orifice and a baffle.

[0008] The baffle is generally installed on the body of the sprinkler, on the part opposite to the orifice.

[0009] Therefore, the baffle substantially divides the flow of water discharged from the orifice, so as to warrant a higher extinguishing power.

[0010] Other distributors, mainly used for irrigation, may instead comprise rotary baffle plates. These rotary baffle plates are active elements, controlled to rotate around its own axis, and configured to distribute water in view of the centrifugal force distributed thereon. Generally, the baffle plates comprise two opposed ducts connected to a central duct, wherefrom water flows to be discharged from the jointly rotating opposed ducts.

[0011] The described prior art has some important drawbacks. More particularly, the devices provided with atomizers or nebulizers require pressurized liquid or additional components for pressurization of the liquid reaching the outlet nozzle.

[0012] The devices provided with static baffle plates are generally not fully effective, while devices provided with rotary baffle plates comprise feeding means to control the rotary motion of the baffle plates, with obvious increase of both structural complexity and related costs.

[0013] In this situation, the basic technical problem of

the present invention is to provide a distributor of liquids for cooling or fire-fighting installations, adapted to substantially get round at least part of the above mentioned drawbacks.

[0014] Within the scope of said technical problem, it is an important object of the invention to make a liquid distribution system for cooling or fire-fighting installations, allowing to supply liquid under any pressure, for instance merely falling due to gravity.

[0015] Another important scope of the invention is to carry out a distributor of liquid for cooling or fire-fighting installations, which is simple and economic.

[0016] More particularly, it is an important object of the invention to carry out a distributor which is very efficient and at the same time does not require active controlling or feeding devices which might burden the global structure.

[0017] The abovementioned technical objects and problems are solved by a liquid distribution system for cooling or fire-fighting installations as recited in the annexed claim 1. Preferred technical solutions are pointed out in the dependent claims.

[0018] The features and advantages of the invention are hereinafter clarified by the detailed description of preferred embodiments of the invention, making reference to the accompanying drawings, in which:

Fig. 1 is a perspective view of a liquid distributor for cooling or fire-fighting installations of the invention; Fig. 2a shows a top view of the baffle plate of a liquid distributor for cooling or fire-fighting installations according to the invention;

Fig. 2b shows a bottom view of the baffle plate of a liquid distributor for cooling or fire-fighting installations according to the invention;

Fig. 3 is a detailed front sectional view of a liquid distributor for cooling or fire-fighting installation according to the invention; and

Fig. 4 is an exploded detailed view of the central parts of a liquid distributor for cooling or fire-fighting installation according to the invention.

[0019] In this document, measures, values, forms and geometrical references (such as verticality and parallelism), when associated with words like "about" or other similar terms like "almost" or "substantially", should be understood as excluding measurement errors or inaccuracies due to manufacture and/or production errors, and above all excluding a slight deviation from the associated value, measure, form or geometric reference. For instance, these terms, when associated with a value, preferably mean a deviation not higher than 10% of said value.

[0020] Moreover, when used, terms like "first", "second", "upper", "lower", "main", "secondary" do not necessarily identify an order, a priority of relation or position, but they may be simply used to clearly distinguish different components.

[0021] Unless otherwise specified, as resulting from the following discussions, it is to be noted that terms like "treatment", "information", "determination" "computation" and the like, refer to the action and/or process of a computer or similar device of electronic calculation, treating and/or transforming data represented as physical ones, such as electronic quantities of registers of an information system and/or memory into other data likewise represented as physical quantities inside information systems, registers or other devices to store, transmit or show information.

[0022] The measurements and data given in the present document are to be considered, unless otherwise stated, as obtained under International Standard Atmosphere ICAO (ISO 2533:1975).

[0023] With reference now to the figures of the drawings, the liquid distributor for cooling or fire-fighting installations according to the present invention is globally indicated with reference number 1.

[0024] The distributor 1 may also be equally used inside a cooling plant or inside a fire-fighting installation.

[0025] Generally speaking, the distributor 1 is fitted for supplying water in the form of jets and/or droplets made by acting on the water flow hitting the distributor 1.

[0026] Moreover, the distributor 1 is suitable for being connected to pipes included in an external hydraulic distribution network, so as to supply continuously the water conveyed thereinto from the external hydraulic network. Briefly, the distributor 1 comprises at least a duct 2. Duct 2 is preferably configured to convey a liquid along one direction. More particularly, duct 2 conveys the fluid parallel to or along its central axis 2a.

[0027] Central axis 2 is the axis around which duct 2 is mainly developed. Therefore duct 2 is substantially a tubular body extending along the central axis 2a.

[0028] Conveyance is preferably carried out passively. This means that the fluid, i.e. water, preferably is introduced into duct 2 autonomously, preferably by gravity. Therefore, in this connection, central axis 2a of duct 2 is suitable to be arranged at right angles to ground, when the distributor 1 is being used.

[0029] Duct 2 may also be a single piece, or may include a tubular container 20, inside which an extractible cartridge 21 may be arranged.

[0030] The tubular container 20 is a containing element preferably including a lower border, namely at an end facing the ground and configured to prevent the cartridge 21 to slide downwards. Said cartridge may be inserted into the tubular container 20 and removed therefrom, by causing the cartridge to slide along the central axis 2a. Therefore, the cartridge may be shaped externally along the tubular container 20 and may define a variable internal opening.

[0031] Indeed, it is possible to provide the distributor 1 with a spare kit comprising a plurality of different cartridges 21 defining different openings. On the whole, duct 2 and consequently the tubular container 20 and the cartridge 21 may define either a cylindrical or most preferably

truncated conical shape.

[0032] In any case, the distributor 1 comprises also a concentrator 3. The concentrator 3 substantially is a component suitable for directing the fluid into a predetermined concentration area 3a. Such a concentration area 3a is substantially an area that can be defined along a plane transversal to the central axis 2a. More particularly, the concentration area 3a is defined in a main plane 2b at right angles with the central axis 2a. Clearly the plane is a virtual element on which the concentration area 3a may still virtually be defined.

[0033] The concentrator 3 as a structure is integrally constrained to duct 2, and is spaced from duct 2 along the central axis 2a. Therefore, the fluid falling from duct 2 hits the concentrator 3 and is sent to the concentration area 3a. Thus, the concentrator 3 is just configured to concentrate the liquid in the concentration area 3a. The constraint between duct 2 and concentrator 3 may be carried out by different modes. Preferably, in a preferred embodiment, the distributor 1 may comprise a frame 5.

[0034] Frame 5 substantially is a support and connection element for duct 2 and concentrator 3. Therefore, frame 5 may be a further component to be constrained to duct 2 and concentrator 3, or it may be integral with duct 2, more particularly the tubular container 20, and with concentrator 3. Thus, in turn, at least a portion of duct 2 and concentrator 3 may be integral. Frame 5 preferably is U-shaped and therefore is configured to mutually connect duct 2 and concentrator 3, surrounding said concentrator 3.

[0035] Still in greater detail. Concentrator 3 may comprise an envelope 32 and two arms 33. The envelope 32 substantially is a preferably at least partially hollow body extending along the main axis 2a.

[0036] Moreover, envelope 32 preferably comprises a first barrel shaped portion 32a adjacent to deflector 4 and a second portion 32b defining a paraboloid shape. Therefore, envelope 32 defines a shape like an aircraft fuselage, with the front portion defined by the second portion 32b. Thus, the liquid coming from duct 2 substantially hits the second portion 32b and flows along the first portion 32a before falling on the deflector 4, like air flows around an aircraft fuselage.

[0037] Arms 33 are preferably arranged transversal, for instance perpendicular to main axis 2a. Moreover, arms 33 are integrally constrained to envelope 32 and frame 5 at the opposite sides of envelope 32.

[0038] Therefore, arms 33 define sections on planes parallel to main axis 2a, like wing contours with a leading edge facing duct 2. Thus, even the arms 33 contribute to convey the liquid, letting the same to flow on their surface in a controlled way, as it happens on the envelope 32. Therefore, the concentration area 3a substantially encloses an area including at least envelope 32 and arms 33.

[0039] The distributor 1 comprises also a deflector 4. Deflector 4 preferably has a labile constraint with concentrator 3. More particularly, deflector 4 may rotate

around the main axis 2a, for instance in respect of the concentrator 3.

[0040] Thus, the deflector 4 is arranged in connection of fluidic passage with the concentration area. This means that the deflector 4 is substantially adapted to receive the liquid passing through the concentration area 3a in order to deflect the direction of movement of said flow. Indeed, the deflector 4 is configured to deflect the liquid along radial trajectories 4a.

[0041] The radial trajectories 4a are at least partially transversal to the central axis 2a. Indeed, the radial trajectories 4a extend at least from the central axis 2a to the outside, distributed around the central axis 2a. However, the radial trajectories 4a might also extend partially parallel to the central axis 2a. Preferably, the radial trajectories 4a are extending both transversally and partially around the central axis 2a.

[0042] Advantageously, the deflector 4 comprises a plurality of blades 40. The blades 40 are extending along radial trajectories 4a. Thus, blades 40 are configured to push, when hit by liquid, deflector 4 to rotate around the main axis 2a. Therefore, the deflector 4 is thrust to rotate, preferably by gravity, by the liquid incoming from the concentration area 3a. With such a rotation, the deflector 4 allows the liquid to branch out along the radial trajectories, thus being subdivided into a plurality of streamlets, then divided into droplets.

[0043] In order to make easier this latter aspect, the radial trajectories 4a are curvilinear and diverging in respect of the central axis 2a. More particularly, they are advantageously diverging to ground. Thus, the radial trajectories 4a are at least partially helicoidal. Also the blades 40 have walls that extend at least partially in a helicoidal way.

[0044] Still in a further detail, the deflector 4 comprises also a plurality of distribution surfaces 41. The distribution surfaces 41 are preferably transversal and integral with blades 40. Moreover, the distribution surfaces 41 are substantially diverging from the central axis 2a, and each surface is configured to connect two adjacent blades 40. Therefore, the distribution surfaces substantially define the radial trajectories 4a, because the liquid flows on them, once the concentration area 3a is passed.

[0045] The deflector 4 moreover comprises a plurality of fins 42. Each fin 42 preferably is transversal and integral with a corresponding distribution surface 41.

[0046] Moreover, each fin 42 extends along curvilinear trajectories radially to the central axis 2a. For instance, each fin 42 may extend substantially along a corresponding radial trajectory 4a. Preferably, the fins 42 extend at the free end of the distribution surfaces 41. In this way, the liquid reaches the fins 42 shortly before leaving the deflector 4.

[0047] In order to warrant a correct fit of concentrator 3 and deflector 4, the distributor 1 preferably is provided with some measures. More particularly, the concentrator comprises a first central body 30. The central body 30 is substantially aligned with the central axis 2a. Thus, it is

an oblong element like for instance a pivot. Preferably, the first central body 30 comprises a stem 30a. Stem 30a is therefore aligned with the main axis 2a. Moreover, advantageously, the first central body 30 comprises also two heads 30b.

[0048] The heads 30b substantially are mutually separated by the stem 30a, and therefore are mutually spaced along the main axis 2a. Moreover, the heads 30b define greater sections along planes perpendicular to the main axis 2a in respect of the stem 30a.

[0049] The first central body 30 is particularly integral with the envelope 32. Still in greater detail, envelope 32 comprises the first central body 30, or the first central body 30 extends along the main axis 2a surrounded by envelope 32.

[0050] Deflector 4 comprises instead a second central body 43. The second central body 43 is preferably hollow. Moreover, the second central body 43 is the element around which blades 40 and distribution surfaces 41 are extending.

[0051] Preferably, the second central body 43 is configured to be connected to the first central body 30. Therefore, the latter is so inserted in the second central body 43 in such a way that the second central body 43 may rotate in respect of the first central body 30. Thus, the cavity of the second central body 43 extends along the main axis 2a so as to receive the first central body 30.

[0052] Still in greater detail, heads 30b of the central body 30 are so configured as to contact the central body 43, so that between stem 30a and second central body 43 there is a gap 31. The gap 31 substantially is the enclosed space between stem 30a, heads 30b and second central body 43.

[0053] Thus, the second central body 43, constrained with the first central body 30, is also substantially enclosed at least partially in envelope 32.

[0054] Clearly, the second central body 43 might also not be a single piece, and as shown in Fig. 3, may comprise two hollow elements being concentric with the central axis 2a, where the inner element, shown without the outer element in Fig. 4, is suitable for being connected to the first central body 30, thus providing for the gap 31. Moreover, the outer element may include an upper shoulder in order to block the translation of the inner element in respect of the central axis 2a. Thus, the second central body 43 may also comprise further elements, for instance a washer and/or a bolt, as shown in Fig. 4, to be constrained to the first central body 30 under said first central body 30, to block together with the shoulder of the first element, the translation of the inner element in respect of the outer element.

[0055] In detail, the envelope 32 is configured to surround the second central body 43, without contacting the second central body, when the distributor 1 is being used. In this way, between envelope 32 and second central body 43 there is provided a leak 34. This leak 34 therefore is an opening through which at least a portion of liquid may percolate, so as to lubricate said central bodies 30,

43.

[0056] The operation of the distributor, above described in structural terms, is the following:

In substance, the liquid is conveyed by gravity throughout the duct 2 parallel to main axis 2a; then the liquid reaches the concentrator 3, where it hits the second portion 32b of envelope 32 and the arms 33, being conveyed to the concentration area 3a. After the concentration area 3a, the liquid stands on the blades 40, so as to cause the deflector 4 to rotate, and on the distribution surfaces 41 so as to be radially conveyed along the radial trajectories 4a through the fins 42. The liquid coming out from the deflector 4 is then distributed in the form of droplets and/or intermittent stream lets.

[0057] The distributor 1 according to the invention attains important advantages. Indeed, the distributor 1 of liquid for cooling or fire-fighting installations allows to deliver liquid undergoing any pressure, advantageously through simple fall by gravity. Moreover, the distributor 1 defines a simple and economic structure. Additionally, the distributor 1 is extremely efficient and does not need active control or feeding devices that may burden the global structure.

[0058] In detail, the leak 34 allows to keep the bodies 30, 43 always lubricated. The configuration of the first central body 30 defining only two contact points, separated by the stem 30a with the second central body 43, allows to reduce considerably the vibrations of the deflector 4 during the rotations around the main axis 2a.

[0059] The invention is susceptible of variants comprised in the frame of the inventive concept defined in the annexed claims. In this environment, all the details may be replaced by equivalent elements, and the materials, forms and dimensions may be of any kind.

Claims

1. Liquid distribution system (1) for cooling or fire-fighting installations, comprising:

- a duct (2) configured to convey a liquid parallel to its central axis (2a), and arranged to be perpendicular to ground;
- a concentrator (3) constrained integral with said duct (2), and spaced from said duct (2) along said central axis (2a), and configured to concentrate said liquid in a predetermined concentration area (3a), defined in a main plane (2b) perpendicular to said central axis (2a);
- a deflector (4) having a labile connection with said concentrator (3), so as to be able to rotate around said central axis (2a), in fluid flow connection with said concentration area (3a), and configured to deflect said liquid along radial trajectories (4a) at least partially transversal to said axis (2a);
- and **characterized by** the fact that

- said deflector (4) comprises a plurality of blades (40) extending along said radial trajectories (4a) and configured to push, when hit by said liquid, said deflector (4) to rotate around said central axis (2a).

2. Distribution system (1) according to claim 1, wherein said radial trajectories (4a) are curvilinear and divergent in respect of said central axis (2a).
3. Distribution system (1) according to any preceding claim, wherein said deflector (4) comprises a plurality of distribution surfaces (41) transversal and integral with said blades (40), divergent in respect of said central axis (2a), and each configured to connect two adjacent blades (40).
4. Distribution system (1) according to claim 3, wherein said deflector (4) comprises a plurality of fins (42), each fin being transversal and integral with a corresponding distribution surface (41) and extending along curvilinear trajectories, radially to said central axis (2a), at the free ends of said distribution surfaces (41).
5. Distribution system (1) according to any preceding claim, wherein said concentrator (3) comprises a first central body (30) aligned with said central axis (2a), and said deflector (4) comprises a second central hollow body (43), along which said blades (40) and said distribution surfaces (41) are extended, in which said first central body (30) is inserted, in such a way that said second central body (43) may rotate in respect of said first central body (30).
6. Distribution system (1) according to claim 5, wherein said first central body (30) comprises a stem (30a) aligned with said central axis (2a) and two heads (30b), spaced by said stem (30a), and defining main sections along planes perpendicular to said central axis (2a) in respect of said stem (30a), and configured to contact said second central body (43), in such a way that a gap (31) is present between said stem (30a) and said second central body (43).
7. Distribution system (1) according to any of claims 5 - 6, wherein said concentrator (3) comprises an envelope (32) extending along said central axis (2a), including said first central body (30) and configured to surround said second central body (43), without contacting said second central body (43), when said system (1) is operative, so as to form a leak (34), through which at least a portion of said liquid may percolate. So as to lubricate said central bodies (30, 43).
8. Distribution system (1) according to claim 7, wherein said envelope (32) comprises a first portion (32a)

having the shape of a barrel and adjacent to said deflector (4), and a second portion (32b) having the form of a paraboloid.

9. Distribution system (1) according to any preceding claim, comprising a frame (5) having a U shape, and configured to mutually connect said duct (2) and said concentrator (3), surrounding said concentrator (3). 5
10. Distribution system (1) according to any preceding claim, wherein said concentrator (3) comprises two arms (33), transversal to said central axis (2a), and integrally constrained to said envelope (32) and to said frame (5) at opposite sides of said envelope (32), and defining sections on planes parallel to said central axis (2a), with a shape like a wing contour, with leading edge facing said duct (2). 10 15

20

25

30

35

40

45

50

55

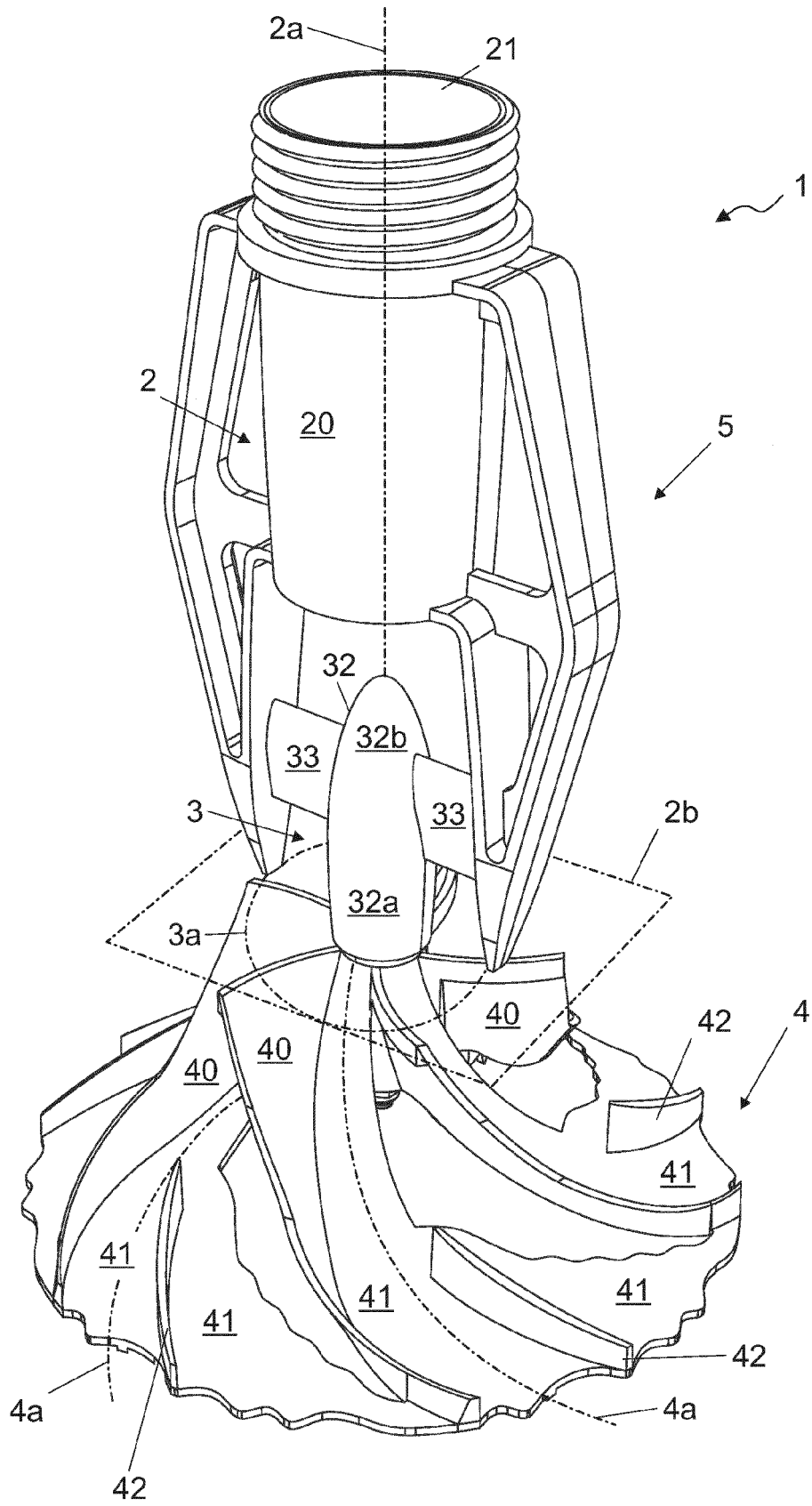
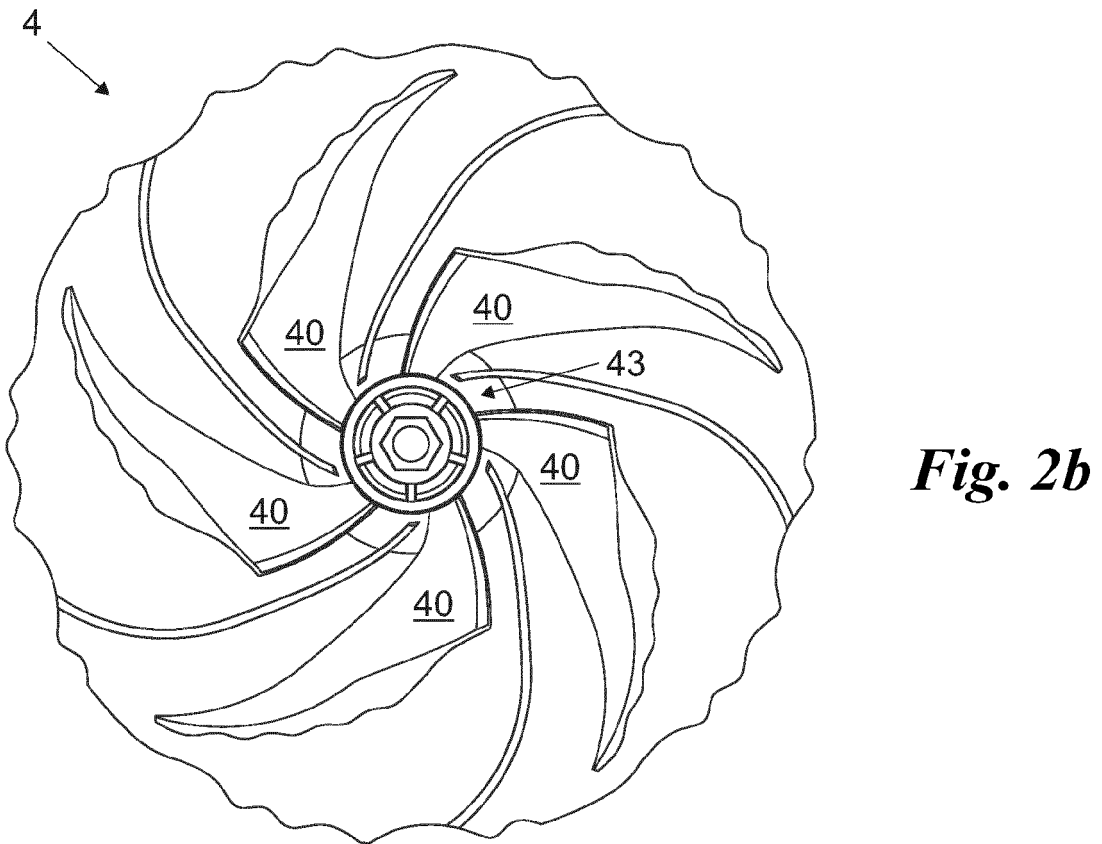
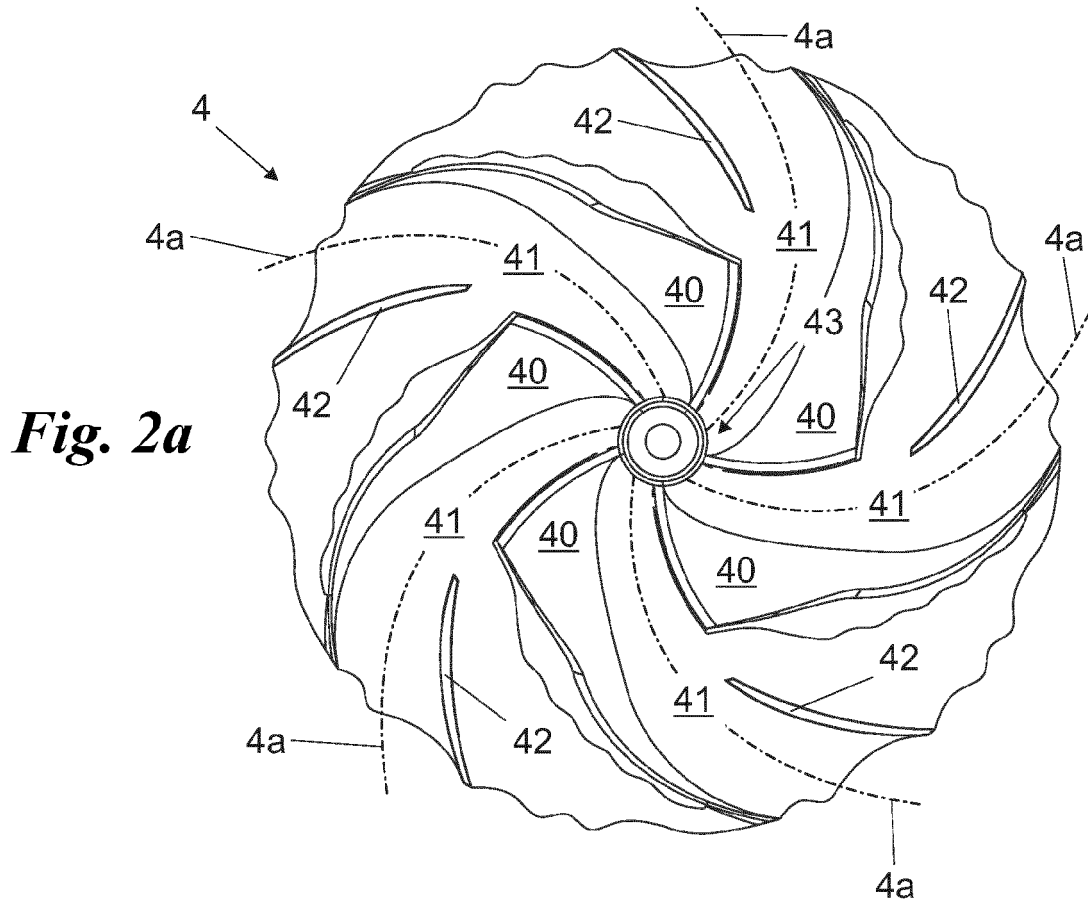

Fig. 1



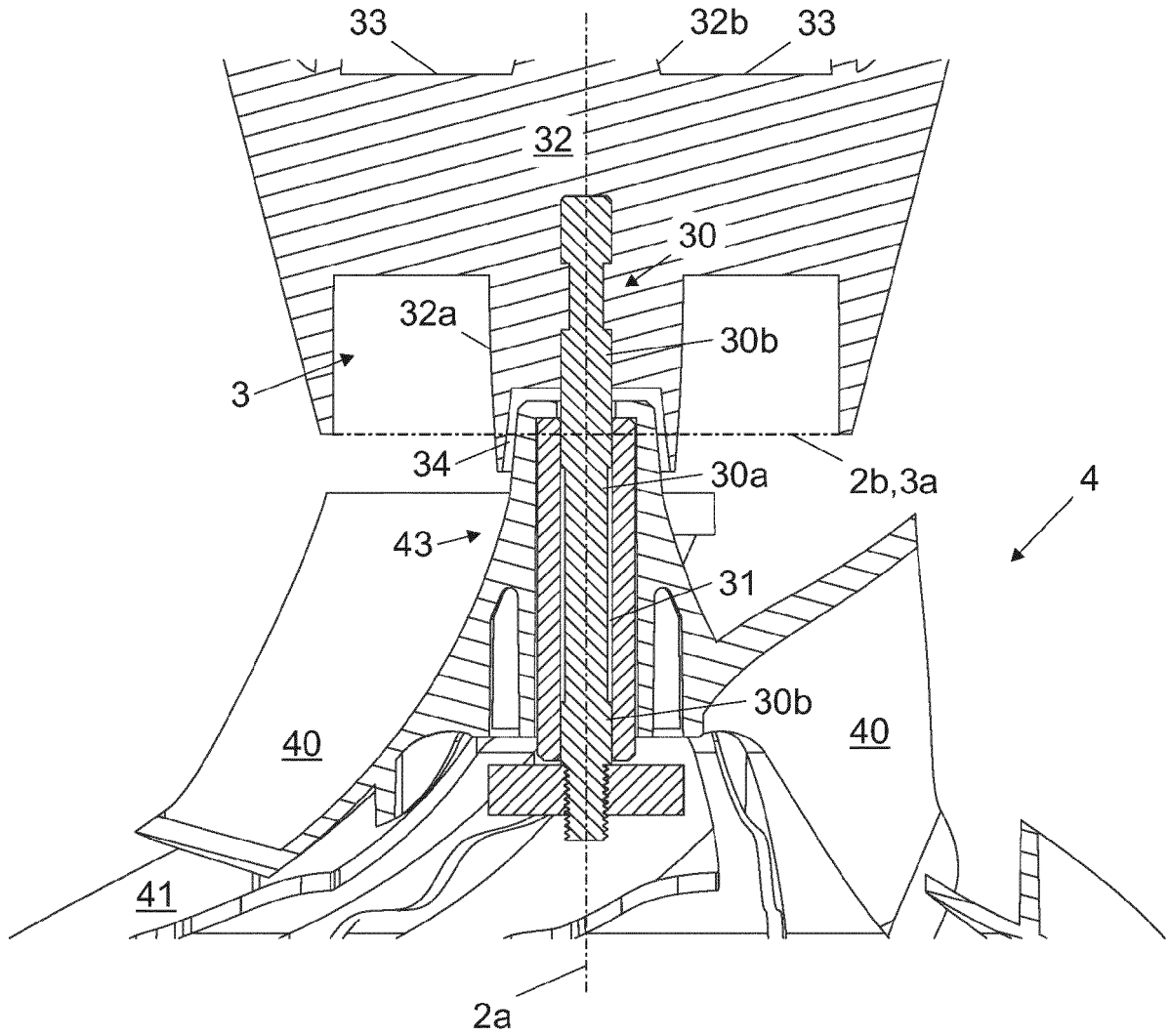

Fig. 3

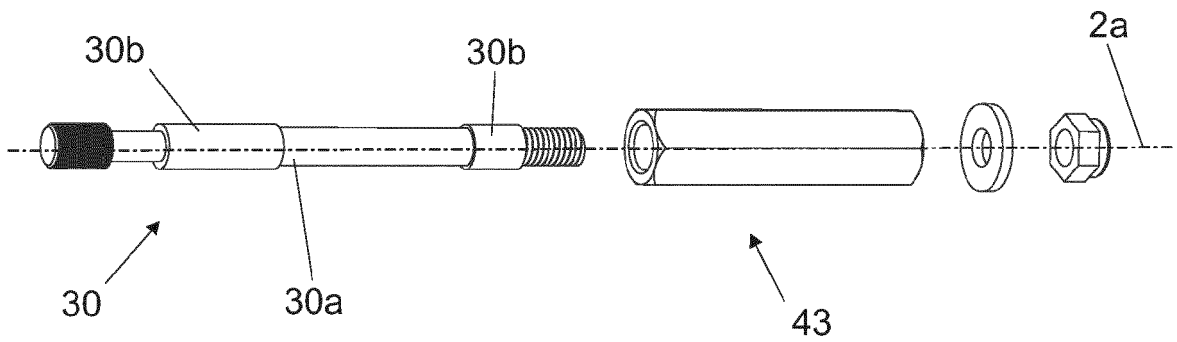

Fig. 4



EUROPEAN SEARCH REPORT

Application Number

EP 22 19 7541

5

10

15

20

25

30

35

40

45

50

55

DOCUMENTS CONSIDERED TO BE RELEVANT			
Category	Citation of document with indication, where appropriate, of relevant passages	Relevant to claim	CLASSIFICATION OF THE APPLICATION (IPC)
X	US 5 152 458 A (CURTIS HAROLD D [US]) 6 October 1992 (1992-10-06) * the whole document * -----	1-4	INV. F28F25/06 A62C35/68 B05B3/04
X	US 2004/195359 A1 (CURTIS HAROLD D [US]) 7 October 2004 (2004-10-07) * the whole document * -----	1-5	
X	US 2020/215557 A1 (SHADBOLT LEE JAMES [US] ET AL) 9 July 2020 (2020-07-09)	1-7	
A	* the whole document * -----	8-10	
			TECHNICAL FIELDS SEARCHED (IPC)
			F28F B05B
The present search report has been drawn up for all claims			
Place of search Munich		Date of completion of the search 19 January 2023	Examiner Bork, Andrea
CATEGORY OF CITED DOCUMENTS X : particularly relevant if taken alone Y : particularly relevant if combined with another document of the same category A : technological background O : non-written disclosure P : intermediate document		T : theory or principle underlying the invention E : earlier patent document, but published on, or after the filing date D : document cited in the application L : document cited for other reasons & : member of the same patent family, corresponding document	

2
EPO FORM 1503 03:82 (F04C01)

**ANNEX TO THE EUROPEAN SEARCH REPORT
ON EUROPEAN PATENT APPLICATION NO.**

EP 22 19 7541

5 This annex lists the patent family members relating to the patent documents cited in the above-mentioned European search report.
The members are as contained in the European Patent Office EDP file on
The European Patent Office is in no way liable for these particulars which are merely given for the purpose of information.

19-01-2023

Patent document cited in search report	Publication date	Patent family member(s)	Publication date
US 5152458 A	06-10-1992	CA 2068273 A1	14-12-1992
		DE 69204913 T2	04-04-1996
		EP 0518579 A2	16-12-1992
		US 5152458 A	06-10-1992

US 2004195359 A1	07-10-2004	NONE	

US 2020215557 A1	09-07-2020	NONE	

EPO FORM P0459

For more details about this annex : see Official Journal of the European Patent Office, No. 12/82