

(No Model.)

2 Sheets—Sheet 1.

D. STUCK.  
DENTAL CHAIR.

No. 522,922.

Patented July 10, 1894.

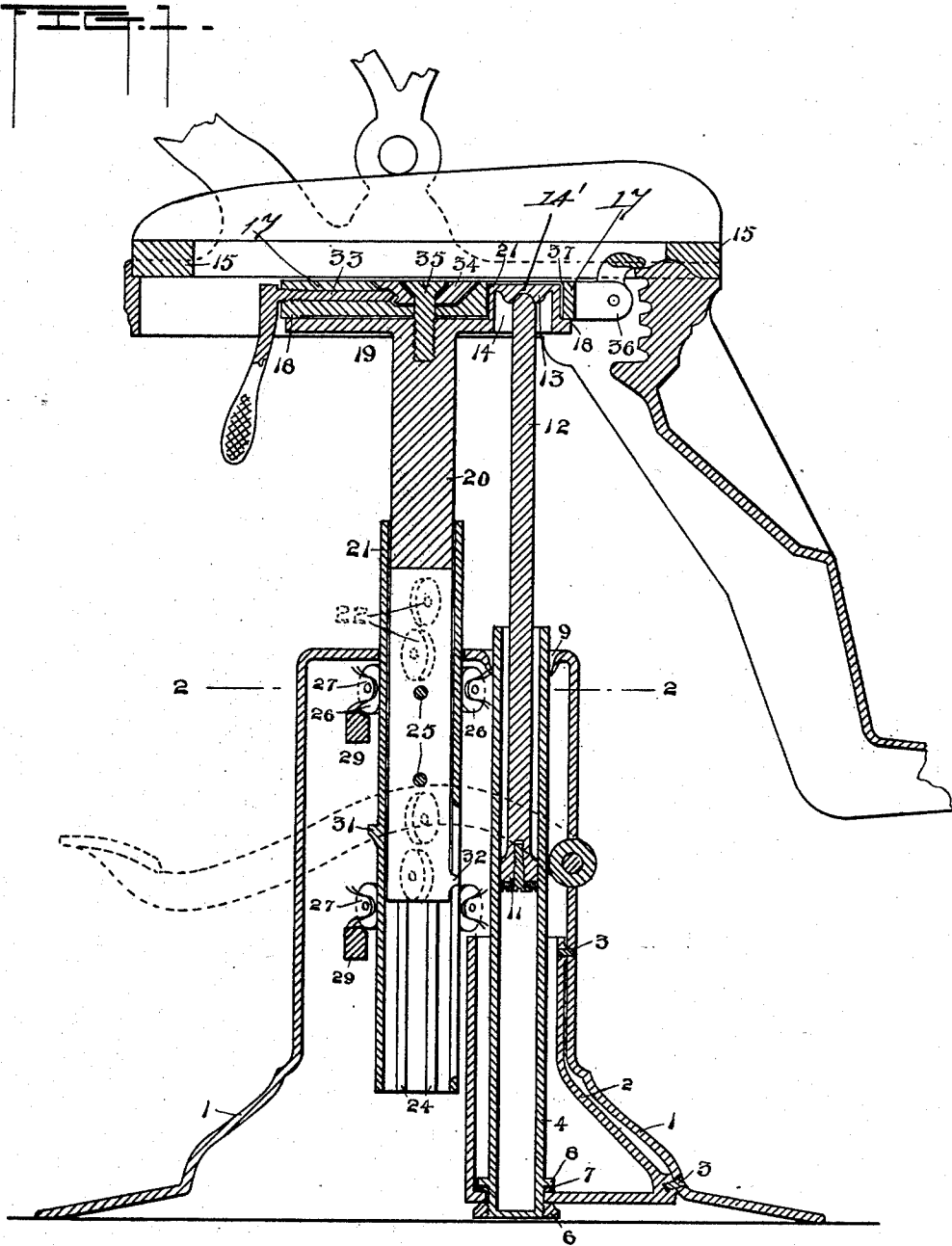

Witnesses  
Arch. M. Cattin.  
Frank D. Blackstone.

Inventor  
Dewell Stuck  
by  
Rey. R. Cattin Attorneys

D. STUCK.  
DENTAL CHAIR.

No. 522,922.

Patented July 10, 1894.

FIG. 4.

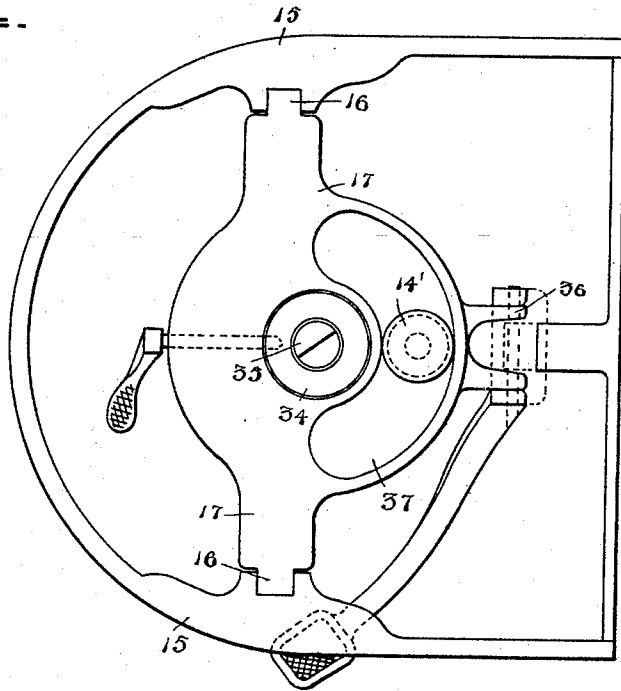

FIG. 5.

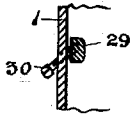

FIG. 2.

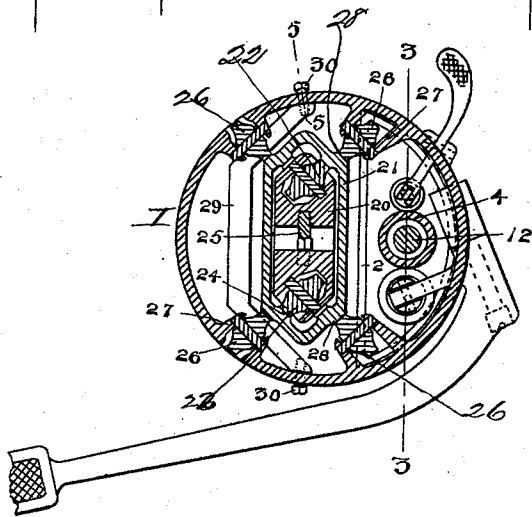
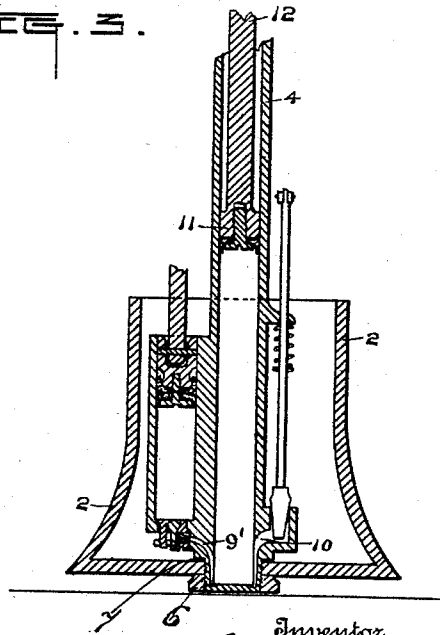

FIG. 3.



Witnesses  
 Arch. M. Catlin  
 Frank D. Bloodstone.

Inventor  
 Dwell Stuck  
 by  
 Newj. R. Catlin Attorney

# UNITED STATES PATENT OFFICE.

DEWELL STUCK, OF ROCHESTER, NEW YORK.

## DENTAL CHAIR.

SPECIFICATION forming part of Letters Patent No. 522,922, dated July 10, 1894.

Application filed October 18, 1893. Serial No. 488,469. (No model.)

*To all whom it may concern:*

Be it known that I, DEWELL STUCK, a resident of Rochester, in the county of Monroe and State of New York, have invented certain new and useful Improvements in Dental Chairs; and I do hereby declare the following to be a full, clear, and exact description of the invention, such as will enable others skilled in the art to which it pertains to make and use the same.

The invention relates to dentists' chairs and has for its object to provide efficient means for raising and lowering the seat that will permit a larger range of movement than usual heretofore. In some cases a large range has been secured by extending the raising and lowering mechanism through the floor that supported the chair. Parallel seat supporting arms moved by power transmitted through gears have been proposed and such arms have been raised and lowered by a liquid column for the purpose named.

The present invention utilizes a liquid column to directly move the seat through a large range without employing the system of parallel levers heretofore proposed and it consists in the construction hereinafter described and particularly pointed out.

In the accompanying drawings Figure 1 is a vertical section. Fig. 2 is a transverse section on line 2—2 of Fig. 1. Fig. 3 is a vertical section on line 3—3 of Fig. 2; the chair base being omitted. Fig. 4 is a plan of the seat frame and its support, and Fig. 5 is a partial section of the base showing on an enlarged scale a friction-device adjusting screw.

Numeral 1 denotes the chair base and 2 a liquid reservoir secured therein by screws 3. Within this reservoir is removably fastened a cylinder 4 the screw threaded and closed end or foot of which extends through the bottom of the reservoir and is there fastened by a nut 6.

7 denotes a packing between the flange 8 of the cylinder 4 and the bottom of the reservoir 2. The upper end of the cylinder extends through and is suitably held in an opening 9 in the top of the base. Oil or other fluid is forced into the cylinder 4 through the port 9' and allowed to escape through port 10 according as it is desired to raise and lower the chair the devices for effecting these op-

erations being of well known character. In the present instance the ports communicate with the cylinder below the level of the bottom of the reservoir, the cylinder extending below said bottom, the construction being such that piston 11 may also descend below said level to increase the downward range of the seat movement.

The seat is moved vertically through the medium of a piston 11 and piston rod 12. The upper end of the latter, which is preferably rounded, bears in a similar socket 13 situated at the upper part of a recess 14, formed in the head 19 of a part 20 of a telescoping guide or standard, said upper end being substantially in the lower plane of the upholstered seat. The recess is of a size adapted to receive the upper end of the cylinder 4.

The seat frame 15 is supported and adapted to turn on the trunnions 16 of a cross bar 17 which rests as indicated at 18, 18, upon the head 19 of the telescoping guide which consists of a solid bar 20 which is integral with the head 19 and a tubular part 21 surrounding said bar and having in transverse section an oblong and approximately lozenge shape.

Within the tube 21 the bar is bifurcated and provided with guide wheels or rollers 22 preferably eight in number journaled in the limbs of the bar 20. These wheels are adapted to bear on suitable tracks 24 formed on the interior of the tube 21, and to guide the bar in its lengthwise movements.

25 denote right and left hand screws adapted to slightly vary the relative distance of the legs of the bar 20 for the purpose of causing the wheels to bear with more or less force upon the tube as found desirable in practice and to compensate for wear.

The tube 21 is guided by wheels 26 journaled in brackets 27 fixed to the interior of the chair base. These are preferably eight in number and bear on tracks 28.

29 denotes a friction device which can be made to bear on wheels 26 with greater or less force by means of screws 30 to compensate for wear and maintain a suitable degree of friction. To permit the raising and lowering of the friction bar through the slight distance required to vary the friction, the screws are arranged in an inclined direction.

31 denotes a stop on tube 21 adapted to strike the upper part of the base and prevent the further ascent of the tube and 32 is a stop fast on the bar 20 and movable in a slot in the tube to limit both ascent and descent of the bar with relation to the tube.

The bar 20 of the telescoping guide is adapted to be clamped to the cross bar or seat frame support 17 by a screw 33 which can be turned to force a frusto-conical washer 34 against a screw or other part 35 fast on the bar 20. 36 36 are lugs fixed on said cross bar to support the fulcrum of a locking lever adapted to engage a rack connected with the seat frame.

37 denotes a recess in an enlarged part of the cross bar 17 and extending preferably through nearly or a little less than half a circle. The extension 14' of the head 19, in which the recess 14 is formed, is situated in the recess 37 and limits the rotary motion of the seat frame support 17 upon the head 19.

The above described construction is such that the piston 11 can descend below the bottom of the liquid reservoir and that the cylinder 4 may at such time reach near to the upper plane of the seat support, the range of the chair seat movement in vertical lines being only limited to the length of the cylinder, the telescoping guide and its stops being suitably arranged to permit the full movement.

The telescoping guide combined with the seat elevating piston affords a stable support to the seat and suitably directs its movements in vertical lines notwithstanding the fact that the center of gravity of the chair and its occupant is subject to considerable change.

I am aware that a seat frame and a seat support have been combined with a spring-held pin adapted to enter one of a series of holes to lock the two in a position corresponding to the situation of said hole and I do not broadly claim locking devices for this purpose but only the particular construction pointed out which avoids the use of a spring and the necessity of holding the pin out of engagement when the seat is rotated more than the distance between two holes and also permits a finer adjustment of the seat. My special arrangement also provides a lock, above the lower plane of the seat bar, so as not to interfere with the lowering of the seat to the lowest practicable point.

I am also aware that a seat elevating support has been combined with an attached cylinder partly immersed in a liquid contained in another cylinder to retard the descent of the seat and operating as a guide and I do not broadly claim devices of this nature.

Having thus fully described my invention, what I claim is—

1. In a dental chair, a base a guide tube 21 a seat guiding bar 20 having a recessed extension 14, the seat frame comprising the frame-supporting cross bar having a recess opening 37 to receive said extension, a seat-elevating rod adapted to enter the recess in the extension and devices for raising the rod, all combined substantially as set forth whereby the chair seat is guided, its vertical range enlarged, and whereby its rotation is limited.

2. In a dental chair the combination of the base, the seat frame, a guide rod 20 and a telescoping guide 21 each made movable in the base, friction wheels interposed between the telescoping parts and also between the guide 21 and the base said latter guide having tracks for the wheels, and seat-elevating and supporting mechanism, substantially as set forth.

3. In a dental chair the combination of the base, the seat frame, a guide rod 20 and a telescoping guide 21 each made movable in the base, friction wheels interposed between the telescoping parts and also between the guide 21 and the base, said latter guide having tracks for the wheels, a friction device adapted to bear on the wheels connected to the base, and seat-elevating and supporting mechanism, substantially as set forth.

4. In a dental chair the combination of a base 1, a cylinder extending above the base, a piston rod, a recessed seat-frame bar, a guide rod 20 and a telescoping guide 21 each made movable in the base and the guide rod provided with a flat head directly supporting the seat frame bar both bar and head being recessed to permit the rod and cylinder to extend above the bottom of the cross bar, all substantially as set forth.

5. In a dental chair the combination of the cross bar to support the seat frame, a vertical bar supporting said cross bar, a headed bolt secured to the top of the vertical bar and extending through the cross bar, a frusto-conical washer adapted to bear upon the under side of the bolt head, and a screw situated in the cross bar to force the washer against the head and lock the bars together, the head, washer and screw being situated above the bottom of the seat frame, substantially as set forth.

In testimony whereof I have signed this specification in the presence of two subscribing witnesses.

DEWELL STUCK.

Witnesses:

MERTON E. LEWIS,  
F. I. GLEASON.