



US 20030056797A1

(19) **United States**

(12) **Patent Application Publication**
Strong

(10) **Pub. No.: US 2003/0056797 A1**

(43) **Pub. Date: Mar. 27, 2003**

(54) **ANTI-SNORING DEVICE AND METHOD OF MAKING SAME**

Publication Classification

(76) **Inventor: Patrick J. Strong, Kingsville (CA)**

(51) **Int. Cl.⁷ A61B 19/00**

(52) **U.S. Cl. 128/861**

Correspondence Address:
Law Offices of David P. Gordon
Attention: David P. Gordon
65 Woods End Road
Stamford, CT 06905 (US)

(57) **ABSTRACT**

(21) **Appl. No.: 10/157,301**

(22) **Filed: May 29, 2002**

Related U.S. Application Data

(62) **Division of application No. 09/881,928, filed on Jun. 15, 2001, now Pat. No. 6,418,933.**

An anti-snoring device has maxillary and mandibular bite forms with outwardly extending pivots which are mounted to the bite forms by frameworks which are at least partially embedded in the bite forms. This retains the pivots securely in place even in the face of extensive bruxing. In constructing the device, a jig may be used for positioning the pivots. The method of manufacturing the device involves casting the frameworks, such that each framework has a pair of pivot mounts, mounting pivots to the pivot mounts, and at least partially embedding the frameworks in the bite forms.

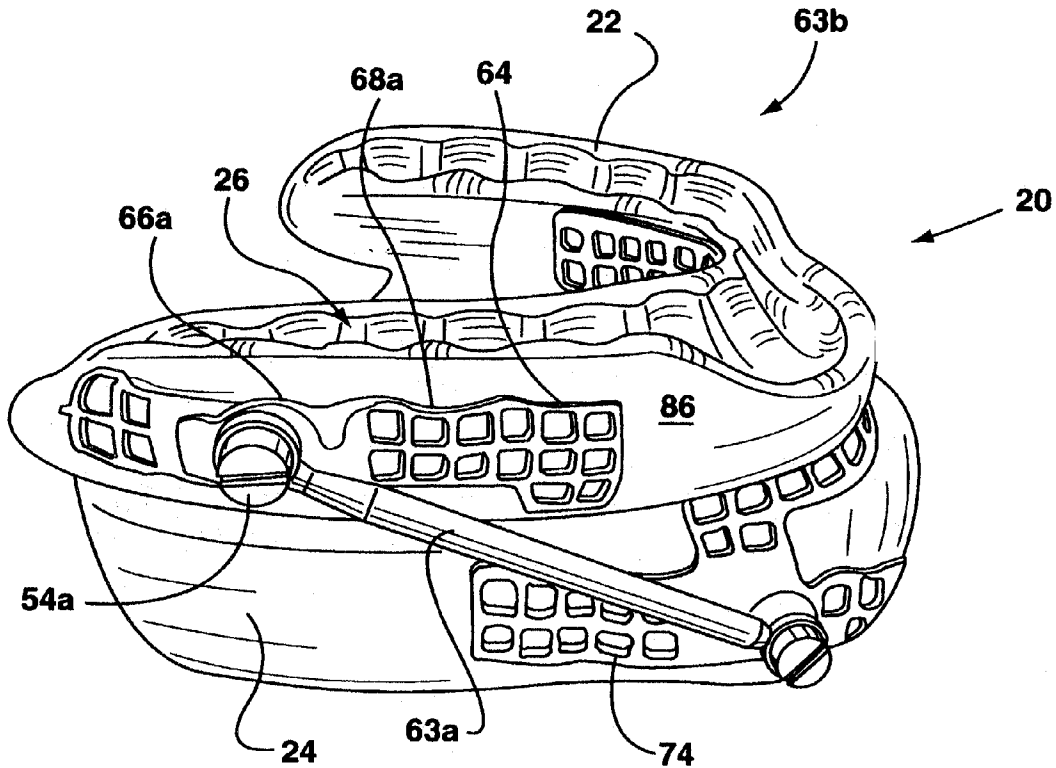

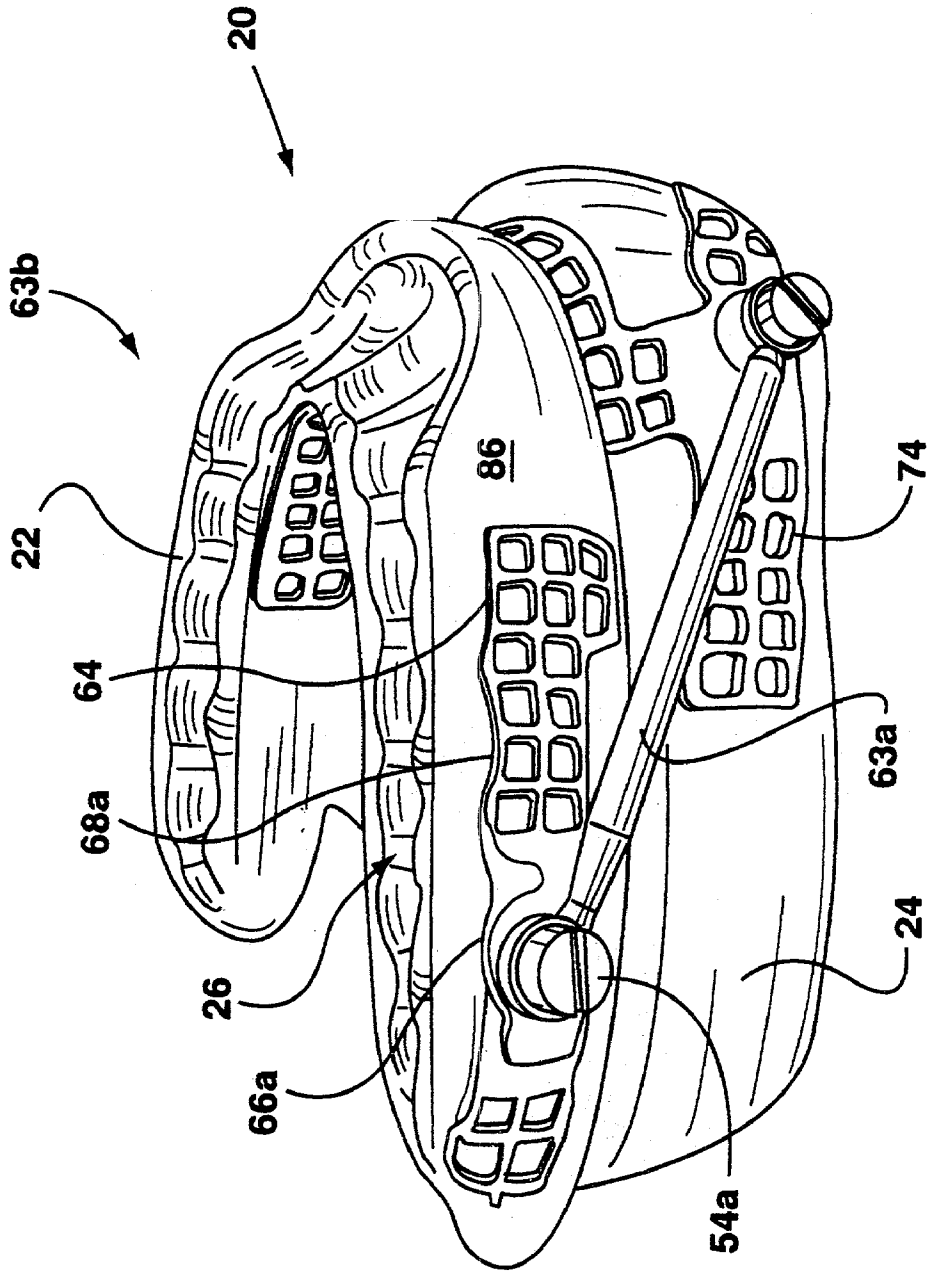

FIG. 1

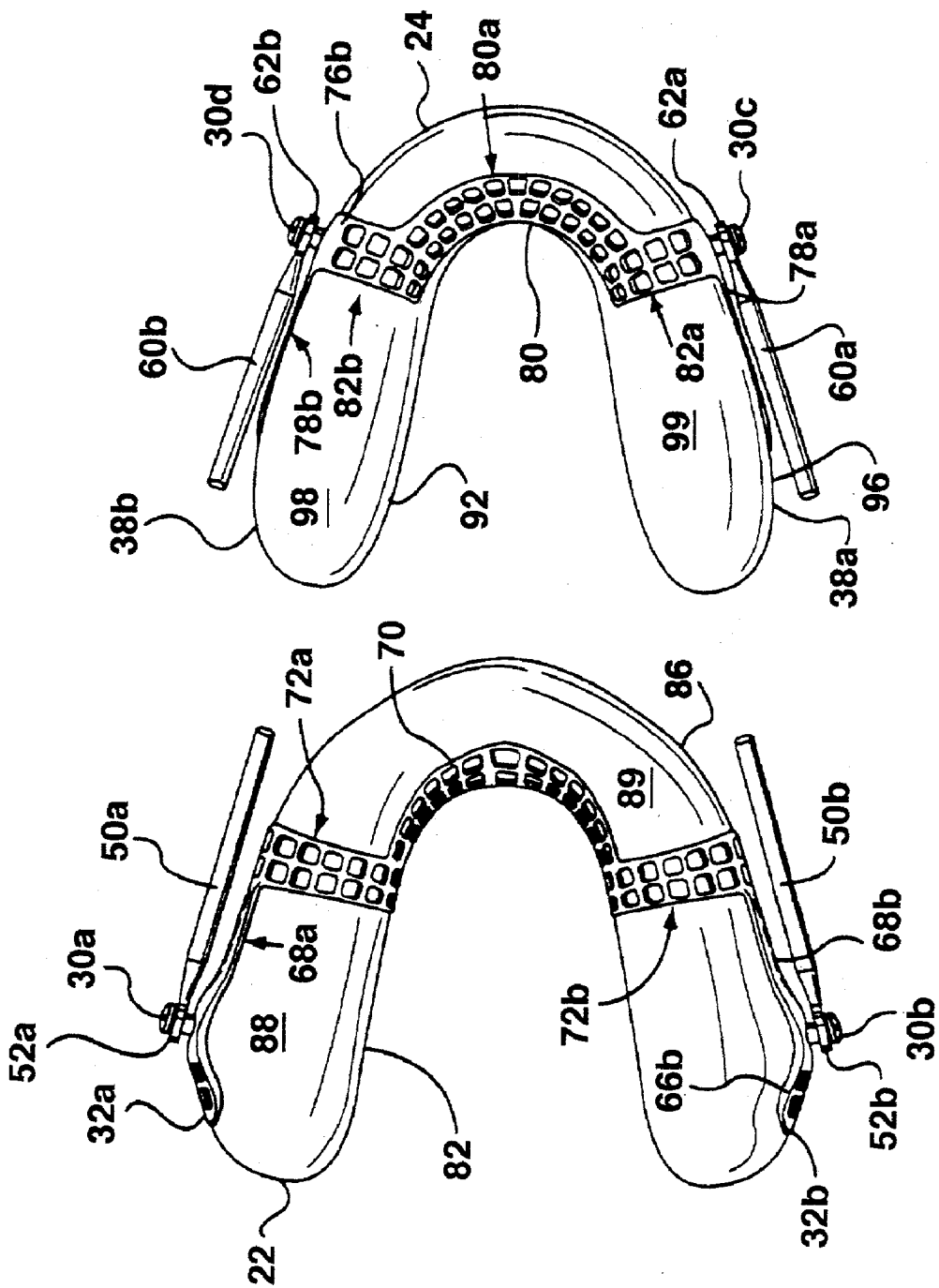
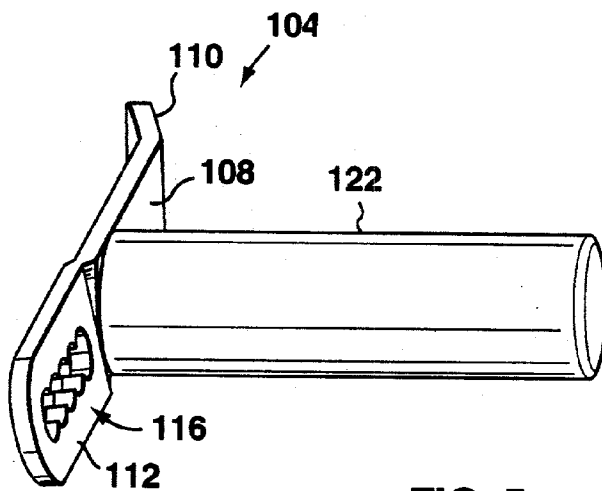
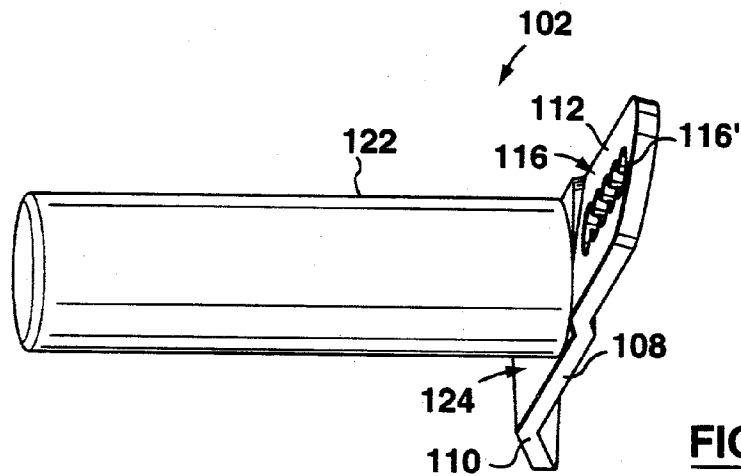
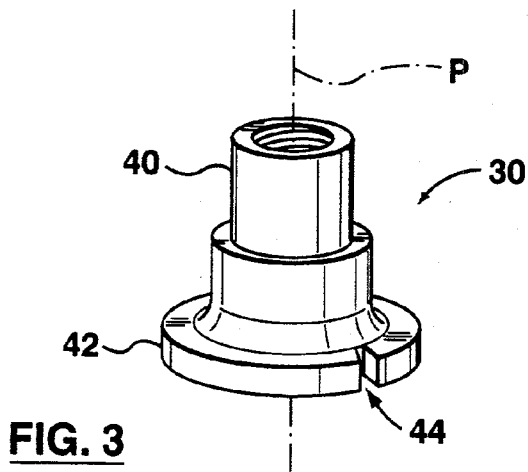
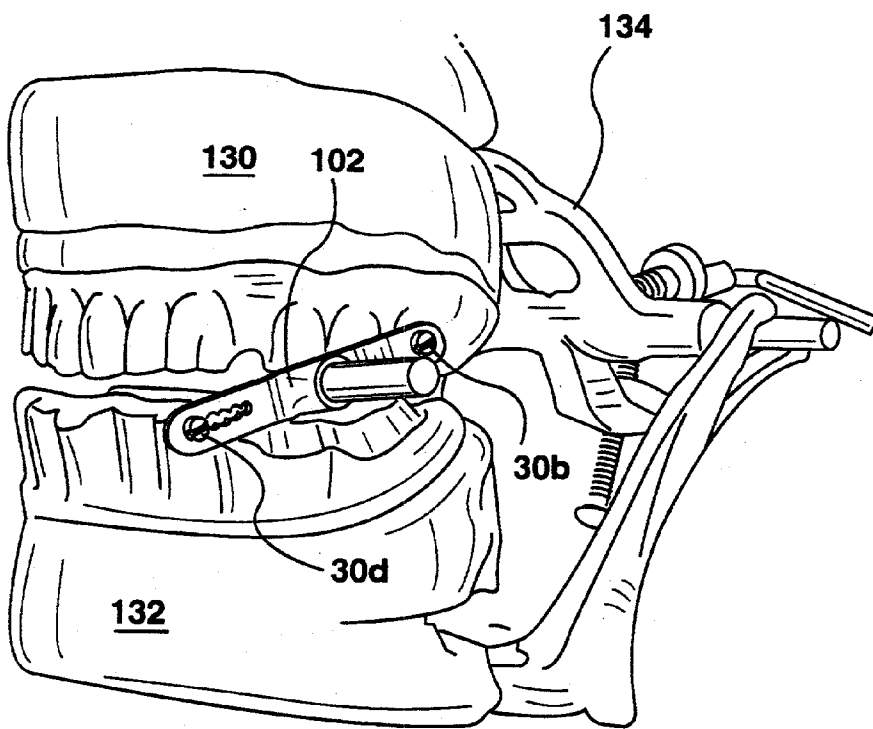
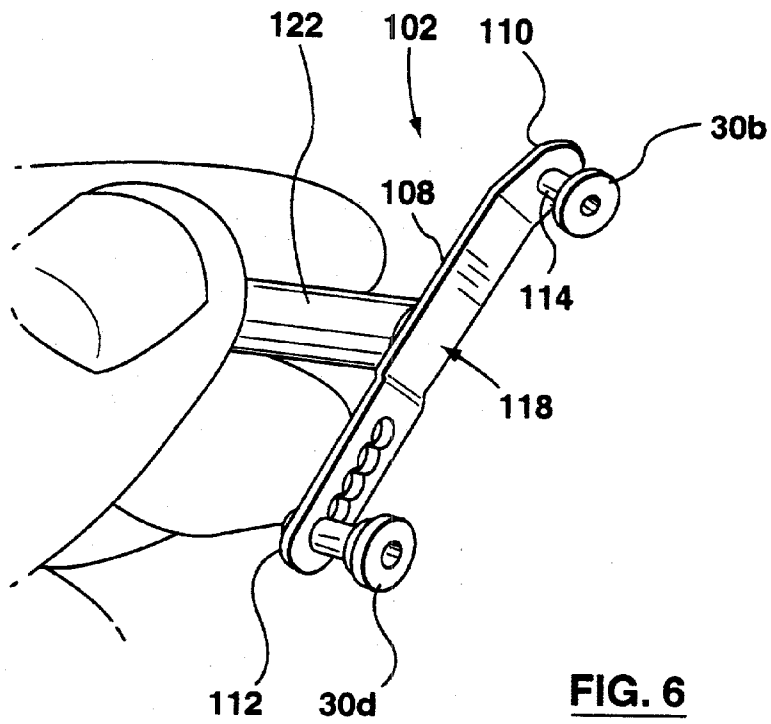

FIG. 2





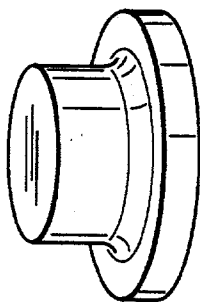

FIG. 8

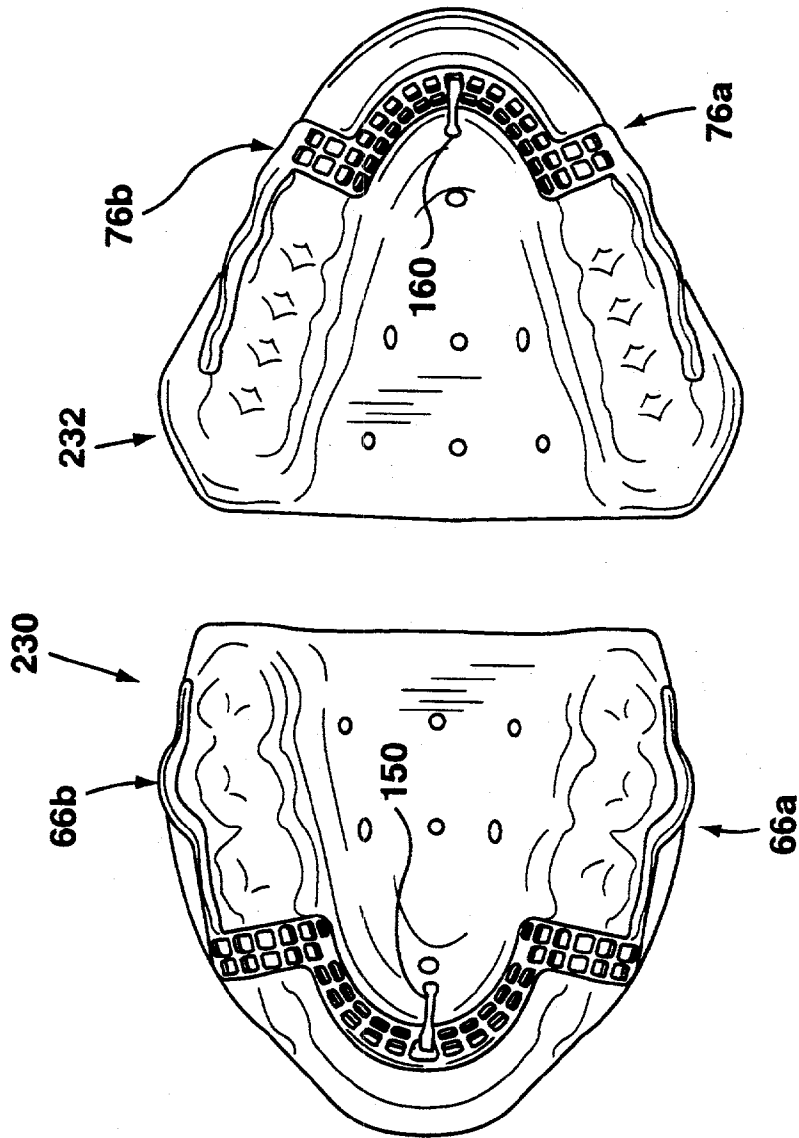

FIG. 9

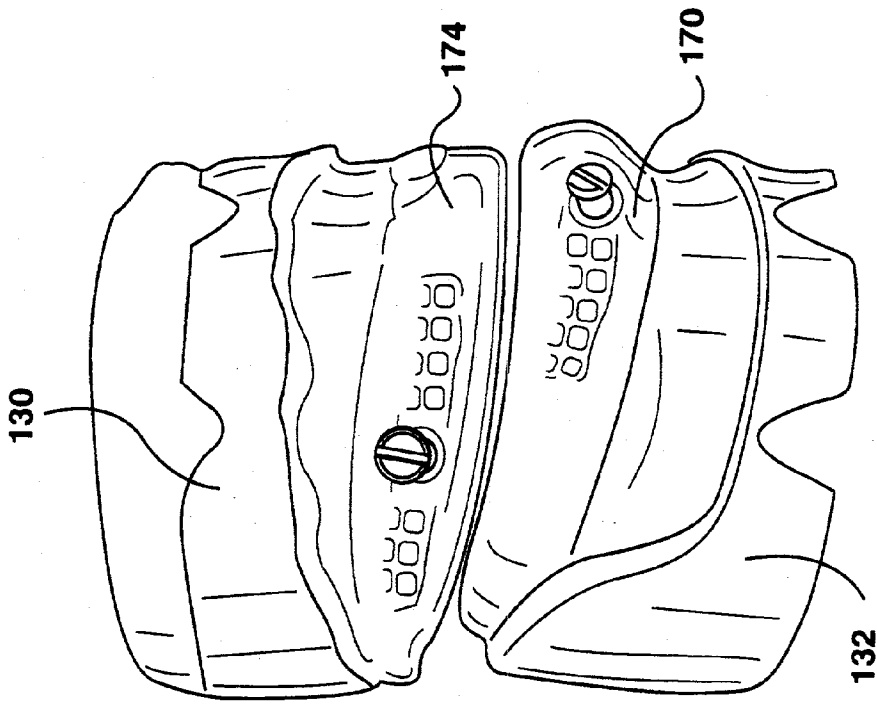

FIG. 11

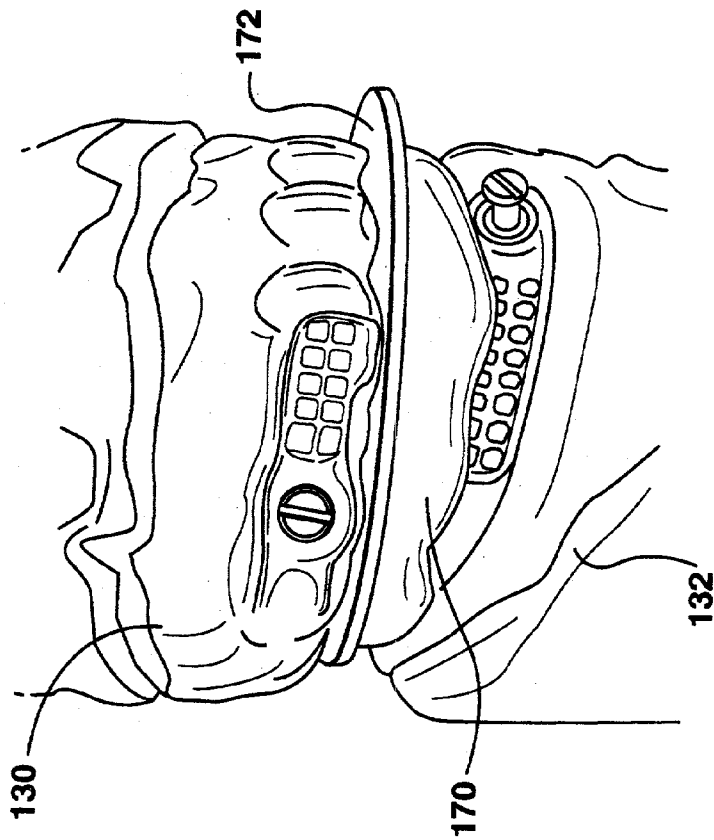

FIG. 10

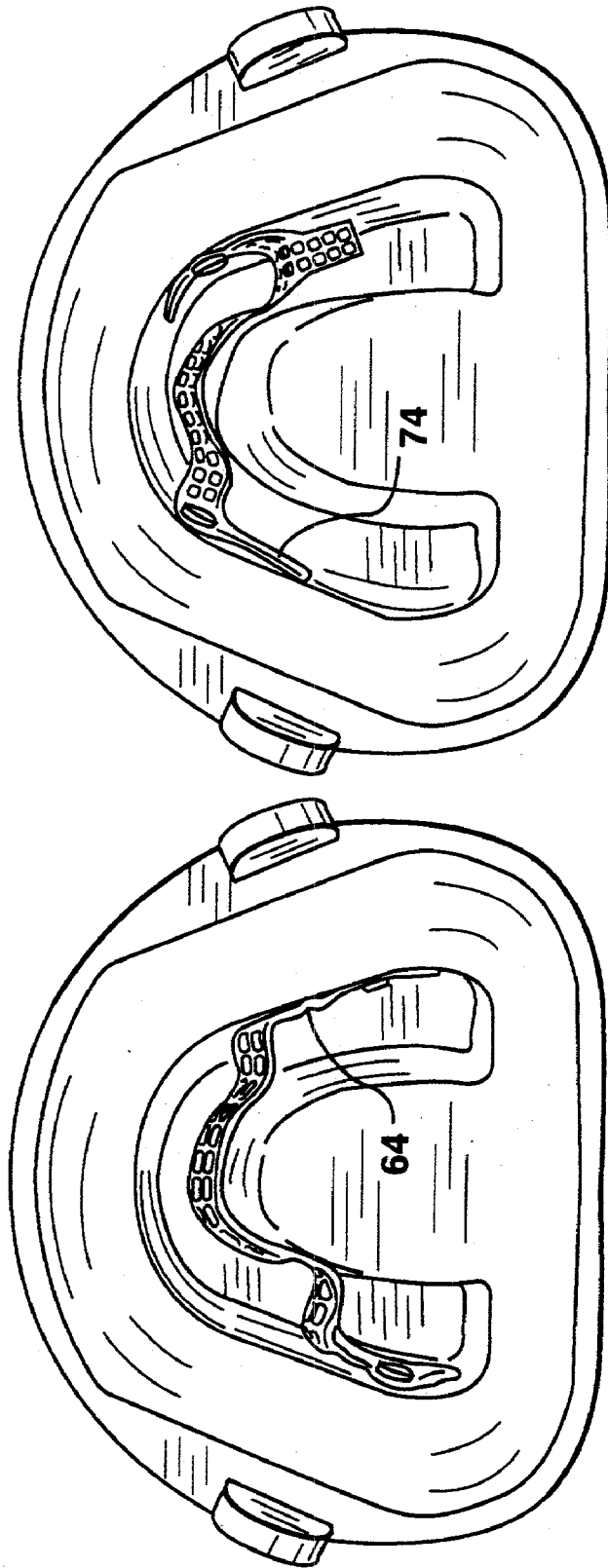

FIG. 12

ANTI-SNORING DEVICE AND METHOD OF MAKING SAME

BACKGROUND OF THE INVENTION

[0001] Snoring is a common affliction. It results from the muscles holding the mandible (lower jaw) relaxing during sleep such that the mandible moves posteriorly into the throat. This causes the throat to constrict increasing the speed and pressure of inhaled air which vibrates soft tissue in the back of the mouth. For some, who suffer from sleep apnea, the airway becomes completely blocked thereby interrupting breathing during sleep.

[0002] Snoring and sleep apnea can be avoided by preventing the mandible from moving posteriorly during sleep. A number of devices have been designed with this purpose in mind. For example, U.S. Pat. No. 5,499,633 to Fenton shows two bite forms which may be joined so that the user's mandible projects forwardly of its normal position in order to reduce snoring.

[0003] This invention seeks to provide an improved anti-snoring device and a method of manufacturing same.

SUMMARY OF INVENTION

[0004] An anti-snoring device has maxillary and mandibular bite forms with outwardly extending pivots which are mounted to the bite forms by frameworks which are at least partially embedded in the bite forms. This retains the pivots securely in place even in the face of extensive bruxing.

[0005] In constructing the device, a jig may be used for positioning the pivots.

[0006] The method of manufacturing the device involves casting the frameworks, such that each framework has a pair of pivot mounts, mounting pivots to the pivot mounts, and at least partially embedding the frameworks in the bite forms.

[0007] Accordingly, the present invention comprises an anti-snoring device, comprising: a maxillary bite form; a mandibular bite form; a first outwardly extending maxillary pivot posteriorly located on a first side of said maxillary bite form; a second outwardly extending maxillary pivot posteriorly located on a second side of said maxillary bite form; a first outwardly extending mandibular pivot anteriorly located on a first side of said mandibular bite form; a second outwardly extending mandibular pivot posteriorly located on a second side of said mandibular bite form; a first telescoping arm loosely pivoted to said first maxillary pivot and to said first mandibular pivot; a second telescoping arm loosely pivoted to said second maxillary pivot and to said second mandibular pivot; maxillary framework at least partially embedded in said maxillary bite form having a pivot mount for said first maxillary pivot and a pivot mount for said second maxillary pivot; mandibular framework at least partially embedded in said mandibular bite form having a pivot mount for said first mandibular pivot and a pivot mount for said second mandibular pivot.

[0008] According to another aspect of the present invention, there is provided a jig for positioning of pivots of an anti-snoring device, comprising: a medial portion having an inward face; a first end portion having a pivot receptor canted toward said inward face of said medial portion; a

second end portion opposite said first having a plurality of aligned pivot receptors along its length, said pivot receptors canted downwardly.

[0009] According to a further aspect of the invention, there is provided a method of manufacturing an anti-snoring device, comprising: casting a maxillary framework and a mandibular framework, such that each framework has a pair of pivot mounts; mounting pivots to said pivot mounts; embedding said maxillary framework at least partially in a maxillary bite form such that pivots extend outwardly from opposite sides of said maxillary bite form, embedding said mandibular framework at least partially in a mandibular bite form such that pivots extend outwardly from opposite sides of said mandibular bite form.

[0010] Other aspects and features of the invention will become apparent from the following description.

BRIEF DESCRIPTION OF THE DRAWINGS

[0011] In the figures which illustrate example embodiments of the invention,

[0012] FIG. 1 is a perspective view of a device made in accordance with this invention,

[0013] FIG. 2 is a plan view of the device of FIG. 1 with the bite forms separated,

[0014] FIG. 3 is a top and side view of a pivot in the device of FIG. 1,

[0015] FIGS. 4 and 5 are perspective views of jigs used in constructing the device of FIG. 1,

[0016] FIG. 6 is a perspective view of the jig of FIG. 4 shown in use,

[0017] FIG. 7 is a perspective view of master casts in an articulator showing the jig of FIG. 4 in use,

[0018] FIG. 8 is top and side views of a duplicating pivot used in the construction of the device of FIG. 1,

[0019] FIG. 9 is a top view of maxillary and mandibular framework fabricating casts with maxillary and mandibular frameworks of the device of FIG. 1,

[0020] FIG. 10 is a perspective view of the master casts of FIG. 7 with the frameworks of FIG. 9 and a twenty-degree bite plate,

[0021] FIG. 11 is a perspective view of the master casts of FIG. 7 with the frameworks of FIG. 9 and wax bodies, and

[0022] FIG. 12 is a top view of mould cavity halves with the frameworks of FIG. 9.

DETAILED DESCRIPTION

[0023] Turning to FIGS. 1 and 2, an anti-snoring device 20 has a maxillary bite form 22 and a mandibular bite form 24. Each bite form may be fabricated of acrylic and has a dentition receiving cavity 26 which reflects the dentition of the intended user of the device. The dentition receiving cavity 26 may be lined with a soft fabric.

[0024] Two outwardly extending maxillary pivots 30a, 30b are posteriorly located on opposite sides 32a, 32b of the maxillary bite form 22. The pivot center of each of these maxillary pivots 30a, 30b may be located between the

mesial of the first molar and the mesial of the second molar mirrored by the maxillary bite form 22. Two outwardly extending mandibular pivots 30c, 30d are anteriorly located on opposite sides 38a, 38b of the mandibular bite form 24. The pivot center of each of the mandibular pivots 30c, 30d may be located posteriorly of the distal edge of the cuspid mirrored by the mandibular bite form.

[0025] Referencing FIG. 3, each pivot 30 has an interiorly threaded cylindrical pivot portion 40 with a pivot axis P and an enlarged cylindrical base 42 with a notch 44. (Typically, the pivot is manufactured with a cylindrical base and the notch is cut out later.) Returning to FIGS. 1 and 2, a sleeve 50a terminates in an eyelet 52a which is pivotably mounted on maxillary pivot 30a. A screw 54a threaded to pivot 30a retains the eyelet on the pivot 30a. Similarly, eyelet 52b of sleeve 50b is pivotably mounted on pivot 30b and retained by a screw. A rod 60a terminates in an eyelet 62a which is pivotably mounted on mandibular pivot 30c. A screw threaded to pivot 30c retains the eyelet on the pivot 30c. Similarly, eyelet 62b of rod 60b is pivotably mounted on pivot 30d and retained by a screw. Each sleeve 50a, 50b telescopingly receives a respective rod 60a, 60b to form a telescoping arm 63a, 63b pivoted at either end to a maxillary pivot and to a mandibular pivot. The eyelets have a larger interior diameter than the outer diameter of the cylindrical pivot portion 40 of the pivots 30 so that pivotable connections are loose (i.e., they allow for some play).

[0026] A maxillary mesh framework 64, fabricated of metal, is at least partially embedded in the maxillary bite form 22. Framework 64 has pivot mounts 66a, 66b (FIG. 9) for maxillary pivots 30a, 30b. Each pivot mount is an opening through the mesh sized to accommodate the cylindrical pivot portion 40 of a pivot 30 but which is substantially smaller than the enlarged base 42 of the pivot. Similarly, a mandibular mesh framework 74 is at least partially embedded in the mandibular bite form 24 and has pivot mounts 76a, 76b (FIG. 9) for mandibular pivots 30c, 30d.

[0027] Maxillary mesh framework 64 has a first portion 68a embedded in the buccal face 86 of the maxillary bite form 22 at side 32a. This first portion has pivot mount 66a. Framework 64 also has a second portion 68b embedded in buccal face 86 of form 22 at side 32b; this second portion has pivot mount 66b. A medial portion 70 of framework 64 is embedded in a lingual face 82 of the maxillary bite form 22. A first bridge 72a extends across an occlusal face 88 of the maxillary bite form 22 and joins the first portion 68a with the medial portion 70. Similarly, a second bridge 72b extends across occlusal face 88 of the maxillary bite form and joins the second framework portion 68b with medial portion 70.

[0028] The first bridge 72a and the second bridge 72b are located at dentition mirrored by the maxillary bite form 22 which has a lower height than other dentition mirrored by the form. Typically, this means that the bridges are located somewhere between the distal of the 3's mirrored by the form or at the mesial of 6's mirrored by the form.

[0029] In a similar fashion, mandibular mesh framework 74 has a first portion 78a embedded in the buccal face 96 of the mandibular bite form 24 at side 38a. This first portion has pivot mount 76a. Framework 74 also has a second portion 78b embedded in buccal face 96 of form 24 at side 38b; this second portion has pivot mount 76b. A medial

portion 80 of framework 74 is embedded in a lingual face 92 of the mandibular bite form 24. A first bridge 82a extends across an occlusal face 98 of the mandibular bite form 24 and joins the first portion 78a with the medial portion 80. Similarly, a second bridge 82b extends across occlusal face 98 of the maxillary bite form and joins the second framework portion 78b with medial portion 80.

[0030] Again, the bridges 82a, 82b are located at dentition mirrored by the mandibular bite form 24 which has a lower height than other dentition mirrored by the form.

[0031] The occlusal face 88 of the maxillary bite form 22 has a central planar portion 89 which is in registration with a central planar portion 99 of the occlusal face 98 of the mandibular bite form 24. These planar portions 89, 99 meet when the device 20 is closed. Further, these planar portions parallel a bite plane of the dentition.

[0032] In operation, a user whose dentition is mirrored by the bite forms 22, 24 may insert the bite forms in his mouth and bite down to seat the bite forms on his dentition. The telescoping arms 63a, 63b allow the user to open and close his mouth. Further, the loose pivot connection between these arms 63a, 63b and pivots 30a to 30d allow the user some lateral freedom (to brux). However, when the user closes his mouth such that the two bite forms abut, the arms maintain the mandibular bite form 24, and hence the users mandible, in a position which juts forward of the user's maxilla. This avoids constriction of the user's throat and hence alleviates snoring and sleep apnea.

[0033] The positioning of pivots 30a, 30b between the first and second molars of the maxilla and the positioning of pivots 30c, 30d at the cuspids of the mandible assist in relieving stress on the temporal mandibular joint (TMJ) during bruxing. Further in this regard, the central planar portions 89, 99 of the occlusal faces 88, 98 of the bite forms 22, 24, which meet when the forms are closed and mirror the bite plane of the user, also relieve stress on the TMJ during bruxing.

[0034] The mesh frameworks 64, 74 with their pivot mounts 66a, 66b and 76a, 76b, respectively, provide an enduring mount for pivots 30a to 30d. More particularly, even in the face of extensive bruxing, the pivots 30a to 30d will not pull out of the metal mesh frameworks 64, 74 and the mesh frameworks, being embedded in a significant portion of the bite frames 22, 24, also will not pull out. Further, the medial portion of framework 74 acts to strengthen the medial portion of the mandibular bite form 24. This is beneficial since this portion of the bite form is subject to stress during bruxing which, absent the framework, could result in a stress fracture.

[0035] To manufacture the device 20 of FIG. 1, impressions are taken of a patient's dentition and maxillary and mandibular master casts 130, 132 (FIG. 7) are fabricated from these impressions. The master casts are then mounted to an articulator 134 (FIG. 7) which is adjusted so as to establish the proper closed position of the two master casts. As will be appreciated by those skilled in the art, this may be accomplished with a George gauge which allows the determination of the proper protruded position of the mandibular cast with respect to the maxillary cast and the minimum vertical spacing between the casts. Vent holes may then be drilled into these casts. A dual laminate material may

then be attached (with heat) to the dentition of the master casts such that the harder layer of the laminate is on the outside.

[0036] Next the pivots **30a** to **30d** are located on the master casts. With reference to FIGS. 4 to 6, to facilitate this, left and right jigs **102**, **104**, respectively, are used. Each jig has a medial portion **108** and two end portions **110**, **112**. End portion **110** has a single through bore **114** which acts as a pivot receptor while end portion **112** has a plurality of aligned through bores (pivot receptors) **116** along its length. End portion **110** is bent inwardly so that its pivot receptor **114** cants toward inward face **118** of medial portion **108** at an angle of about 15 degrees. End portion **112** is twisted with respect to the medial portion **108** such that pivot receptors **116** cant downwardly on the inward side **120** of the jig at an angle of about seven degrees. A handle **122** extends from the outward side **124** of the jig. The canting of the pivot receptors assist in ensuring that the jig will place the pivots at an angle which is mirrored by the dentition so that the inner surface of the pivots is substantially flush with the dentition.

[0037] Referencing FIG. 6, the pivot portion **40** of a pivot **30b** is pushed into receptor **114** of jig **102** from the inward side **120** of the jig and a screw is threaded into the pivot portion from the outward side **124** of the jig in order to secure the pivot **30b** to the jig. A pivot **30d** is pushed in to the receptor **116'** (FIG. 4) which is closest to the outer end of end portion **112** from the inward side of the jig and another screw is threaded to the pivot to secure it to the jig. Similarly, pivots **30a** and **30c** are secured to jig **104**.

[0038] Turning to FIG. 7, the left jig **102** may then used to locate the pivots **30b**, **30d**, as follows. First pivot **30b** in receptor **114** (FIG. 6) is located by placing its center P (FIG. 3) interproximal to the first and second molars on the left side of the maxillary cast **130**. Preferably, the center of the pivot is not located posteriorly of the mesial of the second molar to avoid the pivot impinging on the muscles of a user of a device **20** (FIG. 1) and causing discomfort. Ideally, the pivot should be centered between the occlusal cusps and the gingival margin of the molars. However, where due to a short crown, the pivot, so located, would extend past the occlusal edge of the molars, the pivot should be moved toward the tissue even if this means extending past the gingival margin. If this is not done, it may weaken device **20** (FIG. 1).

[0039] Next, while holding pivot **30b** in its correct location, the jig **102** is manipulated to locate pivot **30d** appropriately. Ideally, pivot **30d** is located in the center of the dentition between the occlusal/incisal edge and the gingival margin. However, again, the pivot should not extend past the occlusal/incisal edge and may, if necessary, be located partially on the tissue surface. Preferably, the center of the pivot **30d** is not located anteriorly of the distal edge of the lower cuspid as this may cause discomfort to the lower lip and may also reduce the amount of lateral movement of the device **20** (FIG. 1). If the jig does not so locate the pivot, pivot **30d** should be placed in another of pivot receptors **116** (FIG. 4) so that the pivot may be properly located. The pivots may then be secured in position using hot wax. This same procedure may then be used with jig **104** to locate pivots **30a** and **30c**.

[0040] The pivots are ideally located at the same position at either side of the casts in order to maximize the lateral

movement which will be permitted by the device **20** (FIG. 1) when bruxing thus helping to reduce stress on the TMJ.

[0041] With the pivots correctly located and secured to the casts, the screws retaining them to the jigs may be removed and the jigs taken away. The wax around the base of the pivots may then be trimmed and the pivots then pulled off leaving an indentation in the remaining wax marking their proper locations. The casts are then removed from the articulator.

[0042] Next duplicating pivots **140** (FIG. 8) are placed into the wax indentations and secured in place. A mould is then taken of each cast **130**, **132**; framework fabrication casts **230**, **232** (FIG. 9) are made from these moulds. Frameworks **64**, **74** are then cast from molten metal using these fabrication casts and conventional casting processes. The castings are designed so that the frameworks meet the following criteria. The first and second portions **68a**, **68b** of the maxillary framework **64** ideally start at the distal of the 7's and continue along the buccal face of the posterior teeth until bridges **72a**, **72b**. The medial portion **70** of the framework extends along the lingual face of the teeth between the bridges.

[0043] The first and second portions **78a**, **78b** of the mandibular framework ideally start at the mesial of the 3's and continue past the bridge **82a**, **82b** to the distal of the 6's.

[0044] These bridges should be located where they will not interfere with the occlusal plane, thus, in an area where the dentition is lower in height than the rest of the dentition, as aforementioned. A thin protuberance **150**, **160** on each framework **64**, **74** extends posteriorly directly behind the centrals.

[0045] After casting the frameworks, they are removed from the fabricating casts and pivots **30** are inserted into the pivot mounts of the frameworks. The duplicating pivots are removed from the master casts **130**, **132** (FIG. 7) and the frameworks, carrying the pivots **30**, are then positioned on the casts **130**, **132**. The casts are then re-mounted to the articulator **134** (FIG. 7). With the articulator in its closed position, the gap (G—not shown) is measured between the upper and lower incisal edges of the dentition at the anterior midline and the closing limit of the articulator to establish this gap is noted. Referencing FIG. 10, a warm (and hence pliable) wax body **170** is then applied over the dentition of the mandibular cast **132**. This wax body is manipulated so as not to cover the pivots **30c**, **30d** (FIG. 2) or the protuberance **160** (FIG. 9) of framework **74** and to at least partially embed framework **74**. A twenty degree bite plate **172** is held evenly against the dentition of the maxillary cast and the articulator is closed until the plate makes an even contact with the wax body and just touches any part of the dentition of the mandibular cast. The anterior midline of the bite plate is aligned with the midline of the anterior teeth. Further, the posterior portion of the bite plate is symmetrically positioned with respect to the posterior teeth. The bite plate is then secured to the wax body **170** (with a warm wax instrument) as seen in FIG. 10.

[0046] The closing limit of the articulator **134** (FIG. 7) is then adjusted to establish a gap (G/2) between the lower incisal edges of the dentition of the maxillary cast **130** at the anterior midline and the twenty degree bite plate **172**. This gap is equal to one half the gap (G) previously measured between the upper and lower incisal edges of the dentition at the anterior midline.

[0047] The articulator is then opened and a wax body **174** (**FIG. 11**) is applied over the dentition of the maxillary cast. Again, the wax body is manipulated so as not to cover the pivots **30, 30b** (**FIG. 2**) or protuberance **150** (**FIG. 9**) and at least partially embed framework **64**. The articulator is again moved toward a closed position while laterally reciprocating the casts in order that the twenty-degree bite plate **172** smooths and angles an occlusal surface of the maxillary wax body. Once the articulator has bottomed out on the closing limit, the shaping of the maxillary wax body is complete and the twenty-degree bite plate may then be removed. The closing limit of the articulator is then re-adjusted to the position that reflected the gap (G) between the upper and lower incisal edges of the dentition of the casts at the anterior midline. Then, with the upper wax body cooled and hard and the lower wax body slightly warm and pliable, the articulator is again moved toward a closed position while the casts are laterally reciprocated. This results in the maxillary wax body smoothing and angling the mandibular wax body. This stage of the procedure is illustrated in **FIG. 11**.

[0048] The master casts **130, 132** are then removed from the articulator and a mould forming material (such as plaster) is applied around each wax body **170, 174** such that each protuberance **150, 160** (**FIG. 9**) and pivots **30a** to **30d** are embedded in the mould forming material. The mould forming material is then allowed to set. Subsequently, heat is applied to melt the wax so that the wax can be removed. This leaves mould forming cavities. **FIG. 12** illustrates one half of each of these mould forming cavities with the maxillary and mandibular casts removed for illustration purposes. The embedding of the protuberances and pivots is apparent from **FIG. 12**. Each mould cavity may then be filled with a curable material, such as acrylic. The embedded protuberances and pivots anchor the frameworks **64, 74** in proper position during this process. After the curable material has hardened, it forms the maxillary and mandibular bite forms **22, 24** seen in **FIG. 1** with the at least partially embedded frameworks.

[0049] The maxillary and mandibular casts may then be removed, leaving behind the dual laminate which is now firmly embedded on the occlusal surface of the bite forms with the soft layer of the laminate exposed. The hardened moulding material may then be broken away from the bite forms. Next the rods and sleeves may be attached to appropriate pivots with screws and the device **20** described in conjunction with **FIG. 1** completed. In this regard, the notch **44** (**FIG. 3**) in the embedded base **42** of the pivots prevents the pivots from turning while the screws are turned.

[0050] Modifications will be apparent and, therefore, the invention is defined in the claims.

What is claimed is:

1. An anti-snoring device, comprising:

- a maxillary bite form;
- a mandibular bite form;
- a first outwardly extending maxillary pivot posteriorly located on a first side of said maxillary bite form;
- a second outwardly extending maxillary pivot posteriorly located on a second side of said maxillary bite form;
- a first outwardly extending mandibular pivot anteriorly located on a first side of said mandibular bite form;

a second outwardly extending mandibular pivot posteriorly located on a second side of said mandibular bite form;

a first telescoping arm loosely pivoted to said first maxillary pivot and to said first mandibular pivot;

a second telescoping arm loosely pivoted to said second maxillary pivot and to said second mandibular pivot;

maxillary framework at least partially embedded in said maxillary bite form having a pivot mount for said first maxillary pivot and a pivot mount for said second maxillary pivot;

mandibular framework at least partially embedded in said mandibular bite form having a pivot mount for said first mandibular pivot and a pivot mount for said second mandibular pivot.

2. The anti-snoring device of claim 1 wherein said maxillary framework has a first portion extending along said first side, a second portion extending along said second side, and a medial portion joining said first portion and said second portion.

3. The anti-snoring device of claim 2 wherein said first portion and said second portion are embedded in a buccal face of said maxillary bite form and said medial portion is embedded in a lingual face of said maxillary bite form and wherein said maxillary framework has a first bridge extending across an occlusal face of said maxillary bite form joining said first portion with said medial portion and a second bridge extending across said occlusal face of said maxillary bite form joining said second portion with said medial portion.

4. The anti-snoring device of claim 3 wherein said first bridge and said second bridge are located at dentition mirrored by said maxillary bite form which has a lower height than other dentition mirrored by said maxillary bite form.

5. The anti-snoring device of claim 3 wherein said first bridge and said second bridge are located between a distal of 3's and a mesial of 6's mirrored by said maxillary bite form.

6. The anti-snoring device of claim 3 wherein each said pivot has a cylindrical pivot portion and an integrally formed enlarged base portion.

7. The anti-snoring device of claim 6 wherein said enlarged base portion is configured as a notched cylinder.

8. The anti-snoring device of claim 1 wherein a pivot center of each of said first and second maxillary pivots is located at a point between a distal of a first molar and a mesial of a second molar mirrored by said maxillary bite form.

9. The anti-snoring device of claim 8 wherein a pivot center of each of said first and second mandibular pivots is located posteriorly of a distal edge of a cusp id mirrored by said mandibular bite form whereby stress on a temporal mandibular joint is reduced during bruxing.

10. The anti-snoring device of claim 1 wherein an occlusal face of said maxillary bite form has a central planar portion which mirrors a bite plane of dentition reflected by said maxillary bite form and said mandibular bite form and wherein an occlusal face of said mandibular bite form has a central portion which mirrors said bite plane.

11. A jig for positioning of pivots of an anti-snoring device, comprising:

- a medial portion having an inward face;

a first end portion having a pivot receptor canted toward said inward face of said medial portion;

a second end portion opposite said first having a plurality of aligned pivot receptors along its length, said pivot receptors canted downwardly.

12. The jig of claim 11 further comprising a handle extending from an outward face of said medial portion opposite said inward face.

13. The jig of claim 11 wherein said inward cant of said first end portion pivot receptor is about fifteen degrees and wherein said downward cant of said plurality of aligned pivot receptors is about seven degrees.

14. A method of manufacturing an anti-snoring device, comprising:

casting a maxillary framework and a mandibular framework, such that each framework has a pair of pivot mounts;

mounting pivots to said pivot mounts;

embedding said maxillary framework at least partially in a maxillary bite form such that pivots extend outwardly from opposite sides of said maxillary bite form,

embedding said mandibular framework at least partially in a mandibular bite form such that pivots extend outwardly from opposite sides of said mandibular bite form.

15. The method of claim 14 wherein said casting is also such that each framework has a protuberance, said maxillary framework protuberance anchoring said maxillary framework during said embedding said maxillary framework and said mandibular framework protuberance anchoring said mandibular framework during said embedding said mandibular framework.

16. The method of claim 15 further comprising:

mounting said maxillary framework to a maxillary cast;

mounting said mandibular framework to a mandibular cast;

mounting said maxillary cast and said mandibular cast to an articulator;

attaching a twenty degree bite plate to one of said mandibular cast and said maxillary cast;

applying a first wax body to another of said mandibular cast and said maxillary cast;

partially closing said articulator and laterally reciprocating said casts to smooth and angle a surface of said first wax body with said twenty degree bite plate.

17. The method of claim 16 further comprising:

removing said twenty degree bite plate;

applying a second wax body to said one of said mandibular cast and said maxillary cast;

partially closing said articulator and laterally reciprocating said casts to smooth and angle a surface of said second wax body with said first wax body.

18. The method of claim 17 wherein said applying said first wax body and said applying a second wax body leaves said protuberance of each said framework exposed and further comprising:

removing said maxillary cast and said mandibular cast from said articulator;

applying a mould forming material around each said wax body such that each said protuberance of each said framework is embedded in said mould forming material;

removing each said wax body from said mould forming material to leave mould cavities;

filling each mould cavity with a curable material and hardening said curable material to form said maxillary bite form with said embedded maxillary framework and said mandibular bite form with said embedded mandibular framework.

19. The method of claim 14 further comprising:

prior to casting said maxillary framework and said mandibular framework, attaching a first maxillary pivot and a first mandibular pivot to a jig;

locating said first maxillary pivot on said maxillary cast and said first mandibular pivot on said mandibular cast with said jig; and

marking a location of said first maxillary pivot on said maxillary cast and said first mandibular pivot on said mandibular cast.

* * * * *