

(19) World Intellectual Property Organization
International Bureau



(43) International Publication Date
18 December 2003 (18.12.2003)

PCT

(10) International Publication Number
WO 03/103752 A1

(51) International Patent Classification⁷: A61M 5/30

(21) International Application Number: PCT/US03/16446

(22) International Filing Date: 22 May 2003 (22.05.2003)

(25) Filing Language: English

(26) Publication Language: English

(30) Priority Data:
10/164,920 4 June 2002 (04.06.2002) US

(71) Applicant (for all designated States except US): **BIOJECT INC.** [US/US]; 7620 SW Bridgeport Rd., Portland, OR 97224 (US).

(72) Inventors; and

(75) Inventors/Applicants (for US only): **WILLIAMSON, Dan** [US/US]; 23785 SE Brittany Lane, Sherwood, OR 97410 (US). **LANDAU, Sergio** [US/US]; 49 South Peak, Laguna Nigel, CA 92677 (US). **MARSHALL, John R.** [US/US]; 16693_NW Meadowgrass Court, Beaverton, OR 97006 (US).

(74) Agents: **HEUSER, Peter E.** et al.; Kolisch Hartwell, P.C., 520 SW Yamhill St., Suite 200, Portland, OR 97204 (US).

(81) Designated States (national): AE, AG, AL, AM, AT, AU, AZ, BA, BB, BG, BR, BY, BZ, CA, CH, CN, CO, CR, CU, CZ, DE, DK, DM, DZ, EC, EE, ES, FI, GB, GD, GE, GH, GM, HR, HU, ID, IL, IN, IS, JP, KE, KG, KP, KR, KZ, LC, LK, LR, LS, LT, LU, LV, MA, MD, MG, MK, MN, MW, MX, MZ, NI, NO, NZ, OM, PH, PL, PT, RO, RU, SC, SD, SE, SG, SK, SL, TJ, TM, TN, TR, TT, TZ, UA, UG, US, UZ, VC, VN, YU, ZA, ZM, ZW.

(84) Designated States (regional): ARIPO patent (GH, GM, KE, LS, MW, MZ, SD, SL, SZ, TZ, UG, ZM, ZW), Eurasian patent (AM, AZ, BY, KG, KZ, MD, RU, TJ, TM), European patent (AT, BE, BG, CH, CY, CZ, DE, DK, EE, ES, FI, FR, GB, GR, HU, IE, IT, LU, MC, NL, PT, RO, SE, SI, SK, TR), OAPI patent (BF, BJ, CF, CG, CI, CM, GA, GN, GQ, GW, ML, MR, NE, SN, TD, TG).

Published:

- with international search report
- before the expiration of the time limit for amending the claims and to be republished in the event of receipt of amendments

For two-letter codes and other abbreviations, refer to the "Guidance Notes on Codes and Abbreviations" appearing at the beginning of each regular issue of the PCT Gazette.

(54) Title: NEEDLE-FREE INJECTION SYSTEM

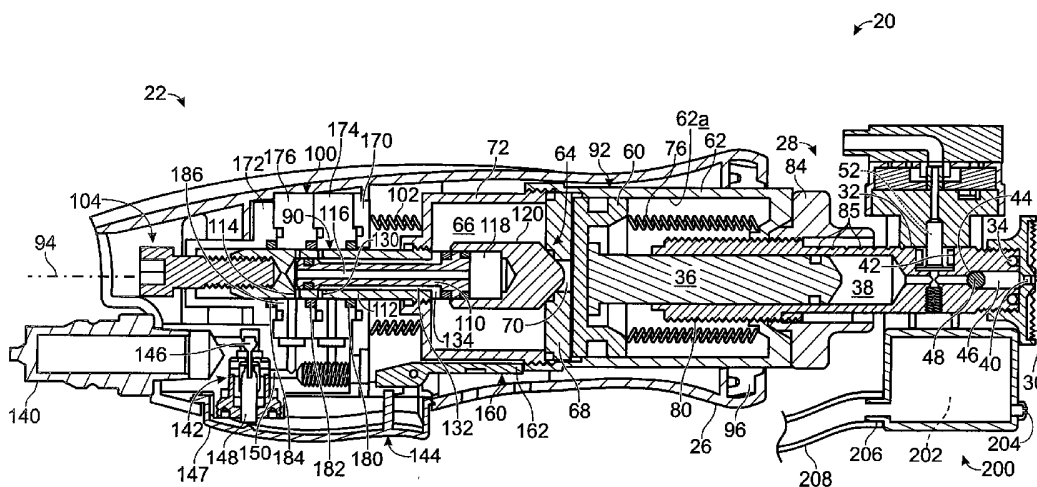

(57) Abstract: A needle-free injection device (22) includes a user-grippable housing (26) and a syringe assembly (28) movably secured to the housing (26). The syringe assembly (28) is configured to expel injectable fluid out of a nozzle (30) upon application of pressurized gas to the syringe assembly (28). The injection device (22) also includes a pressurized gas delivery mechanism (64) disposed within the housing (26) and configured to selectively apply pressurized gas to the syringe assembly (28). The pressurized gas delivery mechanism (64) is at least partly actuated by pressing the nozzle (30) onto an injection site so that the syringe assembly (28) moves relative to the housing (26).



WO 03/103752 A1

NEEDLE-FREE INJECTION SYSTEM

Field of the Invention

The invention relates to needle-free injection systems that employ pressurized gas to deliver injections of injectable fluid.

5 Background of the Invention

Needle-free injection systems provide an alternative to standard fluid delivery systems, which typically use a needle adapted to penetrate the outer surface of a target. Typically, needle-free injection systems are designed to eject the fluid from a fluid chamber with sufficient pressure to allow the fluid to penetrate the target to the
10 desired degree. For example, common applications for needle-free injection systems include delivering intradermal, subcutaneous and intramuscular injections into or through a recipient's skin. For each of these applications, the fluid must be ejected from the system with sufficient pressure to allow the fluid to penetrate the tough exterior dermal layers of the recipient's skin.

15 Summary of the Invention

The invention provides an improved needle-free injection device. The injection device includes a user-grippable housing and a syringe assembly movably secured to the housing. The syringe assembly is configured to expel injectable fluid out of a nozzle upon application of pressurized gas to the syringe assembly. The injection
20 device also includes a pressurized gas delivery mechanism disposed within the housing and configured to selectively apply pressurized gas to the syringe assembly. The pressurized gas delivery mechanism is at least partly actuated by pressing the nozzle onto an injection site so that the syringe assembly moves relative to the housing.

25

Brief Description of the Drawings

Fig. 1 is a sectional side elevation view of a needle-free injection system according to the invention, and depicts the system in a primed position.

Fig. 2 is a sectional side elevation view of the system of Fig. 1 that depicts the
30 system in a charged position.

Fig. 3 is a sectional side elevation view of the system of Fig. 1 that depicts the system after it has been fired.

Fig. 4 is an exploded view of the system of Fig. 1.

Fig. 5 is an isometric exploded view showing structures that may be used to connect a fluid supply to the injection device depicted in Figs. 1-4.

Fig. 6 is an isometric view of a fluid supply adapter that is also shown in Fig. 5.

Fig. 7 is a bottom view of the fluid supply adapter shown in Figs. 5 and 6.

Fig. 8 is a top view of a locking ring that is also shown in Fig. 5.

Figs. 9A, 9B and 9C are top views of a rotatable key member that is also shown in Fig. 5, and show the rotatable key member in three different rotational positions relative to the injection device of Figs. 1-4.

Fig. 10 is a top view of a base member that is also shown in Fig. 5.

Detailed Description of the Preferred Embodiment

Construction of a Preferred Embodiment

Fig. 1 depicts a needle-free injection system 20 according to the invention, including an injection device 22. Fig. 1 shows injection device 22 in a first position, which will be referred to as the "primed" or "priming" position. Typically, the device is also placed in the position shown in Fig. 1 for storage and/or shipping. Fig. 2 depicts device 22 in a position which will be referred to as the "charged" or "charging" position; Fig. 3 depicts device 22 in a position which will be referred to as the "fired" or "firing" position. Fig. 4 is an exploded view depicting various components that may be used to construct injection device 22.

As will be explained in more detail below, injection device 22 is configured to inject a dose of a drug or other fluid into a subject animal. This is accomplished by using pressurized gas to expel fluid from the injection device. The pressurized gas may be supplied from a tank, cartridge or other source, and typically is delivered through device 22 and vented via operation of various valve structures. System 20 may include a fluid supply 24 that may be coupled with injection device 22 in order

to supply the injection device with fluid, such as drugs, vaccines or other injectable fluids.

As shown, injection device 22 may include an outer housing 26, which typically is adapted to be comfortably held in a user's hand. The depicted housing is formed from injection-molded plastic, though various other materials and fabrication methods may be employed as desired.

Injection device 22 typically includes a fluid expulsion mechanism, such as syringe assembly 28, that is configured to draw in and forcibly expel drugs or other fluids. As shown in the figures, syringe assembly 28 may be disposed at least partially within housing 26 toward a forward end of the housing. Syringe assembly 28 includes a nozzle 30, which is affixed to an end of a fluid cylinder 32 and sealed thereon with an o-ring 34. A plunger 36 is slidably disposed within fluid cylinder 32, thereby defining a variable-volume fluid reservoir 38. When plunger 36 is advanced (i.e., moved to the right in Figs. 1-3), fluid is expelled out of fluid reservoir 38 through a discharge outlet 40 provided in nozzle 30. Retraction of plunger 36 (i.e., moving the plunger to the left in Figs. 1-3) draws fluid into fluid reservoir 38 through inlet 42, which typically is coupled with fluid supply 24. It should be appreciated that syringe assembly 28 is presented as an illustrative example only, and that other variable-volume devices may be employed. For example, a squeezable bulb or elastomeric bladder may be used to expel fluid from injection device 22.

In the depicted syringe assembly, outlet 40 and inlet 42 typically are provided with check valves to prevent backflow. Various types of valves may be used, though ball-type check valves have proved useful in the depicted embodiment. Specifically, as indicated in the figures, an outlet check ball 44 is disposed within an outlet check ball chamber 46. Outlet check ball 44 is held against a valve seat 48 as plunger 36 is retracted, to prevent fluid or contaminants from being drawn into fluid reservoir 38 through discharge outlet 40. A spring (not shown) may also be provided to urge the check ball to the left into the closed position. As plunger 36 advances, check ball 44 moves forward, away from engagement with seat 48, allowing fluid to pass around

the check ball and out of nozzle 30 through outlet 40. Inlet 42 may also include a similar ball-type check valve 52, including a check ball (not shown) urged upward into a closed position against a valve seat. When plunger 36 retracts, check valve 52 opens, allowing fluid from fluid supply 24 to be drawn through the check ball valve into fluid reservoir 38.

As indicated, a piston 60 may be secured to plunger 36. In the depicted embodiment, piston 60 is slidably disposed within a piston cylinder 62, and creates a substantially sealed interface with an interior wall 62a of the piston cylinder. As will be explained in more detail below, when a poppet valve 64 opens, as shown in Fig. 3, pressurized gas from a gas reservoir 66 is allowed to escape past a gas bulkhead 68 through a bulkhead opening 70. Gas reservoir 66 is contained within a gas cylinder 72, which is fixedly secured relative to bulkhead 68 and piston cylinder 62. Upon the opening of poppet valve 64, the pressurized gas exerts upon operative surface 60a of piston 60, causing piston 60 and plunger 36 to advance forward and expel fluid from syringe assembly 28 through discharge outlet 40. The area between bulkhead 68 and piston 60 created by the advancement of piston 60 will be referred to as piston chamber 74 (Fig. 3). As indicated, a return spring 76 may be provided to urge piston 60 back toward bulkhead 68 upon venting of pressurized gas within piston chamber 74 and gas reservoir 66.

Syringe assembly 28 may be configured with an adjustment capability to allow variation of the maximum amount of fluid that may be drawn into and expelled from fluid reservoir 38. Specifically, as indicated, the outer circumference of fluid cylinder 32 may include threads 80 configured to interface with corresponding threads on piston cylinder 62. Rotation of the fluid cylinder then varies the plunger's permitted range of motion, by adjusting the maximum amount by which plunger 36 may be withdrawn from fluid cylinder 32 before being blocked by bulkhead 68. This adjusts the maximum volume of fluid reservoir 38. A locking nut 84 may also be provided to retain fluid cylinder 32 in place relative to piston cylinder 62 once a desired volume has been selected. Indicia 85 may be provided on the outer surface

of the fluid cylinder 32, or in another suitable location, to indicate the selected volume and/or the relative position of fluid cylinder 32 and piston cylinder 62.

As indicated above, piston cylinder 62 typically is fixedly secured to gas bulkhead 68 and gas cylinder 72. Toward the rear half of housing 26, a slidable valve structure 90 is fixedly secured to gas cylinder 72. Piston cylinder 62, gas cylinder 72 and slidable valve structure 90 collectively form a reciprocating structure 92 which moves back and forth relative to housing 26 along axis 94. Syringe assembly 28 is secured to the forward end of reciprocating structure 92, and thus also moves relative to housing 26. The forward end of reciprocating structure 92 is held within an aperture in housing 26, such that at least part of syringe assembly 28 sticks out of the forward end of housing 26. A wiper seal 96 may be provided within the aperture to contact the reciprocating structure (e.g., the outer surface of piston cylinder 62). Toward the rear of reciprocating structure 92, slidable valve structure 90 is slidably supported within a valve body 100 that is fixedly secured within housing 26.

During operation, reciprocating structure 92 is progressively pushed into housing 26 from the position shown in Fig. 1, to the position shown in Fig. 3. Normally, this occurs as a result of pressing nozzle 30 against an injection site while manually gripping housing 26. Spring 102 is compressed as reciprocating structure 92 moves in a rearward direction relative to housing 26. Upon removal of the compressing force, spring 102 urges reciprocating structure 92 back toward the position shown in Fig. 1.

An adjustment bolt 104 or like device may be provided to adjust the degree to which reciprocating structure 92 may be pushed into housing 26. Specifically, as seen at the rear or left end of Fig. 3, the head of bolt 104 abuts the rear portion of the interior of housing 26 to prevent further rearward movement of reciprocating structure 92 relative to housing 26. Rotation of bolt 104 thus adjusts the available range of rearward travel of reciprocating structure 92.

As depicted, slidable valve structure 90 may include an inner valve sleeve 110 and an outer valve sleeve 112. In the depicted exemplary embodiment, outer valve

sleeve 112 includes a first set of holes 114 which fluidly communicate with a bore passage 116 defined through the center of inner valve sleeve 110. Bore passage 116 fluidly couples with a poppet reservoir 118 defined in part by poppet 120. In the depicted embodiment, poppet 120 is slidably movable back and forth on the end of
5 slidably valve structure 90. When poppet 120 is in its forward-most position, as shown in Figs. 1 and 2, poppet 120 seats into a valve seat in bulkhead 68, thus sealing off gas reservoir 66 from piston chamber 74. Fore-and-aft movement of poppet 120 typically is controlled by gas pressure existing in poppet reservoir 118 and gas reservoir 66.

10 Outer valve sleeve 112 may include another set of holes 130, which fluidly communicate with a cylindrical passage 132. As indicated, passage 132 may be defined between the inner and outer valve sleeves. Cylindrical passage 132 fluidly couples with gas reservoir 66 via holes 134.

A gas fitting 140 may be provided into housing 26, to enable the injection
15 device to be supplied with compressed air or some other pressurized gas via a gas hose (not shown). The delivery of pressurized gas through the device typically is controlled via a supply valve assembly 142, which is actuated via operation of a trigger 144. As shown, supply valve assembly 142 may include a valve 146 biased into a closed position by a spring (not shown), a supply valve plunger 148 secured to
20 supply valve 146, and a supply conduit 150 through which pressurized gas is provided upon opening of the valve.

Trigger 144 is pivotally movable relative to housing 26 via a hinge 147 provided toward its rear end. Pushing the forward end of trigger 144 inward (or upward as depicted) causes valve plunger 148 to move upward. Upward movement
25 of valve plunger 148 moves supply valve 146 upward into an open position, allowing pressurized gas to pass beyond supply valve 146 and be delivered to other parts of device 22 via a supply conduit 150.

Trigger 144 may also be used to operate a locking mechanism 160, which, when in the locked state shown in Fig. 1, prevents reciprocating structure 92 from
30 being pushed into housing 26. Locking mechanism 160 includes a latch 162

pivotaly connected within housing 26 and biased into the locking position by a spring (not shown). In addition to opening supply valve 146, pushing trigger 144 upward rotates latch 162 into an unlocked position, allowing reciprocating structure 92 to be moved rearward from the position shown in Fig. 1.

5 Valve body 100 includes a forward section 170, a rear section 172, and two intermediate sections 174 and 176. A spring 102 extends between and urges against forward section 170 and the rear end of gas cylinder 72. Three U-cup seals 180, 182 and 184 are provided between the pieces of the valve body. The area of intermediate section 176 between seals 182 and 184 provides a supply chamber 186 that is fluidly
10 coupled with supply conduit 150 of supply valve assembly 142. The area of rear section 172 to the rear of seal 184 vents to atmosphere, as does the area of intermediate section 174 forward of seal 180.

Accordingly, it will be appreciated that moving slidable valve structure 90 backward and forward relative to valve body 100 (e.g., by pushing reciprocating
15 structure 92 into housing 26) controls pressurization and venting of the various passages in slidable valve structure 90. Referring to Fig. 3, for example, valve structure 90 is positioned so that holes 114 in outer valve sleeve 112 are aligned slightly to the rear of seal 184, allowing bore passage 116 and poppet reservoir 118 to vent to atmosphere. In Fig. 1, holes 130 are aligned slightly to the front of seal
20 180, allowing cylindrical passage 132 and gas reservoir 66 to vent to atmosphere. In Figs. 1-3, holes 114 and/or holes 130 are at times aligned with supply chamber 186, such that the respective passages and reservoirs are equalized in pressure relative to the supply chamber. Accordingly, in such a state of alignment, opening supply valve
146 would pressurize the respective passages/reservoirs.

25 As seen in Fig. 1, injection device 22 may also include a dye marker 200. Dye marker 200 includes a dye reservoir 202 and a dye outlet 204. A pressure inlet 206 is coupled with a pressure source via a hose 208. Dye marker 200 is configured to apply a metered amount of marking dye to an injection site upon application of air pressure through hose 208. Typically, the pressure source is provided by the residual
30 air pressure in gas reservoir 66 and piston chamber 74 as those areas are vented.

Specifically, hose 208 may be coupled to an exhaust port in housing 26 to fluidly couple dye marker 200 with venting passages within injection device 22.

Operation of the Depicted Injection Device

The operation of injection device 22 will now be described with reference to Figs. 1-3. Injection device 22 is prepared for initial use by coupling a hose (not shown) from a compressed air tank or other supply of pressurized gas to fitting 140. Injection device 22 is then primed by firing the device one or more times, in the manner to be described below, in order to expel air from fluid reservoir 38 and draw a full metered dose of injectable fluid into the fluid reservoir. Operation of the injection device will be described assuming the device has been fully primed and is in the position shown in Fig. 1.

First, the operator grips outer housing 26, and presses trigger 144 inward, which releases locking mechanism 160 to allow reciprocating structure 92 to be pushed into housing 26. Depressing trigger 144 also opens supply valve 146, which causes pressurized gas to flow through supply conduit 150 into supply chamber 186. In the priming position shown in Fig. 1, holes 114 are aligned with supply chamber 186. Bore passage 116 is thus pressurized by the opening of supply valve 146, which causes poppet 120 to move forward and close the poppet valve, sealing off bulkhead 68 between gas reservoir 66 and piston chamber 74.

Trigger 144 is held depressed while housing 26 is pressed by the operator against the injection site, causing reciprocating structure 92 to be pushed into housing 26, such that device 22 moves from the primed position shown in Fig. 1 to the charged position shown in Fig. 2. In Fig. 2, holes 114 are still aligned with supply chamber 186, but the slidable valve assembly has moved far enough rearward so that holes 130 are now also aligned with supply chamber 186. Thus, gas reservoir 66 is pressurized (charged) via holes 130 and cylindrical passage 132. Poppet reservoir 118 remains pressurized in Fig. 2, such that poppet valve 64 is held closed and no gas escapes into piston chamber 74. Plunger 36 thus remains in its fully withdrawn position. Though Fig. 2 shows trigger 144 un-depressed, it should be

appreciated that the trigger is held depressed long enough to allow air delivered through supply valve 146 to charge gas reservoir 66.

As the operator continues to push housing 26 against the injection site, reciprocating structure 92 is pushed further into the housing. At some point, slidable valve structure 90 slides far enough rearward so that holes 114 pass beyond U-cup seal 184, as seen in Fig. 3, which shows the injection device in the firing position. When holes 114 pass beyond seal 184, poppet reservoir 118 is allowed to vent to atmosphere through bore passage 116. At this point, there is a high pressure differential between gas reservoir 66 and atmosphere (e.g., 800 p.s.i. or greater), which causes poppet 120 to move rapidly away from bulkhead 68 and into its rearmost position.

This opens poppet valve 64, which causes the pressurized gas that was contained within gas reservoir 66 to act upon operative surface 60a of piston 60, causing injectable fluid to be rapidly expelled from fluid reservoir 38 through nozzle 30. The expulsion of the injectable fluid forces outlet check ball 44 forward, and the injectable fluid passes through check ball chamber 46 around the outside of the check ball. Check ball 44 and check ball chamber 46 should be sized so that there is sufficient clearance around check ball 44 when it is in its forward position toward nozzle 30. In the depicted embodiment, there is approximately 0.007 inches of clearance around all sides of check ball 44 when in its advanced position. The expulsion of injectable fluid out of fluid reservoir 38 also aids in maintaining inlet check valve 52 closed, to prevent injectable fluid from flowing back into the fluid supply.

As seen in Fig. 3, poppet 120 may be sized so that it covers holes 134 when in its rearmost position. This closes off channel 132 to prevent unnecessary waste of pressurized gas, by preventing further delivery of gas into gas reservoir 66.

Fig. 3 shows piston 60 in its fully advanced position, and reciprocating structure 92 in its rearmost position relative to housing 26. At this point, gas reservoir 66 and piston chamber 74 have not yet vented, and those areas remain at a substantial pressure differential above atmosphere. Piston 60 thus remains advanced.

As housing 26 is withdrawn from the injection site, spring 102 urges reciprocating structure 92 forward relative to housing 26. This in turn causes slidable valve structure 90 to move relative to valve body 100. Eventually, gas reservoir 66 and piston chamber 74 are vented when holes 130 of valve structure 90 pass forward beyond U-cup seal 180. As the pressure is released, spring 76 urges against piston 60, causing it to return from its advanced position to its retracted position against bulkhead 68, as seen in Figs. 1 and 2. As indicated above, the exhausted gas may be used to actuate dye marker 200, by fluidly coupling the venting chamber and dye marker with hose 208.

As piston 60 retracts, plunger 36 is retracted from its advanced position within fluid reservoir 38. The retreat of plunger 36 opens inlet check valve 52 and draws a new dose of fluid into fluid reservoir 38. The outlet check valve remains closed, due to its spring and the vacuum pressure created by the retraction of plunger 36. Eventually, the device returns to the primed position shown in Fig. 1 and is ready to deliver another injection of fluid in the manner just described.

Construction and Operation of Fluid Supply Fittings

It should be appreciated that many different types of fluids may be used in connection with the embodiments described above. For example, the device may be used with more than one type of injectable drug. In medical and veterinary applications, it will often be critical that the device is cleaned between uses with different types of injectable fluid. Alternatively, even where one type of injectable fluid is repeatedly used, it will often be desirable and/or necessary to periodically clean the injection device. For example, when a multi-use device is repeatedly used with the same injectable fluid, the fluid can crystallize in the channels and valves that form the fluid path, clogging and obstructing the flow. Accordingly, it will often be desirable to clean the device every time that a container of injectable fluid is exhausted, prior to coupling a new container to the device. Typically, a cleaning fluid is used to clean the device.

Fig. 5 depicts a fitting assembly 300 for connecting a fluid supply to syringe assembly 28. As will be explained in detail below, fitting assembly 300 may be

configured to ensure that cleaning fluid is used between different types of injectable fluid. This is accomplished through use of two different types of adapter structures: one for injectable fluids, and a second for cleaning fluid. After an injectable fluid adapter is disconnected, another injectable fluid adapter cannot be coupled to the fitting assembly until a cleaning fluid adapter has been used.

Referring more particularly to Fig. 5, exemplary fitting assembly 300 is shown in an exploded view. Figs. 6-10 depict different components of the fitting assembly and an adapter 302 that may be used to connect a fluid supply to the fitting assembly. Figs. 6-10 also illustrate an exemplary method of operation. Fitting assembly 300 includes a locking member 304, a base 306 and a rotatable key member 308. These components are fitted together and secured to fluid cylinder 32 so that they are centered over inlet 42. A collar 310 may wrap around fluid cylinder 32 and connect to the underside of base 306. Collar 310, base 306 and locking member 304 are fixed relative to fluid cylinder 32, while rotatable key member 308 is rotatable about axis 320.

Fig. 5 also partially depicts a fluid supply, including adapter 302, which is configured to couple with fitting assembly 300. When adapter 302 is coupled to fitting assembly 300, fluid may be drawn from the fluid supply into fluid cylinder 32. Referring specifically to Fig. 6 (an isometric view of adapter 302), the adapter includes a cylindrical fitting 322 that fits over a corresponding fitting 324 provided on base 306. Fluid is drawn through a hose 326, through passages defined through fittings 322 and 324, and through inlet 42 into fluid cylinder 32.

The underside of adapter 302 includes a key structure having two protruding legs 340 and 342. Legs 340 and 342 have a generally L-shaped cross section, and are adapted to be received in corresponding L-shaped slots provided through rotatable key member 308. Specifically, as seen in Figs. 9A, 9B and 9C, rotatable key member 308 includes two opposed pairs of slots: (1) slots 344 and 346, and (2) slots 348 and 350. The spacing between slots 344 and 346 differs from the spacing between slots 348 and 350. Depicted adapter 302 is sized so that its legs fit only

into one of the pairs of slots. A second type of adapter is used for the other pair of slots.

Referring now primarily to Figs. 8-10, the operation of the fitting assembly and adapters will be described. In each of Figs. 8-10, a leftward pointing arrow (labeled "F") indicates the orientation of the depicted structure relative to the front of injection device 22 (Fig. 5 also shows F near fluid cylinder 32, indicating the front of the injection device). Adapter 302 is first inserted through aperture 360 provided through locking member 304. Aperture 360 is formed to have a number of widened cutout areas 362 (individually designated with letters a, b, c and d) located symmetrically around the aperture. The legs of adapter 302 are sized so that they must be aligned with an opposed pair of cutout areas 362 in order to fit through aperture 360.

Specifically, leg 340 is aligned with cutout area 362a and leg 342 is aligned with cutout area 362c. The legs are then inserted through aperture 360 so that the legs are received within the corresponding slots on rotatable key member 308. In particular, leg 340 is received within slot 346 and leg 342 is received within slot 344, as seen in Figs. 9A, 9B and 9C. Also, tab 370, which extends from the bottom of leg 340 (Figs. 6 and 7), extends into and is received within an arcuate slot 372 provided in base 306 (Fig. 10).

Once adapter 302 is fitted onto fitting assembly as just described, the adapter may be rotated clockwise up to ninety degrees from its initial inserted position. The corresponding rotational position of rotatable key member 308 is progressively shown in Figs. 9A, 9B and 9C. Fig. 9A corresponds to the initial position of adapter 302 just after it is mounted onto fitting assembly 300. The corresponding position of tab 372 within slot 370 is designated 370(9A) in Fig. 10.

Fig. 9B shows the orientation of adapter 302 and rotatable key member 308 after they have been rotated 45 degrees clockwise from the orientation shown in Fig. 9A. In this position, the adapter is locked into place and the fluid supply is ready to deliver fluid to fluid cylinder 32 (Figs. 1-5). The corresponding position of tab 370 within slot 372 is designated as 370(9B) in Fig. 10. Adapter 302 is retained in place

by edge portions 380 of locking member aperture 360. Specifically, edge portions 380 are held within slots 382, which are defined in part by the legs of adapter 302, in order to prevent the adapter from pulling upward off of fitting assembly 300.

After use, adapter 302 is rotated another 45 degrees in a clockwise direction, so that rotatable key member 308 and adapter 302 are rotated into the position shown in Fig. 9C. The corresponding position of tab 370 within slot 372 is designated as 370(9C) in Fig. 10. In this position, legs 340 and 342 align with cutouts 362_b and 362_d, allowing the adapter to be pulled through locking member 304 and decoupled from fitting assembly 300.

In Fig. 9C, rotatable key member has been rotated 90 degrees from the position shown in Fig. 9A, such that slots 350 and 348 are aligned with cutout areas 362_a and 362_c. As discussed above, adapter 302 does not match with slots 350 and 348, because of the different spacing between the slots. Therefore, if the user attempts to insert the adapter through locking member 304 by aligning adapter legs 340 and 342 with cutout areas 362_a and 362_c, rotatable key member 308 will obstruct the adapter and prevent it from being fully mounted on fitting assembly 300. Instead, a second type of adapter must be used, having legs that are configured to be received within slots 350 and 348.

Fitting assembly 300 typically is configured to constrain rotation of rotatable key member 308. As seen in Figs. 5 and 10, base 306 may include depressible structures 384, which each have a nub 384_a that is resiliently urged toward rotatable key member 308 (upward in Fig. 5). The facing surface of rotatable key member 308 includes a plurality of detents 386 in which nubs 384_a may be received, depending on the rotational position of rotatable key member 308. Detents 386 have an asymmetrical shape, in order to produce a ratchet-type effect, in which a given detent can only move in one direction (e.g., clockwise rotation of rotatable key member 308, as in the depicted embodiment) past a nub.

Typically, depressible structures 384 also extend into the slots in rotatable key member 308, to lock rotatable key member in various different rotational positions relative to base 306. For example, when rotatable key member 308 is in the position

shown in Fig. 9A, nubs 384a extend upward into slots 344 and 346. Specifically, as shown in Fig. 9A, slots 344 and 346 each have an outer-most rounded leg portion adjacent the edge of rotatable key member 308. When rotatable key member 308 is in the position shown in Fig. 9A, the depressible structures extend upward into these rounded leg portions to lock the rotatable key member in place and prevent it from rotating. Rotatable key member 308 is unlocked by inserting an appropriately sized adapter, as explained below.

The interaction described above between depressible structures 384 and rotatable key member 308 may be used to require alternating use of different types of adapters with fitting assembly 300. For purposes of illustration, a fluid supply adapter with legs sized to fit into slots 344 and 346 (e.g., adapter 302) will be referred to as a "Type A" adapter. An adapter with legs sized to fit into slots 348 and 350 will be referred to as a "Type B" adapter (not shown).

Beginning with Fig. 9A, prior to insertion of the Type A adapter (i.e., adapter 302), depressible structures 384 extend into slots 344 and 346 to rotationally lock rotatable key member 308 in place. To unlock rotatable key member 308, the Type A adapter is inserted, as shown in Fig. 9A, so that the adapter legs depress nubs 384a and force them out of their inserted positions within slots 344 and 346.

With rotatable key member thus unlocked, Type A adapter 302 and rotatable key member 308 are free to rotate 45 degrees clockwise into the operational position shown in Fig. 9B. In this position, depressible structures 384 are received within an opposed pair of detents 386. This prevents counter-clockwise rotation of rotatable key member 308 back into the position shown in Fig. 9A, requiring the user to rotate the device clockwise into the position shown in Fig. 9C in order to remove type A adapter 302.

Accordingly, when the operator desires to remove Type A adapter 302 (for example, after emptying a container of vaccine), the adapter and rotatable key member 308 are rotated into the position shown in Fig. 9C. In this position, depressible structures lock into slots 348 and 350, to prevent any further rotation of rotatable key member 308. At this point, a Type B adapter must be used to unlock

rotatable key member 308, because the spacing between slots 348 and 350 differs from the spacing between slots 344 and 346.

This requires the user to alternate between Type A and Type B adapters. After using and removing a Type A adapter (e.g., with a particular vaccine), another
5 Type A adapter cannot be used until a Type B adapter is connected to and removed from fitting assembly. This can be advantageously employed to require use of a cleaning fluid between different types of injectable fluids, or before replacing a spent fluid supply, such as a vaccine container, with another supply of the same type of injectable fluid. Also, a storage cap may be provided in the form of a Type A
10 adapter, requiring the operator to clean the device (e.g., with a Type B adapter and cleaning fluid) both before and after using the storage cap.

While the present invention has been particularly shown and described with reference to the foregoing preferred embodiments, those skilled in the art will understand that many variations may be made therein without departing from the
15 spirit and scope of the invention as defined in the following claims. The description of the invention should be understood to include all novel and non-obvious combinations of elements described herein, and claims may be presented in this or a later application to any novel and non-obvious combination of these elements. Where the claims recite "a" or "a first" element or the equivalent thereof, such
20 claims should be understood to include incorporation of one or more such elements, neither requiring nor excluding two or more such elements.

We Claim:

1. A needle-free injection device, comprising:

5 a syringe assembly configured to draw in and expel injectable fluid, the syringe assembly being configured to expel injectable fluid upon application of pressurized gas to the syringe assembly from a gas reservoir;

a slidable valve assembly configured to control buildup and release of pressure within the gas reservoir, the slidable valve assembly being progressively
10 movable from a priming position to a charging position, and then to a firing position, where:

when in the priming position, the slidable valve assembly fluidly couples the gas reservoir to atmosphere,

when moved from the priming position to the charging position, the slidable
15 valve assembly fluidly couples the gas reservoir with a pressurized gas supply conduit, and

when moved from the charging position to the firing position, the slidable valve assembly causes the gas reservoir to be fluidly coupled with the syringe assembly, enabling pressurized gas from the gas reservoir to act upon the syringe
20 assembly.

2. The needle-free injection device of claim 1, further comprising a pressure-activated valve coupled between the gas reservoir and syringe assembly.

3. The needle-free injection device of claim 2, where when the slidable valve assembly is in the priming position, the slidable valve assembly fluidly couples the pressure-activated valve to the pressurized gas supply conduit, such that the pressure-activated valve closes to seal off the gas reservoir from the syringe assembly upon delivery of pressurized gas through the pressurized gas supply conduit.

4. The needle-free injection device of claim 3, where when the slidable valve assembly is in the firing position, the slidable valve assembly fluidly couples the pressure-activated valve to atmosphere.

5. The needle-free injection device of claim 1, further comprising a spring configured to bias the slidable valve assembly into the priming position.

6. The needle-free injection device of claim 1, further comprising a housing, where the slidable valve assembly includes a valve body fixedly mounted within the housing, and where the slidable valve assembly also includes a sliding structure slidably supported within the valve body, and where relative fore-and-aft movement of the sliding structure and valve body defines the priming, charging and firing positions of the slidable valve assembly.

7. The needle-free injection device of claim 6, where the syringe assembly is fixedly connected to the sliding structure of the slidable valve assembly.

8. The needle-free injection device of claim 7, where syringe assembly includes a nozzle end that extends away from the housing, such that the needle-free injection device is configured to allow a user to grasp the housing and press the nozzle end onto an injection site so as to cause the slidable valve assembly to progressively move from the priming position to the firing position.

9. The needle-free injection device of claim 8, where the needle-free injection device includes a spring configured to return the slidable valve assembly to the priming position upon withdrawal of the needle-free injection device from the injection site.

5

10. The needle-free injection device of claim 1, further comprising a locking mechanism configured to prevent the slidable valve assembly from moving from the priming position toward the firing position.

10

11. The needle-free injection device of claim 10, further comprising a user-actuable trigger configured to unlock the locking mechanism.

15

12. The needle-free injection device of claim 11, where the user-actuable trigger is further configured to open a supply valve and thereby permit delivery of pressurized gas through the pressurized gas supply conduit.

13. The needle-free injection device of claim 1, where the syringe assembly includes a plunger movably disposed within a fluid cylinder.

20

14. The needle-free injection device of claim 13, further comprising a piston movably disposed within a piston cylinder, where the piston is secured to an end of the plunger, such that advancing the piston causes the plunger to advance within the fluid cylinder and thereby expel fluid from the fluid cylinder.

25

15. The needle-free injection device of claim 13, where the syringe assembly includes an adjustment mechanism configured to adjust how far the plunger can be retracted from an end of the fluid cylinder, to thereby adjust a maximum volume of injectable fluid that can be expelled from the syringe assembly with a single injection.

30

16. The needle-free injection device of claim 15, where the syringe assembly includes indicia adapted to provide quantitative indication of the maximum volume of injectable fluid.

5 17. The needle-free injection device of claim 1, further comprising a fitting assembly configured to couple a fluid supply to an inlet of the syringe assembly, where the inlet includes a check valve to prevent backflow through the fitting assembly.

10 18. The needle-free injection device of claim 1, further comprising a marking device adapted to place a mark on or near an injection site to indicate an injection has occurred.

15 19. The needle-free injection device of claim 18, where the marking device is pressure-activated, and where the marking device is fluidly coupled with the needle-free injection device, such that the marking device is activated upon post-injection venting of the needle-free injection device.

20. A needle-free injection device, comprising:

a housing;

a gas reservoir;

5 a syringe assembly operatively secured to the housing so that the syringe assembly is movable back-and-forth relative to the housing along an axis, the syringe assembly having a variable-volume fluid reservoir and a nozzle, the syringe assembly being configured to expel injectable fluid out of the nozzle upon application of pressurized gas to the syringe assembly to contract the fluid reservoir; and

10 a valve coupled between the gas reservoir and the syringe assembly, the valve being configured so that opening the valve fluidly couples the gas reservoir with the syringe assembly to enable application of pressurized gas from the gas reservoir to the syringe assembly, where the valve is operable via relative motion occurring between the syringe assembly and the housing along the axis.

15

21. The needle-free injection device of claim 20, further comprising a slidable valve assembly configured to control buildup and release of pressure within the gas reservoir, including a valve body fixedly mounted within the housing and a sliding structure slidably held within the valve body, where the sliding structure is
20 secured to the syringe assembly such that the syringe assembly and sliding structure are movable together relative to the housing and valve body.

22. The needle-free injection device of claim 21, where the sliding structure is movable so as to progressively move the slidable valve assembly from a priming position to a charging position, and then to a firing position, where:

5 when in the priming position, the slidable valve assembly fluidly couples the gas reservoir to atmosphere,

when moved from the priming position to the charging position, the slidable valve assembly fluidly couples the gas reservoir with a pressurized gas supply conduit, and

10 when moved from the charging position to the firing position, the slidable valve assembly causes the gas reservoir to be fluidly coupled with the syringe assembly by opening the valve, enabling pressurized gas from the gas reservoir to act upon the syringe assembly.

23. The needle-free injection device of claim 22, further comprising a
15 spring configured to bias the slidable valve assembly into the priming position.

24. The needle-free injection device of claim 22, where the nozzle of the syringe assembly is spaced from the housing, such that the needle-free injection device is configured to allow a user to grasp the housing and press the nozzle onto an
20 injection site so as to cause the slidable valve assembly to progressively move from the priming position to the firing position.

25. The needle-free injection device of claim 24, further comprising a spring configured to return the slidable valve assembly to the priming position upon
25 withdrawal of the needle-free injection device from the injection site.

26. The needle-free injection device of claim 20, where the syringe assembly includes a plunger movably disposed within a fluid cylinder.

27. The needle-free injection device of claim 26, further comprising a piston movably disposed within a piston cylinder, where the piston is secured to an end of the plunger, such that advancing the piston causes the plunger to advance within the fluid cylinder and thereby expel fluid from the fluid cylinder.

5

28. The needle-free injection device of claim 26, where the syringe assembly includes an adjustment mechanism configured to adjust how far the plunger can be retracted from an end of the fluid cylinder, to thereby adjust a maximum volume of injectable fluid that can be expelled from the syringe assembly with a single injection.

10

29. The needle-free injection device of claim 28, where the syringe assembly includes indicia adapted to provide quantitative indication of the maximum volume of injectable fluid.

15

30. The needle-free injection device of claim 20, further comprising a marking device adapted to place a mark on or near an injection site to indicate an injection has occurred.

20

31. The needle-free injection device of claim 30, where the marking device is pressure-activated, and where the marking device is fluidly coupled with the needle-free injection device, such that the marking device is activated upon post-injection venting of the needle-free injection device.

32. A needle-free injection system, comprising:

an injection device; and

a fitting assembly configured to receive an injectable fluid supply adapter so as to permit the injection device to be supplied with injectable fluid through the injectable fluid supply adapter, the fitting assembly being further configured to receive a cleaning fluid supply adapter so as to permit the injection device to be supplied with cleaning fluid through the cleaning fluid supply adapter,

where the fitting assembly is adapted to prevent, after a first attachment and removal of an injectable fluid supply adapter, another attachment of an injectable fluid supply adapter, until an intervening attachment and removal of a cleaning fluid supply adapter has occurred.

33. The needle-free injection system of claim 32, where the fitting assembly includes a movable key structure that is movable from a first position, in which the movable key structure prevents attachment of an injectable fluid supply adapter but permits attachment of a cleaning fluid supply adapter, to a second position, in which the movable key structure prevents attachment of a cleaning fluid supply adapter but permits attachment of an injectable fluid supply adapter.

34. The needle-free injection system of claim 32, where the fitting assembly includes a key structure that is selectively rotatable into two different states:

5 a first state, in which the key structure prevents attachment of an injectable fluid supply adapter but permits attachment of a cleaning fluid supply adapter; and

a second state, in which the key structure prevents attachment of a cleaning fluid supply adapter but permits attachment of an injectable fluid supply adapter,

10 where attachment and removal of a cleaning fluid supply adapter rotates the key structure from the first state to the second state, and where attachment and removal of an injectable fluid supply adapter rotates the key structure from the second state to the first state.

35. The needle-free injection system of claim 34, where the fitting assembly includes resilient projections adapted to constrain rotation of the key structure.

36. A needle-free injection device, comprising:

a user-grippable housing;

20 a syringe assembly movably secured to the housing and configured to expel injectable fluid out of a nozzle upon application of pressurized gas to the syringe assembly; and

25 a pressurized gas delivery mechanism disposed within the housing and configured to selectively apply pressurized gas to the syringe assembly, where the pressurized gas delivery mechanism is at least partly actuated by pressing the nozzle onto an injection site so that the syringe assembly moves relative to the housing.

37. A needle-free injection device, comprising:

a gas reservoir;

a syringe assembly configured to expel injectable fluid out of a nozzle upon application of pressurized gas from the gas reservoir to the syringe assembly; and

5 a pressurized gas delivery mechanism configured to couple with a source of pressurized gas and control pressurization of the gas reservoir, the pressurized gas delivery mechanism being configured to charge the gas reservoir via a two-stage charging process, in which a chamber of a pressure valve is first pressurized to cause the pressure valve to close and thereby seal off the gas reservoir from the syringe
10 assembly, and in which, after the pressure valve has closed, the pressurized gas delivery mechanism causes the gas reservoir to be pressurized through a fluid coupling of the gas reservoir with the source of pressurized gas.

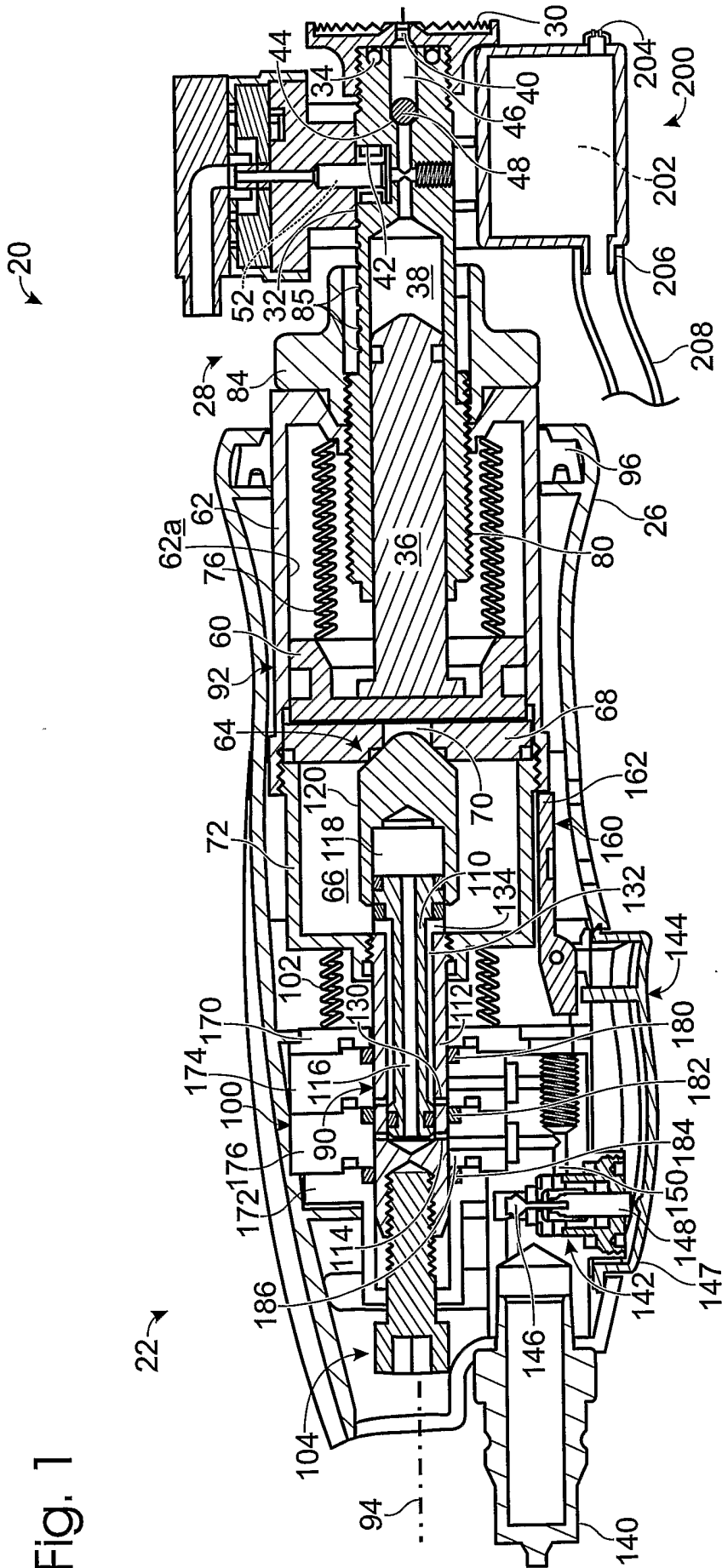

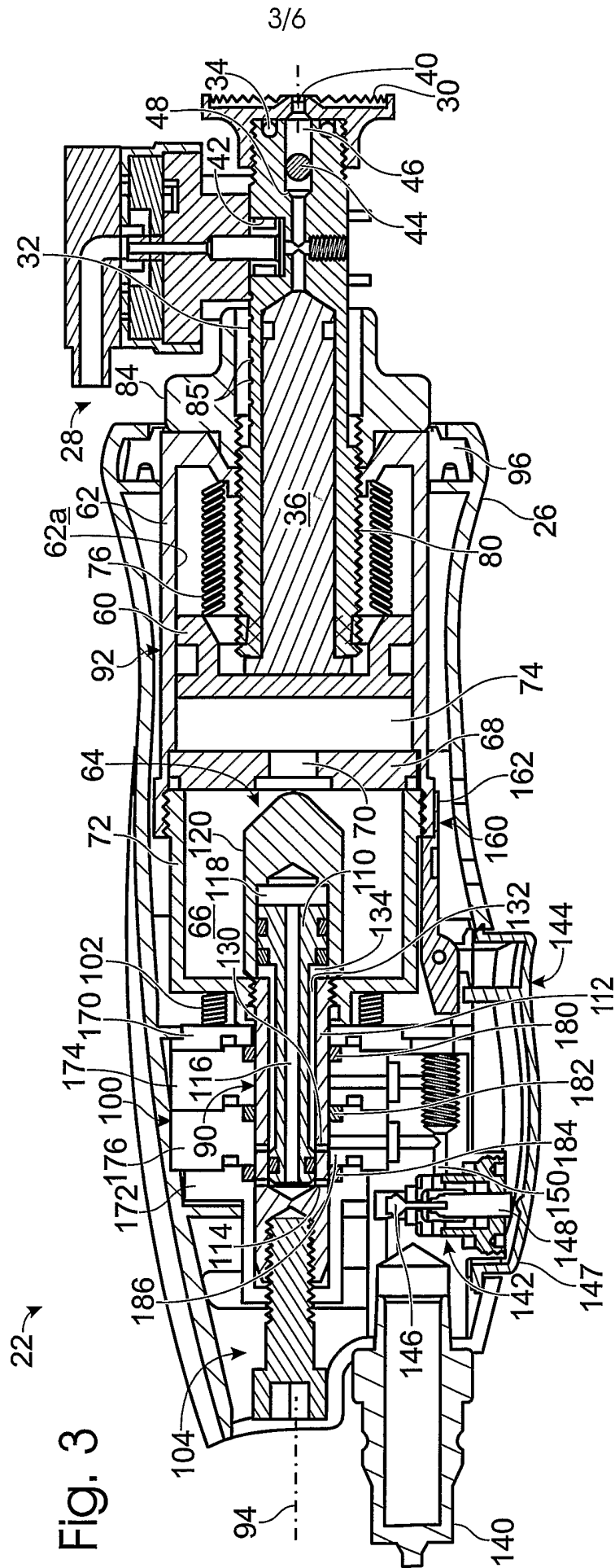

Fig. 3

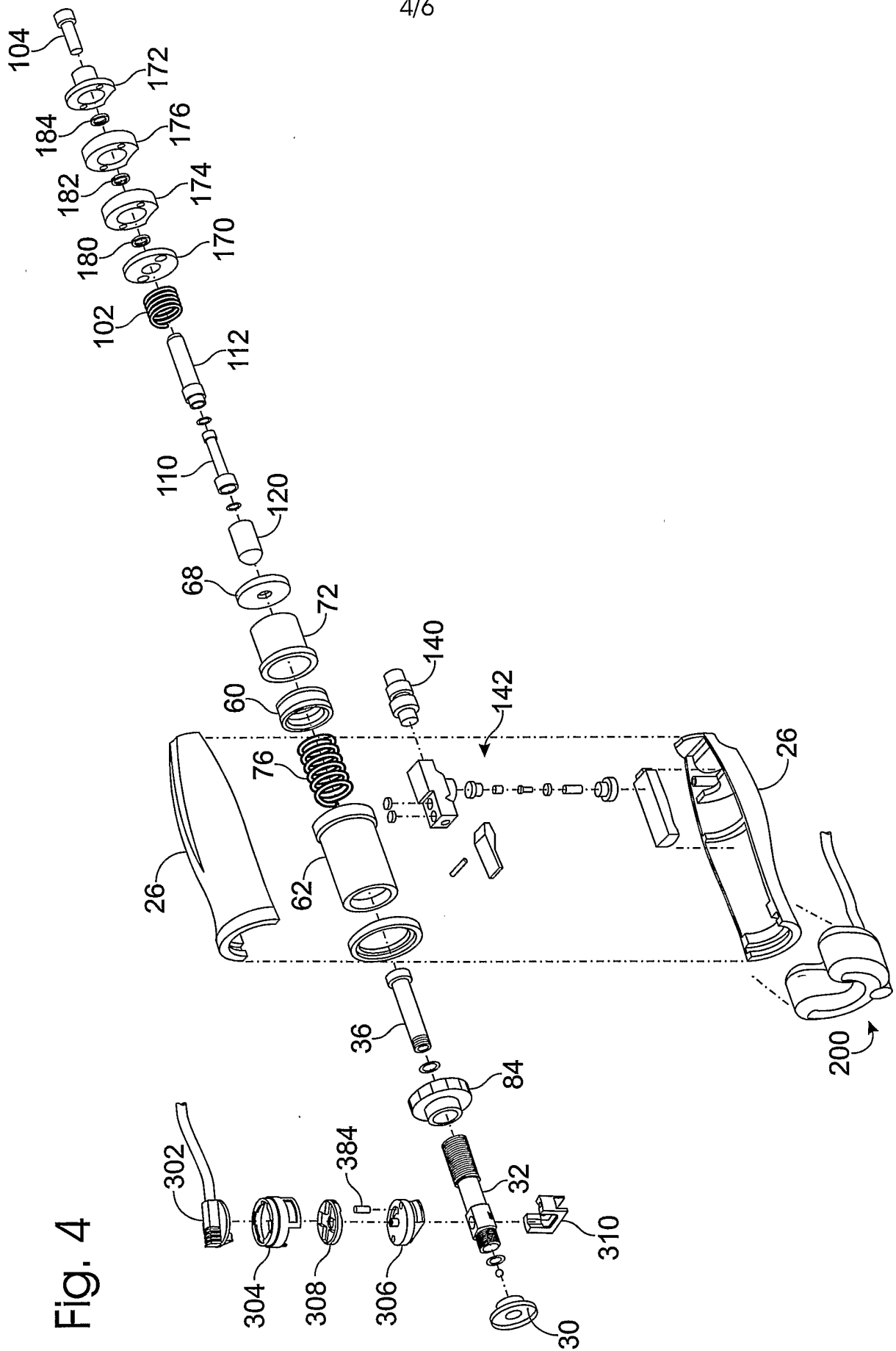

Fig. 4

Fig. 5

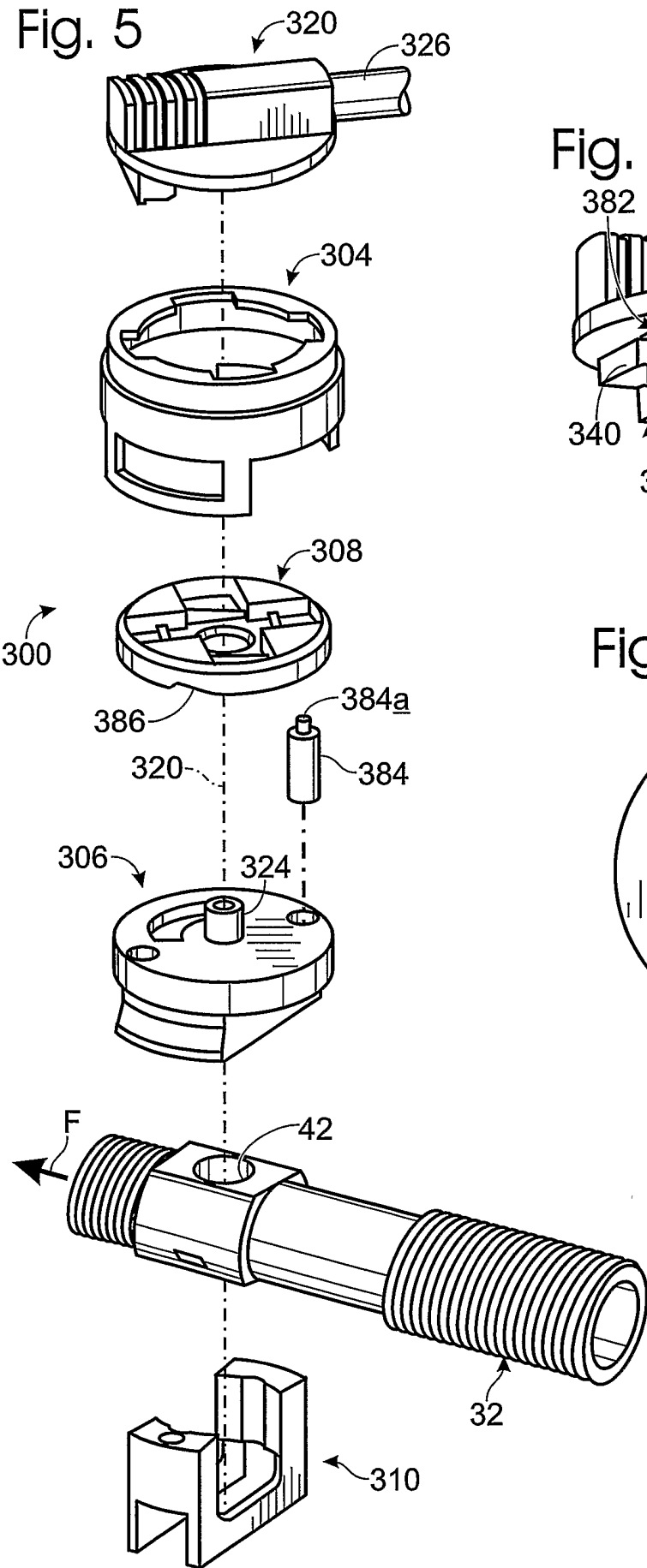

Fig. 6

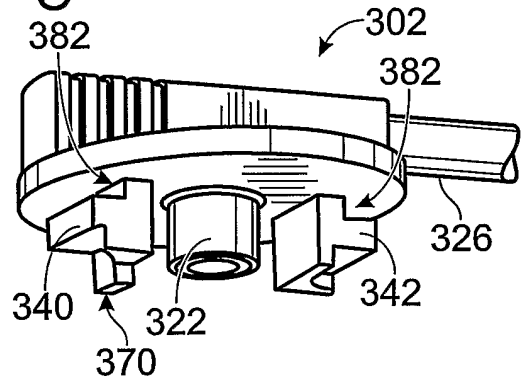

Fig. 7

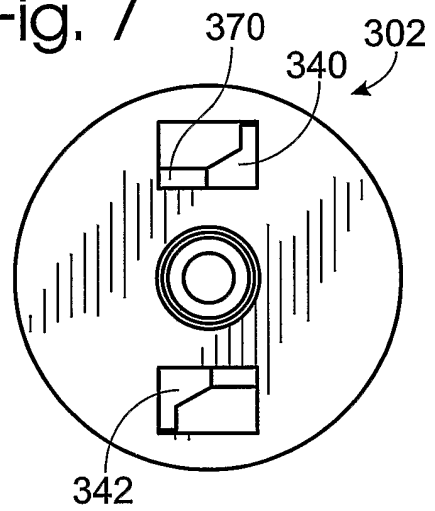

Fig. 8

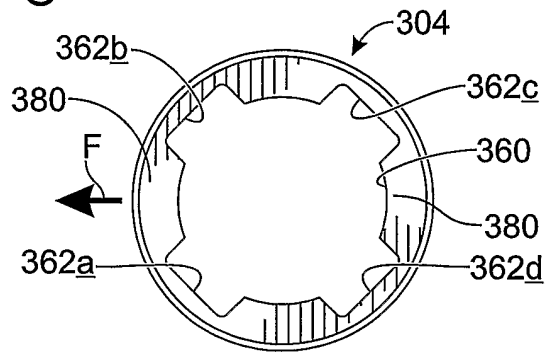

Fig. 9A

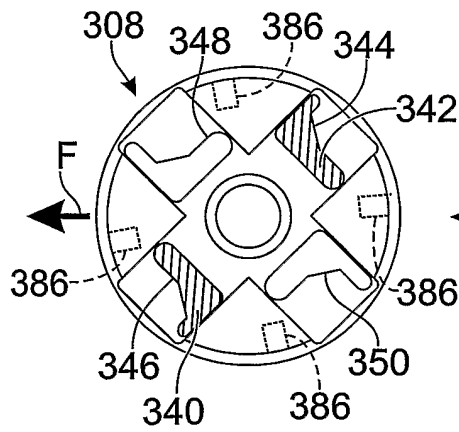

Fig. 9B

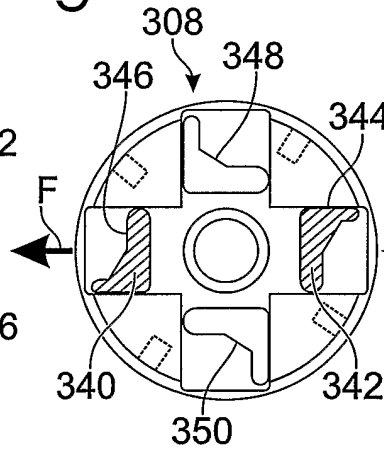

Fig. 9C

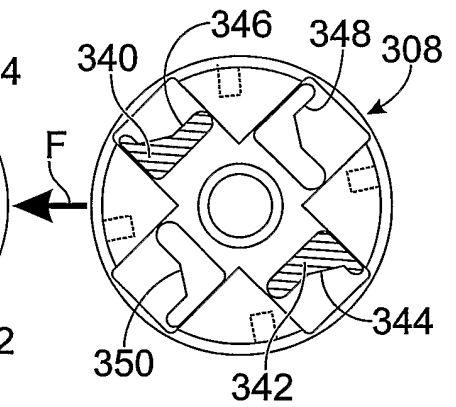
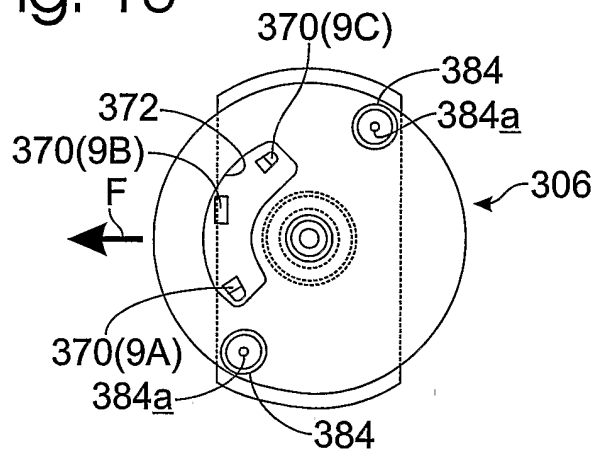

Fig. 10



INTERNATIONAL SEARCH REPORT

International application No.

PCT/US03/16446

A. CLASSIFICATION OF SUBJECT MATTER		
IPC(7) : A61M 5/30 US CL : 604/70		
According to International Patent Classification (IPC) or to both national classification and IPC		
B. FIELDS SEARCHED		
Minimum documentation searched (classification system followed by classification symbols) U.S. : 604/70		
Documentation searched other than minimum documentation to the extent that such documents are included in the fields searched NONE		
Electronic data base consulted during the international search (name of data base and, where practicable, search terms used) None		
C. DOCUMENTS CONSIDERED TO BE RELEVANT		
Category *	Citation of document, with indication, where appropriate, of the relevant passages	Relevant to claim No.
X	US 3,714,943 A (YANOF et al) 06 February 1973 (06.02.1973), see Figs. 1, 3, 5,6 and related text.	20,21,26,27,28,29
X	US 6,096,002 A (LANDAU) 01 August 2000 (01.08.2000), see figs. 11, 3, 7 and related text.	20, 36
A	US 3,945,379 A (PRITZ et al) 23 March 1976 (23.03.1976), see Figs. 1 and 5 and related text.	1-37
<input type="checkbox"/> Further documents are listed in the continuation of Box C. <input type="checkbox"/> See patent family annex.		
* Special categories of cited documents:		
"A"	document defining the general state of the art which is not considered to be of particular relevance	"T" later document published after the international filing date or priority date and not in conflict with the application but cited to understand the principle or theory underlying the invention
"E"	earlier application or patent published on or after the international filing date	"X" document of particular relevance; the claimed invention cannot be considered novel or cannot be considered to involve an inventive step when the document is taken alone
"L"	document which may throw doubts on priority claim(s) or which is cited to establish the publication date of another citation or other special reason (as specified)	"Y" document of particular relevance; the claimed invention cannot be considered to involve an inventive step when the document is combined with one or more other such documents, such combination being obvious to a person skilled in the art
"O"	document referring to an oral disclosure, use, exhibition or other means	"&" document member of the same patent family
"P"	document published prior to the international filing date but later than the priority date claimed	
Date of the actual completion of the international search		Date of mailing of the international search report
22 August 2003 (22.08.2003)		08 OCT 2003
Name and mailing address of the ISA/US Mail Stop PCT, Attn: ISA/US Commissioner for Patents P.O. Box 1450 Alexandria, Virginia 22313-1450 Facsimile No. (703)305-3230		Authorized officer Michael J Hayes' <i>Deane Kewele for</i> Telephone No. 703-308-0858