

(19) World Intellectual Property Organization
International Bureau



(43) International Publication Date
21 December 2000 (21.12.2000)

PCT

(10) International Publication Number
WO 00/78050 A1

(51) International Patent Classification⁷: H04N 7/173,
5/445

(21) International Application Number: PCT/US00/40148

(22) International Filing Date: 7 June 2000 (07.06.2000)

(25) Filing Language: English

(26) Publication Language: English

(30) Priority Data:
60/138,868 11 June 1999 (11.06.1999) US
60/164,648 10 November 1999 (10.11.1999) US

(71) Applicant: UNITED VIDEO PROPERTIES, INC.
[US/US]; 7140 South Lewis Avenue, Tulsa, OK 74136
(US).

(72) Inventors: HERRINGTON, W., Benjamin; 725 West
20th Street, Tulsa, OK 74107 (US). THOMAS, William,
L.; 11611 South 70th East Avenue, Bixby, OK 74008
(US). KELLY, Robert, L.; 163 Amsterdam Avenue, No.

191, New York, NY 10023 (US). ALLISON, Donald,
W.; 3411 South 132nd East Avenue, Tulsa, OK 74134
(US). WILLIAMSON, Steven, C.; 8226 S. Toledo, Tulsa,
OK 74137 (US). ANDERSON, Lyle, C.; 45 Hamilton
Road, Chappaqua, NY 10514 (US). DEMERS, Timothy,
B.; 7724 South Hudson Avenue, Tulsa, OK 74136 (US).
DEWEESE, Toby; 4721 East 87th Street, Tulsa, OK
74137 (US). ELLIS, Michael, D.; 1300 Kingwood Place,
Boulder, CO 80304 (US). BOYLAN, Peter, C., III; 6600
South Timberlane Road, Tulsa, OK 74136 (US).

(74) Agents: GUILIANO, Joseph, M. et al.; Fish & Neave,
1251 Avenue of the Americas, New York, NY 10020 (US).

(81) Designated States (*national*): AE, AG, AL, AM, AT, AU,
AZ, BA, BB, BG, BR, BY, CA, CH, CN, CR, CU, CZ, DE,
DK, DM, DZ, EE, ES, FI, GB, GD, GE, GH, GM, HR, HU,
ID, IL, IN, IS, JP, KE, KG, KP, KR, KZ, LC, LK, LR, LS,
LT, LU, LV, MA, MD, MG, MK, MN, MW, MX, MZ, NO,
NZ, PL, PT, RO, RU, SD, SE, SG, SI, SK, SL, TJ, TM, TR,
TT, TZ, UA, UG, UZ, VN, YU, ZA, ZW.

(84) Designated States (*regional*): ARIPO patent (GH, GM,
KE, LS, MW, MZ, SD, SL, SZ, TZ, UG, ZW), Eurasian

[Continued on next page]

(54) Title: INTERACTIVE TELEVISION APPLICATION SYSTEM WITH HAND-HELD APPLICATION DEVICE

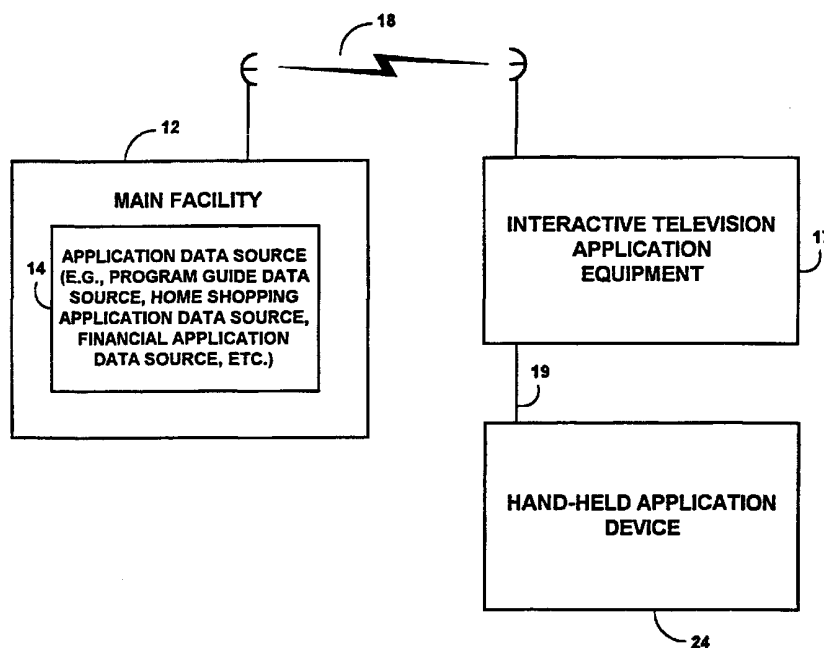

(57) Abstract: A hand-held application device provides users with opportunities to access television-related or other applications and to control television-related applications running on user television equipment. The hand-held application device may have a touch-sensitive screen with controls that are coordinated with the features of the television-related or other applications.



WO 00/78050 A1



patent (AM, AZ, BY, KG, KZ, MD, RU, TJ, TM), European patent (AT, BE, CH, CY, DE, DK, ES, FI, FR, GB, GR, IE, IT, LU, MC, NL, PT, SE), OAPI patent (BF, BJ, CF, CG, CI, CM, GA, GN, GW, ML, MR, NE, SN, TD, TG).

— *Before the expiration of the time limit for amending the claims and to be republished in the event of receipt of amendments.*

Published:

— *With international search report.*

For two-letter codes and other abbreviations, refer to the "Guidance Notes on Codes and Abbreviations" appearing at the beginning of each regular issue of the PCT Gazette.

INTERACTIVE TELEVISION APPLICATION SYSTEM
WITH HAND-HELD APPLICATION DEVICE

Background of the Invention

This invention relates to interactive
5 television application systems, and more particularly,
to interactive television application systems in which
television application functionality may be provided by
a hand-held device or coordinated between a hand-held
device and a user's television equipment.

10 Interactive television applications typically
run on a user's set-top box. Examples of interactive
television applications include interactive television
program guides, e-mail, home shopping, wagering and
other e-commerce applications, financial applications,
15 TV Web browsers, games, and other television based
applications. Running these applications typically
excludes other users from watching television other
than the application being viewed. In addition,
running such applications on a stationary platform on

- 2 -

the set-top box prevents users from accessing the features of such systems when away from the stationary platform.

It is therefore an object of the present invention to provide an interactive television application system having a hand-held application device with display.

It is a further object of the present invention to coordinate interactive television application functionality between an application running on the user's television equipment and an application running on a hand-held application device.

Summary of the Invention

These and other objects of the present invention are accomplished by providing a portable hand-held application device with display as described, for example, in Herrington et al. U.S. provisional patent application Serial No. 60/138,868, filed June 11, 1999, and Ellis U.S. provisional patent application Serial No. 60/164,648, filed November 10, 1999, which are hereby incorporated by reference herein in their entireties.

The hand-held application device may be any suitable hand-held device, such as a display remote, touch-screen remote, personal digital assistant (PDA), ebook or other hand-held device. The hand-held application device provides a user with access to interactive television application functionality remotely or while viewing a television program. In one suitable approach, the hand-held application device may run a client version of an interactive television application that requests application data from an

- 3 -

application server running on the user's television equipment. In another suitable approach, the hand-held application device acts as an independent platform running an interactive application that may run
5 independently and may communicate with a similar interactive application running on the user's television equipment. The hand-held application device may provide, for example, a portable electronic program guide including various features of interactive program
10 guides, Internet-based program guides, and printed program guides.

Interactive television applications may include, for example, applications that provide information related to television programming or that
15 provide interactive features associated with television programming, such as, for example, interactive television program guides, home shopping applications, wagering applications, e-mail, and financial trading applications. Interactive television applications may
20 also include applications provided on user television equipment.

The hand-held application device may be offered to consumers for free or for a very low cost, as it may be advertising supported. Screens or pages
25 displayed by the device may contain passive or interactive advertisements. Providing the device at low consumer price may allow the device to be distributed in large volumes. This may increase the value of the device to advertisers. Users of the
30 device may not have to live in a special area, subscribe to any kind of digital cable or satellite service, or have an Internet account, to use the device if desired. Once a platform like this has been

- 4 -

distributed, there will be continued opportunities for growth. New software can be downloaded. It can support future marketing opportunities, and it offers the ability to add user features at a later date, as
5 either a free or pay upgrade.

The hand-held application device may be of a size to fit in a pocket or purse. The device may have a touch-screen LCD display, a two-way paging interface, and may run on standard batteries. The paging
10 interface may continuously collect TV listing data and store the data in local memory. It may also download advertisements while the device is in normal use. This may be done by for example buying time from a national paging service.

15 The device may have a fold-down cover to protect the display from damage or accidental activation. Opening the cover automatically may turn the device on and activate its display. The first display may be, for example, a main menu, which may
20 include interactive advertisements. One of the items on the menu may be a television guide. Selecting the guide feature may bring up a guide main menu, display of program listings or any other suitable guide display. When a user select a listing, the device may
25 display a description of a program associated with the listing. Advertisements may be programming related, in which case selecting them may bring up more information about a program, allow reminders to be set, or any other suitable function. Advertisements for other
30 products may allow a user to get more information or purchase a product.

The portable hand-held application device may include many of the features of interactive program

- 5 -

guides, such as listings by time, by channel, by category, favorite channels or any other guide feature. It may allow the user to set reminders and have them appear on the device, with both an audio alert and a display. Via a paging return, for example, the device can be used to set reminders or schedule recordings remotely. The portable device may be used for collecting data. For example, it might be used to send out surveys. It may also be used to collect audience ratings information. With an appropriate point-of-purchase device, for example, may be used to distribute electronic coupons.

The device may also include an infra-red emitter. This may allow a user to use the device as a remote control to operate an interactive television program guide on a television set and other home entertainment equipment. A paging system may be used, for example, to upload device type information and download infra-red codes. When used in this mode, keys may be displayed on the device, and the user may touch the screen to generate commands. The keys can be context sensitive, where only the keys of interest are displayed at any time.

The portable device may also offer other PDA-type functions, perhaps at an additional cost. For example, it may support e-mail, a calendar, a contact list, web browsing, a calculator, or any other suitable application. It may support data services, such as news, weather, sports, traffic, or any other suitable data service. It may be used as a pager. With suitable hardware resources, the portable program guide might include advanced communication functions. For example, it might allow a user to remotely monitor the

- 6 -

home equipment -- find out if the system is turned on, what channel is on, etc. It might also allow a user to listen to audio from a selected TV channel, or offer audio channels. The portable device may also serve as
5 an ebook.

Further features of the invention, its nature and various advantages will be more apparent from the accompanying drawings, in which like reference characters refer to like parts throughout, and the
10 following detailed description of the preferred embodiments.

Description of the Drawings

FIG. 1 shows a schematic view of an illustrative system in accordance with the present
15 invention;

FIGS. 2a-2f show illustrative arrangements for the interactive television application equipment and hand-held application device of FIG. 1, in accordance with the present invention;

20 FIG. 3 shows a schematic view of the hand-held application device of FIG. 1, in accordance with the present invention;

FIG. 4 shows a schematic view of the user television equipment of FIGS. 2a-2f, in accordance with
25 the present invention;

FIG. 5 shows a more generalized schematic view of the user television equipment of FIGS. 2a-2f, in accordance with the present invention;

30 FIG. 6 shows an illustrative menu screen in accordance with the present invention;

FIG. 7 shows an illustrative browse display in accordance with the present invention;

- 7 -

FIG. 8 shows an illustrative information screen in accordance with the present invention;

FIG. 9 shows an illustrative pay-per-view ordering screen in accordance with the present
5 invention;

FIG. 10 shows an illustrative remote screen in accordance with the present invention;

FIG. 11 shows an illustrative primary guide main menu screen in accordance with the present
10 invention;

FIG. 12 shows an illustrative display of program listings by time in accordance with the present invention;

FIG. 13 shows an illustrative premiums screen
15 in accordance with the present invention;

FIG. 14 shows an illustrative home page in accordance with the present invention;

FIG. 15 shows an illustrative Editor's Picks page in accordance with the present invention;

FIGS. 16a and 16b show illustrative My TV Listings pages in accordance with the present
20 invention;

FIG. 16c shows an illustrative page of program listings by criteria in accordance with the
25 present invention;

FIG. 17 shows an illustrative about page in accordance with the present invention;

FIG. 18 is a flowchart of illustrative steps involved in providing interactive television and other
30 application features with the hand-held application device of FIG. 1, in accordance with the present invention;

- 8 -

FIG. 19 a flowchart of illustrative steps involved in coordinating features between primary applications running within the interactive television application equipment of FIG. 1 and supplemental
5 applications running on the hand-held access device of FIG. 1; and

FIG. 20 is a flowchart of illustrative steps involved in providing interactive television program guide functionality using the hand-held application
10 device of FIG. 1.

Detailed Description of the Preferred Embodiments

An illustrative system 10 in accordance with the principles of the present invention is shown in FIG. 1. System 10 may include main facility 12. Main
15 facility 12 provides interactive television application data from application data source 14 to interactive television application equipment 17 via communications link 18. There may be multiple main facilities 12 for providing data for a number of applications, but only
20 one main facility 12 has been shown in FIG. 1 to avoid over-complicating the drawing. There are preferably numerous pieces or installations of interactive television application equipment 17, each linked to main facility 12 by a respective communications link 18
25 although only one such piece or installation of interactive television application equipment 17 is shown in FIG. 1 to avoid over-complicating the drawing. Link 18 may be a satellite link, a telephone network link, a cable or fiber optic link, a microwave link, an
30 Internet link, a digital subscriber line (DSL), a combination of such links, or any other suitable communications link. In another suitable approach,

- 9 -

interactive television application data may be generated by interactive television application equipment 17, in which case main facility 12 may be unnecessary. In still another suitable approach, main
5 facility 12 may provide interactive television application data directly to hand-held application device 24 via a suitable link (e.g., a two-way paging - frequency link), in which case all or portions of interactive television application equipment it may be
10 unnecessary. For the purposes of clarity, the remaining discussion will describe an approach in which main facility 12 provides interactive television application data to one or more interactive television application equipments 17.

15 The interactive television application data transmitted by main facility 12 to interactive television application equipment 17 may include any data suitable for the application supported by main facility 12. If main facility 12 provides interactive
20 television program guide data, for example, the data may include television programming data (e.g., program identifiers, times, channels, titles, and descriptions) and other data for services other than television program listings (e.g., help text, pay-per-view
25 information, weather information, sports information, music channel information, associated Internet Web links, associated software, etc.). Interactive television program guide data may also include unique identifiers for each showing of each program,
30 identifiers for program groupings (e.g., series, mini-series, orderable packages of programs, network lineups, etc.), or any other suitable identifier.

- 10 -

Interactive television applications may be implemented on interactive television application equipment 17 and hand-held application device 24. As used herein, a "primary" application is intended to mean an interactive application that runs on interactive television application equipment 17. A primary application may be a server application that provides application data to hand-held application device 24 in response to one or more application communications, or may be a version of an application that works cooperatively with a version of the application that runs on hand-held application device 24. As used herein, a "secondary" application is intended to mean an interactive application that runs on hand-held application device 24. A secondary application may be a client application that obtains data from a primary application, or may be a version of an interactive application that runs cooperatively with a primary application and that obtains application data from main facility 12.

The primary and secondary applications may communicate by exchanging one or more application communications. Application communications may include any client-server or peer-to-peer communication construct suitable for exchanging interactive application data or other data (such as digital frames for display by hand-held application device 24) between the primary and secondary applications via communications link 19. Application communications may include, for example, requests, commands, messages, or remote procedure calls.

Application communications may also involve complex communications between application constructs

- 11 -

running on hand-held application device 24 and interactive television application equipment 17. Application communications may, for example, be object based. Objects running in the primary and secondary
5 guides, for example, may communicate using an Object Request Broker (ORB). Interactive application data may, for example, be encapsulated as component object model (COM) objects and persisted to a stream that is transmitted over communications link 19. Application
10 communications may also include, for example, HTML formatted markup language documents (e.g., Web pages), that are exchanged between hand-held application device 24 and an Internet service system.

Six illustrative arrangements for interactive
15 television application equipment 17 and hand-held application device 24 are shown in FIGS. 2a-2f. As shown, interactive television application equipment 17 may include distribution equipment 21 located at application distribution facility 16, and user
20 television equipment 22. The primary application may run totally on user television equipment 22 using the arrangements of FIGS. 2a and 2b, or may run partially on user television equipment 22 and partially on application server 25 or Internet service system 61
25 using a suitable client-server or distributed processing arrangement such as shown in FIGS. 2c, 2d, 2e, and 2f. Application distribution facility 16 may be any suitable distribution facility, and may have distribution equipment 21.

30 Distribution equipment 21 of FIGS. 2a, 2b, 2c, 2d, 2e, and 2f is equipment suitable for providing interactive television application data to user television equipment 22 over communications link 20.

- 12 -

Distribution equipment 21 may include, for example, suitable transmission hardware for distributing interactive television application data on a television channel sideband, in the vertical blanking interval of a television channel, using an in-band digital signal, using an out-of-band digital signal, or by any other suitable data transmission technique. Analog or digital video signals (e.g., television programs) from television distribution facility 29 may also be distributed by distribution equipment 21 to user television equipment 22 over communications link 20 on multiple television channels. Alternatively, videos may be distributed to user television equipment 22 from television distribution facility 29 to user television equipment 22 directly. Television distribution facility 29 may be any suitable distribution facility (e.g., a cable system headend, a broadcast distribution facility, a satellite television distribution facility, or any other suitable type of television distribution facility). If desired, television distribution facility 29 and application distribution facility 16 may be the same facility.

Communications link 20 may be any communications link suitable for distributing interactive television application data to user television equipment 22. Communications link 20 may include, for example, a satellite link, a telephone network link, a cable or fiber optic link, a microwave link, an Internet link, a data-over-cable service interface specification (DOCSIS) link, a digital subscriber line (DSL), a paging frequency or other radio frequency link, a combination of such links, or any other suitable communications link. There are

- 13 -

typically multiple pieces of user television equipment 22 and multiple associated communications links 20, although only one piece of user television equipment 22 and communications link 20 are shown in FIGS. 2a-2f to avoid over-complicating the drawings. If desired, television programming and interactive television application data may be provided over separate communications links.

User television equipment 22 and hand-held application device 24 may communicate over communications link 19. There may only be a single communications link 19, such as when hand-held application device 24 obtains application data exclusively from user television as shown in FIGS. 2a, 2c, and 2e. Alternatively, there may be multiple communications links 19, such as when hand-held application device 24 obtains data directly from application distribution facility 16 as shown in FIGS. 2b, 2d, and 2f. In still another suitable approach, hand-held application device 24 may run totally independently and not communicate with user television equipment 22 at all.

Communications link 19 may be any suitable wired or wireless communications link or links over which digital or analog communications may take place between hand-held application device 24 and user television equipment 22, application distribution facility 17 or main facility 12. Communications link 19 may include, for example, a serial or parallel cable, a dial-up telephone line, a computer network or Internet link (e.g., 10Base2, 10Base 5, 10BaseT, 100BaseT, 10BaseF, T1, T3, etc.), an in-home network link, an infrared link), a radio-frequency link (e.g.,

- 14 -

a 900 MHz link, a paging-frequency link, or other radio frequency link), a satellite link, or any other suitable transmission link or combination of links. Communications link 19 may include a docking station
5 that connects hand-held device 24 to user television equipment 22 directly or via an in-home network. Any suitable transmission or access scheme may be used such as standard serial or parallel communications, Ethernet, Token Ring, Fiber Distributed Data Interface
10 (FDDI), Circuit-Switched Cellular (CSC), Cellular Digital Packet Data (CDPD), time division multiple access (TDMA), code division multiple access (CDMA), any other suitable transmission or access scheme, or any suitable combination thereof.

15 It is envisioned that the transmission media and scheme used will be appropriate for a particular implementation and that different media and schemes may be used on different communications links 19 when there are multiple communications links 19. It may be more
20 suitable that when in the home, for example, communications link 19 may be a RF or infrared link instead of some of the more complicated links that are more suited for data transmission over wider geographical areas. It may also be more suitable, for
25 example, that when hand-held application device 24 communicates directly with application distribution facility 16, communications link 19 may be a link more suited for data transmission over wider geographical areas, such as an Internet link.

30 Hand-held application device 24 and user television equipment 22 may communicate using any suitable network and transport layer protocols, if desired. They may communicate, for example, using a

- 15 -

protocol stack which includes Sequenced Packet Exchange/Internetwork Packet Exchange (SPX/IPX) layers, Transmission Control Protocol/Internet Protocol (TCP/IP) layers, AppleTalk Transaction Protocol/
5 Datagram Delivery Protocol (ATP/DDP) layers, a Wireless Access Protocol (WAP) layer, or any other suitable network or transport layer protocols. Hand-held application device 24 and user television equipment 22 may also be part of an in-home network using, for
10 example, the Jini networking protocol by Sun Microsystems. Network and transport layer protocols may be omitted from the system if desired.

Application data may be distributed by distribution equipment 21 to user television equipment
15 22 exclusively (such as shown in FIGS. 2a, 2c, and 2e), to user television equipment 22 and hand-held application device 24 jointly (such as shown in FIGS. 2b, 2d, and 2f), or to just hand-held application device 24, using any suitable scheme. For example,
20 application data may be provided in a continuous stream or may be transmitted at a suitable time interval (e.g., once per hour). If transmitted continuously, it may not be necessary to store the data locally on user television equipment 22 or hand-held application device
25 24. Rather, user television equipment 22 or hand-held application device 24 may extract data "on the fly" as it is needed. If desired, application distribution facility 16 may poll user television equipment 22 or hand-held device periodically for certain information
30 (e.g., pay program account information or information regarding programs that have been purchased and viewed using locally-generated authorization techniques).

- 16 -

Application data may also be provided using a suitable client-server approach or the Internet.

FIG. 2a shows an illustrative arrangement for interactive television application equipment 17 and
5 hand-held application device 24 in which a primary application runs totally on user television equipment 22. A secondary application running on hand-held application device 24 obtains application data via user television equipment 22. The secondary application may
10 obtain application data from a primary application acting as a server via application communications sent to user television equipment 22 via communications link 19. In another suitable approach, the secondary application may obtain application data directly from
15 user television equipment 22 without involving the primary application.

User television equipment 22 may, for example, receive application data as part of a continuous data stream, periodically, or in response to
20 polling requests from application distribution facility 17. In such approaches, application data may be automatically provided to hand-held application device 24 without requiring the secondary application to request it from the primary application. User
25 television equipment 22 may include, for example, a tap antenna and associated circuitry that demodulates, and if necessary decodes, the application data signal. The tap antenna may resend the data to hand-held application device 24 via communications link 19.
30 Alternatively, user television equipment 22 may receive application data from application distribution facility 16 and transmit that data to hand-held

- 17 -

application device 24 using any other suitable transmission scheme.

In still another suitable approach, application data may be stored by user television
5 equipment 22 and forwarded to hand-held application device 24. This approach may be desirable when, for example, the transfer rates of data between application distribution facility 16 and user television
10 equipment 22, and between user television equipment 22 and hand-held application device 24 are unequal.

FIG. 2b shows an illustrative arrangement for interactive television application equipment 17 and hand-held application device 24 in which hand-held application device obtains application data directly
15 from application distribution facility 16. Application distribution facility 16 may have communications device 27 for providing hand-held application device 24 with access to application data from distribution equipment 21.

20 Communications device 27 may be any suitable communications device for communications link 19. Communications device 27 may be, for example, a modem (e.g., any suitable analog or digital modem, cellular modem, or cable modem) such as when communications
25 link 19 is a telephone dial-up link or an Internet link. Communications device 27 may be a network interface card (e.g., an Ethernet card, token ring card, etc.), such as when communications link 19 is a wide-area-network (WAN) link or Internet link.
30 Communications device 27 may be a wireless transceiver (e.g., a radio-frequency or infrared transceiver or other suitable transceiver), such as when communications link 19 is a wireless analog or digital

- 18 -

link, such as a paging-frequency link. A secondary application running on hand-held application device 24 may communicate with user television equipment 22 via a separate communications link 19, or may communicate via
5 communications device 27, distribution equipment 21, and communications link 20 if desired. Application distribution facility 16 may have multiple communications devices 27. One communications device 27 may be used to communicate with hand-held
10 application device 24, and another may be used to communicate with user television equipment 22. Each communications device 27 may be for a different type of link 19 or 20. For example, one communications device 27 may be used to download application data or
15 otherwise exchange access communications over a paging-frequency or 900 MHz link, and another communications device may be used to transmit application data or other information or programming to user television equipment 22 over, for example, a cable television
20 link.

FIGS. 2c and 2d shows additional illustrative arrangements for interactive television application equipment 17 and hand-held application device 24. In FIG. 2c, the primary application runs partly on user
25 television equipment 22 (e.g., a client application) and partly at application distribution facility 16 on application server 25. In FIG. 2d, the secondary application runs partly on hand-held application device 24 and partly at application distribution facility 16
30 on application server 25. If desired, a combination of the two approaches may be used. Application server 25 may use any suitable combination of hardware and software to provide a client-server based primary or

- 19 -

secondary application. Application server 25 may, for example, run a suitable database engine (e.g., SQL Server by Microsoft) and provide interactive television application data in response to queries generated by a primary application client implemented on user television equipment 22. If desired, application server 25 may be located at main facility 12, or some other location, such as television distribution facility 29.

10 The primary and secondary applications in these approaches may retrieve interactive television application data from application server 25 using any suitable client-server based approach. The application may, for example, pass SQL requests as messages to application server 25. In another suitable approach, the application may invoke remote procedures that reside on application server 25 using one or more remote procedure calls. Application server 25 may execute SQL statements for such invoked remote procedures. In still another suitable approach, client objects executed by the application may communicate with server objects executed by application server 25 using, for example, an object request broker (ORB). This may involve using, for example, Microsoft's Distributed Component Object Model (DCOM) approach.

25 The primary and secondary applications may communicate with application server 25 over communications link 20 or 19 using any suitable network and transport layer protocols, if desired. They may communicate, for example, using a protocol stack which includes Sequenced Packet Exchange/Internetwork Packet Exchange (SPX/IPX) layers, Transmission Control Protocol/Internet Protocol (TCP/IP) layers, AppleTalk

- 20 -

Transaction Protocol/Datagram Delivery Protocol (ATP/DDP) layers, WAP, DOCSIS or any other suitable network and transport layer protocols.

FIGS. 2e and 2f show illustrative Internet based interactive television application systems. Application distribution facility 16 may, for example, include Internet service system 61. Internet service system 61 may use any suitable combination of hardware and software capable of providing interactive television application data to the primary or secondary application using an Internet based approach (e.g., using the HyperText Transfer Protocol (HTTP) over a Transmission Control Protocol/Internet Protocol (TCP/IP) type link). If desired, Internet service system 61 may be located at a facility that is separate from application distribution facility 16.

If the primary application is implemented on user television equipment 22 of interactive television application equipment 17 as shown in FIG. 2e, Internet service system 61 (or other suitable equipment at application distribution facility 16 that is connected to Internet service system 61) may provide interactive television application data to user television equipment 22 via the Internet, or via application distribution equipment 21 using any suitable Internet-based approach (e.g. using HTTP over a TCP/IP link). If the primary application is a client-server application as shown in FIG. 2e, or if the secondary application is a client-server application that gets data directly from application distribution facility 16, as shown in FIG. 2f, the primary or secondary application may obtain interactive television

- 21 -

application data from Internet service system 61 via an Internet connection on communications link 20 or 19.

An illustrative arrangement for hand-held application device 24 is shown in FIG. 3. Hand-held application device 24 may be any suitable display remote, personal digital assistant (PDA), ebook, or other suitable portable hand-held device. The functionality that hand-held application device 24 may provide to the user may vary depending on its processing circuitry, communications circuitry and memory. It is envisioned that hand-held application device 24 may be a Windows CE compliant or JAVA-based hand-held PDA style device, or may be enabled by any other suitable software operating system for hand-held devices. Hand-held application device 24 may have user interface 52, processing circuitry 54, storage 56, and communications device 58.

User interface 52 may be any suitable input or output device or system, and may include a liquid crystal display (LCD), touch sensitive screen, stylus, voice recognition and synthesis circuitry, microphone, speaker, manual buttons or keys, keyboard, or any other suitable user input or output hardware and software. User interface 52 preferably includes a touch sensitive screen. A touch sensitive screen may simplify navigation within various types of interactive television applications. Fixed-button remote controls of program guide systems, for example, may have as much as four dozen buttons to choose from. The remotes of these systems may be replaced by a touch sensitive screen enabled hand-held application device 24. A touch sensitive screen of hand-held application device 24 need only display those buttons or controls that

- 22 -

apply to the specific screen that the user is viewing or the specific task that the user is performing. In addition, an interface displayed on a touch sensitive screen may change to suit the type of data entry the user is going to perform in the television application. For example, a keyboard may be displayed to provide a user with an opportunity to enter one or more characters, or a number pad may be displayed to simplify numeric entries. User interface 52 may also include suitable handwriting recognition software for running on a hand-held device.

In still another suitable approach, hand-held application device 24 may have a combination of push buttons and displays. The displays may label each push button with text or graphics to indicate to the user the feature associated with a push button. When the user accesses different interactive applications, the displays may change based on the application accessed. When, for example, an interactive wagering application is accessed, two displays may read "bet" and "info." When the user changes applications to, for example, an interactive program guide, the same displays may read "channel up" and "channel down." For each application, pressing a given push button results in performing the indicated feature. Control codes may be downloaded from, for example, user television equipment 22 via a 900 MHz link, to hand-held application device 24 to indicate to hand-held application device 24 the proper labels and features for each push button.

Processing circuitry 54 may include any suitable processor, such as an Intel Pentium[®], AMD, or other microprocessor. Hand-held application device 24 may also have storage 56. Storage 56 may be any

- 23 -

suitable memory or other storage device, such as RAM, ROM, flash memory, or other storage suitable for a hand-held device.

Hand-held application device 24 may also have communications device 58. Communications device 58 may be any device suitable for supporting communications between hand-held application device 24 and user television equipment 22 or interactive television application equipment 17 over link 19. Communications device 58 may be, for example, a communications port (e.g., a serial port, parallel port, universal serial bus (USB) port, etc.), modem (e.g., any suitable analog or digital standard modem or cellular modem), network interface card (e.g., an Ethernet card, token ring card, etc.), wireless transceiver (e.g., an infrared, radio, or other suitable analog or digital transceiver), or other suitable communications device for a hand-held device. In particular, communications device 58 may be a paging-frequency transceiver. If desired, hand-held application device 24 may have multiple communications devices 58. One communications device 58 may be used to communicate with application distribution facility 16, and another may be used to communicate with user television equipment 22. Each communications device 58 may be for a different type of link 19. For example, one communications device 58 may be used to download application data or otherwise exchange access communications over a paging-frequency or 900 MHz link, and another communications device, such as an infra-red emitter, may be used to control user television equipment 22 and other home entertainment equipment using infra-red controls. The paging-frequency emitter may be used, for example, to

- 24 -

upload device type information and download infra-red codes. When used in this mode, keys may be displayed on the device, and the user may touch the screen to generate commands. The keys can be context sensitive,
5 where only the keys of interest are displayed at any time.

In operation, hand-held application device obtains user commands from user interface 52, processes the commands using processing circuitry 54, and outputs
10 a suitable display screen to the user on user interface 52. When a user indicates a desire to access a function of the secondary application that requires the application to obtain application data, processing circuitry 54 may direct communications device 58 to
15 initiate a session with user television equipment 22 or application distribution facility 16.

The hand-held application device may be of a size to fit in a pocket or purse. The device may have a touch-screen LCD display, a two-way paging interface,
20 and may run on standard batteries. The paging interface may continuously collect TV listing data and store the data in local memory. It may also download advertisements while the device is in normal use. This may be done by for example buying time from a national
25 paging service.

The device may have a fold-down cover to protect the display from damage or accidental activation. Opening the cover automatically may turn the device on and activate its display. The first
30 display may be, for example, a main menu, which may include interactive advertisements. One of the items on the menu may be an interactive program guide. Selecting the guide feature may bring up a guide main

- 25 -

menu, display of program listings or any other suitable
guide display. When a user select a listing, the
device may display a description of a program
associated with the listing. Advertisements may be
5 programming related, in which case selecting them may
bring up more information about a program, allow
reminders to be set, or any other suitable function.
Advertisements for other products may allow a user to
get more information or purchase a product.

10 The hand-held application device may be
offered to consumers for free or for a very low cost,
as it may be advertising supported. Screens or pages
displayed by the device may contain passive or
interactive advertisements. Providing the device at
15 low consumer price may allow the device to be
distributed in large volumes. This may increase the
value of the device to advertisers. Users of the
device may not have to live in a special area,
subscribe to any kind of digital cable or satellite
20 service, or have an Internet account, to use the device
if desired. Once a platform like this has been
distributed, there will be continued opportunities for
growth. New software can be downloaded. It can
support future marketing opportunities, and it offers
25 the ability to add user features at a later date, as
either a free or pay upgrade.

An illustrative arrangement for user
television equipment 22 is shown in FIG. 4. User
television equipment 22 of FIG. 4 receives analog video
30 or a digital video stream from a distribution facility
at input 26. Data from application distribution
facility 16 is also received at input 26. During
normal television viewing, the user tunes set-top

- 26 -

box 28 to a desired television channel (analog or digital). The signal for that television channel is then provided at video output 30. The signal supplied at output 30 is typically either a radio-frequency (RF) signal on a predefined channel (e.g., channel 3 or 4), or a analog demodulated video signal, but may also be a digital signal provided to television 36 on an appropriate digital bus (e.g., a bus using the Institute of Electrical and Electronics Engineers (IEEE) 1394 standard, (not shown)). The video signal at output 30 is received by optional secondary storage device 32.

A primary application or primary application client may run on set-top box 28, on television 36, on optional digital storage device 31 (if television 36 or optional digital storage device 31 has suitable processing circuitry and memory), or on a suitable analog or digital receiver connected to television 36. The interactive television application may also run cooperatively on both television 36 and set-top box 28. Interactive television application systems in which a cooperative interactive television program guide application runs on multiple devices are described, for example, in Ellis U.S. patent application Serial No. 09/186,598, filed November 5, 1998, which is hereby incorporated by reference herein in its entirety.

Secondary storage device 32 can be any suitable type of analog or digital program storage device or player (e.g., a videocassette recorder, a digital versatile disc (DVD) player, etc.). Program recording and other features may be controlled by set-top box 28 using control link 34. If secondary storage device 32 is a videocassette recorder, for

- 27 -

example, a typical control link 34 involves the use of an infrared transmitter coupled to the infrared receiver in the videocassette recorder that normally accepts commands from a remote control such as remote control 40.

Hand-held application device 24 may be used to control set-top box 28, secondary storage device 32, and television 36. Hand-held application device 24 may, for example, have different operation modes for operating as an interface to applications and for controlling user television equipment 22 like a remote control. Hand-held application device 24 may be programmable based on, for example, the devices in user television equipment 22. The user may, for example, select device types from within a suitable setup display. In another suitable approach, hand-held application device 24 may download configuration information from an application (e.g., an interactive television program guide) running on user television equipment 22. Any other suitable approach may also be used.

If desired, the user may record programs, application data, or a suitable combination thereof in digital form on optional digital storage device 31. The user may also download software to digital storage device 31 from the Internet or some other medium. Digital storage device 31 may be a writeable optical storage device (such as a DVD player capable of handling recordable DVD discs), a magnetic storage device (such as a disk drive or digital tape), or any other digital storage device. Interactive television application systems in which program guides have digital storage devices are described, for example, in

- 28 -

Hassell et al. U.S. patent application Serial No. 09/157,256, filed September 17, 1998, which is hereby incorporated by reference herein in its entirety.

Digital storage device 31 can be contained in
5 set-top box 28 or it can be an external device
connected to set-top box 28 via an output port and
appropriate interface. If necessary, processing
circuitry in set-top box 28 formats the received video,
audio and data signals into a digital file format.
10 Preferably, the file format is an open file format such
as the Moving Pictures Expert Group (MPEG) MPEG-2
standard or the Moving Joint Photographic Experts Group
(MJPEG) standard. The resulting data is streamed to
digital storage device 31 via an appropriate bus (e.g.,
15 a bus using the Institute Electrical and Electronics
Engineers (IEEE) 1394 standard), and is stored on
digital storage device 31. In another suitable
approach, an MPEG-2 data stream or series of files may
be received from distribution equipment 21 and stored
20 in digital storage device 31. For example, files from
programs recorded by the user using a remote media
server at television distribution facility 29 may be
stored. Such digital files may be played back to the
user when desired.

25 Television 36 receives video signals from
secondary storage device 32 via communications path 38.
The video signals on communications path 38 may either
be generated by secondary storage device 32 when
playing back a prerecorded storage medium (e.g., a
30 videocassette or a recordable digital video disc), by
digital storage device 31 when playing back a pre-
recorded digital video (e.g., a video for a program
that was recorded by the user at a media server remote

- 29 -

to or within the user's home), may be passed through from set-top box 28, may be provided directly to television 36 via set-top box 28 if secondary storage device 32 is not included in user television equipment 5 22, or may be received directly by television 36. During normal television viewing, the video signals provided to television 36 correspond to the desired channel to which the user has tuned with set-top box 28. Video signals may also be provided to television 10 36 by set-top box 28 when set-top box 28 is used to play back information stored on digital storage device 31, or when set-top box 28 is used to decode a digital video stream, or digital files transmitted from television distribution facility 29.

15 Set-top box 28 may have communications device 37 for communicating directly with application server 25 or Internet service system 61 over communications link 20, or with hand-held application device 24 over communications link 19. Communications 20 device 37 may be, for example, a communications port (e.g., a serial port, parallel port, universal serial bus (USB) port, etc.), modem (e.g., any suitable analog or digital standard modem or cellular modem), network interface card (e.g., an Ethernet card, token ring 25 card, etc.), wireless transceiver (e.g., an infrared, radio, or other suitable analog or digital transceiver), or other suitable communications device. Television 36 may also have such a suitable communications device if desired. In particular, 30 communications device 37 may be a paging-frequency or 900 MHz transceiver. If desired, set-top box 28 may have multiple communications devices 37. One communications device 37 may be used to communicate

- 30 -

with application distribution facility 16, and another
may be used to communicate with hand-held application
device 24. Each communications device 37 may be for a
different type of link 20. For example, one
5 communications device 37 may be used to download
application data or otherwise exchange access
communications over a paging-frequency or 900 MHz link,
and another communications device may be used to
control user television equipment 22 using infra-red
10 controls.

A more generalized embodiment of user
television equipment 22 of FIG. 4 is shown in FIG. 5.
As shown in FIG. 5, interactive application data from
application distribution facility 16 (FIG. 1) is
15 received by control circuitry 42 of user television
equipment 22. The functions of control circuitry 42
may be provided using the set-top box arrangement of
FIG. 4. Alternatively, these functions may be
integrated into an advanced television receiver (e.g.,
20 a digital television receiver or high definition
television (HDTV) receiver), personal computer
television (PC/TV), or any other suitable arrangement.
If desired, a combination of such arrangements may be
used.

25 User television equipment 22 of FIG. 5 may
have secondary storage device 47; digital storage
device 49, or any suitable combination thereof for
recording programming. Secondary storage device 47 and
digital storage device 49 may be omitted if desired.
30 Secondary storage device 47 can be any suitable type of
analog or digital program storage device (e.g., a
videocassette recorder, a digital versatile disc (DVD),
etc.). Program recording and other features may be

- 31 -

controlled by control circuitry 42. Digital storage device 49 may be, for example, a writable optical storage device (such as a DVD player capable of handling recordable DVD discs), a magnetic storage device (such as a disk drive or digital tape), or any other digital storage device.

Memory 63 may be any memory or other storage device, such as a random access memory (RAM), read only memory (ROM), flash memory, a hard disk drive, a combination of such devices, etc., that is suitable for storing primary application instructions and application data for use by control circuitry 42.

User television equipment 22 of FIG. 5 may have communications device 51 for supporting communications between user television equipment 22 and application server 25 or Internet service system 61 via communications link 20, or between hand-held application device 24 via communications link 19. Communications device 51 may be, for example, a communications port (e.g., a serial port, parallel port, universal serial bus (USB) port, etc.), modem (e.g., any suitable analog or digital standard modem or cellular modem), network interface card (e.g., an Ethernet card, token ring card, etc.), wireless transceiver (e.g., an infrared, radio, or other suitable analog or digital transceiver), or other suitable communications device. In particular, communications device 51 may be a paging-frequency or 900 MHz transceiver. If desired, user television equipment 22 may have multiple communications devices 51. One communications device 51 may be used to communicate with application distribution facility 16, and another may be used to communicate with hand-held

- 32 -

application device 24. Each communications device 37 may be for a different type of link 20. For example, one communications device 51 may be used to download application data or otherwise exchange access
5 communications over a two-way cable link, paging-frequency or 900 MHz link, and another communications device may be used to provide television programming, application data, or other information to hand-held application device 24 over an infra-red or 900 MHz
10 link.

The primary and secondary applications may be any suitable application including, without limitation, a home shopping application, web-browser, to-do list, wagering application, or any other application. For
15 clarity, the present invention will be illustrated in connection with a system in which an interactive television program guide application is implemented on interactive television application equipment 17 and hand-held application device 24. In one suitable
20 arrangement for such a system, program guide data is distributed from a main facility to an interactive television program guide implemented on user television equipment via an application distribution facility. In another suitable arrangement, the interactive
25 television program guide application may be implemented using a client-server architecture in which the primary processing power for the application is provided by a server located at, for example, application distribution facility 16 or main facility 12 (e.g.,
30 program guide server 25), and user television equipment 22 acts as a client processor as illustrated by FIGS. 2c and 2d. In still another alternative arrangement, the program guide application may obtain

- 33 -

program guide data from the Internet, as illustrated by FIGS. 2e and 2f.

Program guides typically limit a user's ability to select interactive objects on a screen by
5 requiring that objects be selected by positioning a highlight region or cursor over the objects. When, for example, a user is within a column of program listings, the user cannot arrow above or below the column to select an interactive object. In addition, the user
10 may be required to perform several key strokes to navigate from one object to another. On a touch sensitive screens such as the preferred display of hand-held application device 24, however, any area can be selectable, thereby providing the user with an
15 increased ability to access interactive objects. Hand-held application device 24 may, for example, display a menu modeled after a menu displayed on user television equipment 22 by an interactive application. The user may select a particular menu option with a single
20 action without having to perform, as with a regular remote control, multiple keystrokes to position a highlight region.

The portable hand-held application device may include many of the features of interactive program
25 guides, such as listings by time, by channel, by category, favorite channels or any other guide feature. It may allow the user to set reminders and have them appear on the device, with both an audio alert and a display. Via a paging return, for example, the device
30 can be used to set reminders or schedule recordings remotely. The portable device may be used for collecting data. For example, it might be used to send out surveys. It may also be used to collect audience

- 34 -

ratings information. With an appropriate point-of-purchase device, for example, may be used to distribute electronic coupons.

A secondary program guide running on hand-held device 24 may obtain program guide data directly from application distribution facility 16 (e.g., distribution equipment 21, application server 25, or Internet service system 61), from a primary program guide application running on user television equipment 22, or using a combination of these approaches. Whatever the approach used, the secondary program guide application running on hand-held application device 24 may provide a user with an opportunity to coordinate the functions of the primary guide with the functions of the secondary guide, thereby extending the interactivity of the primary and secondary guides.

The display of hand-held application device 24, preferably a touch sensitive screen, becomes an integrated part of the on-screen guide. Complimentary interactivity between the primary and secondary guides may be provided for various program guide functions without interrupting television viewing. For example, browsing through channels and times, accessing program information, ordering pay-per-view programs, setting reminders, and locking programs may all be performed by the user with hand-held application device 24. For more user-involved functions such as setting favorite channels, viewing more than one channel at a time, or setting global parental locks, the display of hand-held application device 24 may seamlessly convert to a remote control that allows the user to navigate a primary guide display screen to perform the function. Hand-held applications device 24 may provide stand-

- 35 -

alone access to program guide or other interactive television application features if desired.

FIG. 6 shows an illustrative menu screen 601 that may be displayed by hand-held application device 24 when, for example, device 24 starts up. Menu screen 601 may include a number of icons 603 that indicate secondary applications that have functionality coordinated with primary applications running on user television equipment 22. Menu screen 601 may also include icons 605 that indicate other applications that run exclusively on hand-held application device 24, if desirable. A user may access a secondary program guide application by, for example, touching a TV Guide icon with his or her finger or stylus.

FIG. 7 shows an illustrative browse display screen 701 that may be displayed by the secondary program guide running on hand-held access device 24. Browse display screen 701 may be displayed, for example, on startup, or after the user selects a suitable icon from menu screen 601. Browse display screen 701 may include browse area 703 in which a program title 715 for the browsed channel 717 and time slot 719 is displayed. Browse area 703 may also include the broadcast time of the program associated with the listing, and its rating. The current time 711 and channel 713 may also be displayed.

A user may browse program listings for other time slots and channels by touching right, left, up, and down arrows 721. A user may tune to the browsed channel by, for example, touching channel 717. When a user touches channel 717, the secondary program guide may exchange one or more application communications with the primary guide via communications link 19

- 36 -

telling the primary guide that the user has indicated a desire to tune to a particular channel. The primary guide may cause user television equipment 22 to tune to the indicated channel. In another suitable approach, 5 hand-held application device 24 may be programmed to change the channel on television 36 using set-top box 28 (FIG. 4).

The controls in browse display screen 701 may also be used to perform any other suitable function. 10 The user may touch time 719 or channel 717 to, for example, enter a by-time or by-channel listings screen. In still another suitable approach, the user may touch time 719 and hand-held application device 24 may present a numeric keypad or a list of times separated 15 by, for example, one-half hour time slots, to provide the user with an opportunity to indicate a time for which the user wishes to browse listings. In response to the user touching channel 717, hand-held application device 24 may present a numeric keypad or a list of 20 channels to provide the user with an opportunity to indicate a channel for which the user wishes to browse listings.

Browse display screen 701 may include selectable advertisements 705. Selectable 25 advertisements 705 may, for example, include text and graphics advertising a program or other television or non-television products or services. When a user selects a selectable advertisement 705, the secondary guide may display information (e.g., pay-per-view 30 ordering information, program information, etc.) or take other actions related to the content of the advertisement. The secondary guide may, for example, cause user television equipment 22 to tune to a barker

- 37 -

type channel on which a trailer for an advertised pay-per-view program is displayed. Alternatively, the secondary guide may use one or more application communications to indicate to the primary guide that the user has selected an advertised for a pay-per-view program. The primary guide may then tune user television equipment 22 to the associated barker channel. While the barker channel is being played on user television equipment 22, the secondary guide may provide a user with an opportunity to order the pay-per-view program.

Browse display screen 701 may also include logo 707 for providing a user with an opportunity to access the primary program guide running on interactive television application equipment 17. The user may touch exit icon 709 to return hand-held application device 24 to its default state (e.g., power it down, return to main menu screen 601, etc.). If desired, browse display screen 701 may include other controls suitable for browsing listings. Browse display screen 701 may include, for example, next program, previous program, hour ahead, hour back, day ahead, day back, and current time controls. When selecting channels, browse display screen 701 may include, for example, next and previous favorites buttons to allow the user to indicate a desire to browse listings for favorite programs. Any other suitable control may also be used.

FIG. 8 shows an illustrative information screen 801 that the secondary program guide may display when, for example, the user touches a program title 715 from browse display screen 701 of FIG. 7, or when the user selects a selectable advertisement 705. Information screen 801 may include information 803

- 38 -

about the program indicated by the selected listing. Information screen 801 may also include selectable advertisements 705, the current time 711, the current channel 713, logo 707, and exit icon 709. When the user accesses information screen 801 by selecting a selectable advertisement 705, only the selected selectable advertisement may remain on the screen. The secondary program guide may provide a user with an opportunity to access other familiar program guide features for the indicated program from information screen 801, such as tuning to the program (by touching watch control 807).

The secondary guide may provide a user with an opportunity to set reminders. The user may set a reminder for the indicated program by, for example, touching remind control 809. When the user sets a reminder using hand-held application device 24, the secondary guide may coordinate the reminder with the primary guide. The secondary guide may, for example, indicate the program for which the reminder is set to the primary guide by exchanging one or more application communications via link 19. At an appropriate time (e.g., ten minutes before the program starts), the secondary guide may display a reminder on hand-held access device 24 and the primary guide may display a reminder on display device 45 (FIG. 5). To conserve memory on hand-held application device 24, reminders may be set by the secondary guide with the primary guide and not stored by the secondary guide. When the reminder is displayed by the primary guide, the primary guide may exchange one or more application communications with the secondary guide indicating that

- 39 -

a reminder is due for a given program. The secondary guide may display a reminder accordingly.

Hand-held application device 24 may provide the user with an opportunity to configure the time at which a reminder is displayed. The user may schedule reminders for, for example, between one and fifteen minutes before a program is available. If desired, reminders may be provided by hand-held application device 24 and user television equipment 22 at different default or user-configured times. In still another approach, reminders may be provided by only one of hand-held application device 24 and user television equipment 22.

The secondary guide may provide a user with an opportunity to parentally lock or unlock program titles, channels, ratings, or time periods. The user may indicate a desire to parentally lock an indicated program or one of its attributes (e.g., title, rating, channel, etc.) by, for example, touching lock control 811. Locking or unlocking a program title, channel, rating, or time period may be an involved function in some program guides from a user interaction standpoint. When a user indicates a desire to lock or unlock a program title, channel, rating, or time period the secondary program guide may exchange one or more application communications with the primary program guide that indicate to the primary guide that the user wishes to lock or unlock a given program title, channel, rating, or time period. The secondary guide may then convert to a remote control that allows the user to navigate within a primary guide parental control display screen. In guides where parentally controlling a program is not very involved, the

- 40 -

secondary guide may provide the user with an opportunity to lock or unlock a program by title, channel, genre, rating, or example.

The secondary guide may also provide a user
5 with an opportunity to change a parental control code. When a user changes a parental control code, the secondary guide may indicate to the primary guide the changing of the code and the new code, using one or more application communications. The primary guide may
10 then change the parental control code accordingly.

If desired, information screen 801 may include a more control in addition to or instead of controls 807, 809, and 811. In response to a user touching a more control, hand-held application device
15 24 may provide controls for additional features. Additional controls may include, for example, pay-per-view ordering controls, other air time controls, or any other suitable control.

The secondary guide running on hand-held
20 application device 24 may provide a user with an opportunity to order pay-per-view programs. A user may indicate a desire to order a pay-per-view program by, for example, touching a selectable advertisement 705 that advertises a pay-per-view program. FIG. 9 shows
25 an illustrative pay-per-view ordering screen. As with other display screens displayed by the secondary guide on hand-held application device 24, pay-per-view ordering screen may include brand logo 707, exit control 709, the current time 711, and current channel
30 713. Pay-per-view ordering screen 901 may also include ordering information 907. Ordering information 907 may include the title of the selected program, the air time 911 for the selected showing, the price, a brief

- 41 -

description, the rating of the pay-per-view program, and any other suitable information.

Pay-per-view ordering screen 901 may also include selectable advertisements 705. A single
5 selectable advertisement 705 may be displayed when, for example, the user accesses a pay-per-view ordering screen by selecting a selectable advertisement. The single selectable advertisement may not be actionable. When the user accesses the screen by, for example,
10 selecting a pay-per-view program title, two selectable advertisements 705 may be displayed. When a user selects one of the two selectable advertisements 705, the secondary guide may display a program information screen for an advertised program.

15 When screen 901 is initially displayed, run time 911 for the indicated pay-per-view program may start at the next available start time 913. The user may see additional air times by, for example, touching left arrow 903 or right arrow 905. When the user
20 selects a different start time 913, the secondary guide may display ordering information 907 for the selected start time.

The secondary guide may provide a user with an opportunity to navigate within the primary guide and
25 access features of the primary guide using hand-held application device 24. A user may indicate a desire to access the primary guide by, for example, touching logo 707. FIG. 10 shows an illustrative remote screen 1000. Remote screen 1000 may include, for example, logo 707,
30 selectable advertisements 705, current time 711 and current channel 713. When a user selects logo 707 from within remote screen 1000, the secondary guide may instruct the primary guide to display a program

- 42 -

listings screen on display device 54 (FIG. 5). The controls of remote screen 1000 may be based on and displayed according to the screen displayed by a primary guide or other application, the option
5 highlighted on a particular primary application screen, the content or type of information displayed in a primary application screen, or any other suitable feature, group of features, or content.

The user may navigate within a primary guide
10 display screen by, for example, touching arrows 1003. Navigation within a program guide display screen using hand-held application device may be performed within any primary guide display screen. For the purposes of illustration, navigation within a primary guide main
15 menu screen and within a primary guide program listings screen is discussed.

An illustrative primary guide main menu screen 100 is shown in FIG. 11. Main menu screen 100 may include menu 102 of selectable program guide
20 features 106. If desired, program guide features 106 may be organized according to feature type. In menu 102, for example, program guide features 106 have been organized into three columns. The column labeled "TV GUIDE" is for listings related features, the column
25 labeled "MSO SHOWCASE" is for multiple system operator (MSO) related features, and the column labeled "VIEWER SERVICES" is for viewer related features. The interactive television program guide may generate a display screen for a particular program guide feature
30 when a user selects that feature from menu 102.

Main menu screen 100 may include one or more selectable advertisements 108. Selectable advertisements 108 may, for example, include text and

- 43 -

graphics advertising pay-per-view programs or other programs or products. When a user selects a selectable advertisement 108, the program guide may display information (e.g., pay-per-view information) or take
5 other actions related to the content of the advertisement. Pure text advertisements may be presented, if desired, as illustrated by selectable advertisement banner 110.

Main menu screen 100 may also include other
10 screen elements. The brand of the program guide product may be indicated, for example, using a product brand logo graphic such as product brand logo graphic 112. The identity of the television service provider may be presented, for example, using a service
15 provider logo graphic such as service provider logo graphic 114. The current time may be displayed in clock display region 116. In addition, a suitable indicator such as indicator graphic 118 may be used to indicate to a user that mail from a cable operator is
20 waiting for a user if the program guide supports messaging functions. Additionally a TV e-mail reminder may allow a user to know when he or she has awaiting e-mail messages from an Internet, Intranet or other computer-related e-mail account. The user may
25 interactively correspond with his or her e-mail respondent using, for example, a virtual keyboard displayed on hand-held application device 24, voice commands that are received and processed by hand-held application device 24, or a suitable input device
30 connected to hand-held application device 24 or user television equipment 22 (e.g., a wireless keyboard).

A user may select a feature 106 by, for example, positioning highlight region 120 over the

- 44 -

feature. The user may position highlight region 120 by, for example, touching arrows 1003. As the user touches an arrow 1003, the secondary guide may indicate the desired action (i.e., positioning highlight region 5 120) to the primary guide using one or more application communications. The primary guide may receive the application communications and position highlight region 120 on display device 45 accordingly.

When the user has positioned highlight region 10 120 over a desired feature, the user may select the feature by, for example, touching OK 1005 on hand-held application device 24. The secondary guide may indicate to the primary guide that the user has selected a feature using one or more application 15 communications. The primary guide may receive the application communications and perform the desired function.

A user may, for example, desire to view program listings using the primary guide by, for 20 example, selecting a "By Time" feature. Alternatively, the user may indicate a desire to view program listings by, for example, selecting a by-time option from within primary guide main menu screen 100. The secondary guide may indicate the desired feature to the primary 25 guide using one or more application communications, and the primary guide may display a program listings screen.

The primary guide may overlay a program listings screen over a program being viewed by a user 30 or over a portion of the program in a "browse" mode. Program listings may be displayed using any suitable list, table, grid, or other suitable display arrangement. If desired, program listings screens may

- 45 -

include selectable advertisements, product brand logo graphics, service provider brand graphics, clocks, or any other suitable indicator or graphic.

FIG. 12 illustrates the display of program listings by time. Program listings screen 130 of FIG. 12 may include highlight region 151, which highlights the current program listing 150. A user may position highlight region 151 by, for example, touching arrows 1003. A user may tune to a program by, for example, highlighting its listing and touching "OK" 1005. A user may view additional listings for the time slot indicated in time bar 111 by, for example, touching arrows 1003 to move highlight region 120 up or down past the beginning or end of the listings. A user may view program listings for other time slots by, for example, touching right and left arrows 1003. In this example, hand-held application device may include other controls appropriate for program listings screen 130, such as page up, page down, day forward, day back, or any other suitable control.

The secondary program guide may provide a user with an opportunity to navigate within the primary program guide in other ways. The secondary guide may provide a user with an opportunity to set channels as favorites on the secondary guide, the primary guide, or both. The user may, for example, navigate between listings set as favorites by touching "FAV" 1007. Alternatively, the secondary guide may re-sort program listings with the favorite channels in the most prominent or convenient position as displayed on hand-held application device 24 or user television equipment 22.

- 46 -

The user may back up one previous primary guide display screen by, for example, touching "LAST" 1009. The user may return to primary guide main menu screen 100 by, for example, touching "MENU" 1011. The user may return to watching television by, for example, touching "EXIT" 709. A user may indicate a desire to view program information for a particular listing by, for example, positioning highlight region 150 over the listing and touching "INFO" 1013. Other illustrative controls that may be displayed by the secondary guide on hand-held application device 24 when a user highlights a program listing from within a listings screen or other display screen may include controls for: setting a reminder, locking a program, ordering the program if it is a pay-per-view, seeing other air times of the program, or ordering program-related merchandise such as a CD of the soundtrack, a videotape of the program, or apparel carrying the program's brand.

The primary guide may also provide a user with an opportunity to view a listing of channels such as shown in illustrative premiums screen 231 of FIG. 13. The secondary guide may change the display on hand-held application device to display controls that are suitable for such a screen. The secondary guide may display, for example, a subscribe control for subscribing to a channel, a set favorite control to set a channel as a favorite, a lock control to lock a channel, or an info control for providing information about a channel.

The secondary guide may also provide a user with an opportunity to define what objects are always displayed on hand-held application device 24. The user

- 47 -

may choose, for example, a help control that invokes context sensitive help, a message flag that signals hand-held application device 24 or the user's television equipment has received an e-mail, a VCR
5 button, a DVD button, or a power off button that turns off all of user television equipment 22 and devices connected to user television equipment 22.

The functionality of the primary guide may be extended to or coordinated with the secondary guide for
10 any number of other suitable program guide related features. The secondary guide may provide a user with an opportunity to use hand-held application device 24 to, for example: send and receive e-mail (related to the guide, such as promotional messages from the cable
15 operator, or unrelated to the guide, such as personal messages); buy merchandise; bid on a televised auction; order subscriptions services such as HBO; pay a cable bill; make a financial transaction for someone at a different household (such as renting a PPV movie for
20 another, or making any other guide-based financial transaction); effect Internet based e-commerce (e.g., order merchandise, participate in an on-line auction or reverse auction, etc.), or surf the Internet. These and other features may be incorporated into hand-held
25 access device 24 as a stand-alone device if desired.

Another function that may be coordinated between the primary and secondary guides using hand-held application device 24 is the control of a picture-in-picture (PIP) display. A PIP display is a small
30 partial-screen video window of one channel's video overlaid on top of another channel's video that is displayed full-screen. Using the browse function of the secondary guide, the user could browse channels and

- 48 -

program titles on hand-held application device 24 and watch the same channels in the PIP, while other viewers can continue to watch the tuned channel on the main screen. The secondary guide may also provide a user
5 with an opportunity to call up on-demand movie trailers, TV commercials and other downloaded video within the PIP window, using hand-held application device 24.

The secondary guide (or other software
10 running on hand-held application device 24) may also provide a user with an opportunity to control the PIP in multi-person video conferencing. For example, in a three-way video conference the user could switch views between the two other user locations by touching
15 suitable controls on hand-held application device 24. In a two-way video conference, for example, the user may use hand-held application device 24 to alternate between viewer locations in the PIP display.

Hand-held application device 24 may have
20 suitable processing circuitry so as to display video. A video signal may be streamed, for example, as an MPEG-2 data stream to hand-held application device 24 for display. Video displays may also be streamed to hand-held application device 24 as a user browses
25 through program listings using the secondary guide. In this approach, the video display may include video for a program that has its listing displayed and that is being broadcasted at the time of the browse. If system resources do not permit the streaming of video, still
30 shots may be transmitted from interactive television application equipment 17 to hand-held application device 24 for display instead. In another suitable approach, highly compressed videos may be used to

- 49 -

account for bandwidth constraints. Using highly compressed videos may also be desirable when, for example, the resolution of the display of hand-held application device 24 would not support high-resolution video.

Other applications may be exclusively run on hand-held application device 24. Hand-held application device 24 may run, for example, an on-line program guide client. A user may indicate a desire to access an on-line program guide by, for example, touching TV Guide On-line from menu screen 601 (FIG. 6). When a user indicates a desire to access an on-line program guide, hand-held application device 24 may launch a standard Internet browser and access a suitable Web site. Alternatively, a proprietary Web browser or other remote access software may be launched in order to access a Web site or other proprietary site that provides Web access for a hand-held device.

FIG. 14 shows an illustrative home page for a hand-held access device Web site. When a user selects a HyperText link or other suitable type of anchor, hand-held access device 24 may download a HyperText Markup Language (HTML) page using the HyperText Transfer Protocol (HTTP). Any other suitable protocol may be used. In still another suitable approach, hand-held access device 24 may use suitable remote access software such as a Windows remote access software (RAS) client to download screen shots or screen shot commands, from a server (i.e., an Internet server that provides Internet access via a remote access client). FIG. 15 shows an illustrative page that hand-held access device 24 may display when, for example, a user selects a "Editor's Picks" anchor.

- 50 -

FIGS. 16a and 16b show illustrative pages that hand-held application device 24 may display when, for example, a user selects My TV listings anchor 1403. As shown, the on-line guide client, Web browser, or
5 other access application running on hand-held application device 24 may provide a user with an opportunity to view program listings sorted according to one of a number of user selected criteria. When a user selects criteria, the on-line guide client, Web
10 browser, or other Internet access application may retrieve program listings for the selected criteria and display the listings as shown in FIG. 16c. If desired, program listings may be downloaded based on the user's zip code, cable system, satellite service, or other
15 suitable criteria, so that the user views program listings for programs available to the user and for the proper time zone. Users may also be provided with an opportunity to limit the listings by time, genre, favorites, or any other suitable criteria.

20 The on-line guide client, Web browser, or other access application running on hand-held application device 24 may also provide a user with an opportunity to view information about the application. FIG. 17 shows an about page that hand-held application
25 device 24 may display when, for example, a user selects an About TVG Wireless anchor 1403, or other suitable anchor, from home page 1401 of FIG. 14.

FIGS. 18-20 are flowcharts of illustrative steps involved in providing stand-alone and coordinated
30 application features on hand-held application device 24. The steps shown in FIGS. 18-20 are illustrative and in practice may be performed in any suitable order. FIG. 18 is a flowchart of illustrative steps involved

- 51 -

in providing interactive television and other application features with hand-held application device 24. At step 1800, application data, such as interactive television application data or data for other applications, is provided to hand-held application device 24. The data may be provided directly from main facility 12 to hand-held application device 24, from main facility 12 to hand-held application device 24 via interactive television application equipment 17, or directly from interactive television application equipment 17 (i.e., data that originates from interactive television application equipment 17). The interactive television application data may include any data suitable for interactive television or other applications. Interactive television applications may include, for example, applications that provide information related to television programming or that provide interactive features associated with television programming, such as, for example, interactive television program guides, home shopping applications, e-mail, wagering and financial trading applications. Interactive television applications may also include applications provided on user television equipment 22. As illustrative examples, home shopping applications and financial trading applications may be interactive television applications when features of such applications are provided via user television equipment. The features of these applications may be provided with television programming related to the features. A home shopping application may, for example, provide purchasing opportunities for products and services featured on a home shopping television channel.

- 52 -

Hand-held application device 24 receives the interactive television application data (step 1810) and provides a user with an opportunity to access the television related application with hand-held access device 24 (step 1820). The interactive television application may run as a stand alone application, as a client that requests data from a server (e.g., a server at main facility 12 or interactive television application equipment 17), or cooperatively with a primary application running within interactive television application equipment 17. At step 1830, hand-held application device 24 may provide the user with an opportunity to access other applications such as, for example, PDA-type functions. For example, it may support e-mail, a calendar, a contact list, web browsing, a calculator, etc. It may support data services, such as news, weather, sports, traffic, or any other suitable data service. Such applications may also be provided as stand alone or server applications running on user television equipment 22 and accessible by hand-held application device 24. Hand-held application device 24 may be used as a pager. With suitable hardware resources, the portable program guide might include advanced communication functions. For example, it might allow a user to remotely monitor the home equipment -- find out if the system is turned on, what channel is on, etc. It might also allow a user to listen to audio from a selected TV channel, or offer audio channels.

FIG. 19 is a flowchart of illustrative steps involved in coordinating features between primary applications running within interactive television application equipment 17 and supplemental applications

- 53 -

running on hand-held access device 24. At step 1900, main facility 12 or interactive television application equipment 17 provides application data to a primary application running on interactive television

5 application equipment 17. The primary application may be an interactive television application or not related to television programming. At step 1910, the primary application provides the application data to a secondary application running on hand-held access

10 device 24 using, for example, one or more access communications. At step 1920, the secondary application running on hand-held application device 24 provides a display of interface controls that are coordinated with the features of the primary

15 application. For example, the interface controls may correspond with navigational features of the primary application. The illustrative remote screen 1000 of FIG. 10, for example, includes navigational arrows 1003 to correspond to navigational features of an

20 interactive television program guide running on user television equipment 22. The user interface also includes controls for interactive guide features, such as favorites, last, more information, and menu. In a home shopping application, for example, user interface

25 controls may include similar navigational controls, and may include other controls for home shopping features such as purchasing, information, putting items on wish lists, or any other suitable home shopping feature. In a home stock trading application for example, user

30 interface controls may include similar navigational controls and may include other controls for features such as buying stocks, selling stocks, more information, or any other suitable feature. In a web

- 54 -

browser application, for example, similar navigational controls and other controls for, for example, back, forward, home, bookmark, or any other suitable feature may be provided. In a wagering application, for
5 example, user interface controls may be provided for wagering, providing additional information regarding wagering opportunities, or any other suitable feature.

The interface controls may be coordinated with the features of the secondary application using
10 the data provided by the primary application. In this way, user interface controls may be dynamically configurable based on the primary application. If desired, a library of standard controls may be stored by hand-held application device 24 so that the user is
15 provided with a consistent interface across primary applications. Controls that are specialized for particular primary applications may be downloaded if desired.

Another example of coordinating interface
20 controls with features of a primary application is providing primary application content on hand-held application device 24. In an interactive program guide application, for example, hand-held access device 24 may display television programming when, for example,
25 the user browses listings while watching a program on user television equipment 22.

At step 1930, the secondary application controls the functionality of the primary application based on the user controls selected by the user as
30 indicated on hand-held application device 24. This may be accomplished by, for example, exchanging one or more access communications with the primary application. In the example of FIG. 10, the user may select an arrow

- 55 -

1003 to position highlight region 120 or 151 of FIGS.
11 and 12. In a home shopping application, for
example, the primary application may initiate a
purchase sequence in response to a user selecting a
5 purchase control on hand-held application device 24.
In a stock trading application, for example, the
primary application may sell stock in response to a
user selecting a sell control on hand-held application
device 24. In a web browser, for example, the system
10 may go back to a previously accessed web page in
response to a user selecting a back control.

FIG. 20 is a flowchart of illustrative steps
involved in providing interactive television program
guide functionality using hand-held application device
15 24. At step 2100, program guide data is provided to
hand-held application device 24. The data may be
provided directly from main facility 12 to hand-held
application device 24, from main facility 12 to hand-
held application device 24 via interactive television
20 application equipment 17, or directly from interactive
television equipment 17 (i.e., data that originates
from interactive television application equipment 17).
At step 2110, hand-held application device 24 provides
the user with an opportunity to browse program
25 listings. This may be accomplished independently, as a
client to a primary server application running on a
portion of interactive television application equipment
17, or cooperatively with a primary application running
on a portion of interactive television application
30 equipment 17. Hand-held application device 24 or user
television equipment 22 may provide television
programming in response to the user selecting a browsed
listing (step 2115).

- 56 -

At step 2120, hand-held application device 24 may provide the user with an opportunity to set reminders. Reminders may appear on hand-held access device 24, with both an audio alert and a display 5 (step 2125). Via a paging return, for example, the device can be used to set reminders remotely with an interactive television program guide resident on user television equipment 22.

At step 2130, hand-held application device 24 10 may provide the user with an opportunity to order pay-per-view programs. A user may indicate a desire to order pay-per-view programs by, for example, selecting listings on hand-held application device 24, selecting advertisements on hand-held application device, or by 15 performing any other suitable function. Ordered pay-per-view programs may be provided on hand-held application device 24, or may be provided on user television equipment 22 (step 2135).

At step 2140, hand-held application device 24 20 may provide the user with an opportunity to view additional programming information. A user may indicate a desire to view additional programming information by, for example, selecting a program listing, selecting an advertisement (e.g., as shown in 25 FIG. 9), or by selecting any other suitable control. The additional information may be provided on hand-held application device 24, or may be provided on user television equipment 22 (step 2145).

The foregoing is merely illustrative of the 30 principles of this invention and various modifications can be made by those skilled in the art without departing from the scope and spirit of the invention.

- 57 -

What is claimed is:

1. A method for providing a user with access to an interactive television application with a hand-held application device, comprising:

providing interactive television application data;

receiving the interactive television application data with a hand-held application device having one or more touch-sensitive controls;

providing the user with an opportunity to access the interactive television application data with the hand-held access device using the touch-sensitive controls.

2. The method defined in claim 1 wherein providing interactive television application data comprises providing interactive television application data from a main facility for reception by the hand-held application device.

3. The method defined in claim 1 wherein providing interactive television application data comprises providing interactive television application data from interactive television application equipment for reception by the hand-held application device.

4. The method defined in claim 1 wherein:
the interactive television application is an interactive television program guide;
the interactive television application data includes television program listings; and
providing the user with an opportunity to access the interactive television application data

- 58 -

with the hand-held access device using the touch-sensitive controls comprises providing the user with an opportunity to browse program listings using the touch-sensitive controls.

5. The method defined in claim 4 further comprising providing a television program associated with a browsed program listing on the hand-held application device.

6. The method defined in claim 1 wherein:
the interactive television application is an interactive television program guide;
the interactive television application data includes television program listings; and
providing the user with an opportunity to access the interactive television application data with the hand-held access device using the touch-sensitive controls comprises providing the user with an opportunity to set a reminder using the touch-sensitive controls.

7. The method defined in claim 6 further comprising providing the reminder on the hand-held access device as set by the user.

8. The method defined in claim 1 wherein:
the interactive television application is an interactive television program guide;
the interactive television application data includes television program listings; and
providing the user with an opportunity to access the interactive television application data

- 59 -

with the hand-held access device using the touch-sensitive controls comprises providing the user with an opportunity to order a pay-per-view program using the touch-sensitive controls.

9. The method defined in claim 1 wherein:
the interactive television application is an interactive television program guide;
the interactive television application data includes television program listings and additional programming information; and
providing the user with an opportunity to access the interactive television application data with the hand-held access device using the touch-sensitive controls comprises providing the user with an opportunity to access additional programming information for a television program using the touch-sensitive controls.

10. The method defined in claim 1 further comprising:
receiving the interactive television application data with user television equipment for use by a primary application; and
coordinating the touch-sensitive controls with features of the primary application.

11. The method defined in claim 10 wherein coordinating the touch-sensitive controls with features of the primary application comprises exchanging one or more access communications between the hand-held application device and the user television equipment.

- 60 -

12. The method defined in claim 10 wherein the interactive television application is an interactive television program guide, a home shopping application, a home stock trading application, a home wagering application, or a television-related e-mail application.

13. The method defined in claim 10 further comprising:

providing interactive application data for a non-television application;

receiving the interactive application data with the hand-held application device; and

providing the user with an opportunity to access the interactive application data with the hand-held access device using the touch-sensitive controls.

14. The method defined in claim 13 wherein the interactive application is a calender, contact list, web browser, calculator, or to-do list.

15. The method defined in claim 10 wherein:
the interactive television application is an interactive television program guide;

the interactive television application data includes television program listings;

coordinating the touch-sensitive controls with features of the primary application comprises coordinating the touch-sensitive controls with features of the interactive television program guide; and

- 61 -

providing the user with an opportunity to access the interactive television application data with the hand-held access device using the touch-sensitive controls comprises providing the user with an opportunity to browse program listings using the touch-sensitive controls.

16. The method defined in claim 15 further comprising providing a television program associated with a browsed program listing on the hand-held application device.

17. The method defined in claim 15 further comprising:

providing at least one access communication to the user television equipment wherein the at least one access communication indicates to the user television equipment a browsed program listing; and

providing a television program associated with a browsed program listing on the user television equipment in response to the at least one access communication.

18. The method defined in claim 10 wherein:
the interactive television application is an interactive television program guide;

the interactive television application data includes television program listings;

coordinating the touch-sensitive controls with features of the primary application comprises coordinating the touch-sensitive controls

- 62 -

with features of the interactive television program guide; and

providing the user with an opportunity to access the interactive television application data with the hand-held access device using the touch-sensitive controls comprises providing the user with an opportunity to set a reminder using the touch-sensitive controls.

19. The method defined in claim 18 further comprising providing the reminder on the hand-held access device as set by the user.

20. The method defined in claim 10 wherein:
the interactive television application is an interactive television program guide;

the interactive television application data includes television program listings;

coordinating the touch-sensitive controls with features of the primary application comprises coordinating the touch-sensitive controls with features of the interactive television program guide; and

providing the user with an opportunity to access the interactive television application data with the hand-held access device using the touch-sensitive controls comprises providing the user with an opportunity to order a pay-per-view program using the touch-sensitive controls.

21. The method defined in claim 20 further comprising:

- 63 -

providing at least one access communication to the user television equipment wherein the at least one access communication indicates to the user television equipment a pay-per-view program ordered by the user using the hand-held application device; and

providing the ordered pay-per-view program on the user television equipment in response to the at least one access communication.

22. The method defined in claim 10 wherein:
the interactive television application is an interactive television program guide;

the interactive television application data includes television program listings and additional programming information;

coordinating the touch-sensitive controls with features of the primary application comprises coordinating the touch-sensitive controls with features of the interactive television program guide; and

providing the user with an opportunity to access the interactive television application data with the hand-held access device using the touch-sensitive controls comprises providing the user with an opportunity to access additional programming information for a television program using the touch-sensitive controls.

23. The method defined in claim 10 wherein providing interactive television application data comprises providing interactive television application

- 64 -

data from a main facility for reception by the hand-held application device.

24. The method defined in claim 10 wherein providing interactive television application data comprises providing interactive television application data from interactive television application equipment for reception by the hand-held application device.

25. A system for providing a user with access to an interactive television application with a hand-held application device, comprising:

means for providing interactive television application data;

means for receiving the interactive television application data with a hand-held application device having one or more touch-sensitive controls;

means for providing the user with an opportunity to access the interactive television application data with the hand-held access device using the touch-sensitive controls.

26. The system defined in claim 25 wherein the means for providing interactive television application data comprises means for providing interactive television application data from a main facility for reception by the hand-held application device.

27. The system defined in claim 25 wherein the means for providing interactive television application data comprises means for providing

- 65 -

interactive television application data from interactive television application equipment for reception by the hand-held application device.

28. The system defined in claim 25 wherein:
the interactive television application is an interactive television program guide;
the interactive television application data includes television program listings; and
the means for providing the user with an opportunity to access the interactive television application data with the hand-held access device using the touch-sensitive controls comprises means for providing the user with an opportunity to browse program listings using the touch-sensitive controls.

29. The system defined in claim 28 further comprising means for providing a television program associated with a browsed program listing on the hand-held application device.

30. The system defined in claim 25 wherein:
the interactive television application is an interactive television program guide;
the interactive television application data includes television program listings; and
the means for providing the user with an opportunity to access the interactive television application data with the hand-held access device using the touch-sensitive controls comprises means for providing the user with an opportunity to set a reminder using the touch-sensitive controls.

- 66 -

31. The system defined in claim 30 further comprising means for providing the reminder on the hand-held access device as set by the user.

32. The system defined in claim 25 wherein:
the interactive television application is an interactive television program guide;
the interactive television application data includes television program listings; and
the means for providing the user with an opportunity to access the interactive television application data with the hand-held access device using the touch-sensitive controls comprises means for providing the user with an opportunity to order a pay-per-view program using the touch-sensitive controls.

33. The system defined in claim 25 wherein:
the interactive television application is an interactive television program guide;
the interactive television application data includes television program listings and additional programming information; and
the means for providing the user with an opportunity to access the interactive television application data with the hand-held access device using the touch-sensitive controls comprises means for providing the user with an opportunity to access additional programming information for a television program using the touch-sensitive controls.

34. The system defined in claim 25 further comprising:

- 67 -

means for receiving the interactive television application data with user television equipment for use by a primary application; and
means for coordinating the touch-sensitive controls with features of the primary application.

35. The system defined in claim 34 wherein the means for coordinating the touch-sensitive controls with features of the primary application comprises means for exchanging one or more access communications between the hand-held application device and the user television equipment.

36. The system defined in claim 34 wherein the interactive television application is an interactive television program guide, a home shopping application, a home wagering application, a home stock trading application, or a television-related e-mail application.

37. The system defined in claim 34 further comprising:

means for providing interactive application data for a non-television application;
means for receiving the interactive application data with the hand-held application device;
and

means for providing the user with an opportunity to access the interactive application data with the hand-held access device using the touch-sensitive controls.

- 68 -

38. The system defined in claim 37 wherein the interactive application is a calender, contact list, web browser, calculator, or to-do list.

39. The system defined in claim 34 wherein:
the interactive television application is an interactive television program guide;
the interactive television application data includes television program listings;
the means for coordinating the touch-sensitive controls with features of the primary application comprises means for coordinating the touch-sensitive controls with features of the interactive television program guide; and
the means for providing the user with an opportunity to access the interactive television application data with the hand-held access device using the touch-sensitive controls comprises means for providing the user with an opportunity to browse program listings using the touch-sensitive controls.

40. The system defined in claim 39 further comprising means for providing a television program associated with a browsed program listing on the hand-held application device.

41. The system defined in claim 39 further comprising:
means for providing at least one access communication to the user television equipment wherein the at least one access communication indicates to the user television equipment a browsed program listing;
and

- 69 -

means for providing a television program associated with a browsed program listing on the user television equipment in response to the at least one access communication.

42. The system defined in claim 34 wherein:
the interactive television application is an interactive television program guide;
the interactive television application data includes television program listings;
the means for coordinating the touch-sensitive controls with features of the primary application comprises means for coordinating the touch-sensitive controls with features of the interactive television program guide; and
the means for providing the user with an opportunity to access the interactive television application data with the hand-held access device using the touch-sensitive controls comprises means for providing the user with an opportunity to set a reminder using the touch-sensitive controls.

43. The system defined in claim 42 further comprising means for providing the reminder on the hand-held access device as set by the user.

44. The system defined in claim 34 wherein:
the interactive television application is an interactive television program guide;
the interactive television application data includes television program listings;
the means for coordinating the touch-sensitive controls with features of the primary

- 70 -

application comprises means for coordinating the touch-sensitive controls with features of the interactive television program guide; and

the means for providing the user with an opportunity to access the interactive television application data with the hand-held access device using the touch-sensitive controls comprises means for providing the user with an opportunity to order a pay-per-view program using the touch-sensitive controls.

45. The system defined in claim 44 further comprising:

means for providing at least one access communication to the user television equipment wherein the at least one access communication indicates to the user television equipment a pay-per-view program ordered by the user using the hand-held application device; and

means for providing the ordered pay-per-view program on the user television equipment in response to the at least one access communication.

46. The system defined in claim 34 wherein:

the interactive television application is an interactive television program guide;

the interactive television application data includes television program listings and additional programming information;

the means for coordinating the touch-sensitive controls with features of the primary application comprises means for coordinating the touch-sensitive controls with features of the interactive television program guide; and

- 71 -

the means for providing the user with an opportunity to access the interactive television application data with the hand-held access device using the touch-sensitive controls comprises means for providing the user with an opportunity to access additional programming information for a television program using the touch-sensitive controls.

47. The system defined in claim 34 wherein the means for providing interactive television application data comprises means for providing interactive television application data from a main facility for reception by the hand-held application device.

48. The system defined in claim 34 wherein the means for providing interactive television application data comprises means for providing interactive television application data from interactive television application equipment for reception by the hand-held application device.

49. A system for providing a user with access to an interactive television application with a hand-held application device, comprising:

a first communications device configured to provide interactive television application data; and

a hand-held application device comprising:

a second communications device configured to receive the interactive television application data;

- 72 -

a user interface having one or more touch-sensitive controls that provide the user with an opportunity to access the interactive television application data; and

processing circuitry configured to (i) direct the second communications device to receive the interactive television application data, and (ii) direct the user interface to display the one or more touch-sensitive controls.

50. The system defined in claim 49 wherein the first communications device is located at a main facility.

51. The system defined in claim 49 wherein the first communications device is located at interactive television application equipment.

52. The system defined in claim 49 wherein:
the interactive television application is an interactive television program guide;
the interactive television application data includes television program listings; and
the touch-sensitive controls are further configured to provide the user with an opportunity to browse program listings.

53. The system defined in claim 52 wherein:
the second communications device is further configured to receive a television program associated with a browsed program listing; and

- 73 -

the user interface is further configured to display the television program on the hand-held application device.

54. The system defined in claim 49 wherein:
the interactive television application is an interactive television program guide;
the interactive television application data includes television program listings; and
the touch-sensitive controls are further configured to provide the user with an opportunity to provide the user with an opportunity to set a reminder.

55. The system defined in claim 54 wherein the hand-held access device is further configured to direct the user interface to provide the reminder as set by the user.

56. The system defined in claim 49 wherein:
the interactive television application is an interactive television program guide;
the interactive television application data includes television program listings; and
the touch-sensitive controls are further configured to provide the user with an opportunity to provide the user with an opportunity to order a pay-per-view program.

57. The system defined in claim 49 wherein:
the interactive television application is an interactive television program guide;

- 74 -

the interactive television application data includes television program listings and additional programming information; and

the touch-sensitive controls are further configured to provide the user with an opportunity to provide the user with an opportunity to access additional programming information for a television program.

58. The system defined in claim 49 wherein:
the system further comprises a primary application running at least partially on user television equipment;

the first communications device is located within the user television equipment and is further configured to receive interactive television application data for use by the primary application; and

the processing circuitry is further configured to coordinate the touch-sensitive controls with features of the primary application.

59. The system defined in claim 58 wherein the processing circuitry is further configured to direct the second communications device to exchange one or more access communications with the user television equipment.

60. The system defined in claim 58 wherein the interactive television application is an interactive television program guide, a home shopping application, a home wagering application, a home stock

- 75 -

trading application, or a television-related e-mail application.

61. The system defined in claim 58 further comprising:

the first communications device is further configured to provide interactive application data for a non-television application;

the second communications device is further configured to receive the interactive application data; and

the touch-sensitive controls are further configured to provide the user with an opportunity to access the interactive application data.

62. The system defined in claim 61 wherein the interactive application is a calender, contact list, web browser, calculator, or to-do list.

63. The system defined in claim 58 wherein:

the interactive television application is an interactive television program guide;

the interactive television application data includes television program listings;

the processing circuitry is further configured to coordinate the touch-sensitive controls with features of the interactive television program guide; and

the touch-sensitive controls are further configured to provide the user with an opportunity to browse program listings.

64. The system defined in claim 63 wherein:

- 76 -

the second communications device is further configured to receive a television program associated with a browsed program listing; and

the user interface is further configured to display the television program on the hand-held application device.

65. The system defined in claim 64 wherein the first communications device is located in user television equipment;

the processing circuitry is further configured to direct the second communications device to provide at least one access communication to the second communication device, wherein the at least one access communication indicates to the user television equipment a browsed program listing; and

the user television equipment is further configured to provide a television program associated with a browsed program listing in response to the at least one access communication.

66. The system defined in claim 58 wherein: the interactive television application is an interactive television program guide;

the interactive television application data includes television program listings;

the processing circuitry is further configured to coordinate the touch-sensitive controls with features of the interactive television program guide; and

the touch-sensitive controls are further configured to provide the user with an opportunity to set a reminder.

- 77 -

67. The system defined in claim 66 wherein the hand-held application device is further configured to direct the user interface to provide the reminder on the hand-held access device as set by the user.

68. The system defined in claim 58 wherein:
the interactive television application is an interactive television program guide;

the interactive television application data includes television program listings;

the processing circuitry is further configured to coordinate the touch-sensitive controls with features of the interactive television program guide; and

the touch-sensitive controls are further configured to provide the user with an opportunity to order a pay-per-view program.

69. The system defined in claim 68 wherein:
the first communications device is located in user television equipment;

the processing circuitry is further configured to direct the second communications device to provide at least one access communication to the user television equipment, wherein the at least one access communication indicates to the user television equipment a pay-per-view program ordered by the user using the hand-held application device; and

the user television equipment is configured to provide the ordered pay-per-view program in response to the at least one access communication.

- 78 -

70. The system defined in claim 58 wherein:
the interactive television application
is an interactive television program guide;
the interactive television application
data includes television program listings and
additional programming information;
the processing circuitry is further
configured to coordinate the touch-sensitive controls
with features of the interactive television program
guide; and
the touch-sensitive controls are further
configured to provide the user with an opportunity to
access additional programming information for a
television program.

71. The system defined in claim 58 wherein
first communications device is located at a main
facility.

72. The system defined in claim 58 wherein
the first communications device is located at
interactive television application equipment.

73. The system defined in claim 49 wherein:
the first communications device is
further configured to provide the interactive
television application data over a 900 MHz link; and
the second communications device is
further configured to receive the interactive
television application data over the 900 MHz link.

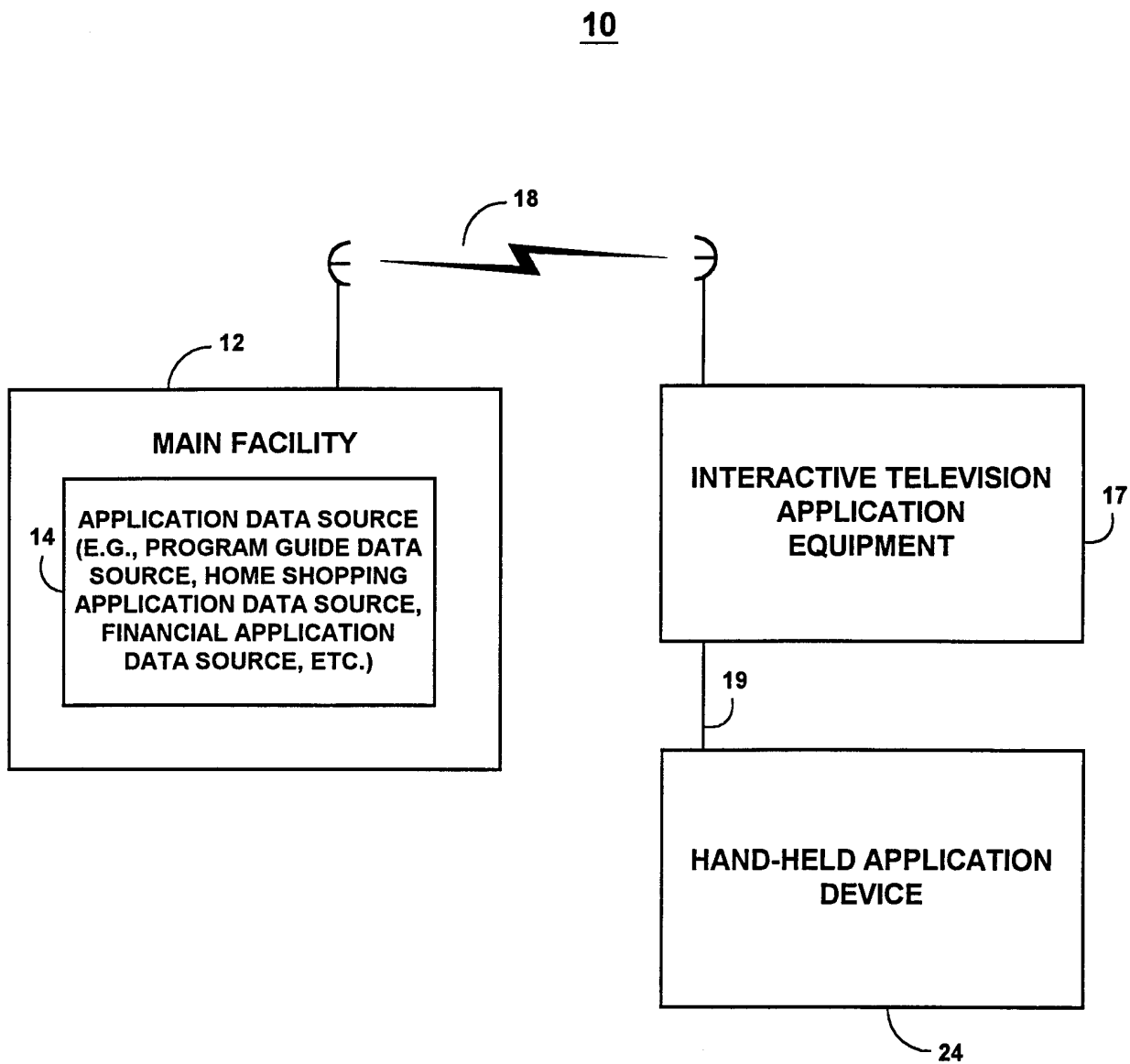

FIG. 1

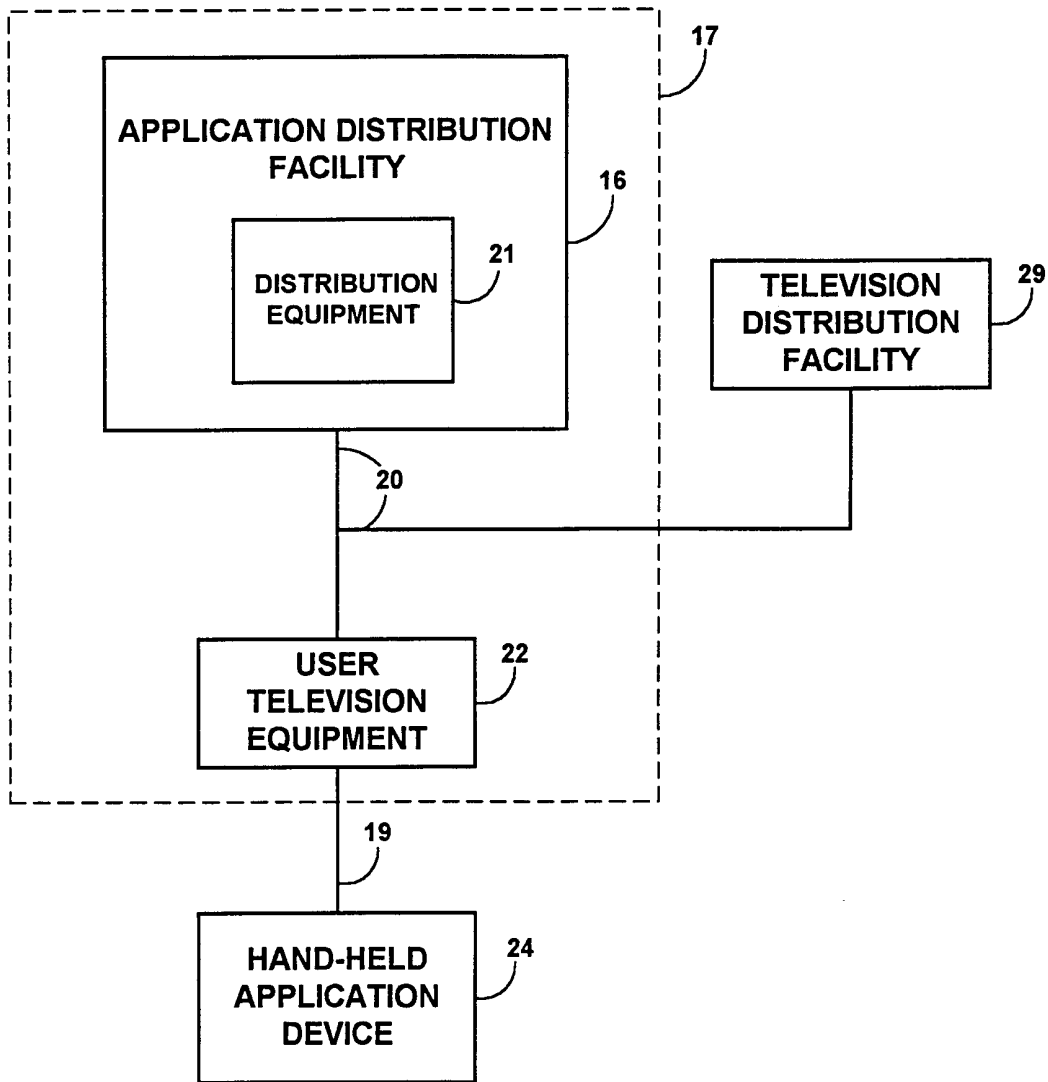

FIG. 2a

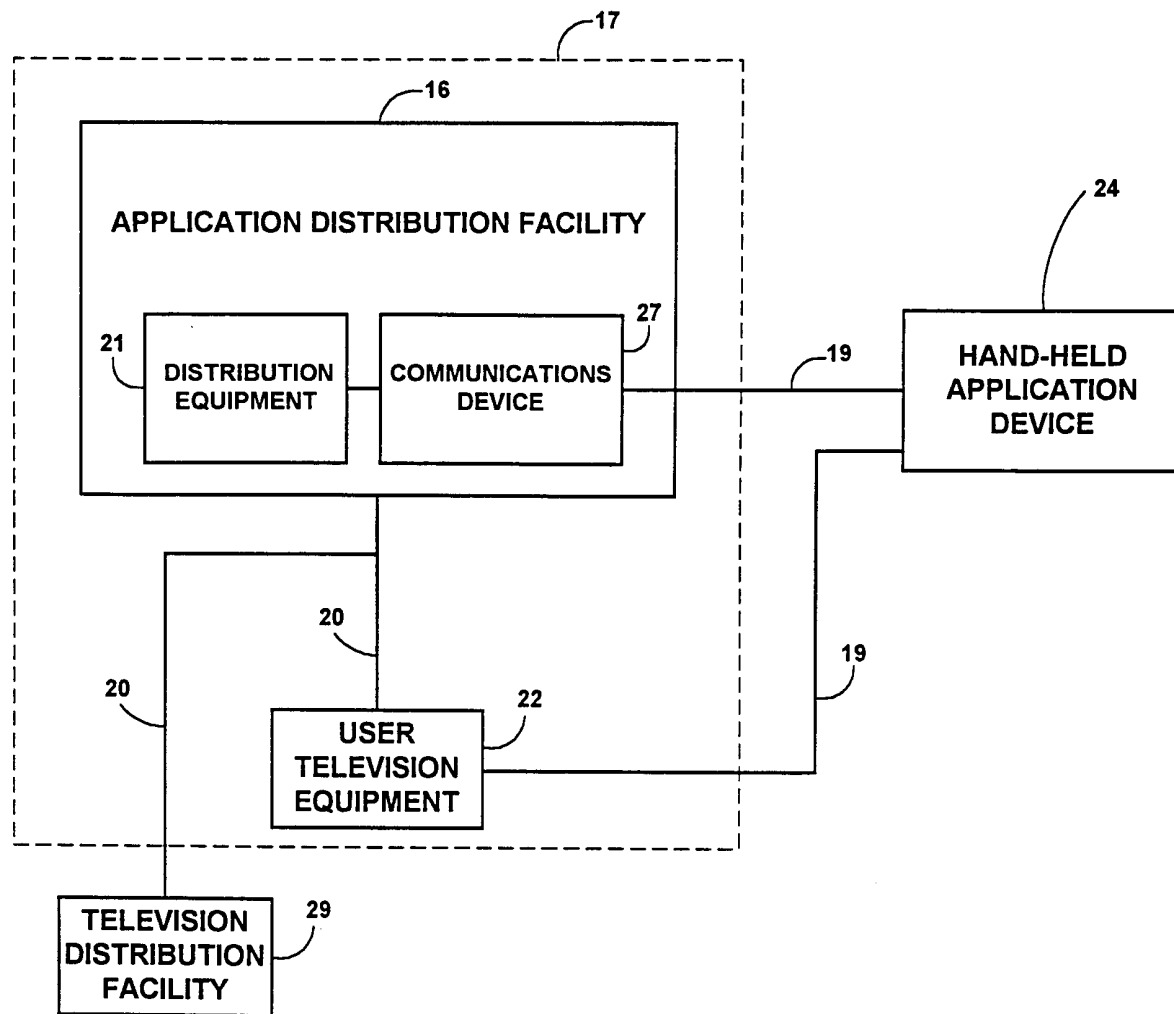

FIG. 2b

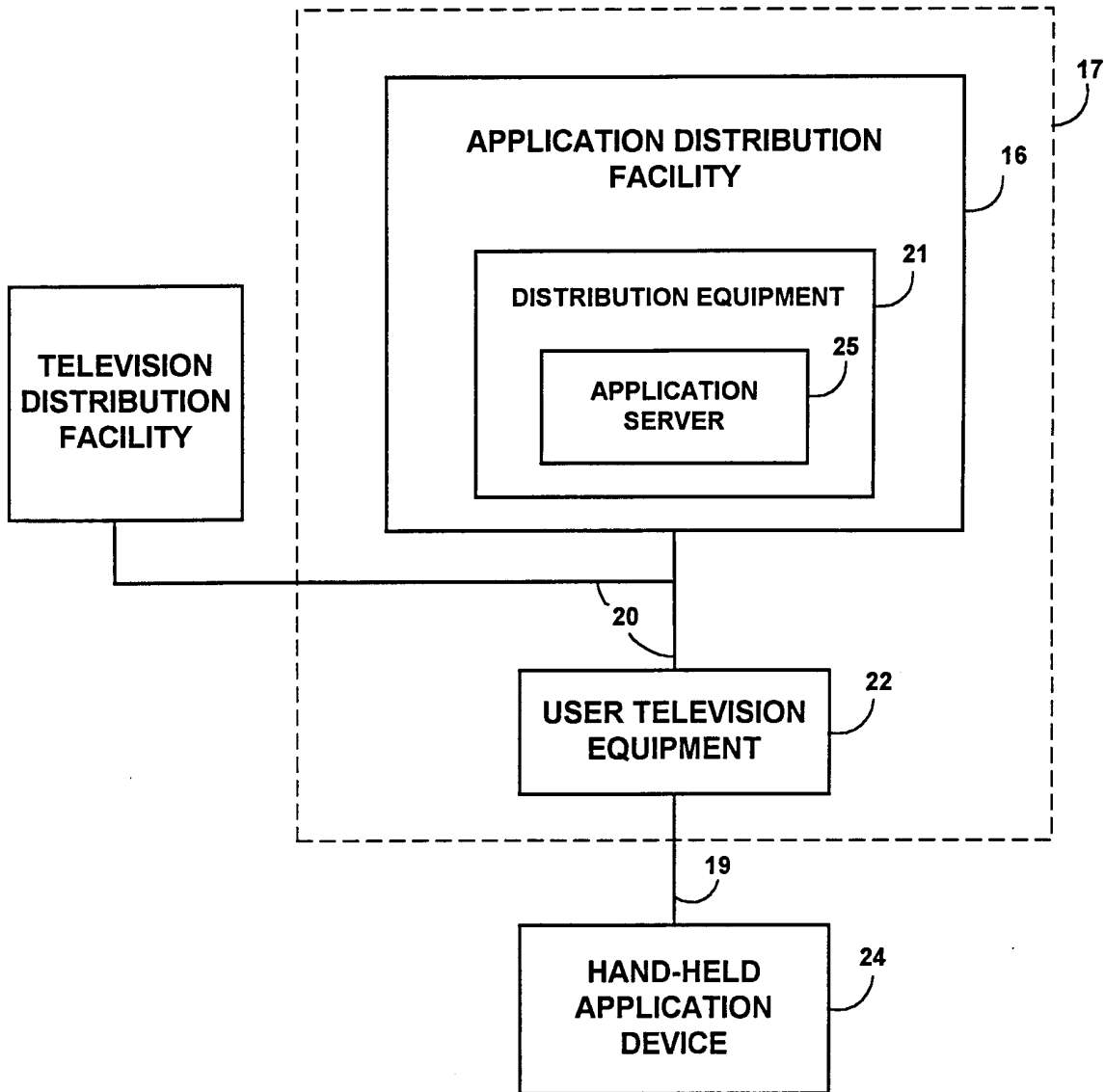

FIG. 2c

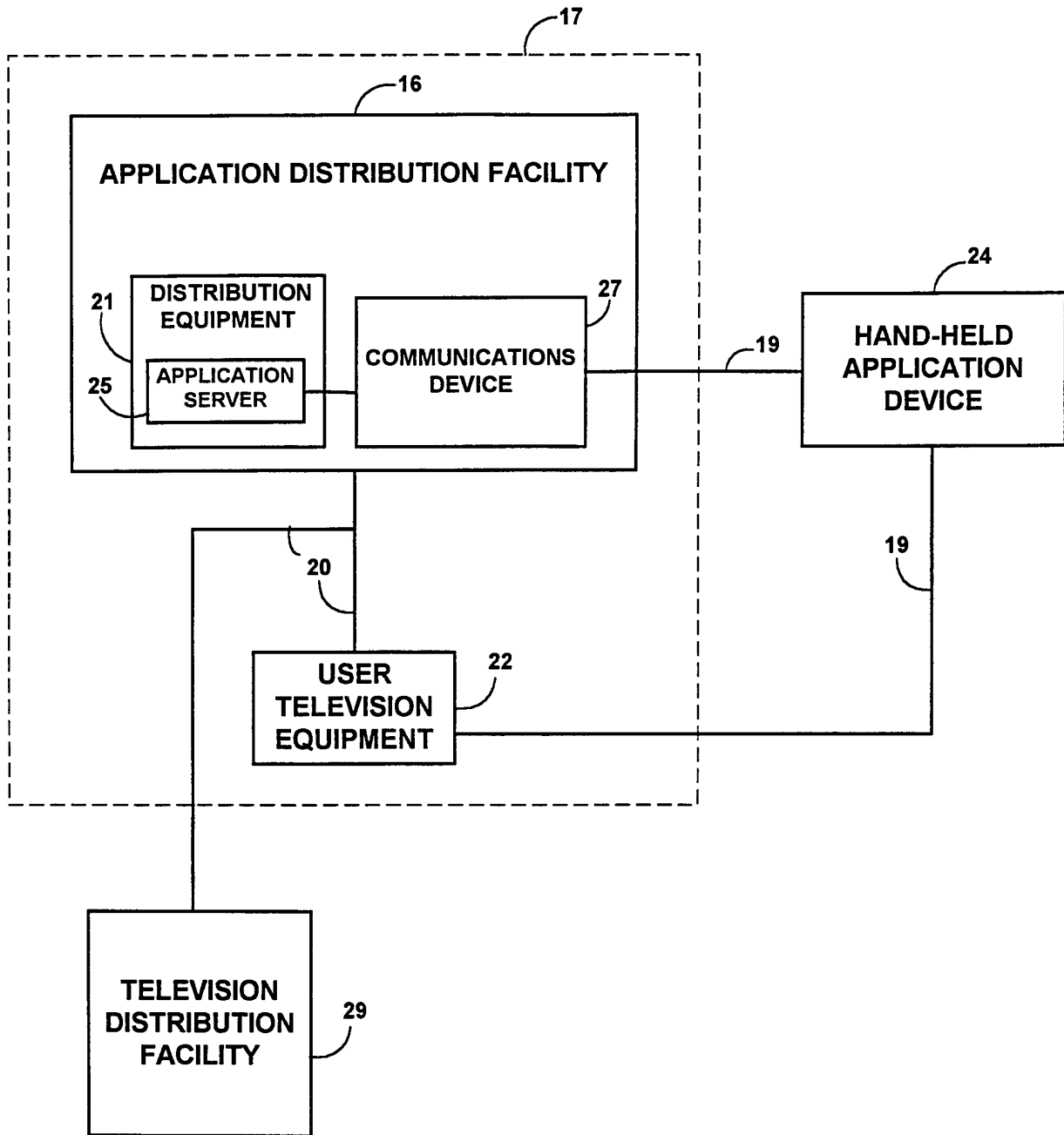

FIG. 2d

6/27

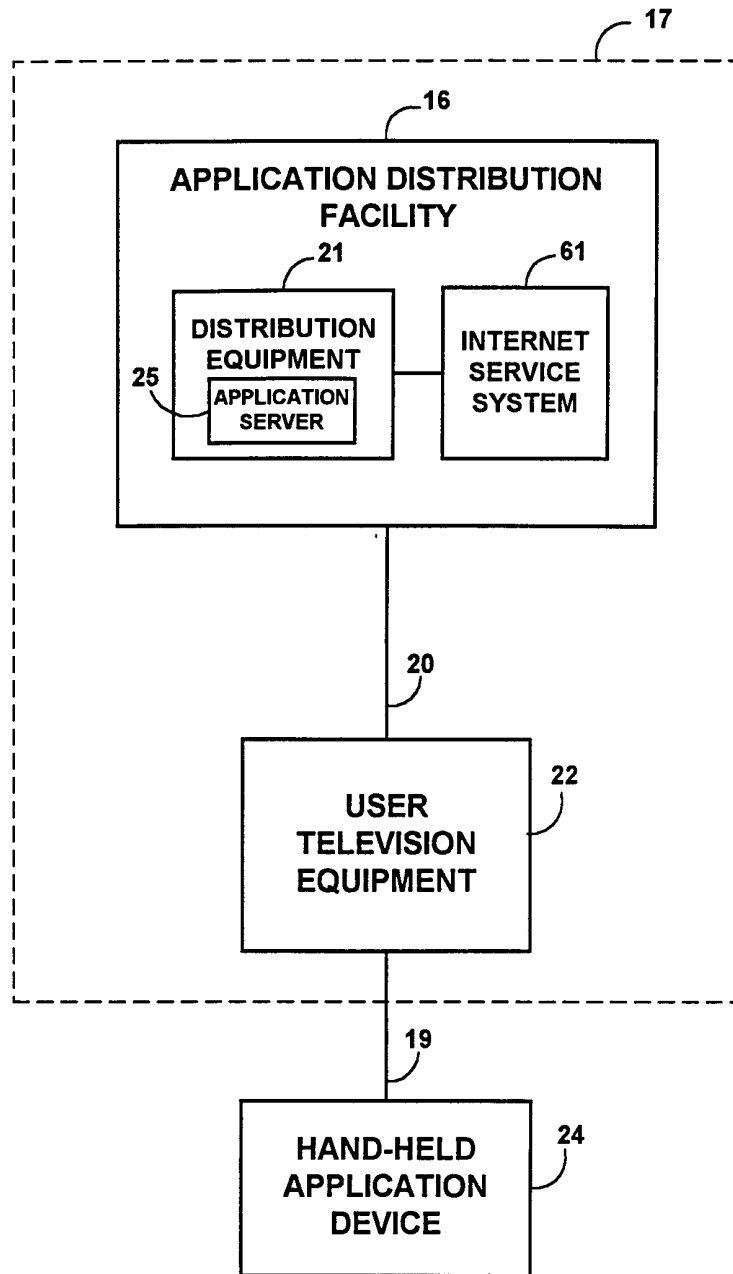

FIG. 2e

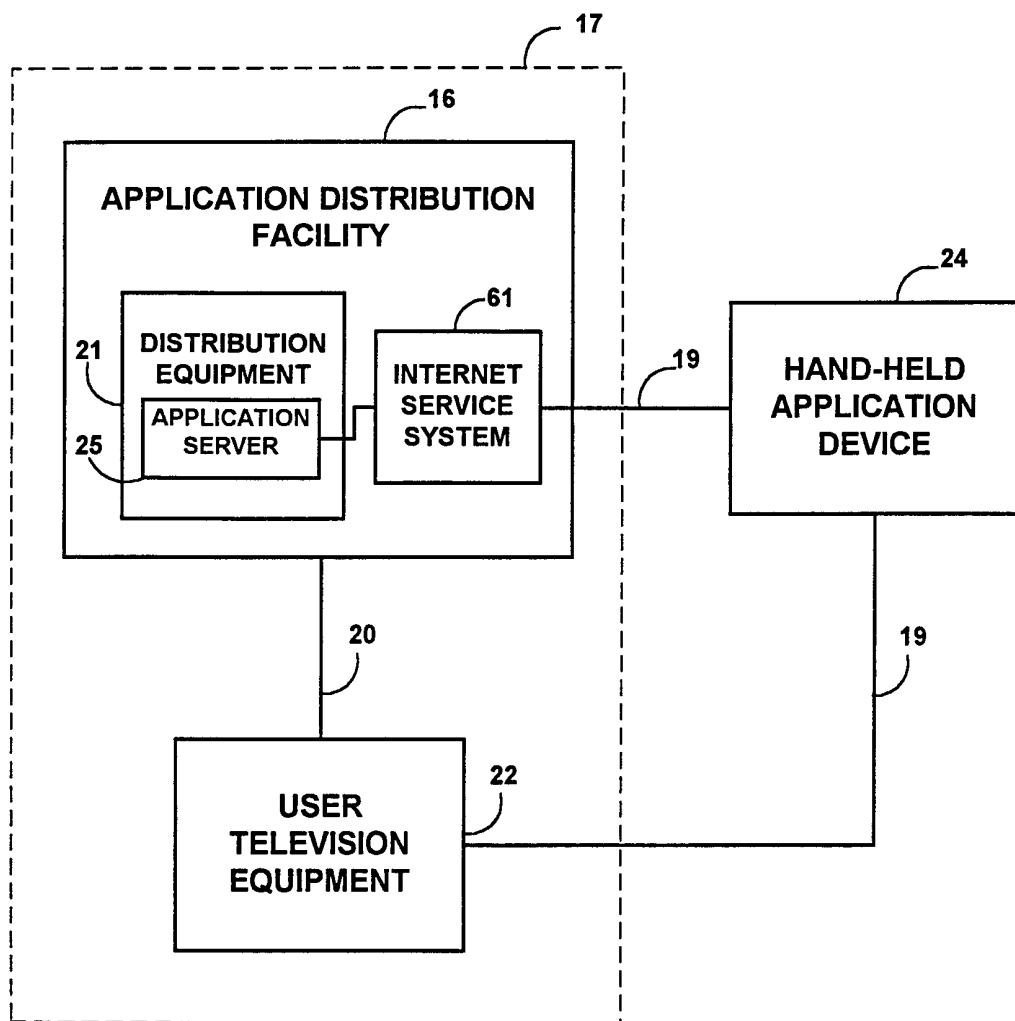

FIG. 2f

8/27

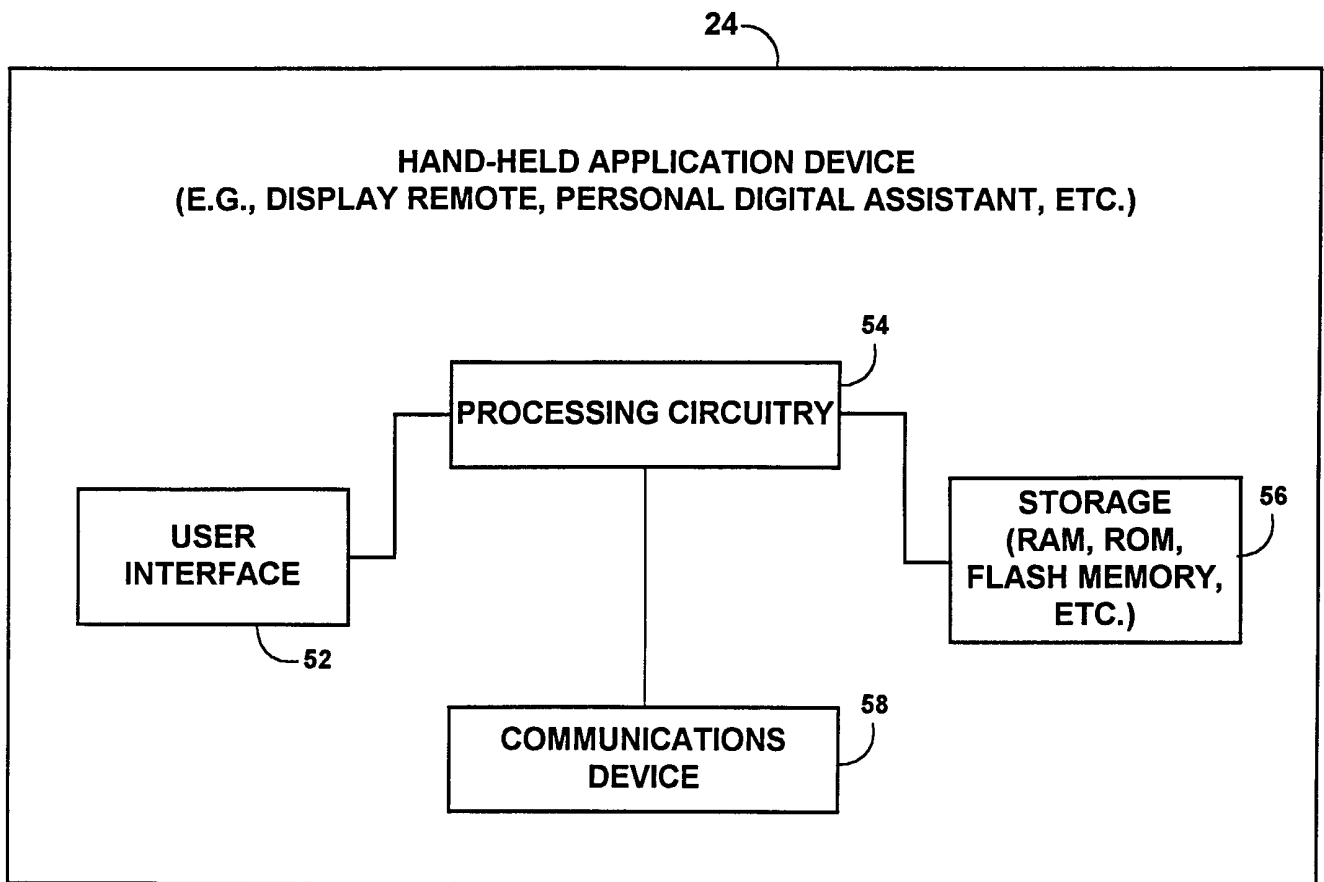

FIG. 3

9/27

22

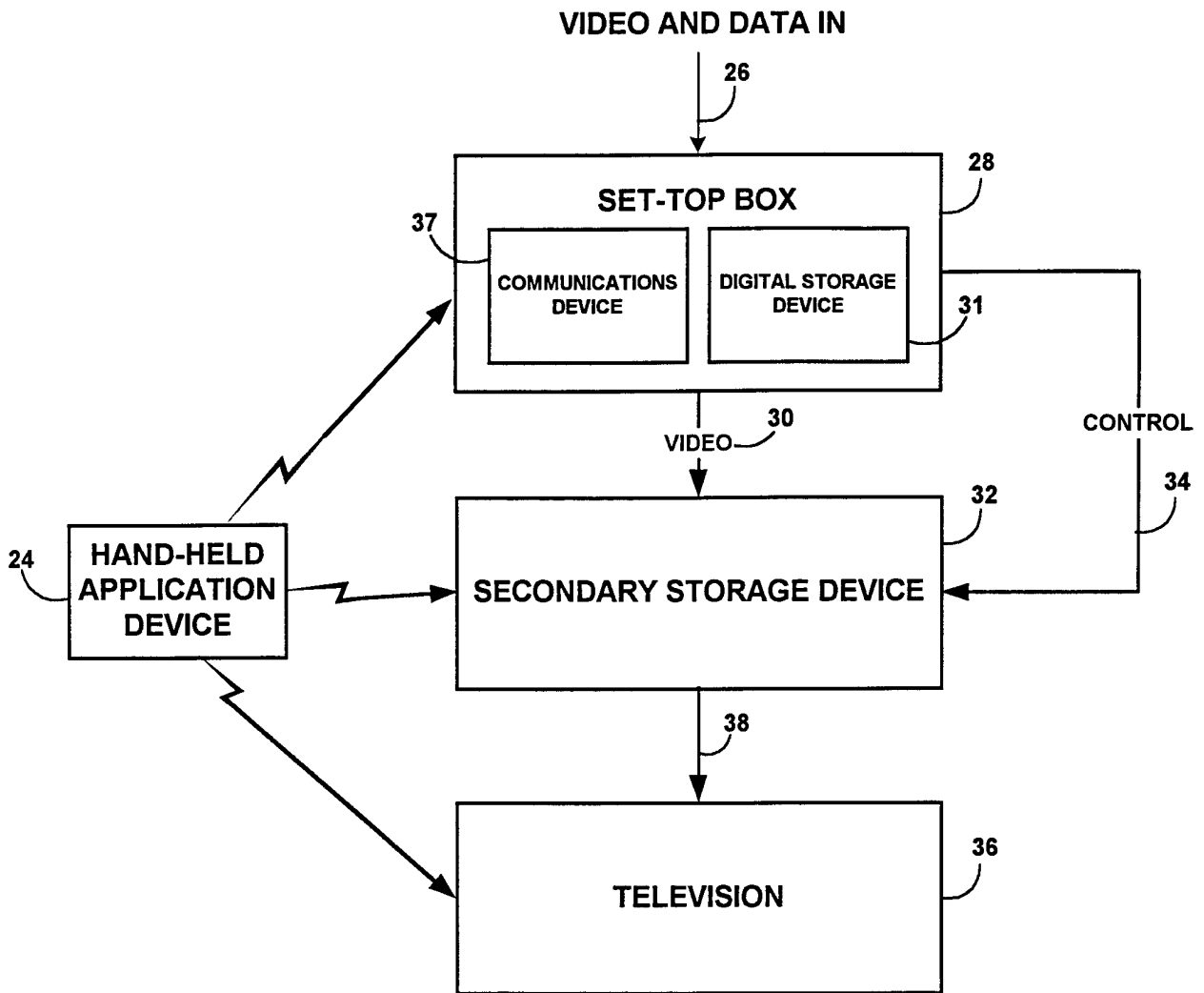

FIG. 4

10/27

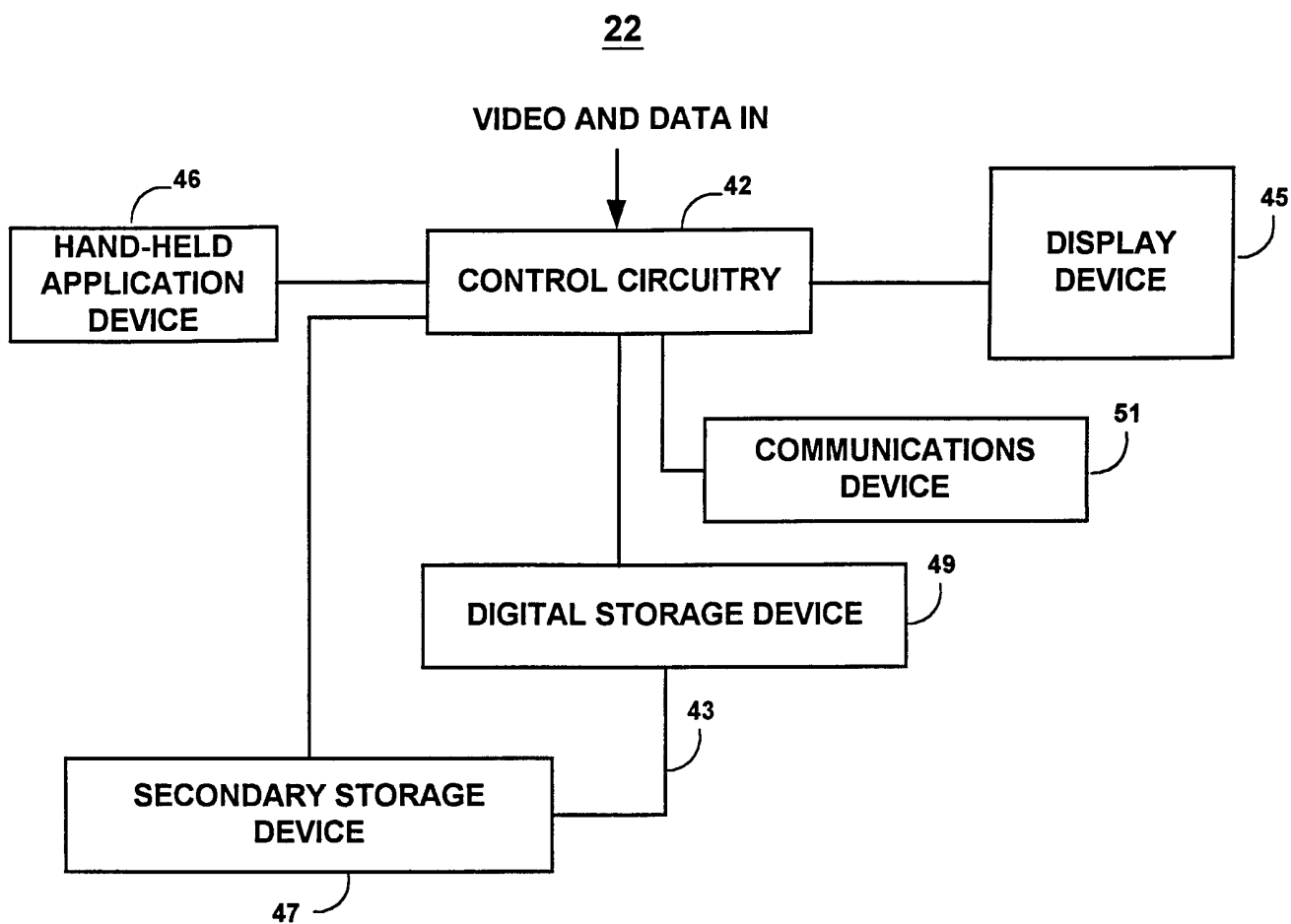

FIG. 5

11/27

601

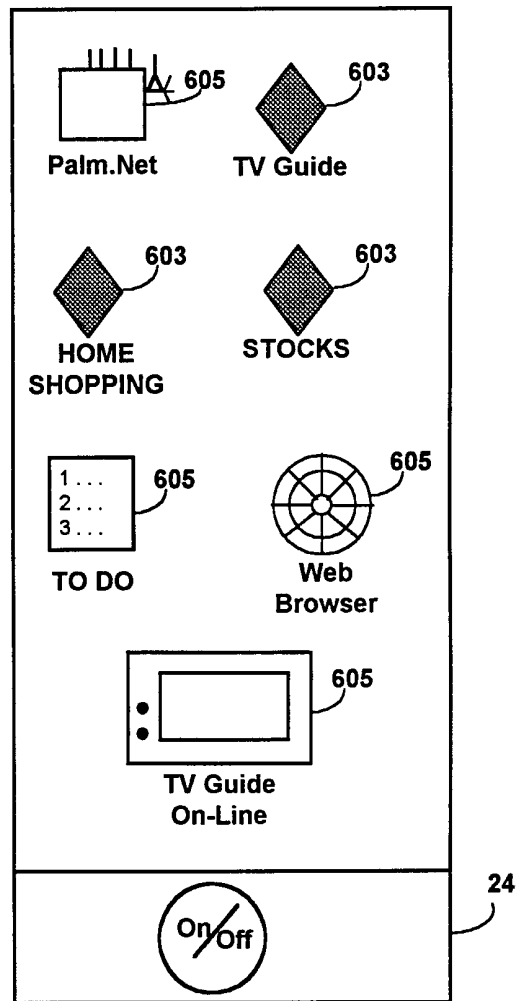

FIG. 6

12/27

701

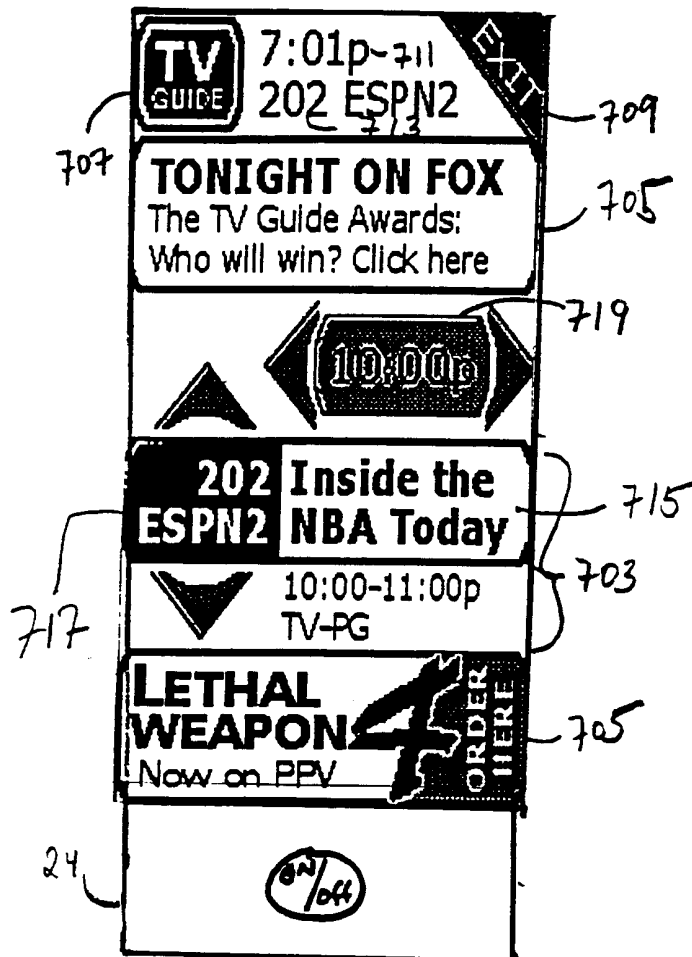

FIG. 7

13/27

801

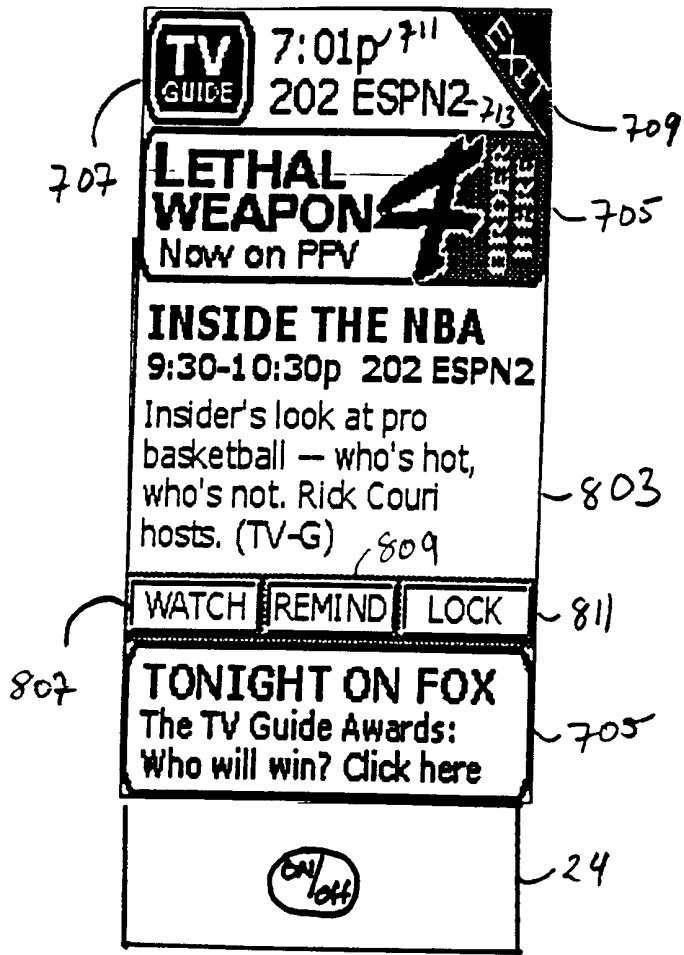

FIG. 8

14/27

901



FIG. 9

15/27

1000

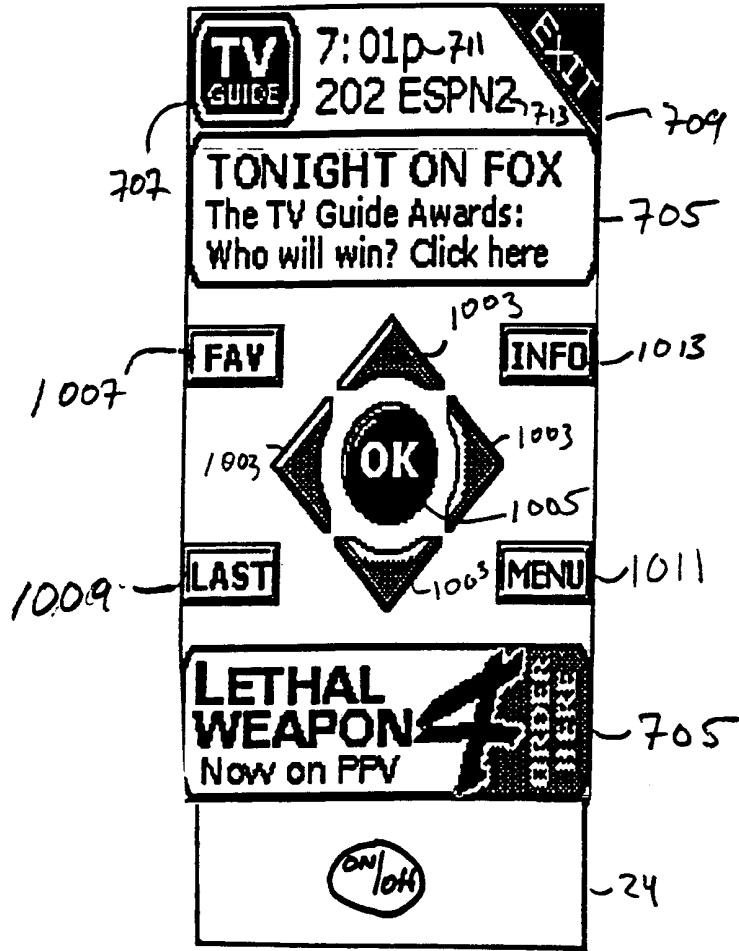

FIG. 10

100

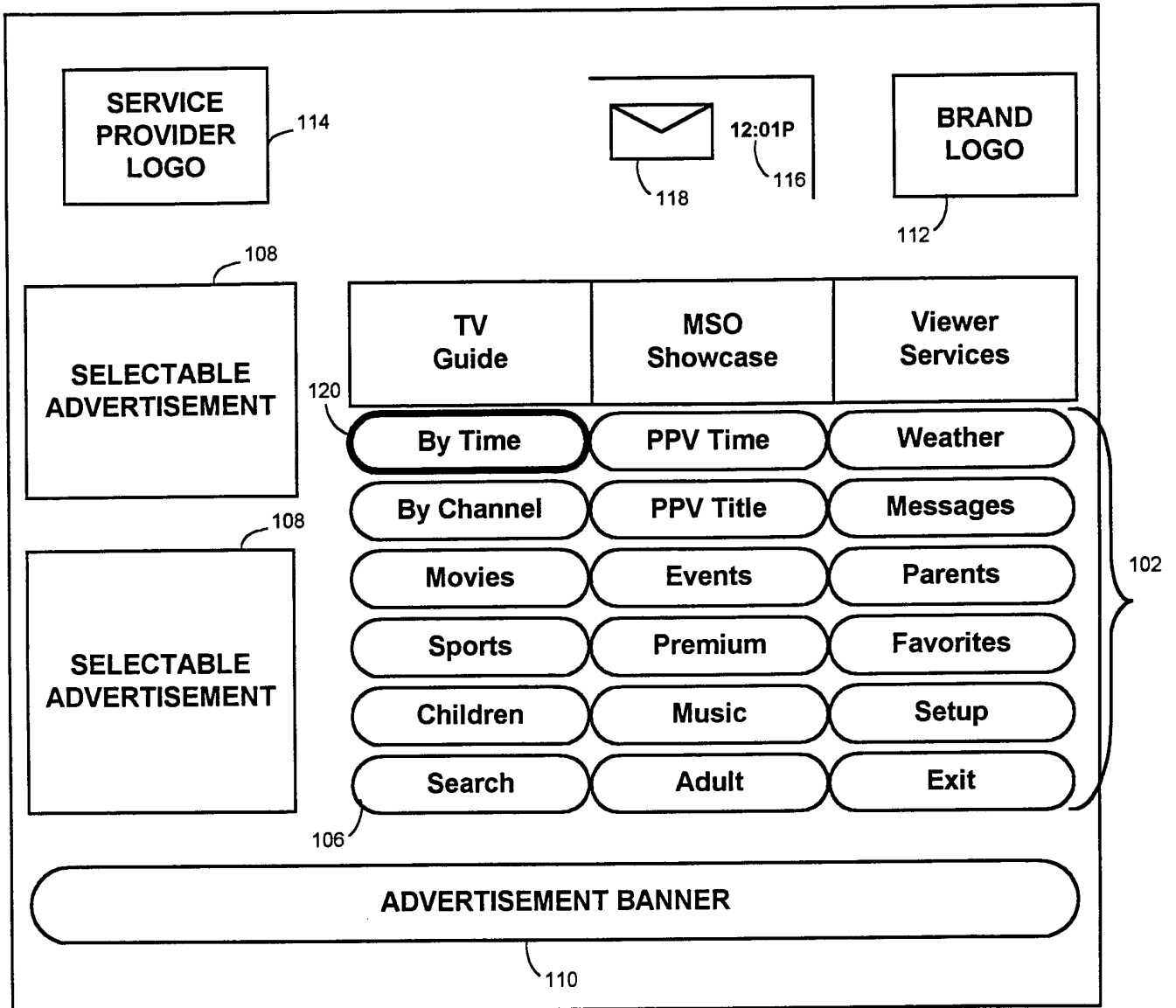

FIG. 11

17/27

130

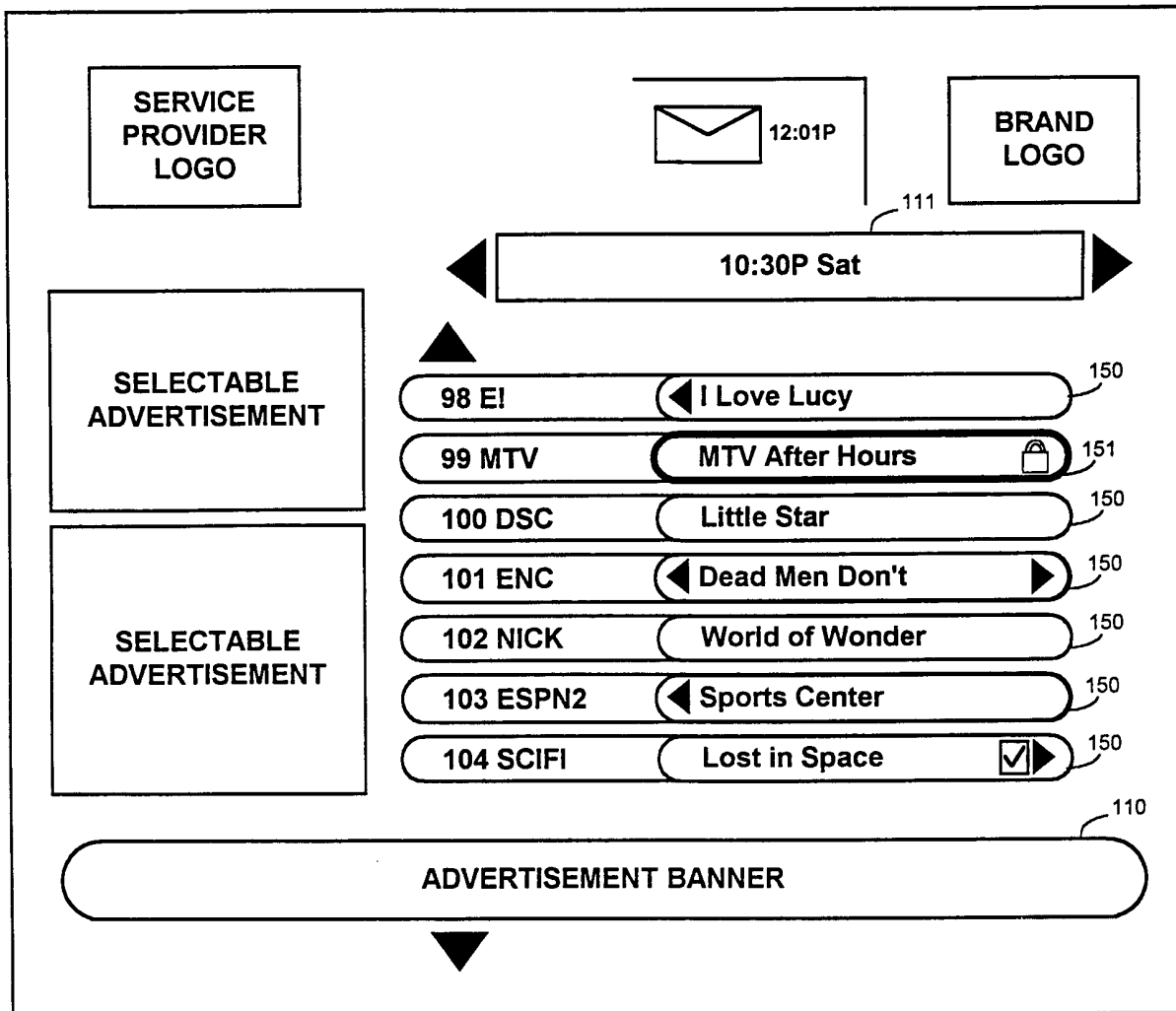

FIG. 12

18/27

231

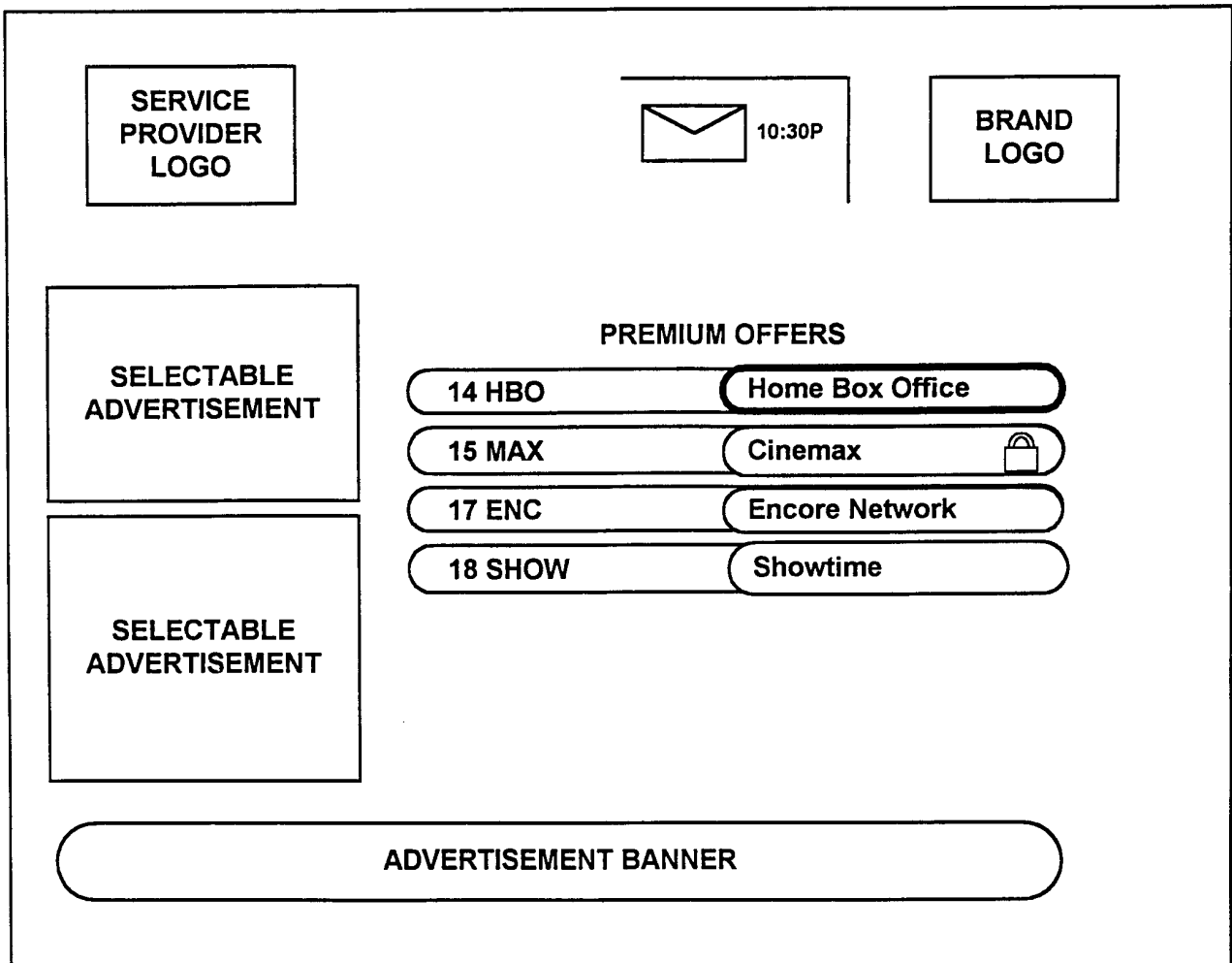

FIG. 13

1401

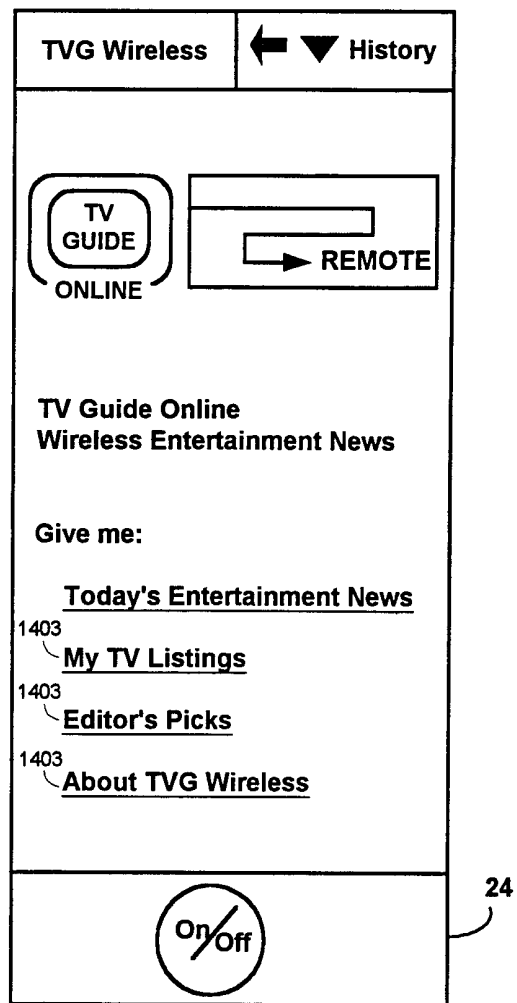

FIG. 14

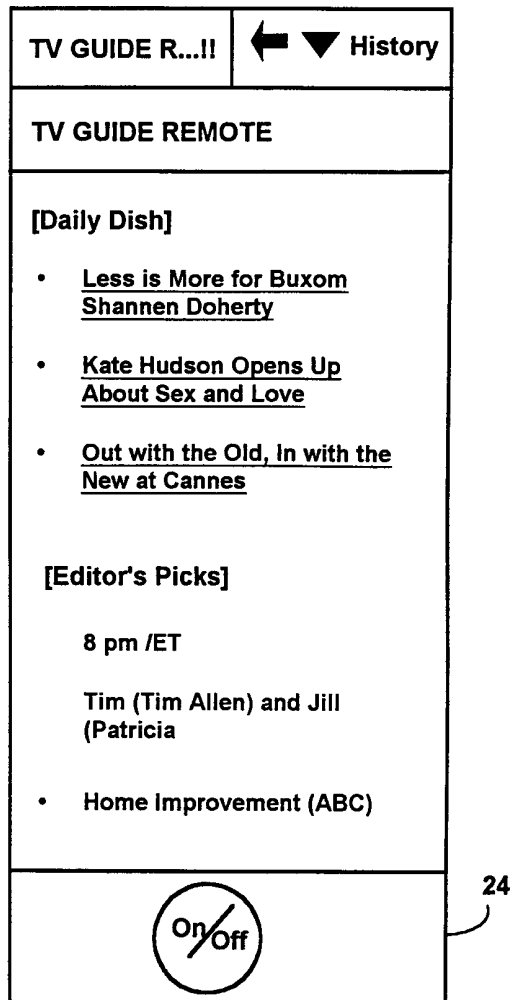

FIG. 15



FIG. 16a

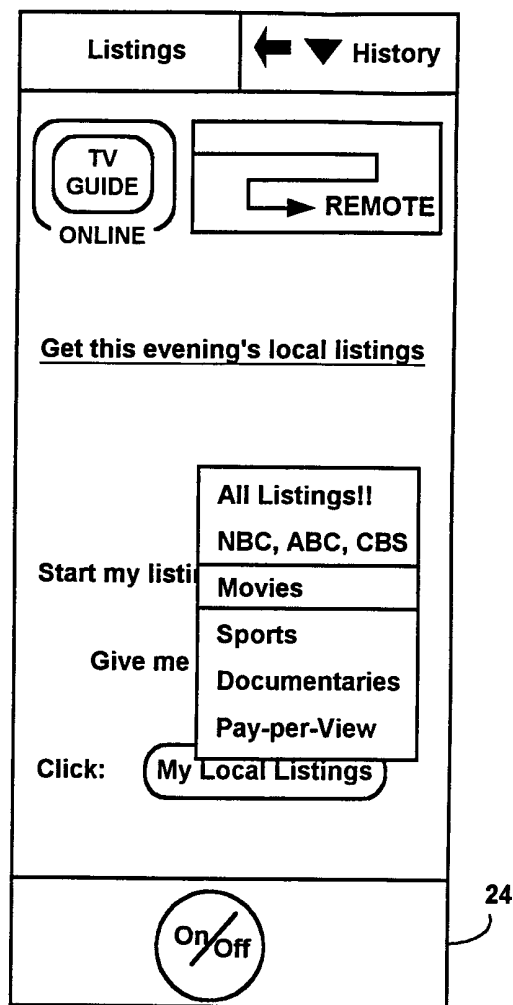

FIG. 16b

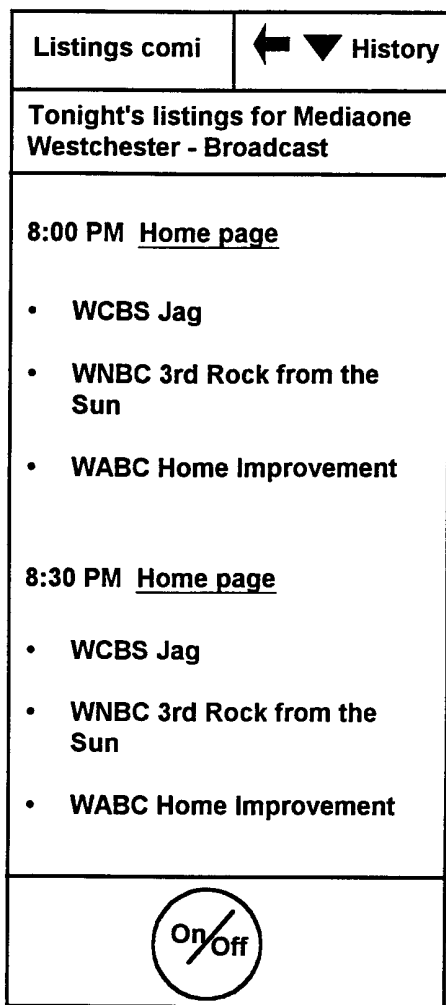

FIG. 16c

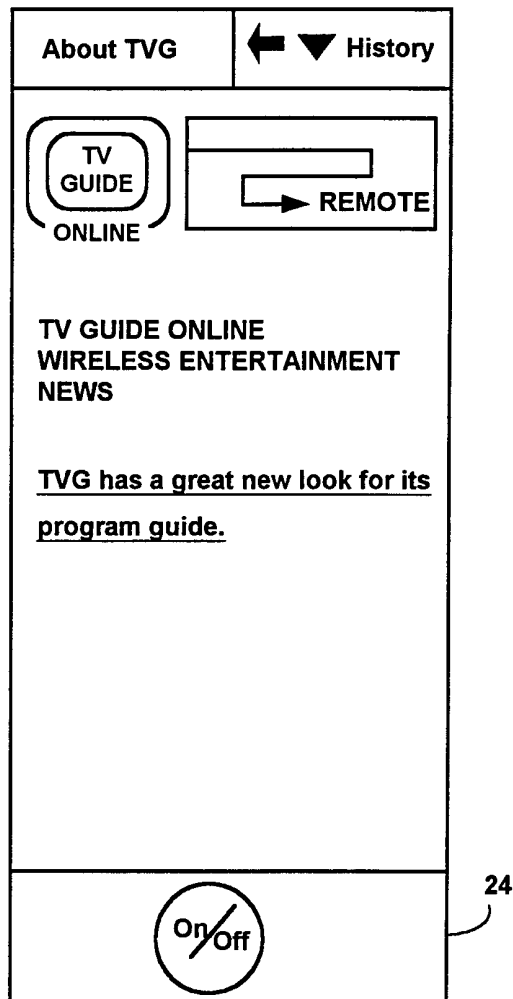

FIG. 17

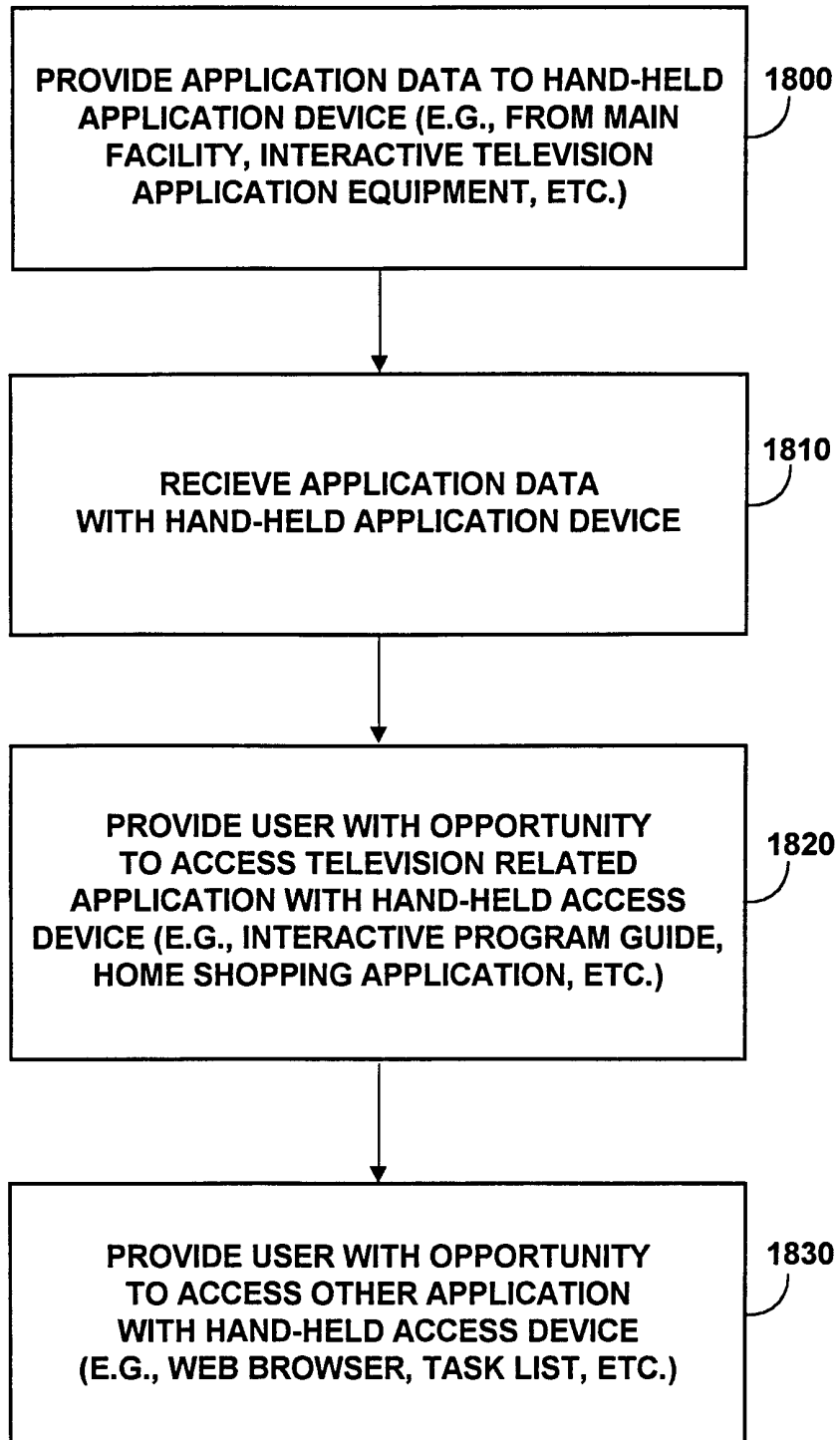

FIG. 18

26/27

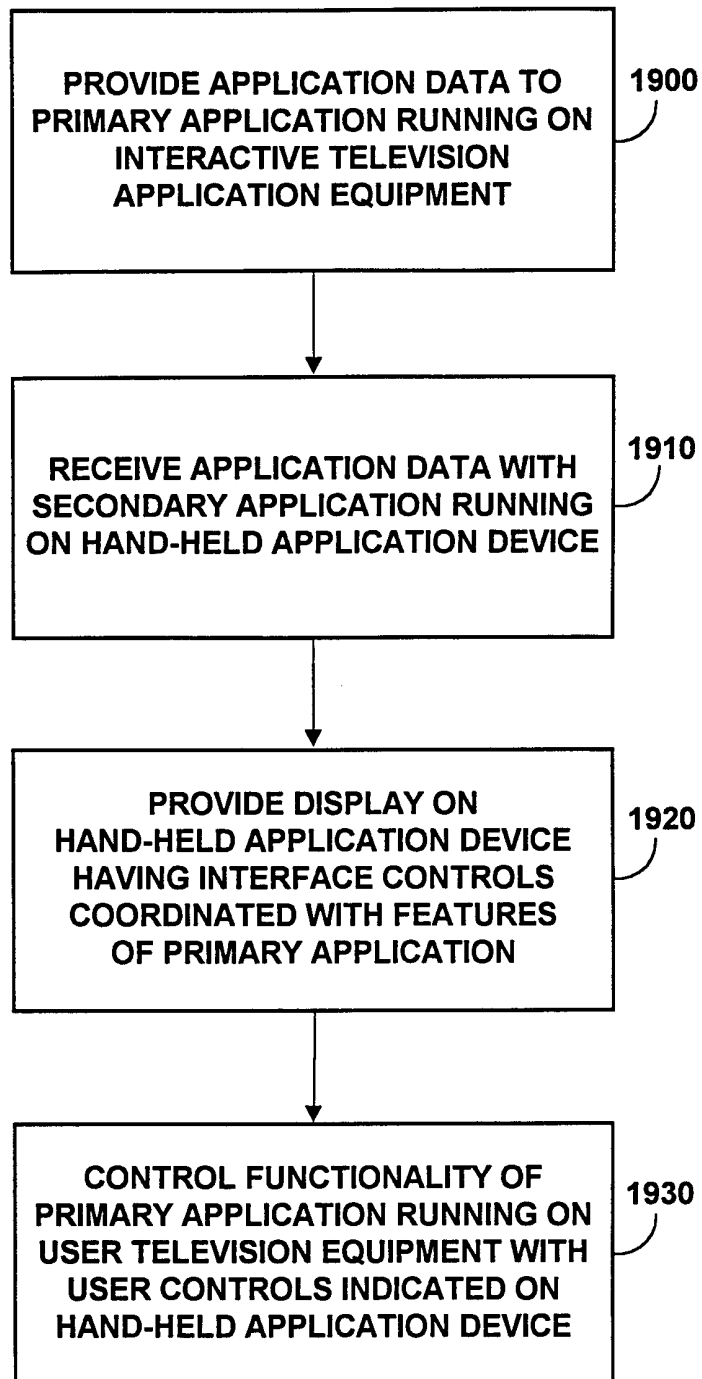

FIG. 19

27/27

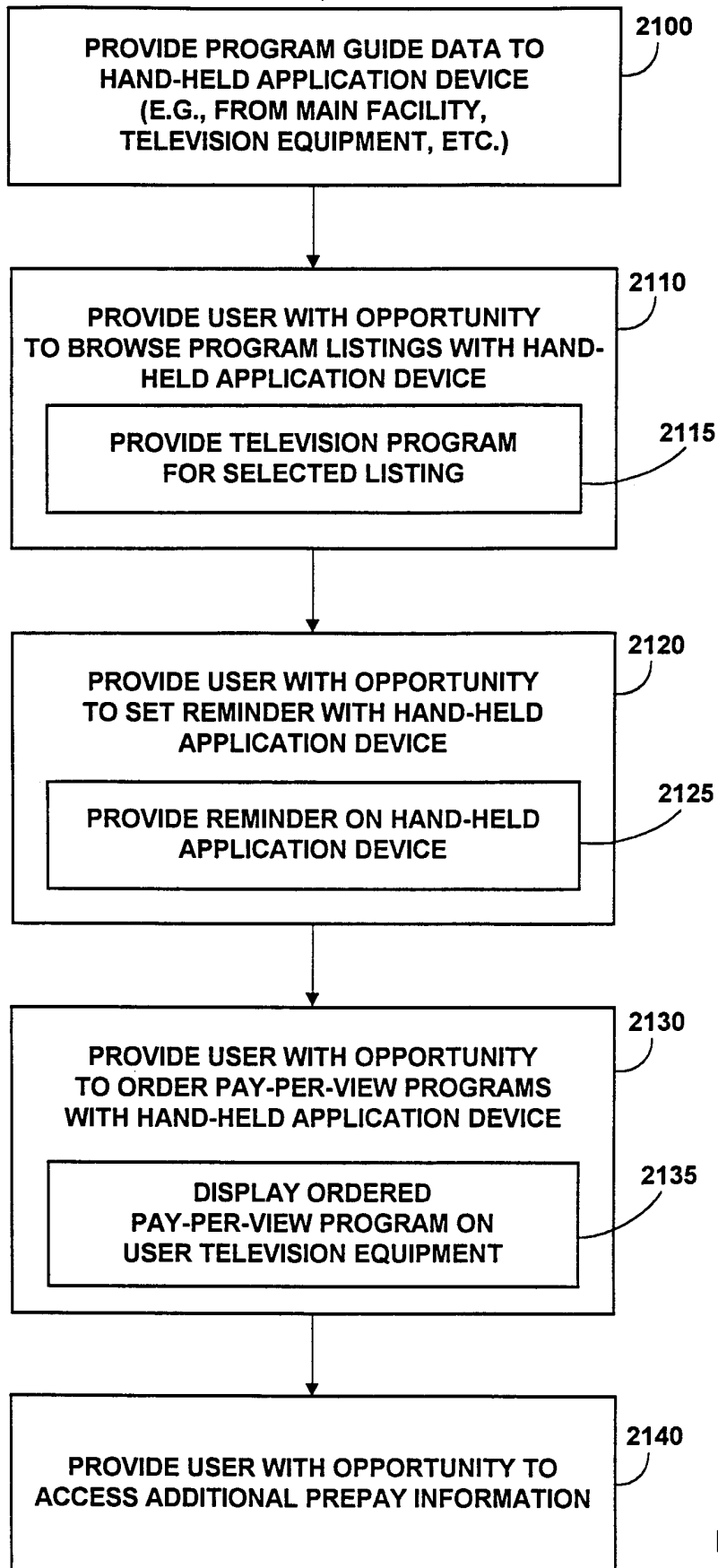

FIG. 20

INTERNATIONAL SEARCH REPORT

Int'l Application No
PCT/US 00/40148

A. CLASSIFICATION OF SUBJECT MATTER
IPC 7 H04N7/173 H04N5/445

According to International Patent Classification (IPC) or to both national classification and IPC

B. FIELDS SEARCHED

Minimum documentation searched (classification system followed by classification symbols)
IPC 7 H04N

Documentation searched other than minimum documentation to the extent that such documents are included in the fields searched

Electronic data base consulted during the international search (name of data base and, where practical, search terms used)

EPO-Internal, WPI Data, PAJ

C. DOCUMENTS CONSIDERED TO BE RELEVANT

Category *	Citation of document, with indication, where appropriate, of the relevant passages	Relevant to claim No.
X	US 5 410 326 A (GOLDSTEIN STEVEN W) 25 April 1995 (1995-04-25)	1-3, 10-14, 24-27, 34-38, 48-51, 58-62, 71,72
Y	column 3, line 45 - line 51 column 7, line 33 - line 41 column 11, line 15 - line 26	4,5,9, 15,16, 22,23, 28,29, 33,39, 40,46, 47,52, 53,57, 63,64,73
	-/--	

Further documents are listed in the continuation of box C.

Patent family members are listed in annex.

* Special categories of cited documents :

- *A* document defining the general state of the art which is not considered to be of particular relevance
- *E* earlier document but published on or after the international filing date
- *L* document which may throw doubts on priority claim(s) or which is cited to establish the publication date of another citation or other special reason (as specified)
- *O* document referring to an oral disclosure, use, exhibition or other means
- *P* document published prior to the international filing date but later than the priority date claimed

- *T* later document published after the international filing date or priority date and not in conflict with the application but cited to understand the principle or theory underlying the invention
- *X* document of particular relevance; the claimed invention cannot be considered novel or cannot be considered to involve an inventive step when the document is taken alone
- *Y* document of particular relevance; the claimed invention cannot be considered to involve an inventive step when the document is combined with one or more other such documents, such combination being obvious to a person skilled in the art.
- *&* document member of the same patent family

Date of the actual completion of the international search

10 October 2000

Date of mailing of the international search report

16/10/2000

Name and mailing address of the ISA

European Patent Office, P.B. 5818 Patentlaan 2
NL - 2280 HV Rijswijk
Tel. (+31-70) 340-2040, Tx. 31 651 epo nl,
Fax: (+31-70) 340-3016

Authorized officer

Sindic, G

INTERNATIONAL SEARCH REPORT

Int. Patent Application No
PCT/US 00/40148

C.(Continuation) DOCUMENTS CONSIDERED TO BE RELEVANT

Category *	Citation of document, with indication, where appropriate, of the relevant passages	Relevant to claim No.
X	<p>column 14, line 56 - line 65 -----</p> <p>US 5 668 591 A (SHINTANI PETER) 16 September 1997 (1997-09-16)</p>	<p>1,3, 10-12, 24,25, 27, 34-36, 48,49, 51, 58-60,72</p>
Y	<p>column 3, line 22 - line 49 column 3, line 64 -column 4, line 9 -----</p> <p>WO 98 16062 A (CHANG ALLEN) 16 April 1998 (1998-04-16)</p>	<p>4,5,9, 15,16, 22,23, 28,29, 33,39, 40,46, 47,52, 53,57, 63,64,73</p>
A	<p>page 2, line 19 - line 21 page 3, line 35 -page 4, line 25 page 6, column 15 -column 21 page 6, line 33 - line 35 -----</p> <p>US 5 898 398 A (KUMAI HISAO) 27 April 1999 (1999-04-27) column 3, line 22 - line 32 column 8, line 18 - line 26</p>	<p>1,4,25, 28,49,52</p>
A	<p>WO 98 43158 A (EVOLVE PRODUCTS INC ;DARBEE PAUL (US); DONNELL FRANK O (US); THOMS) 1 October 1998 (1998-10-01) page 2, line 32 -page 3, line 1 page 3, line 32 -page 4, line 4 -----</p>	<p>1,25,49</p>

INTERNATIONAL SEARCH REPORT

Information on patent family members

Int'l Application No PCT/US 00/40148

Patent document cited in search report	Publication date	Patent family member(s)	Publication date
US 5410326 A	25-04-1995	NONE	
US 5668591 A	16-09-1997	JP 7271697 A GB 2288044 A,B	20-10-1995 04-10-1995
WO 9816062 A	16-04-1998	AU 4896397 A CN 1237308 A EP 0931415 A	05-05-1998 01-12-1999 28-07-1999
US 5898398 A	27-04-1999	JP 9182173 A EP 0811274 A WO 9723960 A	11-07-1997 10-12-1997 03-07-1997
WO 9843158 A	01-10-1998	US 6002450 A AU 6582298 A CN 1251182 T EP 0970418 A	14-12-1999 20-10-1998 19-04-2000 12-01-2000