

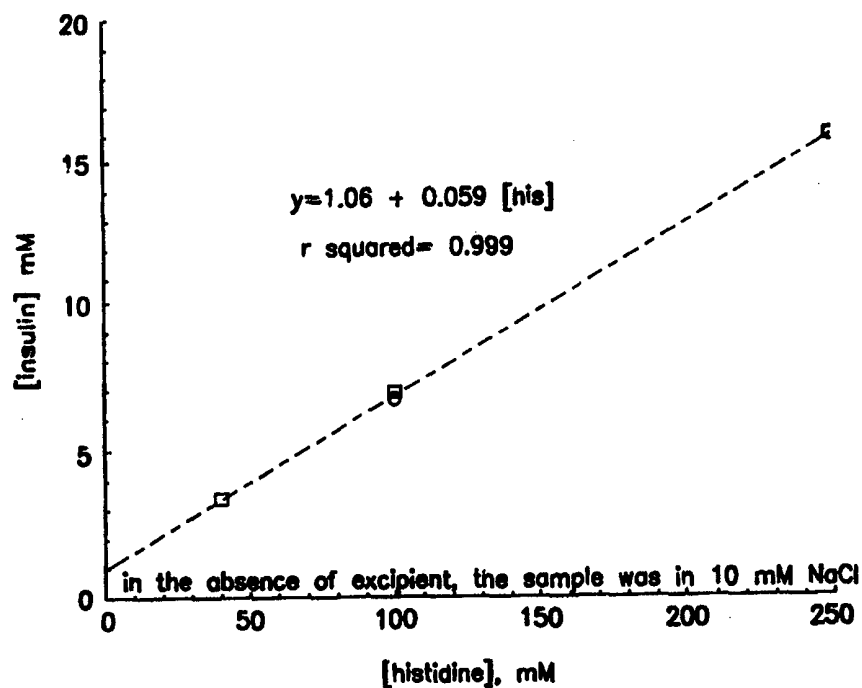

## INTERNATIONAL APPLICATION PUBLISHED UNDER THE PATENT COOPERATION TREATY (PCT)

|  |  |  |
|--|--|--|
| (51) International Patent Classification <sup>6</sup> :<br><b>A61K 47/18, 38/28</b>  | <b>A1</b>  | (11) International Publication Number: <b>WO 99/24071</b><br>(43) International Publication Date: 20 May 1999 (20.05.99) |
| <p>(21) International Application Number: PCT/US98/23298</p> <p>(22) International Filing Date: 3 November 1998 (03.11.98)</p> <p>(30) Priority Data:<br/>08/969,217 12 November 1997 (12.11.97) US</p> <p>(71) Applicant: ALZA CORPORATION [US/US]; 950 Page Mill Road, P.O. Box 10950, Palo Alto, CA 94303-0802 (US).</p> <p>(72) Inventor: LEUNG, Iris, Ka, Man; 14727 Greenleaf Valley Drive, Chesterfield, MO 63017-5514 (US).</p> <p>(74) Agents: MILLER, D., Byron et al.; Alza Corporation, 950 Page Mill Road, P.O. Box 10950, Palo Alto, CA 94303-0802 (US).</p> | <p>(81) Designated States: AL, AM, AT, AU, AZ, BA, BB, BG, BR, BY, CA, CH, CN, CU, CZ, DE, DK, EE, ES, FI, GB, GD, GE, GH, GM, HR, HU, ID, IL, IS, JP, KE, KG, KP, KR, KZ, LC, LK, LR, LS, LT, LU, LV, MD, MG, MK, MN, MW, MX, NO, NZ, PL, PT, RO, RU, SD, SE, SG, SI, SK, SL, TJ, TM, TR, TT, UA, UG, UZ, VN, YU, ZW, ARIPO patent (GH, GM, KE, LS, MW, SD, SZ, UG, ZW), Eurasian patent (AM, AZ, BY, KG, KZ, MD, RU, TJ, TM), European patent (AT, BE, CH, CY, DE, DK, ES, FI, FR, GB, GR, IE, IT, LU, MC, NL, PT, SE), OAPI patent (BF, BJ, CF, CG, CI, CM, GA, GN, GW, ML, MR, NE, SN, TD, TG).</p> <p><b>Published</b><br/><i>With international search report.</i><br/><i>Before the expiration of the time limit for amending the claims and to be republished in the event of the receipt of amendments.</i></p> |  |

(54) Title: METHOD FOR DECREASING SELF-ASSOCIATION OF POLYPEPTIDES



## (57) Abstract

Methods for decreasing the tendency for a polypeptide drug to self-associate are disclosed. The methods utilize histidine compounds and allow for more efficient delivery of polypeptide agents using transdermal delivery techniques.

**FOR THE PURPOSES OF INFORMATION ONLY**

Codes used to identify States party to the PCT on the front pages of pamphlets publishing international applications under the PCT.

|    |                          |    |  |    |  |    |                          |
|----|--------------------------|----|--|----|--|----|--------------------------|
| AL | Albania                  | ES | Spain                                    | LS | Lesotho                                      | SI | Slovenia                 |
| AM | Armenia                  | FI | Finland                                  | LT | Lithuania                                    | SK | Slovakia                 |
| AT | Austria                  | FR | France                                   | LU | Luxembourg                                   | SN | Senegal                  |
| AU | Australia                | GA | Gabon                                    | LV | Latvia                                       | SZ | Swaziland                |
| AZ | Azerbaijan               | GB | United Kingdom                           | MC | Monaco                                       | TD | Chad                     |
| BA | Bosnia and Herzegovina   | GE | Georgia                                  | MD | Republic of Moldova                          | TG | Togo                     |
| BB | Barbados                 | GH | Ghana                                    | MG | Madagascar                                   | TJ | Tajikistan               |
| BE | Belgium                  | GN | Guinea                                   | MK | The former Yugoslav<br>Republic of Macedonia | TM | Turkmenistan             |
| BF | Burkina Faso             | GR | Greece                                   |    |  | TR | Turkey                   |
| BG | Bulgaria                 | HU | Hungary                                  | ML | Mali   | TT | Trinidad and Tobago      |
| BJ | Benin                    | IE | Ireland                                  | MN | Mongolia                                     | UA | Ukraine                  |
| BR | Brazil                   | IL | Israel                                   | MR | Mauritania                                   | UG | Uganda                   |
| BY | Belarus                  | IS | Iceland                                  | MW | Malawi                                       | US | United States of America |
| CA | Canada                   | IT | Italy                                    | MX | Mexico                                       | UZ | Uzbekistan               |
| CF | Central African Republic | JP | Japan                                    | NE | Niger  | VN | Viet Nam                 |
| CG | Congo                    | KE | Kenya                                    | NL | Netherlands                                  | YU | Yugoslavia               |
| CH | Switzerland              | KG | Kyrgyzstan                               | NO | Norway                                       | ZW | Zimbabwe                 |
| CI | Côte d'Ivoire            | KP | Democratic People's<br>Republic of Korea | NZ | New Zealand                                  |    |                          |
| CM | Cameroon                 |    |  | PL | Poland                                       |    |                          |
| CN | China                    | KR | Republic of Korea                        | PT | Portugal                                     |    |                          |
| CU | Cuba                     | KZ | Kazakstan                                | RO | Romania                                      |    |                          |
| CZ | Czech Republic           | LC | Saint Lucia                              | RU | Russian Federation                           |    |                          |
| DE | Germany                  | LI | Liechtenstein                            | SD | Sudan  |    |                          |
| DK | Denmark                  | LK | Sri Lanka                                | SE | Sweden                                       |    |                          |
| EE | Estonia                  | LR | Liberia                                  | SG | Singapore                                    |    |                          |

1     METHOD FOR DECREASING SELF-ASSOCIATION OF POLYPEPTIDES

2

3     Technical Field

4                     The invention relates generally to transdermal drug delivery.  
5     More particularly, the invention relates to a method for decreasing self-  
6     association of polypeptides to aid in the transdermal delivery thereof.

7

8     Background of the Invention

9                     Transdermal (i.e., through the skin) delivery of therapeutic  
10    agents affords a comfortable, convenient and noninvasive technique for  
11    administering drugs. The method provides several advantages over  
12    conventional modes of drug delivery. For example, variable rates of  
13    absorption and (e.g., hepatic) metabolism encountered in oral treatment are  
14    avoided, and other inherent inconveniences -- e.g., gastrointestinal irritation  
15    and the like -- are eliminated. Transdermal delivery also allows a high degree  
16    of control over blood concentrations of a particular drug and is an especially  
17    attractive administration route for drugs with narrow therapeutic indexes, short  
18    half-lives and potent activities.

19                    Transdermal delivery can be either passive or active. Many  
20    drugs are not suitable for passive transdermal drug delivery because of their  
21    size, ionic charge characteristics and hydrophobicity. One method of  
22    overcoming this limitation is the use of low levels of electric current to actively  
23    transport drugs into the body through intact skin. This technique is known as  
24    "electrotransport" or "iontophoretic" drug delivery. The technique provides a  
25    more controllable process than passive transdermal drug delivery since the  
26    amplitude, timing and polarity of the applied electric current is easily regulated  
27    using standard electrical components. In this regard, electrotransport drug  
28    flux can be from 50% to several orders of magnitude greater than passive  
29    transdermal flux of the same drug.

1 Electrotransport devices generally employ at least two  
2 electrodes. Both of these electrodes are positioned in intimate electrical  
3 contact with some portion of the skin of the body. One electrode, called the  
4 active or donor electrode, is the electrode from which the therapeutic agent is  
5 delivered into the body. The other electrode, called the counter or return  
6 electrode, serves to close the electrical circuit through the body. In  
7 conjunction with the patient's skin, the circuit is completed by connection of  
8 the electrodes to a source of electrical energy, e.g., a battery, and usually to  
9 circuitry capable of controlling current passing through the device.

10 Depending upon the electrical charge of the species to be  
11 delivered transdermally, either the anode or cathode may be the active or  
12 donor electrode. Thus, if the ionic substance to be driven into the body is  
13 positively charged, the positive electrode (the anode) will be the active  
14 electrode and the negative electrode (the cathode) will serve as the counter  
15 electrode, completing the circuit. On the other hand, if the ionic substance to  
16 be delivered is negatively charged, the cathodic electrode will be the active  
17 electrode and the anodic electrode will be the counter electrode.  
18 Alternatively, both the anode and the cathode may be used to deliver drugs of  
19 appropriate charge into the body. In this case, both electrodes are  
20 considered to be active or donor electrodes. In other words, the anodic  
21 electrode can deliver positively charged agents into the body while the  
22 cathodic electrode can deliver negatively charged agents into the body.

23 Existing electrotransport devices additionally require a  
24 reservoir or source of the therapeutic agent that is to be delivered into the  
25 body. Such drug reservoirs are connected to the anode or the cathode of the  
26 electrotransport device to provide a fixed or renewable source of one or more  
27 desired species or agents. Examples of reservoirs and sources include a  
28 pouch as described in U.S. Patent No. 4,250,878 to Jacobsen; a pre-formed  
29 gel body as disclosed in U.S. Patent No. 4,382,529 to Webster; and a glass

1 or plastic container holding a liquid solution of the drug, as disclosed in the  
2 figures of U.S. Patent No. 4,722,726 to Sanderson et al.

3 Of particular interest herein is the transdermal delivery of  
4 peptides, polypeptides, and proteins because of the problems encountered  
5 with more common drug administration routes such as oral delivery.

6 Polypeptide and protein molecules are highly susceptible to degradation by  
7 proteolytic enzymes in the gastrointestinal tract and are subjected to an  
8 extensive hepatic metabolism when taken orally. Thus, these substances  
9 usually require parenteral administration to achieve therapeutic levels in the  
10 patient's blood. The most conventional parenteral administration techniques  
11 are hypodermic injections and intravenous administration. Polypeptides and  
12 proteins are, however, inherently short acting in their biological activity,  
13 requiring frequent injections, often several times a day, to maintain the  
14 therapeutically effective levels needed. Patients frequently find this treatment  
15 regimen to be inconvenient and painful. Such therapy also includes risk of,  
16 e.g., infection.

17 Much effort has been expended to find other routes (other  
18 than parenteral injections) for effective administration of pharmaceutical  
19 polypeptides and proteins. Administration routes with fewer side effects as  
20 well as better patient compliance have been of particular interest. Such  
21 alternative routes have generally included "shielded" oral administration  
22 wherein the polypeptide/protein is released from a capsule or other container  
23 after passing through the low pH environment of the stomach, delivery  
24 through the mucosal tissues, e.g., the mucosal tissues of the lung with  
25 inhalers or the nasal mucosal tissues with nasal sprays, and implantable  
26 pumps. Unfortunately, these alternative routes of polypeptide/protein delivery  
27 have met with only limited success.

28 A number of investigators have disclosed electrotransport  
29 delivery of polypeptides and proteins. An early study by R. Burnette et al. *J.*  
30 *Pharm. Sci.* (1986) 75:738, involved *in vitro* skin permeation of thyrotropin

1 releasing hormone, a small tripeptide molecule. The electrotransport flux was  
2 found to be higher than passive diffusional flux. Chien et al. *J. Pharm. Sci.*  
3 (1988) 78:376, in both *in vitro* and *in vivo* studies, showed that transdermal  
4 delivery of vasopressin and insulin via electrotransport was possible. See,  
5 also, Maulding et al., U.S. Statutory Invention Registration No. H1160, which  
6 discloses electrotransport delivery of calcitonin in minipigs.

7                   However, transdermal delivery of polypeptides and proteins  
8 has also encountered technical difficulties. For example, skin irritation can  
9 occur due to water hydrolysis at the interface between the electrode and the  
10 drug solution or electrolyte salt solution. The products of such hydrolysis,  
11 hydronium ions at the anode and hydroxyl ions at the cathode, compete with  
12 drug ions of like charge for delivery into the skin, altering skin pH and causing  
13 irritation. U.S. Patent No. 5,533,971, to Phipps et al., describes this problem  
14 in more detail and reports the use of amino acid buffers, including histidine  
15 buffers, for reducing skin irritation.

16                   Additionally, certain polypeptides, particularly those that are  
17 not native to the animal being treated, may cause skin reactions, e.g.,  
18 sensitization or irritation. Many polypeptides are also unstable and degrade  
19 rapidly. In this regard, International Publication No. WO 93/12812, published  
20 8 July 1993, describes the use of histidine buffers to chemically stabilize  
21 growth hormone formulations. Furthermore, certain polypeptide drugs rapidly  
22 aggregate in aqueous solution which can cause both delivery and solubility  
23 problems.

24                   For example, aqueous insulin, at concentrations relevant for  
25 pharmaceutical formulations, has a tendency to form dimers, which in turn  
26 self-associate into tetramers, hexamers, stacked hexamers and other  
27 polymeric species, with a concomitant decrease in solubility. These  
28 aggregates can obstruct mechanical parts of continuous delivery devices and  
29 are difficult, if not impossible, to deliver transdermally. This tendency is

1 exacerbated by the presence of metal ions, such as zinc, traditionally used in  
2 insulin formulations to stabilize and prolong the activity of insulin.

3           Attempts have been made to decrease self-association of  
4 proteins such as insulin. For example, Ogiso et al., *Biol. Pharm. Bull.* (1996)  
5 19:1049-1054, report the use of a Gly-HCl buffer to promote dissociation of  
6 porcine insulin oligomers prior to percutaneous absorption thereof. Bringer et  
7 al., *Diabetes* (1981) 30:83-85 report that the dicarboxylic amino acids, Asp  
8 and Glu, at their isoelectric pH, reduce aggregation of insulin in solution. The  
9 experimenters explain that acid pH (3.5) seems necessary in order for  
10 aggregation to be retarded using these amino acids. However, insulin is  
11 chemically unstable in acid. U.S. Patent No. 4,940,456, to Sibalís et al.,  
12 describes insulin compositions for electrolytic transdermal transport which  
13 include urea, propylurea, potassium iodide, sodium perchlorate or guanidine  
14 hydrochloride as dissociating agents.

15           Insulin analogs have also been developed that reportedly  
16 have decreased tendencies toward self-association. For example, U.S.  
17 Patent No. 5,164,366, to Balschmidt et al., describes insulin analogs with  
18 deletions of certain amino acids, such as Phe<sup>B24</sup> or Phe<sup>B25</sup>. International  
19 Publication No. WO 92/12999, published 6 August 1992, describes human  
20 insulin analogs with selected amino acid residues substituted with Asp and  
21 Glu residues. EP Patent Publication No. 214,826 B1, published 18 March  
22 1987, reports insulin analogs having amino acid substitutions, particularly in  
23 the B9-B12 region and the B26-B28 positions, wherein the residue  
24 substituted for the natural amino acid is more hydrophilic. Preferred amino  
25 acid substitutions include Asp, Glu, Ser, Thr, His and Ile. However, many of  
26 these analogs display reduced biological activity.

27           Thus, alternative methods for decreasing self-association of  
28 polypeptide drugs such as insulin, in the context of transdermal delivery,  
29 would be desirable.

30

1 Disclosure of the Invention

2                   Accordingly, the present invention provides a method for  
3 preventing self-association of insulin and other bioactive polypeptides while at  
4 the same time aiding in solubilization of such molecules. The method uses  
5 histidine compounds and, by virtue of the decrease of self-association, allows  
6 for more efficient delivery of proteins transdermally, such as by  
7 electrotransport and passive transdermal delivery, in therapeutically effective  
8 amounts.

9                   Accordingly, in one embodiment, the invention relates to a  
10 method of decreasing oligomer formation of a polypeptide. The method  
11 comprises combining the polypeptide with an amount of a histidine compound  
12 sufficient to decrease the tendency of said polypeptide to self-associate. In  
13 particularly preferred methods, the histidine compound is L-histidine or L-  
14 glycyl-histidine and the polypeptide is an insulin compound, with or without  
15 zinc, such as a zinc-free human insulin compound or a human Lys<sup>B28</sup>Pro<sup>B29</sup>  
16 insulin analog.

17                   In another embodiment, the subject invention is directed to  
18 a method of decreasing formation of hexamers and larger species of a human  
19 insulin compound. The method comprises combining the insulin compound  
20 with a histidine compound at about pH 7 to about pH 8. The concentration of  
21 histidine is at least about 10 mmolar (mM).

22                   In yet another embodiment, the invention is directed to a  
23 method for delivering a polypeptide agent through a body surface by  
24 electrotransport. The method comprises:

25                   (a) providing a composition comprising the polypeptide and  
26 a histidine compound, wherein the histidine compound is present in the  
27 composition in an amount sufficient to decrease the tendency of the  
28 polypeptide to self-associate; and

29                   (b) delivering the composition through the body surface by  
30 electrotransport.

1 In another embodiment, the invention is directed to a  
2 method for delivering a human insulin compound through a body surface by  
3 electrotransport. The method comprises:

4 (a) providing a composition comprising the insulin  
5 compound and a histidine compound at about pH 7 to about pH 8, wherein  
6 the concentration of the histidine compound is about 10 mmolar to about 250  
7 mmolar;

8 (b) delivering the composition through the body surface by  
9 electrotransport.

10 In yet another embodiment, the invention is directed to a  
11 method for administering a human insulin compound through a body surface  
12 by passive transdermal delivery. The method comprises:

13 (a) providing a composition comprising said insulin  
14 compound and a histidine compound, wherein said histidine compound is  
15 present in said composition in an amount sufficient to decrease the tendency  
16 of said insulin to self-associate; and

17 (b) administering said composition through the body  
18 surface by passive transdermal delivery.

19 These and other embodiments of the subject invention will  
20 readily occur to those of skill in the art in light of the disclosure herein.

21

## 22 Brief Description of the Drawings

23 Figure 1 shows the effect of increasing histidine  
24 concentration on the solubility of wild-type human insulin with two zinc bound  
25 per hexamer at pH 7.5.

26 Figure 2 is a schematic view of a representative  
27 electrotransport drug delivery device which can be used with the present  
28 invention.

1                   Figure 3 is a cross-sectional view of a representative  
2 passive transdermal drug delivery device which can be used with the present  
3 invention.

4                   Figure 4 is a cross-sectional view of an alternate passive  
5 transdermal drug delivery device which can be used with the present  
6 invention.

7                   Figure 5 is a graph depicting the average molecular weights  
8 of zinc-free Lys<sup>B28</sup>Pro<sup>B29</sup> human insulin as a function of insulin concentration  
9 for the 240 mM histidine data taken from Table III in the examples.

10                  Figure 6 is a graph depicting the average molecular weights  
11 of zinc-free Lys<sup>B28</sup>Pro<sup>B29</sup> human insulin as a function of insulin concentration  
12 for the 0 mM histidine data taken from Table III in the examples.

13                  Figure 7 is a graph depicting the average molecular weights  
14 of zinc-free wild-type human insulin as a function of insulin concentration for  
15 the 240 mM histidine data taken from Table IV in the examples.

16                  Figure 8 is a graph depicting the average molecular weights  
17 of zinc-free wild-type human insulin as a function of insulin concentration for  
18 the 0 mM histidine data taken from Table IV in the examples.

19

#### 20 Detailed Description of the Invention

21                  The practice of the present invention will employ, unless  
22 otherwise indicated, conventional methods of protein chemistry,  
23 electrochemistry and biochemistry within the skill of the art. Such techniques  
24 are explained fully in the literature. See, e.g., T.E. Creighton, *Proteins:  
25 Structures and Molecular Properties* (W.H. Freeman and Company, 1993);  
26 A.L. Lehninger, *Biochemistry* (Worth Publishers, Inc., 1975); J.S. Newman,  
27 *Electrochemical Systems* (Prentice Hall, 1973); and A.J. Bard and L.R.  
28 Faulkner, *Electrochemical Methods, Fundamentals and Applications* (John  
29 Wiley & Sons, 1980).

1 It must be noted that, as used in this specification and the  
2 appended claims, the singular forms "a", "an" and "the" include plural  
3 referents unless the content clearly dictates otherwise. Thus, for example,  
4 reference to "a polypeptide" includes a mixture of two or more polypeptides,  
5 and the like.

6 The following amino acid abbreviations are used throughout  
7 the text:

|                           |                        |
|---------------------------|------------------------|
| 8 Alanine: Ala (A)        | Arginine: Arg (R)      |
| 9 Asparagine: Asn (N)     | Aspartic acid: Asp (D) |
| 10 Cysteine: Cys (C)      | Glutamine: Gln (Q)     |
| 11 Glutamic acid: Glu (E) | Glycine: Gly (G)       |
| 12 Histidine: His (H)     | Isoleucine: Ile (I)    |
| 13 Leucine: Leu (L)       | Lysine: Lys (K)        |
| 14 Methionine: Met (M)    | Phenylalanine: Phe (F) |
| 15 Proline: Pro (P)       | Serine: Ser (S)        |
| 16 Threonine: Thr (T)     | Tryptophan: Trp (W)    |
| 17 Tyrosine: Tyr (Y)      | Valine: Val (V)        |

18

### 19 I. Definitions

20 In describing the present invention, the following terms will  
21 be employed, and are intended to be defined as indicated below.

22 The terms "polypeptide," "polypeptide agent" and  
23 "polypeptide drug" are used interchangeably herein to denote any bioactive  
24 polymer of amino acid residues. The terms encompass peptides,  
25 oligopeptides, dimers, multimers, and the like. Such polypeptides can be  
26 derived from natural sources or can be synthesized or recombinantly  
27 produced. The terms also include postexpression modifications of the  
28 polypeptide, for example, glycosylation, acetylation, phosphorylation, etc.

29 A polypeptide drug or agent as defined herein is generally  
30 made up of one or more of the 20 natural amino acids, listed above and may

1 also include any of the several known amino acid analogs, both naturally  
2 occurring and synthesized analogs, such as but not limited to  
3 homoisoleucine, 2-(methylenecyclopropyl)glycine, S-methylcysteine, S-(prop-  
4 l-enyl)cysteine, homoserine, ornithine, norleucine, norvaline, homoarginine, 3-  
5 (3-carboxyphenyl)alanine, cyclohexylalanine, mimosine, pipercolic acid, 4-  
6 methylglutamic acid, canavanine, 2,3-diaminopropionic acid, and the like.  
7 The polypeptide can also exist in neutral or salt forms, e.g., acid addition salts  
8 (formed with the free amino groups of the analog polypeptides) and which are  
9 formed with inorganic acids such as, for example, hydrochloric or phosphoric  
10 acids, or such organic acids as acetic, succinic, maleic, tartaric, mandelic, and  
11 the like. Salts formed from free carboxyl groups may also be derived from  
12 inorganic bases such as, for example, sodium, potassium, ammonium,  
13 calcium, or ferric hydroxides, and such organic bases as isopropylamine,  
14 trimethylamine, 2-ethylamino ethanol, histidine, and the like. Examples of  
15 polypeptide agents which will find use in the present invention are set forth  
16 below.

17                   The term "insulin compound" as used herein refers to a  
18 compound having a molecular structure similar or identical to native insulin or  
19 proinsulin, including a molecule with similar or identical tertiary conformation  
20 to native insulin or proinsulin, and which retains insulin activity, i.e., the ability  
21 to regulate blood glucose levels. Such compounds may include amino acid  
22 additions, substitutions and deletions, relative to the native molecule, so long  
23 as the modifications do not destroy insulin activity. Examples of insulin  
24 compounds with amino acid substitutions relative to native insulin include  
25 Lys<sup>B28</sup>Pro<sup>B29</sup> human insulin and Asp<sup>B28</sup> human insulin. Furthermore, for  
26 purposes of the present invention, an insulin compound may be derived from  
27 any mammalian source, such as human, bovine, canine, equine, ovine,  
28 porcine, cetacean, etc. The insulin compound may be purified directly from  
29 the pancreas of the source organism, or may be recombinantly or  
30 synthetically produced. See, e.g., Brange, J. *Galenics of Insulin, The*

1 *Physico-chemical and Pharmaceutical Aspects of Insulin and Insulin*  
2 *Preparations* (Springer-Verlag) for various methods of obtaining insulin.

3                   Additionally, the term "insulin compound" as used herein  
4 denotes an insulin compound with or without associated metals. In this  
5 regard, it has been found that metals, such as zinc and calcium, prolong the  
6 activity of insulin as well as increase physical stability of the molecule. Thus,  
7 an insulin compound for use in the present methods includes, without  
8 limitation, metal-free insulin, as well as insulin in association with an  
9 appropriate metal, including but not limited to insulin having from about 2 Zn<sup>2+</sup>  
10 molecules/hexamer to about 4 Zn<sup>2+</sup> molecules/hexamer. See, e.g., U.S.  
11 Patent No. 4,476,118, for a description of such compounds, as well as  
12 methods of making the same. Further examples of insulin compounds for use  
13 with the present invention are described more fully below.

14                   The term "histidine compound" as used herein refers to the  
15 amino acid L-His, as well as amino acid analogs of L-His which retain the  
16 ability to decrease oligomer formation of a given polypeptide, as defined  
17 below. Such analogs include, without limitation, dipeptides and tripeptides  
18 which contain His, such as but not limited to, His-Gly, Gly-His, Ala-His, 3  
19 methyl-His, 1 methyl-His, carnosine, His-Ser and His-Ala.

20                   A histidine compound "decreases oligomer formation" of a  
21 given polypeptide when self-association of the polypeptide resulting in  
22 oligomers, such as tetramers, hexamers, stacked hexamers, and other  
23 polymers, is either retarded (e.g., oligomer formation is at least partially  
24 prevented), or reversed (e.g., already aggregated polypeptides are  
25 dissociated), by the presence of the histidine compound. The ability of a  
26 histidine compound to decrease oligomer formation can be determined by  
27 assessing the presence of oligomeric species in the presence and absence of  
28 the histidine compound in question. Such formation can be determined using  
29 analytical ultracentrifugation (see, e.g., *Modern Analytical Ultracentrifugation*,  
30 Schuster and Laue eds. 1994, Birkh@user; and *Analytical Ultracentrifugation*

1    *in Biochemistry and Polymer Science*, Harding, Rowe and Horton eds., 1992,  
2    The Royal Society of Chemistry), such as sedimentation equilibrium studies  
3    as described in the examples, spectrophotometric determinations (see, e.g.,  
4    Ogiso et al., *Biol. Pharm. Bull.* (1996) 19:1049-1054), osmometry, gel  
5    filtration, and the like. For a description of such methods, see, e.g., Valdes  
6    and Ackers, *Methods in Enzymology*, Vol. 61 (Enzyme Structure, part H, Hirs  
7    and Timasheff, eds.) Academic Press, 1979, pp. 125-142.

8                   The term "passive transdermal delivery" refers to the  
9    delivery through a body surface (e.g., skin) of one or more pharmaceutically  
10   active polypeptide agents to be available for distribution via the systemic  
11   circulation, without the aid of an applied electromotive force. Passive  
12   transdermal delivery can be accomplished using a number of means  
13   including, without limitation, direct application to the skin, transdermal  
14   patches, membrane-moderated systems to provide controlled delivery,  
15   adhesive diffusion-controlled systems, matrix dispersion-type systems, and  
16   microreservoir systems. Such systems are known in the art and are  
17   discussed in detail in *Remington: The Science and Practice of Pharmacy*,  
18   Mack Publishing Company, Easton, Pennsylvania, 19th edition, 1995.  
19   Penetration enhancers can be used to facilitate absorption through the skin.  
20   Such penetration enhancers include solvents such as water, alcohols  
21   including methanol, ethanol, 2-propanol and the like, alkyl methyl sulfoxides,  
22   pyrrolidones, laurocapram, acetone, dimethylacetamide, dimethyl formamide,  
23   tetrahydrofurfuryl; surfactants; and chemicals such as urea, N,N-diethyl-m-  
24   toluamide, and the like.

25                   The terms "electrotransport", "iontophoresis", and  
26   "iontophoretic" are used herein to refer to the delivery through a body surface  
27   (e.g., skin) of one or more pharmaceutically active polypeptide agents by  
28   means of an applied electromotive force to an agent-containing reservoir.  
29   The agent may be delivered by electromigration, electroporation,  
30   electroosmosis or any combination thereof. Electroosmosis has also been

1 referred to as electrohydrokinesis, electro-convection, and electrically induced  
2 osmosis. In general, electroosmosis of a species into a tissue results from  
3 the migration of solvent in which the species is contained, as a result of the  
4 application of electromotive force to the therapeutic species reservoir, i.e.,  
5 solvent flow induced by electromigration of other ionic species. During the  
6 electrotransport process, certain modifications or alterations of the skin may  
7 occur such as the formation of transiently existing pores in the skin, also  
8 referred to as "electroporation". Any electrically assisted transport of species  
9 enhanced by modifications or alterations to the body surface (e.g., formation  
10 of pores in the skin) are also included in the term "electrotransport" as used  
11 herein. Thus, as used herein, the terms "electrotransport", "iontophoresis"  
12 and "iontophoretic" refer to (1) the delivery of charged agents by  
13 electromigration, (2) the delivery of uncharged agents by the process of  
14 electroosmosis, (3) the delivery of charged or uncharged agents by  
15 electroporation, (4) the delivery of charged agents by the combined  
16 processes of electromigration and electroosmosis, and/or (5) the delivery of a  
17 mixture of charged and uncharged agents by the combined processes of  
18 electromigration and electroosmosis.

19 A polypeptide shows "enhanced electrotransport" when  
20 electrotransport flux of the polypeptide through the body surface (e.g., the  
21 skin or mucosa) is increased in the presence of a histidine compound, as  
22 compared to the flux in the absence of the histidine compound, as determined  
23 using standard methods of measurement. For example, transdermal  
24 electrotransport flux can be assessed using a number of *in vivo* or *in vitro*  
25 methods, well known in the art. *In vitro* methods include clamping a piece of  
26 skin of an appropriate animal (e.g., human cadaver skin) between the donor  
27 and receptor compartments of an electrotransport flux cell, with the stratum  
28 corneum side of the skin piece facing the donor compartment. A liquid  
29 solution or gel containing the drug to be delivered is placed in contact with the  
30 stratum corneum, and electric current is applied to electrodes, one electrode

1 in each compartment. The transdermal flux is calculated by sampling the  
2 amount of drug in the receptor compartment. Two successful models used to  
3 optimize transdermal electrotransport drug delivery are the isolated pig skin  
4 flap model of Riviere, Heit et al, *J. Pharm. Sci.* (1993) 82:240-243, and the  
5 use of isolated hairless skin from hairless rodents or guinea pigs. See,  
6 Hadzija et al., *J. Pharm. Pharmacol.* (1992) 44:387-390. See, also, Ogiso et  
7 al., *Biol. Pharm. Bull.* (1996) 19:1049-1054, for a description of a method for  
8 evaluating percutaneous absorption of insulin.

9

## 10 II. Modes of Carrying Out the Invention

11 The present invention concerns the use of histidine  
12 compounds to decrease self-association of a polypeptide molecule, thereby  
13 enhancing transdermal delivery of the polypeptide molecule as compared to  
14 the delivery of the untreated polypeptide. The method therefore permits  
15 increased efficiency of the transdermal delivery of a large number of  
16 substances, and allows for the transdermal delivery of molecules that would  
17 not otherwise be amenable to such delivery. Additionally, the method  
18 increases the solubility of the polypeptide agent so treated and decreases the  
19 potential for immunological reactions that might occur against aggregates of  
20 otherwise endogenous substances.

21 The present invention will find use with a wide variety of  
22 proteins and polypeptide agents that have the tendency to aggregate, such  
23 as a number of polypeptides derived from eucaryotic, procaryotic and viral  
24 sources, as well as synthetic peptides. Such polypeptides include without  
25 limitation, peptide drugs which are antibiotics and antiviral agents,  
26 antineoplastics, immunomodulators, peptide hormones such as insulin,  
27 proinsulin, growth hormone, GHRH, LHRH, EGF, Somatostatin, SNX-111,  
28 BNP, insulinotropin, ANP, and glycoprotein hormones such as, FSH, LH, PSH  
29 and hCG.

1                   The present invention has been exemplified using insulin  
2 and insulin analogs but is not limited to insulin compounds. Insulin was  
3 chosen to illustrate the invention based on its tendency to self-associate into  
4 hexameric and polymeric structures termed "stacked hexamers." Such  
5 association inhibits transdermal delivery of the polypeptide and can cause  
6 irritation at the delivery site.

7                   Examples of insulin compounds for use with the present  
8 methods include any commercially available insulins, such as, for example,  
9 recombinant human insulin from Sigma, St. Louis, MO, formulated as neutral  
10 solutions or suspensions of zinc insulin. Such preparations of insulin contain  
11 a minimum of two zinc ions bound per hexamer and have an insulin  
12 concentration from about 0.2 to about 3.0 mM (1 mg mL<sup>-1</sup> to 18 mg mL<sup>-1</sup>).  
13 However, insulin preparations including higher concentrations of insulin, up to  
14 about 17 mM insulin will also find use herein. Insulin devoid of metals such  
15 as zinc can also be used with the present methods and the concentration can  
16 range from about 0.1 to 30 mM. Insulin analogs for use as the insulin  
17 compound herein include commercially available human insulin analogs such  
18 as a Lys<sup>B28</sup> and Pro<sup>B29</sup> insulin, available from Lilly (Indianapolis, IN) as  
19 Humalog® insulin lispro injection, described further in the examples; insulin  
20 compounds containing protamine, such as NPH (Neutral Protamine  
21 Hagedorn) and isophane insulin (available from various manufacturers); and  
22 Lente and Biphasic insulins (available from various manufacturers). See,  
23 e.g., *Remington: The Science and Practice of Pharmacy*, Mack Publishing  
24 Company, Easton, Pennsylvania, 19th edition, 1995, for a description of  
25 these and other insulin compounds.

26                   Other insulin analogs for use herein include, but are not  
27 limited to, analogs such as those described by Marki et al., *Z. Physiol. Chem.*  
28 (1979) 360:1619-1632, substituted at amino acid positions 2, 5, 6, 7, 8 and 11  
29 of the A-chain and 5, 7, 13 and 16, of the B-chain; sulphated insulins such as  
30 those described by Albisser et al., in U.S. Pharmacopeial Convention,

1 Rockville, MD. (Gueriguian et al., eds.) pp. 84-95; Des-Phe insulin (having  
2 the N-terminal amino acid of the B-chain deleted); insulin analogs with  
3 additional deletions of certain amino acids, such as deletion of Phe<sup>B24</sup> or  
4 Phe<sup>B25</sup> (U.S. Patent No. 5,164,366, to Balschmidt et al.); insulin analogs  
5 having amino acid substitutions, particularly in the B9-B12 region and the  
6 B26-B28 positions, wherein the residue substituted for the natural amino acid  
7 is more hydrophilic and is generally Asp, Glu, Ser, Thr, His and Ile (EP Patent  
8 Publication No. 214,826 B1, published 18 March 1987); human insulin  
9 analogs with selected amino acid residues substituted with Asp and Glu  
10 residues (International Publication No. WO 92/12999, published 6 August  
11 1992), and the like.

12 Histidine compounds for use with the present invention  
13 include L-His, and analogs thereof, such as but not limited to, dipeptides and  
14 tripeptides which contain His, such as His-Gly, Gly-His, Ala-His, 3 methyl-His,  
15 1 methyl-His, L-carnosine (also known as  $\beta$ -Ala-His), His-Ser and His-Ala.  
16 The choice of an appropriate histidine compound is within the skill in the art  
17 and will be determined based largely on the particular polypeptide in question.

18 The histidine compound will generally be present at its  
19 isoelectric point and in a concentration of from about 1 mM to 330 mM, more  
20 preferably about 10 mM to about 250 mM, and most preferably about 25 mM  
21 to about 250 mM. The optimal histidine concentration is dependent on a  
22 number of factors including insulin concentration, concentration of other salts  
23 (e.g., NaCl), the presence or absence of zinc, the presence or absence of  
24 preservatives, the tendency of the polypeptide to form oligomers, and the like.

25 In general, the concentration of histidine is at least about 10 mM. Those  
26 skilled in the art of protein formulations can easily determine the optimal  
27 histidine concentration for the particular variables (e.g., insulin concentration,  
28 salt concentration, presence or absence of zinc, preservative or no  
29 preservative) used in a particular application or formulation.

1                   The polypeptide will be present in a therapeutically effective  
2 amount, that is, an amount sufficient to achieve the desired therapeutic result.

3     The exact amount required will vary from subject to subject, depending on  
4 the species, age, and general condition of the subject, the severity of the  
5 condition being treated, and the particular polypeptide drug of interest.  
6 Therapeutically effective doses are easily determined by one of skill in the art  
7 using e.g., standard dose response curves and the like. For example, if the  
8 polypeptide is insulin, it will normally be present in a concentration from about  
9 0.1 to about 30 mM, more preferably 0.2 to about 20 mM and most preferably  
10 about 0.3 to about 17 mM, the concentration depending on the particular  
11 insulin compound used and whether the molecule includes bound zinc.

12                   When L-His is used along with a commercially available  
13 human insulin, which generally includes insulin in the form of hexamers and  
14 stacked hexamers, insulin will usually be present in a concentration of about  
15 0.2 mM to about 17 mM (1 mg mL<sup>-1</sup> to 100 mg mL<sup>-1</sup>) and L-His present in a  
16 concentration of about 25-250 mM. One of skill in the art can readily  
17 determine the appropriate amount of insulin and L-His for use in the method  
18 of the invention.

19                   Polypeptide drugs for use in the present invention may be  
20 negatively charged, positively charged, or neutral, the choice of which will  
21 depend on, among other factors, the particular histidine compound used, as  
22 well as the desired pH. Determination of these parameters is well within the  
23 skill in the art. For example, when L-His is used as the histidine compound  
24 and the pH of the composition is 7-8, the insulin compound will be negatively  
25 charged.

26                   Generally, the pH of the final solution will be from about pH  
27 6 to about pH 8.5, more preferably pH 7 to about pH 8. However, the pH of  
28 the solution can vary depending again on the particular polypeptide and  
29 histidine compound used in the method.

1                   The polypeptide and histidine compounds are generally  
2 present in pharmaceutically acceptable excipients such as water, saline,  
3 aqueous dextrose, glycerol, ethanol, and the like, to thereby form a solution or  
4 suspension. If desired, the pharmaceutical composition to be administered  
5 may also contain minor amounts of nontoxic auxiliary substances such as  
6 wetting or emulsifying agents, preservatives, pH buffering agents and the like,  
7 for example, sodium acetate, sorbitan monolaurate, triethanolamine sodium  
8 acetate, triethanolamine oleate, etc. The choice of an appropriate excipient  
9 and additives is determined largely by the polypeptide and histidine  
10 compounds being used. For a discussion of polypeptide formulations, see,  
11 e.g., *Remington: The Science and Practice of Pharmacy*, Mack Publishing  
12 Company, Easton, Pennsylvania, 19th edition, 1995.

13                   For insulin formulations, such substances include, without  
14 limitation, preservatives such as methylparaben and phenol (*m*-cresol);  
15 isotonic agents such as glycerol or salts, including but not limited to NaCl  
16 (generally at a concentration of about 1 to about 100 mM NaCl); and other  
17 additives and buffering agents such as sodium acetate, NaPO<sub>4</sub>, and the like.  
18 For a discussion of insulin formulations, see, e.g., Brange, J., *Stability of*  
19 *Insulin* (Kluwer Academic Publishers); Brange, J. *Galenics of Insulin, The*  
20 *Physico-chemical and Pharmaceutical Aspects of Insulin and Insulin*  
21 *Preparations* (Springer-Verlag); and *Remington: The Science and Practice of*  
22 *Pharmacy*, Mack Publishing Company, Easton, Pennsylvania, 19th edition,  
23 1995.

24                   Once the desired polypeptide formulation with histidine is  
25 prepared, it can be delivered to the subject using any of several transdermal  
26 drug delivery systems and delivery is not limited to the use of one particular  
27 system. Examples of electrotransport drug delivery systems are described in,  
28 e.g., U.S. Patent Nos. 5,312,326 to Myers et al., 5,080,646 to Theeuwes et  
29 al., 5,387,189 to Gyory et al., and 5,169,383 to Gyory et al., the disclosures of  
30 which are incorporated by reference herein.

1                   Figure 2 illustrates a representative electrotransport delivery  
2 device that may be used in conjunction with the present method. Device **10**  
3 comprises an upper housing **16**, a circuit board assembly **18**, a lower housing  
4 **20**, anode electrode **22**, cathode electrode **24**, anode reservoir **26**, cathode  
5 reservoir **28** and skin-compatible adhesive **30**. Upper housing **16** has lateral  
6 wings **15** which assist in holding device **10** on a patient's skin. Upper housing  
7 **16** is preferably composed of an injection moldable elastomer (e.g., ethylene  
8 vinyl acetate). Printed circuit board assembly **18** comprises an integrated  
9 circuit **19** coupled to discrete components **40** and battery **32**. Circuit board  
10 assembly **18** is attached to housing **16** by posts (not shown in Figure 2)  
11 passing through openings **13a** and **13b**, the ends of the posts being  
12 heated/melted in order to heat stake the circuit board assembly **18** to the  
13 housing **16**. Lower housing **20** is attached to the upper housing **16** by means  
14 of adhesive **30**, the upper surface **34** of adhesive **30** being adhered to both  
15 lower housing **20** and upper housing **16** including the bottom surfaces of  
16 wings **15**.

17                   Shown (partially) on the underside of circuit board assembly  
18 **18** is a button cell battery **32**. Other types of batteries may also be employed  
19 to power device **10**.

20                   The device **10** is generally comprised of battery **32**,  
21 electronic circuitry **19,40**, electrodes **22,24**, and drug/chemical reservoirs  
22 **26,28**, all of which are integrated into a self-contained unit. The outputs (not  
23 shown in Figure 2) of the circuit board assembly **18** make electrical contact  
24 with the electrodes **24** and **22** through openings **23,23'** in the depressions  
25 **25,25'** formed in lower housing **20**, by means of electrically conductive  
26 adhesive strips **42,42'**. Electrodes **22** and **24**, in turn, are in direct mechanical  
27 and electrical contact with the top sides **44',44** of drug reservoirs **26** and **28**.  
28 The bottom sides **46',46** of drug reservoirs **26,28** contact the patient's skin  
29 through the openings **29',29** in adhesive **30**.

1 Device **10** optionally has a feature which allows the patient  
2 to self-administer a dose of drug by electrotransport. Upon depression of  
3 push button switch **12**, the electronic circuitry on circuit board assembly **18**  
4 delivers a predetermined DC current to the electrodes/reservoirs **22,26** and  
5 **24,28** for a delivery interval of predetermined length. The push button switch  
6 **12** is conveniently located on the top side of device **10** and is easily actuated  
7 through clothing. A double press of the push button switch **12** within a short  
8 time period, e.g., three seconds, is preferably used to activate the device for  
9 delivery of drug, thereby minimizing the likelihood of inadvertent actuation of  
10 the device **10**. Preferably, the device transmits to the user a visual and/or  
11 audible confirmation of the onset of the drug delivery interval by means of  
12 LED **14** becoming lit and/or an audible sound signal from, e.g., a "beeper".  
13 Drug is delivered through the patient's skin by electrotransport, e.g., on the  
14 arm, over the predetermined delivery interval.

15 Anodic electrode **22** is preferably comprised of silver and  
16 cathodic electrode **24** is preferably comprised of silver chloride. Both  
17 reservoirs **26** and **28** are preferably comprised of polymer hydrogel materials.  
18 Electrodes **22,24** and reservoirs **26,28** are retained within the depressions  
19 **25',25** in lower housing **20**.

20 The push button switch **12**, the electronic circuitry on circuit  
21 board assembly **18** and the battery **32** are adhesively "sealed" between upper  
22 housing **16** and lower housing **20**. Upper housing **16** is preferably composed  
23 of rubber or other elastomeric material. Lower housing **20** is preferably  
24 composed of a plastic or elastomeric sheet material (e.g., polyethylene) which  
25 can be easily molded to form depressions **25,25'** and cut to form openings  
26 **23,23'**. The assembled device **10** is preferably water resistant (i.e., splash  
27 proof) and is most preferably waterproof. The system has a low profile that  
28 easily conforms to the body, thereby allowing freedom of movement at, and  
29 around, the wearing site. The reservoirs **26** and **28** are located on the skin-

1 contacting side of the device **10** and are sufficiently separated to prevent  
2 accidental electrical shorting during normal handling and use.

3 The device **10** adheres to the patient's body surface (e.g.,  
4 skin) by means of a peripheral adhesive **30** which has upper side **34** and  
5 body-contacting side **36**. The adhesive side **36** has adhesive properties  
6 which assures that the device **10** remains in place on the body during normal  
7 user activity, and yet permits reasonable removal after the predetermined  
8 (e.g., 24-hour) wear period. Upper adhesive side **34** adheres to lower  
9 housing **20** and retains lower housing **20** attached to upper housing **16**.

10 The reservoirs **26** and **28** generally comprise a gel matrix,  
11 with the drug solution uniformly dispersed in at least one of the reservoirs **26**  
12 and **28**. Drug concentrations in the range of approximately  $1 \times 10^{-4}$  M to 1.0  
13 M or more can be used, with drug concentrations in the lower portion of the  
14 range being preferred. Suitable polymers for the gel matrix may comprise  
15 essentially any nonionic synthetic and/or naturally occurring polymeric  
16 materials. A polar nature is preferred when the active agent is polar and/or  
17 capable of ionization, so as to enhance agent solubility. Optionally, the gel  
18 matrix will be water swellable. Examples of suitable synthetic polymers  
19 include, but are not limited to, poly(acrylamide), poly(2-hydroxyethyl acrylate),  
20 poly(2-hydroxypropyl acrylate), poly(N-vinyl-2-pyrrolidone), poly(n-methylol  
21 acrylamide), poly(diacetone acrylamide), poly(2-hydroxyethyl methacrylate),  
22 poly(vinyl alcohol) and poly(allyl alcohol). Hydroxyl functional condensation  
23 polymers (i.e., polyesters, polycarbonates, polyurethanes) are also examples  
24 of suitable polar synthetic polymers. Polar naturally occurring polymers (or  
25 derivatives thereof) suitable for use as the gel matrix are exemplified by  
26 cellulose ethers, methyl cellulose ethers, cellulose and hydroxylated cellulose,  
27 methyl cellulose and hydroxylated methyl cellulose, gums such as guar,  
28 locust, karaya, xanthan, gelatin, and derivatives thereof. Ionic polymers can  
29 also be used for the matrix provided that the available counterions are either

1 drug ions or other ions that are oppositely charged relative to the active  
2 agent.

3 Thus, the polypeptide/histidine formulations of the present  
4 invention will be incorporated into the drug reservoir, e.g., a gel matrix as just  
5 described, and administered to a patient using an electrotransport drug  
6 delivery system, optionally as exemplified hereinabove. Incorporation of the  
7 drug solution can be done any number of ways, i.e., by imbibing the solution  
8 into the reservoir matrix, by admixing the drug solution with the matrix  
9 material prior to hydrogel formation, or the like.

10 In other embodiments of the present invention, passive  
11 transdermal delivery can be used to administer the polypeptide/histidine  
12 formulations of the present invention. It will be appreciated by those working  
13 in the field that the present invention can be used in conjunction with a wide  
14 variety of passive transdermal systems, as the invention is not limited in this  
15 regard. For examples of passive systems, reference may be had to, but not  
16 limited to, U.S. Patent Nos. 4,379,454 to Campbell et al., 4,588,580 to Gale et  
17 al., 4,832,953 to Campbell et al., 4,698,062 to Gale et al., 4,867,982 to  
18 Campbell et al., and 5,268,209 to Hunt et al., of which any of the disclosed  
19 systems can be used with the present invention. Two examples of passive  
20 transdermal delivery devices are illustrated in Figures 3 and 4.

21 In Figure 3, passive transdermal delivery device **88**  
22 comprises a reservoir **90** containing the formulation to be delivered  
23 transdermally. Reservoir **90** is preferably in the form of a matrix containing  
24 the formulation dispersed therein. Reservoir **90** is sandwiched between a  
25 backing layer **92**, which is impermeable to the agent, and an optional rate-  
26 controlling membrane **94**. In Figure 3, the reservoir **90** is formed of a  
27 material, such as a polymer, that is sufficiently viscous to maintain its shape.  
28 If a lower viscosity material is used for reservoir **90**, such as an aqueous gel,  
29 backing layer **92** and rate-controlling membrane **94** would be sealed together  
30 about their periphery to prevent leakage. Located below membrane **94** is skin

1 piercing device **2** with connecting medium **65** on a skin facing surface thereof  
2 which extends through the openings (not shown) in device **2** to contact  
3 membrane **94**. The device **88** adheres to a body surface by means of contact  
4 adhesive layer **96** around the periphery of the device **2** and, optionally, by the  
5 anchoring elements of any of the embodiments described previously. In most  
6 instances, the connecting medium **65** will initially contain agent. A strippable  
7 release liner (not shown) is normally provided along the exposed surface of  
8 adhesive layer **96** and is removed prior to application of device **10** to the body  
9 surface.

10 Alternatively, as shown in enlarged Figure 4, transdermal  
11 therapeutic device **98** may be attached to a body surface by means of a  
12 flexible adhesive overlay **100**. Device **98** is comprised of an agent-containing  
13 reservoir **90** which is preferably in the form of a matrix containing the agent  
14 dispersed therein. Connecting medium **65** extends through the openings **8** to  
15 contact the reservoir **90**. Alternatively, the matrix in reservoir **90** can extend  
16 through the openings **8** initially to be in contact with the connecting medium  
17 **65** or the reservoir and connecting medium can be the same. An  
18 impermeable backing layer **102** is provided adjacent one surface of reservoir  
19 **90**. Adhesive overlay **100** maintains the device on the body surface.  
20 Adhesive overlay **100** can be fabricated together with, or provided separately  
21 from, the remaining elements of the device **98**. With certain formulations, the  
22 adhesive overlay **100** may be preferable to the contact adhesive **96** shown in  
23 Figure 3. This is true, for example, where the agent reservoir contains a  
24 material (such as, for example, an oily surfactant) which adversely affects the  
25 adhesive properties of the contact adhesive layer **96**. Impermeable backing  
26 layer **102** is preferably slightly larger than reservoir **90**, and in this manner  
27 prevents the agents in reservoir **90** from adversely interacting with the  
28 adhesive in overlay **100**. Optionally, a rate-controlling membrane (not shown  
29 in Figure 4) similar to membrane **94** in Figure 3 can be provided on the body  
30 surface side of reservoir **90**. A strippable release liner (not shown) is also

1 normally provided with device **98** and is removed just prior to application of  
2 device **98** to the body surface.

3                   The formulation of reservoir **90** may be aqueous or  
4 nonaqueous based. The formulation is designed to deliver the agent at the  
5 necessary fluxes. Aqueous formulations typically comprise water and about 1  
6 to 60 weight percent of a hydrophilic polymer as a gelling agent, such as  
7 hydroxyethylcellulose, hydroxypropylcellulose, hydroxyethylmethacrylate and  
8 polymers used in soft contact lenses. Typical non-aqueous formulations are  
9 comprised of silicone fluid, silicone rubbers, hydrocarbon polymers,  
10 polyisobutylene, rubbers, or mineral oil. Mineral oil-based gels also typically  
11 contain 1 to 2 weight percent of a gelling agent such as colloidal silicon  
12 dioxide.

13                   The reservoir matrix having agent therein should be  
14 compatible with the delivered agent, uptake inhibiting agent (if any) and any  
15 carrier therefore. When using an aqueous-based system, the reservoir matrix  
16 is preferably a hydrophilic polymer (e.g., a hydrogel). When using a non-  
17 aqueous-based system, the reservoir matrix is preferably composed of a  
18 hydrophobic polymer. Suitable polymeric matrices are well known in the  
19 transdermal drug delivery art.

20                   When a constant agent delivery rate is desired, the agent is  
21 present in the matrix or carrier at a concentration in excess of saturation, the  
22 amount of excess being a function of the desired length of the agent delivery  
23 period of the system. The agent may, however, be present at a level below  
24 saturation as long as the polypeptide/histidine formulation and the uptake-  
25 inhibiting agent (if any) are continuously and co-extensively administered to  
26 the same body surface site in an amount and for a period of time sufficient to  
27 reduce or eliminate skin irritation by the agent.

28                   In addition to the agent, the connecting medium may also  
29 contain dyes, pigments, inert fillers, permeation enhancers, excipients  
30 tackifiers, neutral polymers, surfactants, reagents, buffers, plasticizers, and

1 other conventional components of pharmaceutical products or transdermal  
2 devices known in the art.

3                   The amount of agent present in the reservoir and the size of  
4 the reservoir is generally non-limited and is an amount equal to or larger than  
5 the amount of agent that in its released form is effective in bringing about the  
6 desired local and/or systemic physiological and/or pharmacological effects.

7                   The preferred form in which an agent is delivered generally  
8 determines the type of delivery system to be used, and vice versa. That is,  
9 the selection of a passive system which delivers the agent by diffusion or an  
10 electrically powered system which delivers the agent by electrotransport will  
11 be mostly determined by the form of the agent. For example, with passive  
12 delivery systems, it has generally been recognized that the agent is preferably  
13 delivered in either its free base or acid form, rather than in the form of a water  
14 soluble salt when the agent diffuses through the stratum corneum. On the  
15 other hand, with electrotransport delivery devices, it has been recognized that  
16 the agents should generally be soluble in water. It is generally believed that  
17 the pathways for passive and electrotransported transdermal agent delivery  
18 through intact skin are different, with passive delivery occurring through lipid  
19 regions (i.e., hydrophobic regions) of the skin and electrotransport delivery  
20 occurring through hydrophilic pathways or pores such as those associated  
21 with hair follicles and sweat glands. For the case of pierced skin, substantial  
22 passive flux through the created pathways which are aqueous can be  
23 expected. The agent for passive delivery in the case of pierced skin is  
24 generally hydrophilic (e.g., water soluble salt form) and the preferred form of  
25 an agent for electrotransport delivery is also hydrophilic (e.g., water soluble  
26 salt form). For passive delivery, a combination of ionized agent (e.g., water  
27 soluble) and unionized agent (e.g., hydrophilic) can be used.

28                   In one preferred embodiment for passive transdermal  
29 delivery of insulin, the formulation will contain a histidine buffer and an insulin  
30 compound that is zinc-free and devoid of preservatives such as m-cresol or

1 phenol, and either wild-type human insulin or an analog of insulin with a  
2 reduced tendency to self-associate, such as a human Lys<sup>B28</sup>Pro<sup>B29</sup> insulin  
3 analog. Such a formulation maximizes the proportion of the insulin molecules  
4 present as the more rapidly diffusing lower molecular weight species.

5           The polypeptide/histidine formulations may also be  
6 delivered using osmotic and pressure driven systems which deliver agents by  
7 connective flow carried by a solvent. In such systems, the agent preferably  
8 has sufficient solubility in the carrier solvent. It will be appreciated by those  
9 working in the field that the present invention can be used in conjunction with  
10 a wide variety of osmotic and pressure driven systems, as the invention is not  
11 limited to a particular device in this regard. For examples of osmotic and  
12 pressure driven devices, reference may be had to U.S. Patent Nos. 4,340,480  
13 to Eckenhoff, 4,655,766 to Theeuwes et al., 4,753,651 to Eckenhoff,  
14 5,279,544 to Gross et al., 4,655,766 to Theeuwes, 5,242,406 to Gross et al.,  
15 and 4,753,651 to Eckenhoff any of which can be used with the present  
16 invention.

17           While the invention has been described in conjunction with  
18 the preferred specific embodiments thereof, it is to be understood that the  
19 foregoing description as well as the examples which follow are intended to  
20 illustrate and not limit the scope of the invention. Other aspects, advantages  
21 and modifications within the scope of the invention will be apparent to those  
22 skilled in the art to which the invention pertains.

23

### 24 III. Experimental

25

26

#### Materials

27

28 Human insulin (produced by expression in *E. coli*),  $\beta$ -  
29 lactoglobulin, L-histidine (base) and serinamide were purchased from Sigma  
30 (St.Louis, MO). The Sigma insulin preparation contained about 0.4% Zn  
which was equivalent to about 2 zinc atoms per insulin hexamer. Humalog<sup>®</sup>

1 (a Lys<sup>B28</sup>Pro<sup>B29</sup> human insulin analog) as well as Humulin® (human insulin  
2 injection), both of recombinant DNA origin and manufactured by Lilly  
3 (Indianapolis, IN) were purchased from commercial pharmacies. L-histidine  
4 (base) was obtained from J.T. Baker (Phillipsburg, NJ), as well as from Sigma  
5 (St. Louis, MO). Glacial acetic acid was obtained from J.T. Baker  
6 (Phillipsburg, NJ). Hydrochloric acid was purchased from Mallinckrodt (Paris,  
7 KY). Sodium chloride (NaCl) was supplied by Aldrich (St. Louis, MO).  
8 Lysozyme was obtained from Worthington Biochemical Corp. (Freehold NJ).  
9 L-Glycyl-L-histidine dipeptide was synthesized by Bachem Bioscience Inc.  
10 (King of Prussia, PA).

11

12

### Methods

#### Preparation of zinc-free human insulins

14

All human insulins available from commercial sources  
15 contain about 2 bound zinc molecules per insulin hexamer. The zinc bound  
16 to the wild-type human insulin (available from Sigma or as Humulin® R) and  
17 the Lys<sup>B28</sup>Pro<sup>B29</sup> analog (available as Humalog®) can be removed by extensive  
18 dialysis against 10 mM acetic acid at 4°C. In the case of Humulin® R and  
19 Humalog®, the pH of the injectable insulin was first adjusted from neutral pH  
20 to pH 3.5 using glacial acetic and 1N hydrochloric acid prior to dialysis. The  
21 insulin was then freeze-dried after dialysis. Zinc analysis of the freeze-dried  
22 material indicated that residual zinc was less than 0.03 zinc/hexamer.

23

#### Preparation of L-histidine and L-glycyl-L-histidine buffers

25

Milli-Q water (Millipore, Medford, MA) was used for the  
26 preparation of all buffers. Buffers were filtered through 0.22 μm cellulose  
27 acetate membranes prior to use. The pH of a 252 mM L-histidine solution  
28 was about pH 7.62 ± 0.1 at 22°C and the pH of a 1 M L-glycyl-L-histidine  
29 buffer was about pH 7.68 ± 0.1 at 22°C.

30

1 Preparation of serinamide buffer

2 A 100 mM serinamide buffer stock was prepared and the pH  
3 adjusted to  $7.5 \pm 0.1$ .

4  
5 Preparation of insulin in L-histidine and L-glycyl-L-histidine buffers

6 An insulin stock solution was prepared for each experiment  
7 performed in the analytical ultracentrifuge. The concentration of the stock  
8 solution was determined by diluting an aliquot into 6 M guanidine  
9 hydrochloride (Pierce, Rockford, IL) and monitoring its absorbance in a  
10 spectrophotometer (Aviv, model 14DS, Lakewood, NJ). The absorbance of  
11 the sample was corrected for light scattering prior to determining its  
12 concentration using a molar extinction coefficient of  $1.109 \text{ mL mg}^{-1}\text{cm}^{-1}$  at 276  
13 nm). For preparations that contained histidine, the insulin stock solution was  
14 made in either 250 or 330 mM L-histidine. For L-glycyl-L-histidine, the insulin  
15 stock solution was prepared in 260 mM and/or 1 M L-glycyl-L-histidine buffer.  
16 Typically, with wild-type insulin containing about 2 zinc/hexamer, a stock  
17 solution of up to 10 mM (about  $60 \text{ mg mL}^{-1}$ ) was prepared in either L-histidine  
18 or L-glycyl-L-histidine. For preparations without histidine, a stock solution  
19 containing  $7.1 \text{ mg mL}^{-1}$  of 2 zinc/hexamer wild-type insulin was prepared in  
20 mM NaCl, adjusted to pH 7.5 with NaOH. In the case of zinc-free wild-type  
21 and/or Lys<sup>B28</sup>Pro<sup>B29</sup> human insulin analog, a stock solution of up to 17 mM  
22 (about  $100 \text{ mg mL}^{-1}$ ) can be prepared in either 0.1 M NaCl, pH 7.5 and/or 250  
23 mM histidine, 0.1 M NaCl, pH 7.5. The pH of the insulin stock solution was  
24 about  $7.68 \pm 0.1$  in a 1 M glycyl-histidine buffer and  $7.62 \pm 0.1$  in 250 mM  
25 histidine at 22 °C.

26 Prior to the analytical ultracentrifuge run, the insulin stock  
27 solution was diluted with either histidine or glycyl-histidine buffer with or  
28 without the appropriate amount of NaCl such that the concentration of insulin  
29 varied from as low as  $2 \text{ mg mL}^{-1}$  (0.35 mM) to as high as  $40 \text{ mg mL}^{-1}$  (7 mM).  
30 The final concentration of the L-histidine buffer into which the insulin was

1 dissolved varied from 10 mM to 252 mM. For L-glycyl-L-histidine, wild-type  
2 insulin containing 2 zinc/hexamer preparations in 250 and 750 mM buffer  
3 were examined in the ultracentrifuge. In addition, sodium chloride, at a final  
4 concentration of 50 and 100 mM, was added to some of the insulin samples  
5 in L-histidine or L-glycyl-L-histidine buffers.

6

#### 7 Preparation of lysozyme & $\beta$ -lactoglobulin

8 Lysozyme solutions (15 mg mL<sup>-1</sup>) were prepared in 0.15 M  
9 NaCl with 0, 100, or 250 mM L-histidine. The pH of the histidine containing  
10 solutions was  $7.60 \pm 0.1$  at 21°C; the pH of the lysozyme solution without L-  
11 histidine was adjusted with dilute base to be the same. Similarly the pH of  $\beta$ -  
12 lactoglobulin in 0.15 M NaCl was adjusted with dilute base to be the same pH  
13 as that in 250 mM L-histidine, pH  $7.74 \pm 0.1$ .

14

#### 15 Sedimentation equilibrium studies in the analytical ultracentrifuge

16 Sedimentation equilibrium experiments with various insulin  
17 formulations were performed at 32°C using an analytical ultracentrifuge  
18 (model XL-A or XL-I; Beckman, Palo Alto, CA).

19 Data at sedimentation equilibrium were obtained for all the  
20 samples using Rayleigh interference optics and/or scanning UV/Visible optics  
21 at various rotor speeds. For the latter, absorbance scans for insulin samples  
22 were monitored at several wavelengths, e.g. 248, 288, 291 and 295 nm. The  
23 molar extinction coefficient values were estimated from scans obtained at the  
24 start of the run with the monochromator set at the above wavelengths. These  
25 values were used to compute the molar association equilibrium constants of  
26 insulin under various conditions. Each data point in the absorbance scans  
27 was recorded as the average of ten scans with a radial distance increment of  
28 0.002 cm. For the interference optical system, light at 675 nm was used to  
29 obtain sedimentation equilibrium data for insulin as well as lysozyme samples.  
30 The fringe displacement of a 1 mg mL<sup>-1</sup> polypeptide solution in a 1 cm path

1 was taken as 2.77 fringes (McMeekin et al., *Biochem. Biophys. Res. Comm.*  
2 (1962) 7:151-156; Doty and Geiduschek, pp. 393-460, in *The Proteins, 1A*,  
3 edited by Neurath and Bailey, Academic Press, N. Y. (1943); Perlmann and  
4 Longsworth, *J. Amer. Chem. Soc.* (1948) 70: 2719-2724). This value was  
5 used to compute the molar association constants for insulin and lysozyme  
6 samples. The monomer molecular weight of human insulin was taken to be  
7 5796 g mol<sup>-1</sup> with a partial specific volume of 0.727 mL g<sup>-1</sup> calculated from  
8 amino acid composition using Cohn and Edsall values for the residue partial  
9 specific volume. In the case of lysozyme, the molecular weight of the  
10 monomer was taken to be 14,315 g mol<sup>-1</sup> and a value of 0.703 mL g<sup>-1</sup> for the  
11 partial specific volume (Sophianopoulos et al., *J. Biol. Chem.* (1962)  
12 237:1107). For  $\beta$ -lactoglobulin, UV absorbance scans were obtained at 280  
13 nm and the molecular weight of the monomer was taken to be 18,400 g mol<sup>-1</sup>.  
14 The partial volume for the latter is 0.747 mL g<sup>-1</sup> (Kelly and Reithel,  
15 *Biochemistry* (1971) 10:2639-2644) and the extinction coefficient used to  
16 compute molar association constants was 0.97 mL g<sup>-1</sup> cm<sup>-1</sup> (Wetlaufer and  
17 Lovrien, *J. Biol. Chem.* (1964) 243:596). The effective buoyant molecular  
18 weight of all proteins in the presence of L-histidine was computed using the  
19 excluded volume model (Jacobsen, et al., *Biochemistry* (1996) 35:13173-  
20 13179) in which the B<sub>AM</sub> value was taken to be simply the monomer molecular  
21 weight multiply by the partial specific volume. The partial specific volume of  
22 L-histidine and L-glycyl-histidine was taken to be 0.641 mL g<sup>-1</sup> (pp. 370-381,  
23 *Proteins, Amino Acids, and Peptides*, (1943) edited by Cohn and Edsall,  
24 Hafner Publishing, N.Y.).

25                   After centrifugation, the data obtained from the interference  
26 and absorbance scans were analyzed using known methods which included  
27 an algorithm based on equation 9 in Shire, et al., *Biochemistry* (1991)  
28 30:7703-7711. The algorithm used included a modification in which the fitting  
29 parameter was (BM<sub>1</sub>)<sup>1/2</sup> instead of (B)<sup>1/2</sup>. This analysis yields estimates for the  
30 association constants for user-specified model. The model can be that of an

1 ideal monomer (the simplest model) or a monomer existing in chemical  
2 equilibrium with one, two, three or more aggregates of specific sizes. The  
3 most probable model is that which minimizes the sum of squares of the  
4 difference between the experimental absorbance from the theoretical  
5 absorbance, i.e. the model that has the lowest value for the root mean  
6 squared residuals.

7

### 8 Example 1

#### 9 Effect of L-histidine on the 10 solubility limit of insulin

11 To determine the effect of L-histidine on the solubility limit of  
12 2 zinc/hexamer wild-type human insulin, varying concentrations of insulin  
13 were combined with L-histidine. As shown in Figure 1, the use of L-histidine  
14 in the buffer solution increased the maximal insulin concentration of an  
15 insulin-containing buffer solution. Without L-histidine, at pH 7.5, 10 mM NaCl  
16 and at room temperature, the highest concentration of insulin with 2  
17 zinc/hexamer attained was 7.1 mg mL<sup>-1</sup> or 1.2 mM. In the presence of 250  
18 mM histidine at its pI, insulin solutions with a concentration as high as 16.5  
19 mM were obtained, representing a 15-fold increase in concentration.

20

### 21 Example 2

#### 22 Effect of L-histidine and L-glycyl-histidine at pI 23 on insulin self-association in the absence of NaCl

24 To determine the effect of L-histidine and L-glycyl-histidine  
25 at their pIs on self-association in the absence of NaCl, sedimentation  
26 equilibrium studies were performed as described above. As shown in Table I,  
27 increased L-histidine concentration resulted in a decrease of the  
28 hexamerization equilibrium constant. At pH 7.5, in the absence of any  
29 histidine, the sedimentation equilibrium data (collected at 32°C and a rotor  
30 speed from 18k to 48k) could be fitted to a dimer hexamer association model

1 with a  $\ln K_{2,6}$  value of 52.6. The non-ideality coefficient, B, takes into account  
2 non-ideality effect arising due to the very low ionic strength of the buffer.  
3 Assuming that a single molecular weight species was present, data analysis  
4 using the simplest model gave a  $M_{\text{avg}}/M_1$  value of 5.5, suggesting that the  
5 average size of the insulin aggregates in the absence of any histidine, was  
6 slightly less than a hexamer. The observation that 3 insulin dimers assemble  
7 to form a hexamer in the presence of zinc at neutral pH is consistent with  
8 published data (Brange, *Galenics of insulin*, (1987) Springer Verlag). The  
9 sedimentation equilibrium data collected in the presence of 20 to 252 mM  
10 histidine at pH  $7.6 \pm 0.1$  at multiple rotor speeds were fitted to a dimer  
11 hexamer association model. A decrease in the hexamerization equilibrium  
12 constant was observed as the concentration of histidine was increased from  
13 20 to 252 mM. The effect of histidine was observed with insulin at insulin  
14 concentrations in the centrifuge cell ranging from as low as 0.01 mM (0.1 mg  
15  $\text{mL}^{-1}$ ) to as high as 13 mM (75 mg  $\text{mL}^{-1}$ ). Despite the fact that histidine  
16 dramatically increased the solubility of insulin (solubility limit was 16.5 mM in  
17 250 mM his, pH  $7.5 \pm 0.1$ ), not all the insulin aggregated under these  
18 conditions were dimers and hexamers. Aggregates of multiple hexamers  
19 were also found at the highest insulin loading concentration (6 mM) examined  
20 in the ultracentrifuge. Only 80% of the insulin initially loaded in the cell  
21 remained in solution when the sample reached equilibrium at a rotor speed of  
22 20k rpm. The remaining 20% of the insulin pelleted to the cell bottom as  
23 large insoluble aggregates. A rough calculation suggested that the  
24 aggregates had an average molecular weight in excess of 100,000,  
25 equivalent to about 3 insulin hexamers.

26 Glycyl-histidine was one of the histidine analogs that was  
27 examined for its effect on insulin self-association. At 250 mM, glycyl-histidine  
28 also reduced the tendency of insulin to form hexamers but not as effectively  
29 as histidine. Analysis of sedimentation equilibrium acquired using  
30 interference optics at a rotor speed of 50K using the single species model

1 indicated that the average molecular weight of insulin was that of a tetramer  
2 in glycyl-histidine (Table I). As a comparison, at 252 mM histidine (the  
3 highest concentration examined in the ultracentrifuge), the average molecular  
4 weight of insulin was that of a dimer. Substitution of histidine with another  
5 buffer, serinamide, also adjusted to pH  $7.5 \pm 0.1$ , failed to reduce the ability of  
6 wild-type insulin to self-associate at neutral pH.

1 Table I Effect of various buffers on the self-association of wild- type human insulin (with 2 zinc-  
 2 bound per hexamer) in the absence of sodium chloride at pH 7.5 ± 0.1 and 32°C as analyzed  
 3 using a dimer-hexamer association model

| 4                        | 5    | 6             | 7             | 8      | 9      | 10 |
|--------------------------|------|---------------|---------------|--------|--------|----|
| Buffer                   | I.S. | $M_{avg}/M_1$ | $\ln K_{2-6}$ | r.m.s. | B      |    |
| no additive <sup>1</sup> | 2.8  | 5.5           | 52.6          | 0.006  | 1.8E-6 |    |
| serinamide <sup>1</sup>  | 22   | 5.2           | 25.0          | 0.0080 | 1.7E-6 |    |
| 38 mM                    |      |               |               |        |        |    |
| histidine <sup>1</sup>   | 3.3  | 4.2           | 20.7          | 0.0080 | 5.5E-6 |    |
| 20 mM                    |      |               |               |        |        |    |
| histidine <sup>2</sup>   | 5.6  | 3.3           | 18.3          | 0.0144 | 7.7E-6 |    |
| 113 mM                   |      |               |               |        |        |    |
| histidine <sup>3</sup>   | 6.3  | 2.3           | 14.2          | 0.006  | ~0     |    |
| 240 mM                   |      |               |               |        |        |    |
| histidine <sup>4</sup>   | 6.3  | 2.6           | 14.4          | 0.0235 | 2.0E-6 |    |
| 252 mM                   |      |               |               |        |        |    |
| gly-his <sup>5</sup>     | 27.5 | 4.3           | 18.2          | 0.0464 | 7.9E-7 |    |
| 250 mM                   |      |               |               |        |        |    |

29 I.S. is the ionic strength of the buffer in mM

30 B (g<sup>2</sup>L mol) is the non-ideality coefficient, calculated based on an insulin dimer

31 r.m.s. is the root mean square residual between experimental and theoretical data

32  $M_{avg}/M_1$  is the average molecular weight of the sedimentating species divided by the molecular  
 33 weight of the insulin monomer for a single, species non ideal model

34  $\ln K_{2-6}$  is the natural logarithm of the association constant for the formation of a hexamer from 3  
 35 dimers

36

- 1 <sup>1</sup> obtained from uv absorbance scans monitored at 291 nm of a 0.34 mM insulin sample at
- 2 18k, 24k, 28k, 34k and 48k rotor speed
- 3 <sup>2</sup> obtained from uv absorbance scans monitored at 291 nm of a 0.69 mM insulin sample at
- 4 15k, 20k, 25k and 30k rotor speed
- 5 <sup>3</sup> obtained from uv absorbance scans monitored at 291 nm of a 0.35 mM insulin sample at
- 6 24k, 28k, 34k and 48k rotor speed
- 7 <sup>4</sup> obtained from interference optics of a 6 mM insulin sample at 50k rotor speed
- 8 <sup>5</sup> obtained from interference optics of insulin sample at 3 and 6 mM at 50k rotor speed
- 9

### Example 3

Effect of L-histidine and L-glycyl-histidine  
at pI on the self-association of wild-type  
human insulin with two zinc bound per hexamer  
in the presence of NaCl

To determine the effect of L-histidine and L-glycyl-histidine at their pIs on insulin self-association in the presence of NaCl, experiments were conducted as described above. Upon increasing the ionic strength of the pH 7.5 samples to about 100 mM with sodium chloride, wild-type human insulin existed mostly as hexamers in the absence of histidine buffer. As shown in Table II, as the concentration of histidine in the insulin samples increased from 50 to 226 mM, there was a modest decrease in the hexamerization equilibrium constant. The effect was not as dramatic as that seen in the absence of salt (see Table I). At 226 mM, the highest histidine concentration examined at an ionic strength of 100 mM, the  $M_{avg}/M_1$  value calculated based on the assumption of a single insulin species, was about 6. In contrast, in the absence of NaCl, insulin was mainly found as dimers in 252 mM histidine, pH  $7.6 \pm 0.1$ . In addition, in the presence of 226 mM histidine and 100 mM NaCl, irrespective of the initial loading concentration of insulin, the final concentration of insulin which sedimented with an average size equal or less than that of a dodecamer was about 2 mM. The rest of the insulin sample pelleted to the bottom of the cell at a rotor speed of 20k. Thus, the percent of insulin that formed very large aggregates was considerably higher in histidine buffer containing 100 mM NaCl than without NaCl. In the latter case, the insulin concentration range which resulted in pelleting of large aggregates was about 4.8 mM.

These results show that the effect of histidine on the self-association of insulin is dependent on the ionic milieu of the medium. Preliminary data suggested that the Gibb\*s free energy of formation of an insulin dodecamer from 2 hexamers increases as a function of the square

1 root of the ionic strength of the buffer.

2                                   In the case of L-glycyl-L-histidine, addition of 50 mM  
3 NaCl to the wild-type human insulin sample (raising the total ionic strength to  
4 77.5 mM) gave a hexamerization equilibrium constant close to that observed  
5 for insulin in 226 mM histidine and 100 mM NaCl (Table II). Histidine is a  
6 zwitterion at its pI, and its effect on insulin seems to be specific. For example,  
7 as shown in Table II, the use of taurine, another zwitterion at pH  $7.5 \pm 0.1$ , at  
8 an ionic strength of about 100 mM, failed to reduce the hexamerization  
9 equilibrium constant of insulin.

10

11

12

13

14

15

16

17

18

1 Table II Effect of L-histidine and L-glycyl- L-histidine on the self-association of  
 2 2 zinc/hexamer wild-type human insulin in the presence of 50 and 100 mM  
 3 sodium chloride at pH 7.5 ± 0.1 and 32°C as analyzed using a dimer-  
 4 hexamer association model

| <b>50 mM NaCl</b>           |             |                                      |                          |               |  |
|-----------------------------|-------------|--------------------------------------|--------------------------|---------------|--|
| <u>Buffer</u>               | <u>I.S.</u> | <u>M<sub>avg</sub>/M<sub>1</sub></u> | <u>lnK<sub>2-6</sub></u> | <u>r.m.s.</u> |  |
| 8 histidine <sup>1a</sup>   | 56          | 4.8                                  | 14.3                     | 0.009         |  |
| 9 240 mM                    |             |                                      |                          |               |  |
| 10                          |             |                                      |                          |               |  |
| 11 gly-his <sup>2</sup>     | 77.5        | 4.4                                  | 16.7                     | 0.087         |  |
| 12 247 mM                   |             |                                      |                          |               |  |
| 13                          |             |                                      |                          |               |  |
| <b>100 mM NaCl</b>          |             |                                      |                          |               |  |
| <u>Buffer</u>               | <u>I.S.</u> | <u>M<sub>avg</sub>/M<sub>1</sub></u> | <u>lnK<sub>2-6</sub></u> | <u>r.m.s.</u> |  |
| 17 no additive <sup>3</sup> | 103         | 5.8                                  | 23.9                     | 0.007         |  |
| 18                          |             |                                      |                          |               |  |
| 19 taurine <sup>4</sup>     | 103         | 5.8                                  | 24.6                     | 0.010         |  |
| 20 113 mM                   |             |                                      |                          |               |  |
| 21                          |             |                                      |                          |               |  |
| 22 histidine <sup>4</sup>   | 104         | 4.8                                  | 21.1                     | 0.009         |  |
| 23 50 mM                    |             |                                      |                          |               |  |
| 24                          |             |                                      |                          |               |  |
| 25 histidine <sup>5</sup>   | 106         | 4.5                                  | 20.7                     | 0.012         |  |
| 26 113 mM                   |             |                                      |                          |               |  |
| 27                          |             |                                      |                          |               |  |

|   |                         |     |     |      |       |
|---|-------------------------|-----|-----|------|-------|
| 1 | histidine <sup>6</sup>  | 105 | 4.4 | 19.6 | 0.007 |
| 2 | 206 mM                  |     |     |      |       |
| 3 | histidine <sup>1b</sup> | 106 | 6.4 | 15.6 | 0.009 |
| 4 | 226 mM                  |     |     |      |       |

5

6

7 <sup>1a</sup> obtained from absorbance scans monitored at 295 nm of insulin samples at  
8 3 and 6 mM at 20k and 30k rotor speed

9 <sup>1b</sup> obtained from absorbance scans monitored at 295 nm of insulin samples at  
10 3 and 6 mM at 20k and 30k rotor speed with dimer-hexamer-isodesmic  
11 hexamer ideal model with an  $\ln K_{\text{isodesmic}}$  constant of 4.24

12 <sup>2</sup> obtained from interference optics of insulin samples at 3 and 6 mM at a 50k  
13 rotor speed

14 <sup>3</sup> obtained from uv absorbance scans monitored at 291 nm of an insulin  
15 sample at 0.35 mM at 18k, 24k, 34k and 48k rotor speed

16 <sup>4</sup> obtained from uv absorbance scans monitored at 288 nm of a 0.7 mM  
17 insulin sample at 15k, 20k, 25k, 30k and 40k rotor speed

18 <sup>5</sup> obtained from uv absorbance scans at 288 (0.35 mM) and 248 nm (0.7 mM)  
19 insulin sample at 15k, 20k, 25k, 30k and 40k rotor speed

20 <sup>6</sup> obtained from uv absorbance scans at 248 nm of a 0.35 mM insulin sample  
21 at 15k, 20k, 25k and 30k rotor speed

22

23  $\ln K_{\text{iso}}$  is the natural logarithm of the association constant for the formation of  
24 isodesmic hexamers

#### Example 4

Effect of L-histidine at pI on self-  
association of wild-type Zn-free insulin  
and a Zn-free, LysPro insulin analog

Sedimentation equilibrium studies were conducted in a XL-I analytical ultracentrifuge at 32°C with native, wild-type human insulin (Zn-free, from Sigma and Humulin® R) as well as a Zn-free Lys<sup>B28</sup>Pro<sup>B29</sup> insulin analog (purified from Humalog®, Lilly) as a function of increasing concentration of histidine, pH 7.5, as described above. Interference data were acquired over multiple rotor speeds, pooled and globally analyzed using non linear regression fitted to several models. In the presence of 100 mM NaCl, pH 7.5, the data from wild-type and Lys<sup>B28</sup>Pro<sup>B29</sup> human insulin, both free of zinc, can be fitted to a model containing monomer, dimer, hexamer and isodesmic hexamers.

As shown in Table III, for the Zn-free LysPro analog, the value of  $\ln K_{12}$  did not change significantly with the concentration of histidine but  $\ln K_{6iso}$  showed a significant decrease with increasing histidine concentration. The results suggested that histidine had an effect on the self-association properties of the LysPro insulin analog. A succinct method of expressing the degree of aggregation of a protein is to compute an average molecular weight from the association equilibrium constants. Several such averages are well described in the literature (see, e.g., "Analytical Ultracentrifugation in Biochemistry and Polymer Science," Ed. S.E. Hardin, A.J. Rowe, and J.C. Horton, Royal Society of Chemistry, Cambridge, 1992). One,  $M_n$ , or the number average molecular weight is defined as  $c_{total}/\sum(c_i/M_i)$ , where  $c_i$  is the weight concentration of the  $i^{th}$  species with molecular weight  $M_i$ . A second type of average,  $M_w$ , called the weight average molecular weight, is defined as  $\sum c_i M_i / c_{total}$ . Yet higher molecular weight averages such as  $M_z$  may be defined, where  $M_z = \sum c_i M_i^2 / \sum c_i M_i$ . Figure 5 shows the concentration dependence of these three averages for the LysPro insulin

1 analog in the presence of 240 mM histidine (calculated from  $\ln K_{12}$ ,  $\ln K_{26}$  and  
2  $\ln K_{6iso}$  values for 240 mM histidine in Table III) while Figure 6 shows a similar  
3 plot for the situation in the absence of histidine (calculated from  $\ln K$  values for  
4 0 mM histidine in Table III). Figure 7 shows the similar plot for zinc-free wild-  
5 type insulin in the presence of 240 mM histidine (calculated from  $\ln K_{12}$ ,  $\ln K_{26}$   
6 and  $\ln K_{6iso}$  values for 240 mM histidine in Table IV) while Figure 8 shows a  
7 comparable plot in the absence of histidine (calculated from  $\ln K$  values for 0  
8 mM histidine in Table IV).

9                                   It is evident from these plots that the presence of  
10 histidine substantially reduces the average molecular weight of the insulin,  
11 and that this effect is more pronounced for the LysPro analog.

Table III

Lys<sup>628</sup>Pro<sup>629</sup> human insulin analog (Zn-free) in 100 mM NaCl, pH 7.5, 32°C

for each condition five rotor speeds (12, 18, 24, 34, 50k) gave interference data that were pooled and globally analyzed.

| [His] | ln(K <sub>12</sub> ) | ln(K <sub>26</sub> ) | ln(K <sub>650</sub> ) | rms   | [insulin] range               |
|-------|----------------------|----------------------|-----------------------|-------|-------------------------------|
| 0     | 6.50                 | 14.1                 | 6.07                  | 0.049 | 1x10 <sup>-5</sup> to 9.0 mM  |
| 10    | 6.7                  | 14.0                 | 6.02                  | .112  | 1x10 <sup>-5</sup> to 7.3 mM  |
| 20    | 5.88                 | 14.2                 | 5.85                  | .205  | 1x10 <sup>-5</sup> to 10.0 mM |
| 40    | 6.0                  | 14.1                 | 5.66                  | .177  | 1x10 <sup>-5</sup> to 10.0 mM |
| 80    | 6.74                 | 13.6                 | 5.86                  | .171  | 1x10 <sup>-5</sup> to 11.0 mM |
| 160   | 6.59                 | 13.5                 | 5.62                  | .171  | 1x10 <sup>-5</sup> to 10.6 mM |
| 240   | 6.71                 | 13.2                 | 5.00                  | .151  | 1x10 <sup>-5</sup> to 11.2 mM |

ln(K<sub>650</sub>) = 6.01 - 0.0037[histidine], p = 0.004

ln(K<sub>12</sub>) is the natural logarithm of the association constant for the formation of a dimer from 2 insulin monomers

ln(K<sub>26</sub>) is the natural logarithm of the association constant for the formation of an insulin hexamer from 3 dimers

ln(K<sub>650</sub>) is the natural logarithm of the association constant for the formation of stacked hexamers

The loading concentration of insulin was 4 mM for each condition. During centrifugation, insulin redistributes throughout the centrifuge cell.

The [insulin] range reported in the table reflects the range of [insulin] observed under various rotor speeds for each condition.

Table IV

Wild-type human insulin (Zn-free) in 100 mM NaCl, pH 7.5, 32°C

for each condition five rotor speeds (12, 18, 24, 34, 50k) gave interference data that were pooled and globally analyzed.

| [His] | ln(K <sub>12</sub> ) | ln(K <sub>26</sub> ) | ln(K <sub>60</sub> ) | rms   | [insulin] range             |
|-------|----------------------|----------------------|----------------------|-------|-----------------------------|
| 0     | 8.8                  | 18.7                 | 7.24                 | 0.093 | 1x10 <sup>5</sup> - 4.7 mM  |
| 10    | 10.1                 | 17.9                 | 7.17                 | 0.069 | 1x10 <sup>5</sup> - 4.5 mM  |
| 20    | 7.9                  | 19.1                 | 7.00                 | 0.102 | 1x10 <sup>5</sup> - 4.8 mM  |
| 40    | 8.8                  | 18.8                 | 7.00                 | 0.085 | 1x10 <sup>5</sup> - 4.6 mM  |
| 80    | 8.5                  | 18.8                 | 6.69                 | 0.065 | 1x10 <sup>5</sup> - 4.2 mM  |
| 160   | 10.0                 | 18.0                 | 7.05                 | 0.021 | 1x10 <sup>5</sup> - 2.1 mM  |
| 224   | 9.9                  | 16.6                 | 6.65                 | 0.125 | 1.5x10 <sup>5</sup> - 15 mM |
| 240   | 8.5                  | 18.5                 | 6.58                 | 0.073 | 1x10 <sup>5</sup> - 4.2 mM  |

ln(K<sub>12</sub>) = 9.06 (mean) (s.e.m. = 0.273) (no significant dependence on [histidine])

ln(K<sub>60</sub>) = 7.116 - 0.002[histidine], p = 0.02

The insulin loading concentration was 2 mM for each condition with the exception of 224 mM histidine. In the latter, the data reported were obtained by combining data from 3 insulin loading concentrations of 1, 3 and 6 mM.

### Example 5

#### Effect of L-histidine at its pI on the self-association of other proteins

The effect of L-histidine on self-association of lysozyme and  $\beta$ -lactoglobulin was also studied, using the methods described above. Lysozyme and  $\beta$ -lactoglobulin are well-studied proteins which predominately exist in a monomer-dimer equilibrium at alkaline pH (Kim et al., *Chemical Reviews* (1977) 77:659-690). Lysozyme sedimentation equilibrium data at alkaline pH are better modeled by a monomer-dimer-tetramer system than by a more simple monomer-dimer system (Holladay, Ph.D. Dissertation (1973) Emory University). The self-association behavior of lysozyme without L-histidine at 4°C was assessed by globally analyzing interference fringe data from 14k, 18k, and 30k rpm. The results are given in Table V.

The expected noise in fringe measurement from the Beckman XL-I system is about 0.02 to 0.04 fringes. The 4°C data are best described by an ideal monomer-dimer-tetramer (1-2-4) system. Note that any model which contains aggregates above the dimer size yields essentially identical estimates for the  $\ln(K_{12})$ . Since these results (presented below) on the effect of L-histidine on lysozyme dimerization do not tend to be model-dependent, modeling was done with an ideal 1-2-4 system. Inclusion of a second virial coefficient failed to significantly lower the r.m.s. residual. Isodesmic type I has all aggregates present with identical association constants. Type II has only even aggregates present. Type III has a dimerization constant different from subsequent association steps which are presumed to be isodesmic. Type IV has only even aggregates presumed to be present with a dimerization constant different from subsequent association steps which are presumed to be isodesmic. The equations for the isodesmic models are known in the art, and have been described (Tang et al., *Biophys. Chem.* (1977) 7:121-139). Note that for the isodesmic model IV that the  $\ln(K_{14})$  is 17.9, close to that estimated from the 1-2-4 model. The predicted

1 amounts of aggregates beyond tetramer are quite small for all the isodesmic  
2 models.

3                                   The effect of L-histidine on lysozyme dimerization is  
4 given in Table VI. The results in Table VI were generated using an ideal 1-2-  
5 4 model (monomer-dimer-tetramer) and global analysis of two rotor speeds  
6 differing by 4k rpm. The effect of L-histidine on  $\beta$ -lactoglobulin dimerization at  
7 three temperatures is given in Table VII. For both proteins, there appear to  
8 be modest decreases in the dimerization equilibrium constant with increasing  
9 temperature. For this analysis, it was implicitly assumed that the effective  
10 buoyant molecular weight of any aggregate in the presence of L-histidine is  
11 an integer multiple of the effective buoyant molecular weight of the monomer.  
12 This implies that the  $B_{AM}$  term of any aggregate is an integer multiple of the  
13  $B_{AM}$  term for the monomer. Since in reality the overall shape of an aggregate  
14 is likely to be somewhat different than that of the monomer, it is possible that  
15 the modest decreases in the dimerization constants for lysozyme and  $\beta$ -  
16 lactoglobulin may reflect the failure of the assumption that the buoyant  
17 molecular weight of the aggregate is an integer multiple of that of the  
18 monomer. However it must be noted that the returned value of  $\ln(K_{12})$  does  
19 not tend to be sensitive to changes of a few percent in the monomer buoyant  
20 molecular weight.

1 Table V Effect of the choice of self-association model on the  $\ln(K_{12})$  of lysozyme in  
 2 150 mM NaCl, pH 7.6, 4°C, from a global analysis of interference data obtained at  
 3 14k, 18k and 30k rotor speeds

| 4                  | 5             | 6                            | 7               | 8 |
|--------------------|---------------|------------------------------|-----------------|---|
| model              | $\ln(K_{12})$ | $\ln(K_{\text{additional}})$ | r.m.s. residual |   |
| 1-2                | 6.728         | n.a.                         | 0.114           |   |
| 1-2-4              | 5.431         | 17.9 (1-4)                   | 0.036           |   |
| non ideal 1-2-4    | 5.436         | 18.0                         | 0.036           |   |
| isodesmic Type I   | 5.552         | n.a.                         | 0.048           |   |
| isodesmic Type II  | 5.582         | n.a.                         | 0.054           |   |
| isodesmic Type III | 5.247         | 5.716                        | 0.037           |   |
| isodesmic Type IV  | 5.577         | 5.966                        | 0.041           |   |

23 1-2 denotes model in which monomer exists in equilibrium with dimer

24 1-2-4 denotes model in which monomer exists in equilibrium with dimer and  
 25 tetramer

26  $\ln K_{1-2}$  is the equilibrium constant for formation of a dimer from 2 monomers

27  $\ln K_{1-4}$  is the equilibrium constant for the formation of a tetramer from 4  
 28 monomers

1 Table VI Effect of L-histidine on self-association of lysozyme at pH 7.6, 150  
 2 mM NaCl at multiple rotor speeds using 3 mm centerpiece

| 3           | 4      | 5                         | 6                          | 7  | 8  |
|-------------|--------|---------------------------|----------------------------|----|----|
| 9           | 10     | 11                        | 12                         | 13 | 14 |
| 15          | 16     | 17                        | 18                         | 19 | 20 |
| 21          | 22     | 23                        | 24                         | 25 | 26 |
| Buffer      |        | <u>14k &amp; 18k, 4°C</u> | <u>16k &amp; 20k, 20°C</u> |    |    |
| no additive | 1-2    | 5.64 (0.06) <sup>2</sup>  | 5.15 (0.05)                |    |    |
|             | 1-4    | 17.97 (0.03)              | 16.10 (0.06)               |    |    |
|             | r.m.s. | 0.039                     | 0.043                      |    |    |
| 100 mM his  | 1-2    | 4.85 (0.04)               | 4.32 (0.05)                |    |    |
|             | 1-4    | 17.08 (0.01)              | 15.84 (0.02)               |    |    |
|             | r.m.s. | 0.032                     | 0.040                      |    |    |
| 250 mM his  | 1-2    | 4.13 (0.05)               | 3.48 (0.05)                |    |    |
|             | 1-4    | 16.24 (0.01)              | 15.32 (0.01)               |    |    |
|             | r.m.s. | 0.032                     | 0.031                      |    |    |

19 <sup>1</sup> obtained from fitting interference data globally to a model containing  
 20 monomer-dimer-tetramer existing in equilibrium. The  $\ln K_{1,2}$  and  $\ln K_{1,4}$  are the  
 21 equilibrium constants for the formation of a dimer and tetramer, respectively,  
 22 from a monomer.

23  
 24 <sup>2</sup> values in parentheses are bootstrap standard error of  $\ln K$

25

1     Table VII Effect of L-histidine on the self-association of  $\beta$  lactoglobulin at pH  
 2     7.6, 150 mM NaCl at multiple rotor speeds using a 3 mm centerpiece

|               | 4°C                  | 20°C                 | 32°C                 |
|---------------|----------------------|----------------------|----------------------|
|               | lnK <sup>1</sup>     | lnK <sup>1</sup>     | lnK <sup>1</sup>     |
| <u>Buffer</u> | <u>14k &amp; 18K</u> | <u>16k &amp; 20K</u> | <u>22k &amp; 26K</u> |
| no additive   | 11.34(0.12)          | 10.26(0.12)          | 9.28(0.03)           |
|               | [0.008]              | [0.010]              | [0.008]              |
| 250 mM his    | 9.52(0.06)           | 8.48(0.02)           | 8.03(0.02)           |
|               | [0.005]              | [0.009]              | [0.005]              |

15     <sup>1</sup> obtained from fitting absorbance data globally to an ideal monomer-dimer  
 16     model with floating baseline offset. Bootstrap standard errors of lnK values  
 17     are given in parentheses. Figures in square parentheses denotes root mean  
 18     squared residuals.

1                   Based on the above experiments, it is evident that histidine  
2 and histidine analogs are able to decrease self-association of insulin and  
3 insulin analogs, with and without zinc. In the case of wild-type insulin,  
4 containing 2 zinc molecules/hexamer, over the concentration range  
5 examined, the sedimentation equilibrium data at pH 7.5 can be fitted to a non-  
6 ideal dimer-hexamer model in the absence of NaCl or to an ideal dimer-  
7 hexamer model (when the loading insulin concentration is below 1 mM) in the  
8 presence of 100 mM NaCl. Moreover, there is a striking effect of histidine  
9 concentration on the  $\ln K_{26}$  value of native human 2 zinc/hexamer insulin  
10 whether NaCl is present or not. In the absence of zinc, the effect of histidine  
11 on the LysPro analog is more pronounced than the wild-type insulin. Histidine  
12 is also able to decrease self-association of other totally unrelated proteins,  
13 such as lysozyme and  $\beta$ -lactoglobulin.

14                   Thus, methods for decreasing self-association and  
15 increasing solubility of polypeptide agents are disclosed. Although preferred  
16 embodiments of the subject invention have been described in some detail, it  
17 is understood that obvious variations can be made without departing from the  
18 spirit and the scope of the invention as defined by the appended claims.

1 We claim:

2

3

4 1. A method of decreasing oligomer formation of a  
5 polypeptide, said method comprising combining said polypeptide with an  
6 amount of a histidine compound sufficient to decrease the tendency of said  
7 polypeptide to self-associate.

7

8

9 2. The method of claim 1, wherein the histidine compound

10

11

12 3. The method of claim 1, wherein the histidine compound

13

14

15 4. The method of any of claims 1-3, wherein the

16

17

18 5. The method of claim 4, wherein the insulin compound is

19

20

21 6. The method of claim 5, wherein the insulin compound is

22

23

24 7. The method of claim 6, wherein the insulin compound is

25

26

27 8. The method of claim 4, wherein insulin hexamer

28

29

30 9. The method of claim 4, wherein the concentration of the

30

histidine compound is at least about 10 mmolar.

1

2

10. The method of claim 4, wherein the pH of the composition is about pH 7 to about pH 8.

4

5

6

7

8

9

11. Use of a polypeptide and a histidine compound in the manufacture of a composition useful for delivering a polypeptide agent through a body surface by electrotransport, wherein said histidine compound is present in said composition in an amount sufficient to decrease the tendency of said polypeptide to self-associate.

10

11

12

13

14

15

16

17

18

19

20

21

22

23

24

25

26

27

28

29

30

12. The use of claim 11, wherein the histidine compound is L-histidine.

13. The use of claim 11, wherein the histidine compound is L-glycyl-histidine.

14. The use of any of claims 11-13, wherein the polypeptide is an insulin compound.

15. The use of claim 14, wherein the insulin compound is a human insulin compound.

16. The use of claim 15, wherein the insulin compound is a zinc-free human insulin compound.

17. The use of claim 15, wherein the insulin compound is a human Lys<sup>B28</sup>Pro<sup>B29</sup> insulin analog.

18. The use of claim 14, wherein insulin hexamer formation is decreased.

1

2                   19. The use of claim 14, wherein the concentration of the  
3 histidine compound is about 10 mmolar to about 250 mmolar.

4

5                   20. The use of claim 14, wherein the pH of the composition  
6 is about pH 7 to about pH 8.

7

8                   21. The use of claim 20, wherein the molar ratio of the  
9 insulin compound to the histidine compound is about 1:10 to about 1:1000.

10

11                   22. Use of a human insulin compound and a histidine  
12 compound in the manufacture of a composition useful for delivering a  
13 polypeptide agent through a body surface by passive transdermal delivery,  
14 wherein said histidine compound is present in said composition in an amount  
15 sufficient to decrease the tendency of said polypeptide to self-associate.

16

17                   23. The use of claim 22, wherein the histidine compound is  
18 L-histidine.

19

20                   24. The use of claim 22, wherein the histidine compound is  
21 L-glycyl-histidine.

22

23                   25. The use of claim 22, wherein the insulin compound is a  
24 zinc-free human insulin compound.

25

26                   26. The use of claim 22, wherein the insulin compound is a  
27 human Lys<sup>B28</sup>Pro<sup>B29</sup> insulin analog.

28

29                   27. The use of claim 22, wherein the concentration of the  
30 histidine compound is about 10 mmolar to about 250 mmolar.

1

2

3

28. The use of claim 22, wherein the pH of the composition  
is about pH 7 to about pH 8.

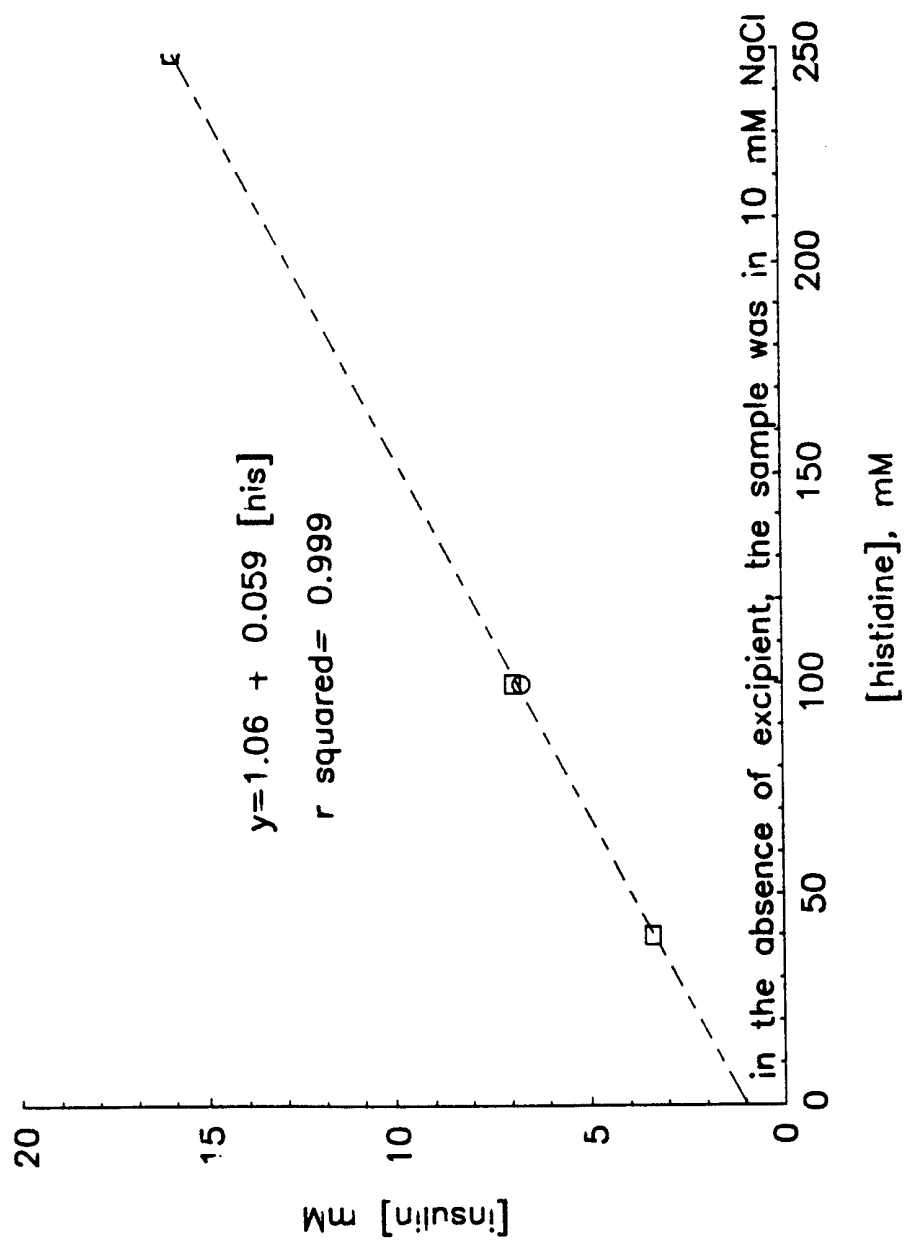
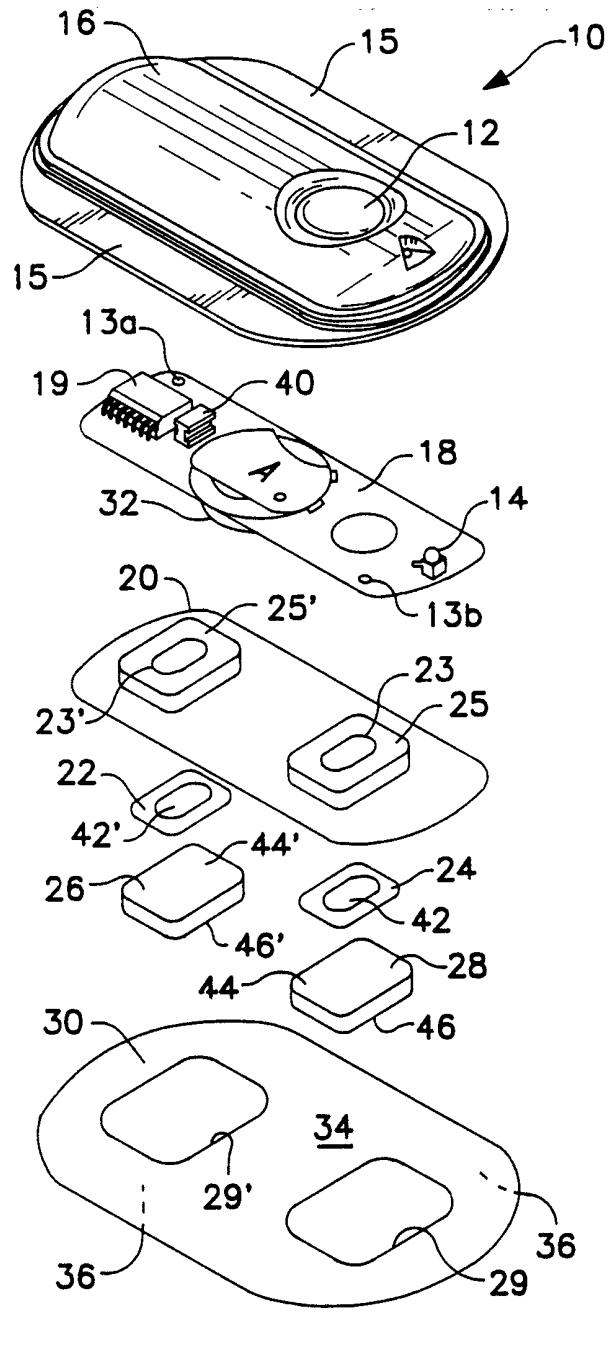

FIG. 1

FIG. 2



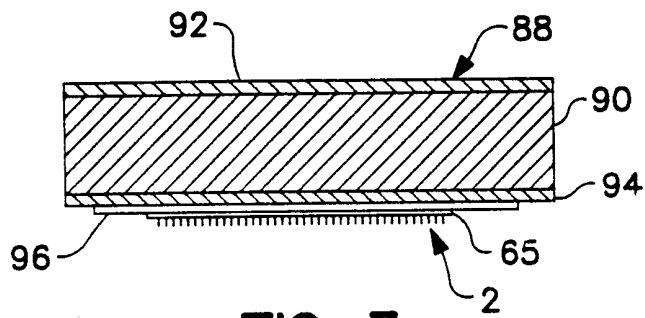

FIG. 3

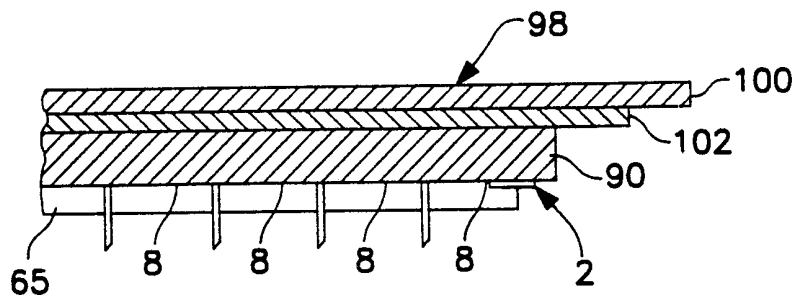

FIG. 4

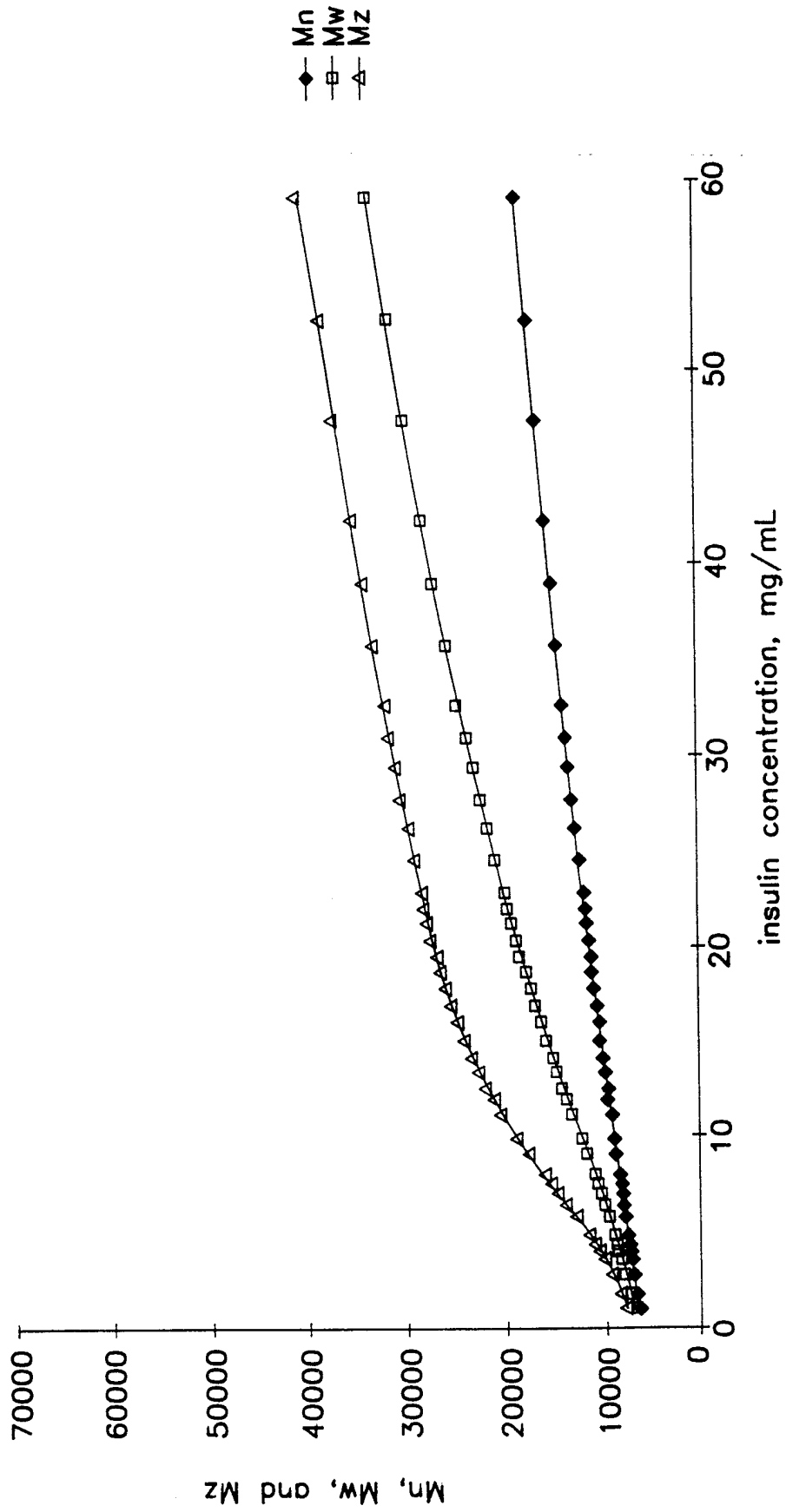

FIG. 5

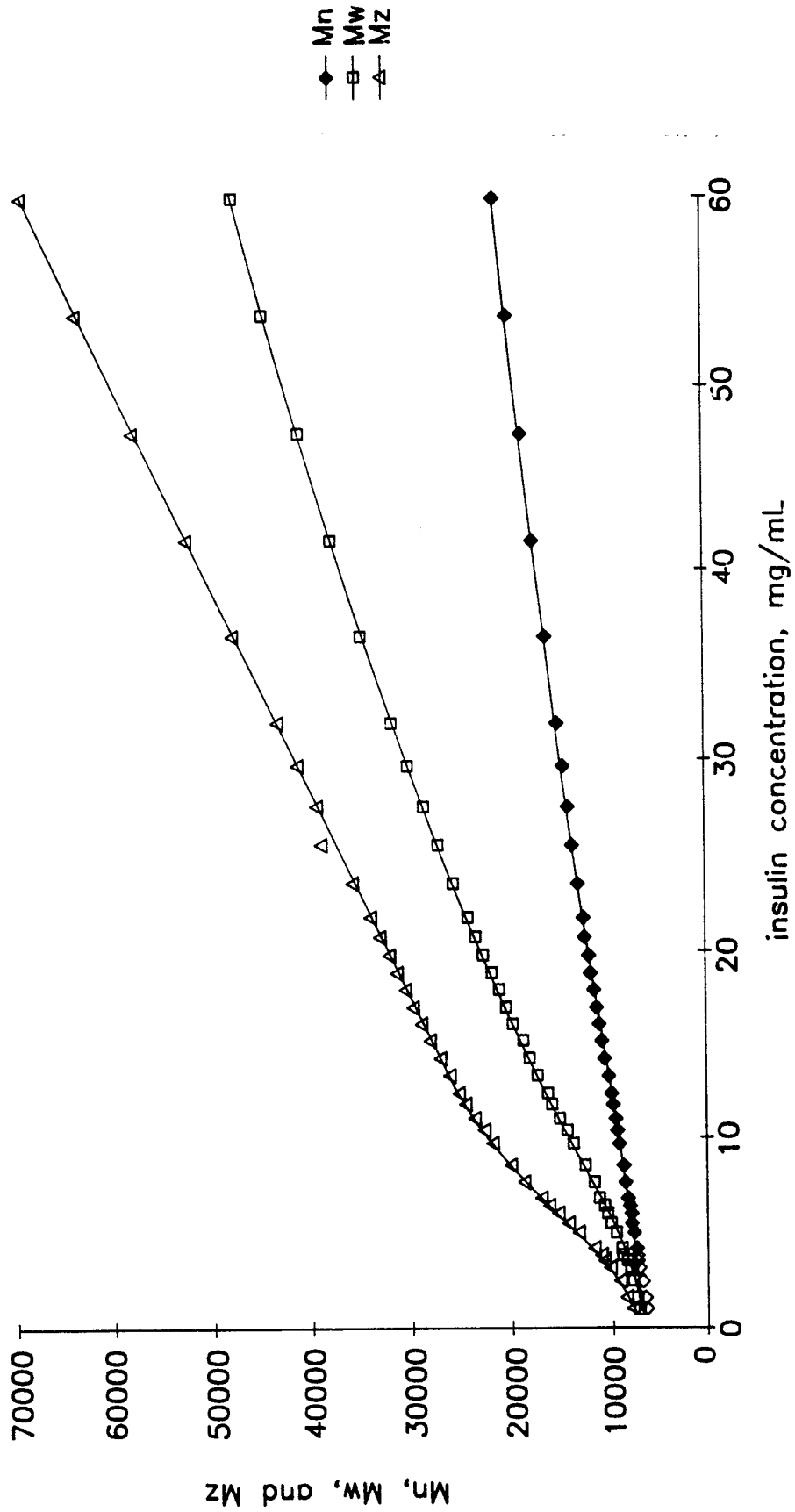

FIG. 6

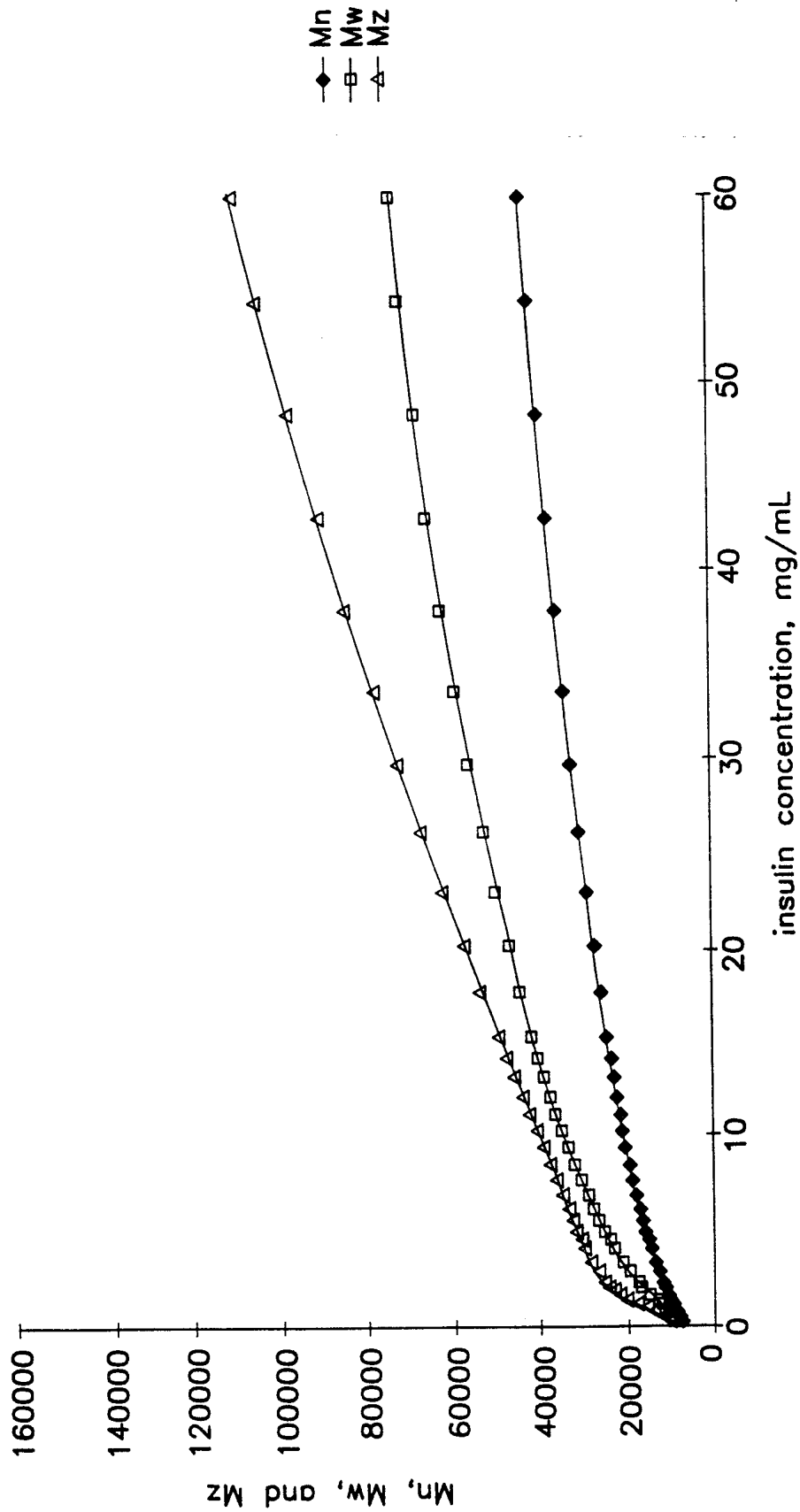

FIG. 7

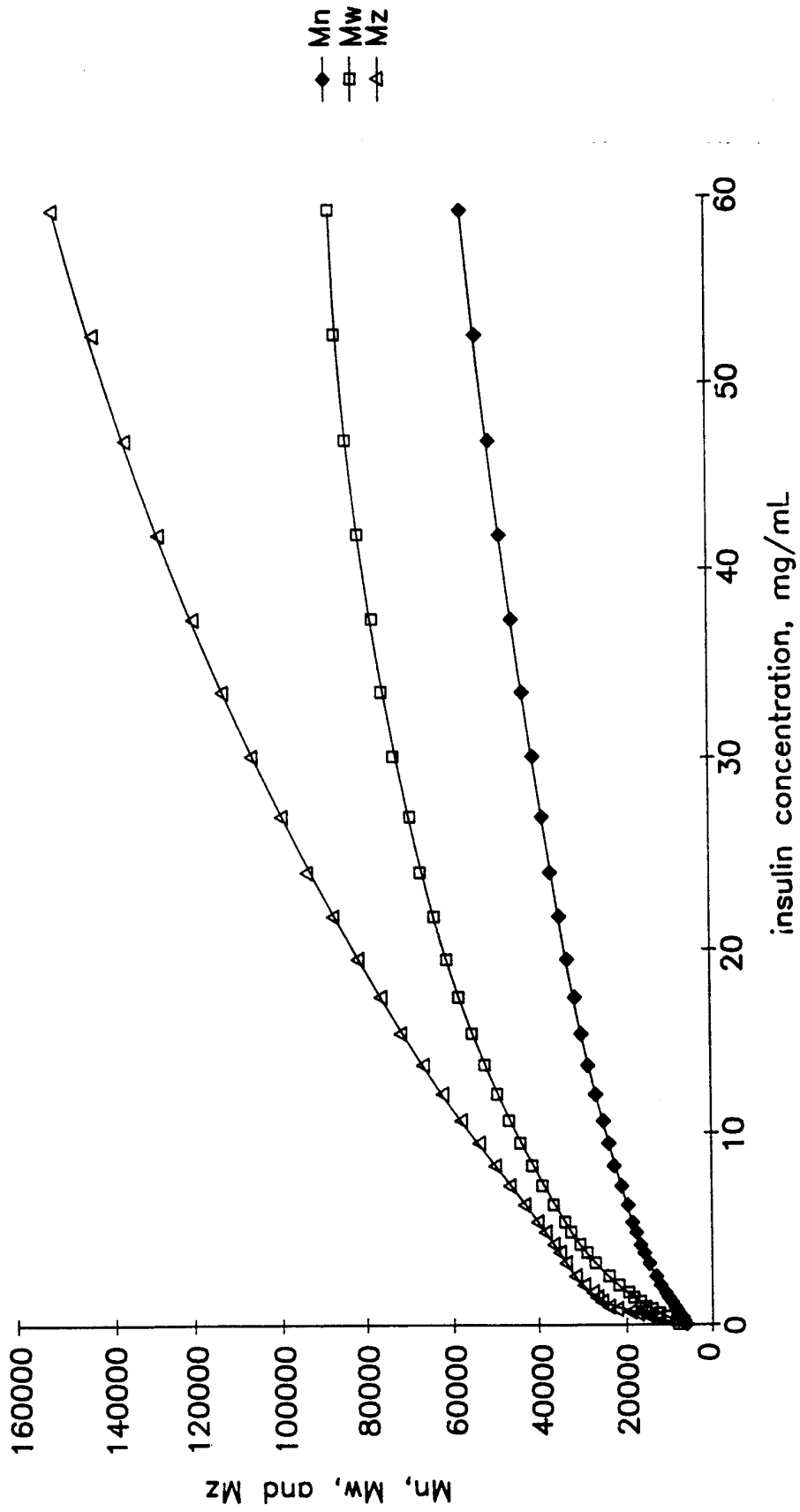

FIG. 8

# INTERNATIONAL SEARCH REPORT

International Application No

PCT/US 98/23298

**A. CLASSIFICATION OF SUBJECT MATTER**  
 IPC 6 A61K47/18 A61K38/28

According to International Patent Classification (IPC) or to both national classification and IPC

**B. FIELDS SEARCHED**

Minimum documentation searched (classification system followed by classification symbols)  
 IPC 6 A61K C07K

Documentation searched other than minimum documentation to the extent that such documents are included in the fields searched

Electronic data base consulted during the international search (name of data base and, where practical, search terms used)

**C. DOCUMENTS CONSIDERED TO BE RELEVANT**

| Category ° | Citation of document, with indication, where appropriate, of the relevant passages   | Relevant to claim No. |
|------------|--|-----------------------|
| X          | US 4 371 523 A (GRODSKY GEROLD M ET AL)<br>1 February 1983<br>see whole doc., esp. col.2,1.3 ff.<br>---  | 1                     |
| X          | WO 97 39768 A (SOERENSEN HANS HOLMEGAARD<br>;BJOERN SOEREN (DK); LANGBALLE PETER (DK)<br>30 October 1997<br>see whole doc., esp. abstract; p.7, 1.21<br>ff; p.15, 1.26 ff<br>--- | 1-3                   |
| Y          | US 5 312 326 A (MYERS ROBERT M ET AL)<br>17 May 1994<br>see whole doc. esp. claims and col.11, 1.6<br>---  | 11-15,<br>19-28       |
| Y          | US 5 312 326 A (MYERS ROBERT M ET AL)<br>17 May 1994<br>see whole doc. esp. claims and col.11, 1.6<br>---  | 11-15,<br>19-21       |

Further documents are listed in the continuation of box C.

Patent family members are listed in annex.

° Special categories of cited documents :

- "A" document defining the general state of the art which is not considered to be of particular relevance
- "E" earlier document but published on or after the international filing date
- "L" document which may throw doubts on priority claim(s) or which is cited to establish the publication date of another citation or other special reason (as specified)
- "O" document referring to an oral disclosure, use, exhibition or other means
- "P" document published prior to the international filing date but later than the priority date claimed

- "T" later document published after the international filing date or priority date and not in conflict with the application but cited to understand the principle or theory underlying the invention
- "X" document of particular relevance; the claimed invention cannot be considered novel or cannot be considered to involve an inventive step when the document is taken alone
- "Y" document of particular relevance; the claimed invention cannot be considered to involve an inventive step when the document is combined with one or more other such documents, such combination being obvious to a person skilled in the art.
- "&" document member of the same patent family

Date of the actual completion of the international search

Date of mailing of the international search report

19 April 1999

28/04/1999

Name and mailing address of the ISA  
 European Patent Office, P.B. 5818 Patentlaan 2  
 NL - 2280 HV Rijswijk  
 Tel. (+31-70) 340-2040, Tx. 31 651 epo nl,  
 Fax: (+31-70) 340-3016

Authorized officer

Müller, F

## INTERNATIONAL SEARCH REPORT

International Application No

PCT/US 98/23298

## C.(Continuation) DOCUMENTS CONSIDERED TO BE RELEVANT

| Category | Citation of document, with indication, where appropriate, of the relevant passages  | Relevant to claim No. |
|----------|---|-----------------------|
| Y        | WO 96 11705 A (PHARMADERM RESEARCH & DEV LTD ;GERTNER AVI (IL); RUBINSTEIN YOSEF)<br>25 April 1996<br>see whole doc, esp. claims and expl.4,<br>p.27<br>---   | 22-28                 |
| X        | US 5 580 856 A (PRESTRELSKI STEVEN J ET AL) 3 December 1996<br>see whole doc., esp. claims; col.6,1.40<br>and table 1<br>---  | 1,2                   |
| A        | LOUGHEED W.D. ET AL.,: "Insulin<br>aggregation in artificial delivery systems"<br>DIABETOLOGIA,<br>vol. 19, no. 1, - July 1980 pages 1-9,<br>XP002100222<br>cited in the application<br>see the whole document<br>--- |                       |
| A        | WO 92 12999 A (NOVONORDISK AS)<br>6 August 1992<br>see whole doc. esp. claims and page 1. 120<br>ff<br>---  |                       |
| A        | EP 0 692 489 A (LILLY CO ELI)<br>17 January 1996<br>see the whole document<br>-----   |                       |

# INTERNATIONAL SEARCH REPORT

Information on patent family members

International Application No

PCT/US 98/23298

| Patent document cited in search report      | A | Publication date | Patent family member(s) | Publication date |
|---|---|------------------|-------------------------|------------------|
| US 4371523                                  | A | 01-02-1983       | NONE                    |                  |
| <hr style="border-top: 1px dashed black;"/> |   |                  |                         |                  |
| WO 9739768                                  | A | 30-10-1997       | AU 2634397 A            | 12-11-1997       |
|   |   |                  | CA 2252535 A            | 30-10-1997       |
|   |   |                  | CZ 9803207 A            | 17-03-1999       |
|   |   |                  | EP 0904099 A            | 31-03-1999       |
|   |   |                  | NO 984951 A             | 23-10-1998       |
| <hr style="border-top: 1px dashed black;"/> |   |                  |                         |                  |
| US 5312326                                  | A | 17-05-1994       | WO 9525562 A            | 28-09-1995       |
|   |   |                  | US 5466217 A            | 14-11-1995       |
|   |   |                  | DE 69407061 D           | 08-01-1998       |
|   |   |                  | DE 69407061 T           | 04-06-1998       |
|   |   |                  | EP 0751801 A            | 08-01-1997       |
|   |   |                  | JP 9510387 T            | 21-10-1997       |
| <hr style="border-top: 1px dashed black;"/> |   |                  |                         |                  |
| WO 9611705                                  | A | 25-04-1996       | US 5707641 A            | 13-01-1998       |
|   |   |                  | AU 3761895 A            | 06-05-1996       |
|   |   |                  | CA 2202612 A            | 25-04-1996       |
|   |   |                  | EP 0785798 A            | 30-07-1997       |
| <hr style="border-top: 1px dashed black;"/> |   |                  |                         |                  |
| US 5580856                                  | A | 03-12-1996       | NONE                    |                  |
| <hr style="border-top: 1px dashed black;"/> |   |                  |                         |                  |
| WO 9212999                                  | A | 06-08-1992       | AT 136907 T             | 15-05-1996       |
|   |   |                  | AU 1190292 A            | 27-08-1992       |
|   |   |                  | DE 69210011 D           | 23-05-1996       |
|   |   |                  | DE 69210011 T           | 05-09-1996       |
|   |   |                  | EP 0568594 A            | 10-11-1993       |
|   |   |                  | JP 6506444 T            | 21-07-1994       |
|   |   |                  | US 5597796 A            | 28-01-1997       |
| <hr style="border-top: 1px dashed black;"/> |   |                  |                         |                  |
| EP 0692489                                  | A | 17-01-1996       | US 5504188 A            | 02-04-1996       |
|   |   |                  | AU 697794 B             | 15-10-1998       |
|   |   |                  | AU 2168195 A            | 04-01-1996       |
|   |   |                  | BR 9502798 A            | 04-06-1996       |
|   |   |                  | CA 2151563 A            | 17-12-1995       |
|   |   |                  | CN 1128271 A            | 07-08-1996       |
|   |   |                  | CZ 9501541 A            | 14-02-1996       |
|   |   |                  | FI 952930 A             | 17-12-1995       |
|   |   |                  | HU 73495 A              | 28-08-1996       |
|   |   |                  | JP 8169899 A            | 02-07-1996       |
|   |   |                  | NO 952334 A             | 18-12-1995       |
|   |   |                  | NZ 272358 A             | 20-12-1996       |
|   |   |                  | PL 309099 A             | 27-12-1995       |