

(No Model.)

J. L. HORNIG.  
ELECTRIC SWITCH.

No. 566,760.

Patented Sept. 1, 1896.

*Fig. 1*

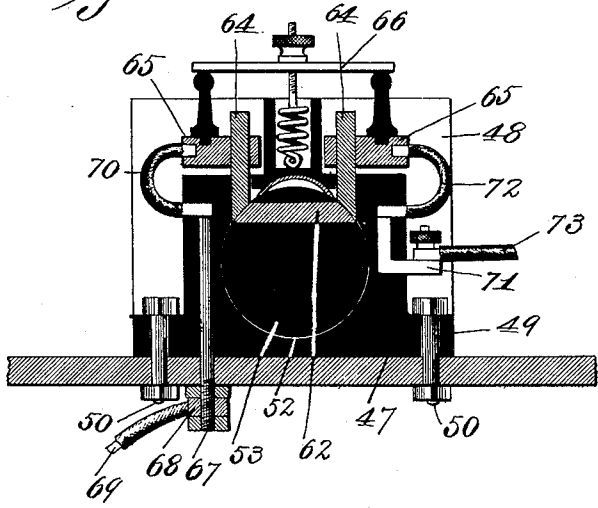

*Fig. 2*

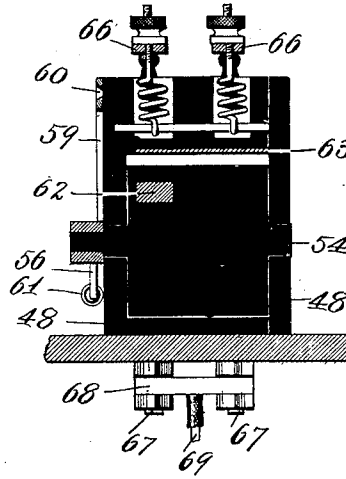

*Fig. 3*

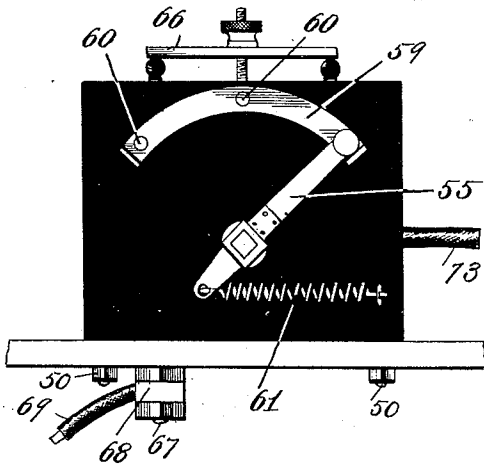

*Fig. 4*

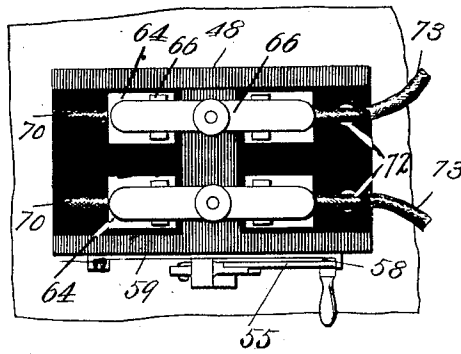

*Fig. 5*

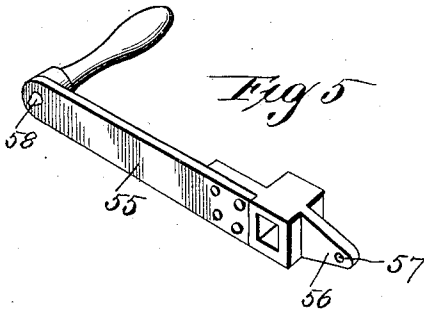

*Fig. 6*

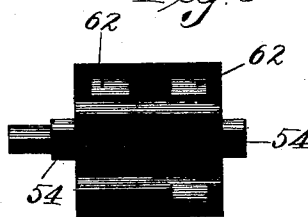

Attest  
John L. Timson  
W.P. Smith

Inventor:  
Julius L. Hornig.  
By Higdon & Higdon & Longan  
Atty's.

# UNITED STATES PATENT OFFICE.

JULIUS L. HORNIG, OF ST. LOUIS, MISSOURI.

## ELECTRIC SWITCH.

SPECIFICATION forming part of Letters Patent No. 566,760, dated September 1, 1896.

Application filed February 26, 1896. Serial No. 580,890. (No model.)

*To all whom it may concern:*

Be it known that I, JULIUS L. HORNIG, of the city of St. Louis, State of Missouri, have invented certain new and useful Improvements in Electric Switches, of which the following is a full, clear, and exact description, reference being had to the accompanying drawings, forming a part hereof.

My invention relates to an improved electric switch; and it consists in the novel construction, combination, and arrangement of parts hereinafter described and claimed.

In the drawings, Figure 1 is a vertical sectional view taken through the center of my improved switch. Fig. 2 is a vertical transverse sectional view of my improved switch. Fig. 3 is a side elevation of the switch. Fig. 4 is a top plan view thereof. Fig. 5 is a view in perspective of an operating-handle used in my improved switch. Fig. 6 is a side elevation of a disk carrying contact plates.

Referring by numerals to the accompanying drawings, a single block of insulating material 47 is constructed with vertical side walls 48 and perforated ears 49. Bolts 50 pass through said perforated ears 49 and through a suitable base 51.

Formed in the center of the block 47 is a recess 52, in which is mounted for rotation a disk 53, that is constructed with integral trunnions 54, that extend through the walls 48. Located upon that trunnion 54 that passes through the front wall 48 is a crank-handle 55, constructed with an integral downwardly-pending portion 56, having an aperture 57 therein. Formed integral with the inner face of the crank-handle 55, adjacent the upper end thereof is a lug or projection 58. A segment 59 is arranged upon the face of the front wall 48, and upon said segment rides the outer end of the crank-handle 55. Said segment is provided at its center and both ends with apertures 60, in which the lug or projection 58 is adapted to engage. A retractile coil-spring 61 is secured in the aperture 57 in the projection 56, and to one side of the front wall 48. Passing through the disk 53 in such a manner as that their ends will appear upon the periphery of said disk at slight distances apart are metallic plates 62, and said plates lie in parallel vertical planes with each other but at right angles.

A shield 63 is attached to the block 47 di-

rectly above the disk 53 and between the lower ends of the brushes 66. This shield is preferably composed of mica, but may be made of any equivalent elastic non-conducting material and presses yieldingly against the periphery of the disk 53, and its object is to prevent the carrying of sparks by the periphery of the disk from one brush to the other while rotating the disk and breaking one contact and making another. This shield may be constructed of any suitable material, such as mica, and of any suitable size or shape, the essential feature being that it is non-conducting and presses closely against the periphery of the disk, and yet possesses sufficient elasticity to accommodate itself to the surface of the disk without acting to prevent ready rotation of the disk.

Brushes 64 extend vertically downward through the block 47, the lower ends of which ride directly upon the periphery of the disk 53, there being one pair of these brushes each of the plates 62. These brushes 64 are held in brush-holders 65, that are provided with tension devices 66.

Extending upwardly through one side of each block 47 is a pair of rods 67, the lower ends of which are screw-threaded, and located upon said lower ends and held thereto is a transversely-arranged metallic bar 68, with which a suitable conductor 69 connects. Suitable conductors 70 connect the upper ends of these rods 67 with the brush-holders 65 on one side of the block 47. Located in the opposite end of the block 47 is a pair of rectangular plates 71, with the upper ends of which the ends of suitable conductors 72 are connected that lead to the remaining pair of brush-holders. To the other ends of these plates 71 are secured the ends of suitable conductors 73.

The operation is as follows: The conductor-plates 62 are so arranged in the disk 53 as that when the front one of said plates 62 occupies a horizontal plane, as shown in Fig. 1, the same will be in connection with the front pair of the brushes 64. When said conductor-plates 62 are in this position, the crank-handle 55 is in the position as shown in Fig. 3, the lug 58 on said crank-handle being in the right-hand aperture 60 in the segment 59. The left-hand brush of each pair of the brushes 64 are constantly connected with the

conductor 69 through the horizontal plate 68, the rods 67, and the conductors 70. When the crank-handle 55 is arranged with the lug 58 in the right-hand aperture 60 of the segment 59, as shown in Fig. 3, the current passes from the conductor 69 through the end of the horizontal bar 68, up the front rod 67, through the front conductor 70, through the brush-holder 65, through the left-hand brush 64 of the front pair of the brushes 64, through the front conductor-plate 62, through the left-hand brush 64 of the front pair of brushes, through the right-hand brush-holder 65 of the front pair of brush-holders, through the front conductor 72, and through the front rectangular plate 71 to the front conductor 73. When the crank-handle 55 is in a vertical position and the lug 58 is in the center one of the apertures 60 in the segment 59, neither one of the conductor-plates 62 will be in contact with the brushes and the current is closed. When the crank-handle 55 is positioned so that the lug 58 is in the left-hand one of the apertures 60 in the segment 59, the rear one of the conductor-plates 62 connects the ends of the rear pair of brushes 64 and then the current passes from the conductor 69 through the horizontal bar 68 to the rear one of the rods 67, through the rear one of the conductors 70, through the rear one of the left-hand brush-holders 65, through the rear one of the left-hand brushes 64, through the rear conductor-plate 62, through the rear right-hand brush 64, through the rear right-hand brush-holder 65, through the rear conductor 72, and through the rear rectangular plate 71 to the rear conductor 73.

A switch of my improved construction is simple, inexpensive, very compact, is positive in action, and very efficient in use.

I claim—

1. In an improved switch, a suitable block, a disk mounted for rotation within said block, a spring-actuated handle for rotating said disk, means for holding said handle in a set position, conductor-plates arranged in said disk at right angles to each other, brush-holders arranged above said block, suitable tension devices for said brush-holders, brushes passing vertically through said brush-holders, the lower ends thereof engaging upon the periphery of the disk and adapted to contact with the ends of the conductor-plates, suitable connections from two of said brush-holders to a single conductor, and suitable connections leading from the remaining brush-holders.

2. In an improved switch, a block of insulating material, a disk of insulating material mounted for rotation within said block, a spring-actuated handle for rotating said disk, a lug on said handle, a segment adjacent said handle and having apertures to be engaged by said lug to hold said handle in a set position, conductor-plates arranged in said disk at right angles to each other, brush-holders arranged above said block, brushes carried

by said brush-holders and arranged to have their lower ends engage the periphery of said disk in such a way that when one of said conductor-plates is in a horizontal position it will connect the ends of a pair of said brushes, all the brushes on one side of said disk being connected to a single conductor and each of the brushes on the opposite side of said disk being connected to a conductor independent of each of the other brushes.

3. In an improved switch, a rotating disk, conductor-plates passing through said disk and a spark-arrester consisting of non-conducting elastic material so positioned as to engage yieldingly against the periphery of said disk, substantially as specified.

4. In an improved switch, a suitable block, a disk mounted for rotation within said block, a spark-arrester consisting of non-conducting elastic material so positioned as to engage yieldingly against the periphery of the disk between the points of contact between the disk and the brushes, a spring-actuated handle for rotating said disk, means for holding said handle in a set position, conductor-plates arranged in said disk at right angles to each other, brush-holders arranged above said block, suitable tension devices for said brush-holders, brushes passing vertically through said brush-holders, the lower ends thereof engaging upon the periphery of the disk and adapted to contact with the ends of the conductor-plates, suitable connections from two of said brush-holders to a single conductor, and suitable connections leading from the remaining brush-holders.

5. In an improved switch, a block of insulating material, a disk of insulating material mounted for rotation within said block, a spark-arrester consisting of non-conducting elastic material so positioned as to engage yieldingly against the periphery of the disk between the points of contact between the disk and the brushes, a spring-actuated handle for rotating said disk, a lug on said handle, a segment adjacent said handle and having apertures to be engaged by said lug to hold said handle in a set position, conductor-plates arranged in said disk at right angles to each other, brush-holders arranged above said block, brushes carried by said brush-holders and arranged to have their lower ends engage the periphery of said disk in such a way that when one of said conductor-plates is in a horizontal position it will connect the ends of a pair of said brushes, all the brushes on one side of said disk being connected to a single conductor and each of the brushes on the opposite side of said disk being connected to a conductor independent of each of the other brushes.

In testimony whereof I affix my signature in presence of two witnesses.

JULIUS L. HORNIG.

Witnesses:

M. P. SMITH,  
MAUD GRIFFIN.