



US012263767B2

(12) **United States Patent**
Fitzpatrick et al.

(10) **Patent No.:** **US 12,263,767 B2**
(45) **Date of Patent:** **Apr. 1, 2025**

(54) **OCCUPANT POSITIONER**

(71) Applicant: **Faurecia Automotive Seating, LLC**,
Auburn Hills, MI (US)

(72) Inventors: **Robert C. Fitzpatrick**, Auburn Hills,
MI (US); **Jeffery T. Bonk**, Auburn
Hills, MI (US)

(73) Assignee: **Faurecia Automotive Seating, LLC**,
Auburn Hills, MI (US)

(*) Notice: Subject to any disclaimer, the term of this
patent is extended or adjusted under 35
U.S.C. 154(b) by 260 days.

(21) Appl. No.: **17/917,717**

(22) PCT Filed: **Apr. 21, 2020**

(86) PCT No.: **PCT/US2020/029133**

§ 371 (c)(1),

(2) Date: **Oct. 7, 2022**

(87) PCT Pub. No.: **WO2021/216049**

PCT Pub. Date: **Oct. 28, 2021**

(65) **Prior Publication Data**

US 2023/0158926 A1 May 25, 2023

(51) **Int. Cl.**

B60N 2/42 (2006.01)

B60N 2/427 (2006.01)

B60N 2/68 (2006.01)

B60N 2/806 (2018.01)

(52) **U.S. Cl.**

CPC **B60N 2/4228** (2013.01); **B60N 2/42745**
(2013.01); **B60N 2/68** (2013.01); **B60N 2/806**
(2018.02)

(58) **Field of Classification Search**

CPC .. **B60N 2/4228**; **B60N 2/806**; **B60N 2/42745**;
B60N 2/68

See application file for complete search history.

(56) **References Cited**

U.S. PATENT DOCUMENTS

5,769,489 A * 6/1998 Dellanno **B60N 2/42709**
297/216.12

6,398,299 B1 6/2002 Angerer

7,077,472 B2 * 7/2006 Steffens, Jr. **B60N 2/42781**
297/216.12

(Continued)

FOREIGN PATENT DOCUMENTS

EP 1738955 B1 1/2007

EP 1935710 A2 6/2008

(Continued)

OTHER PUBLICATIONS

International (PCT) Search Report and Written Opinion for PCT/
US2020/29133 dated Jul. 27, 2020, IDFAUH19112 PCT II (47631-
317130), 8 pages.

(Continued)

Primary Examiner — Philip F Gabler

(74) *Attorney, Agent, or Firm* — Barnes & Thornburg
LLP

(57) **ABSTRACT**

An occupant support includes a seat bottom and a seat back.
The seat back is coupled to the seat bottom and includes a
headrest and a backrest. The occupant support is configured
to support an occupant resting thereon before, during, and
after an impact force is applied to the occupant support.

15 Claims, 9 Drawing Sheets

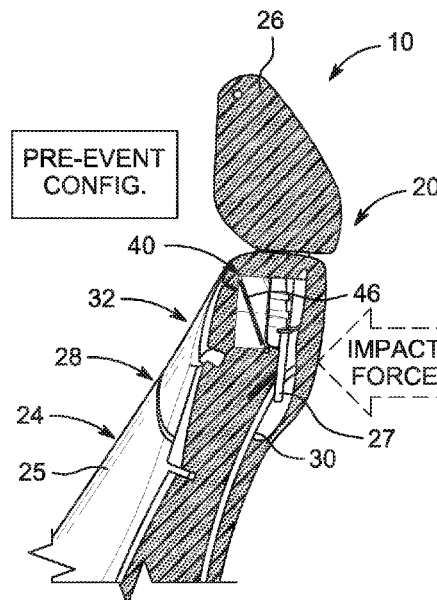

(56)

References Cited

U.S. PATENT DOCUMENTS

8,678,494 B2 * 3/2014 Nitsuma B60N 2/4228
297/216.12
8,876,206 B2 * 11/2014 Yamaguchi B60N 2/7094
297/230.12
10,752,136 B2 * 8/2020 Sugiyama B60N 2/2222
11,117,537 B2 * 9/2021 Bonk B60N 2/42709
11,447,049 B2 * 9/2022 Sekizuka B60R 21/233
2011/0215619 A1 * 9/2011 Kanda B60N 2/4228
297/216.14
2012/0001462 A1 1/2012 Cyoukyu
2012/0119551 A1 5/2012 Brncick
2013/0076092 A1 3/2013 Kulkarni

FOREIGN PATENT DOCUMENTS

FR 2946586 A1 12/2010
KR 20020046503 A 6/2002
KR 20050051755 A 6/2005
KR 20050104746 A 11/2005

OTHER PUBLICATIONS

International Search Report and Written Opinion for PCT/US2020/
029133 dated Jul. 27, 2020.

* cited by examiner

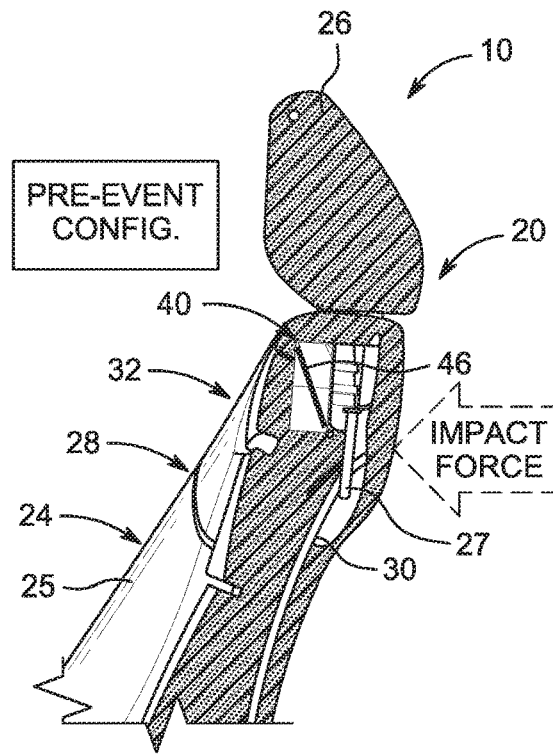

FIG. 1A

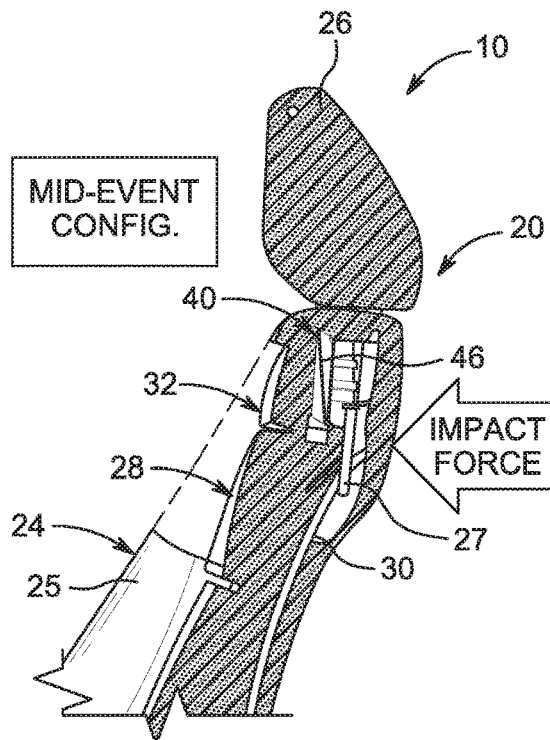

FIG. 1B

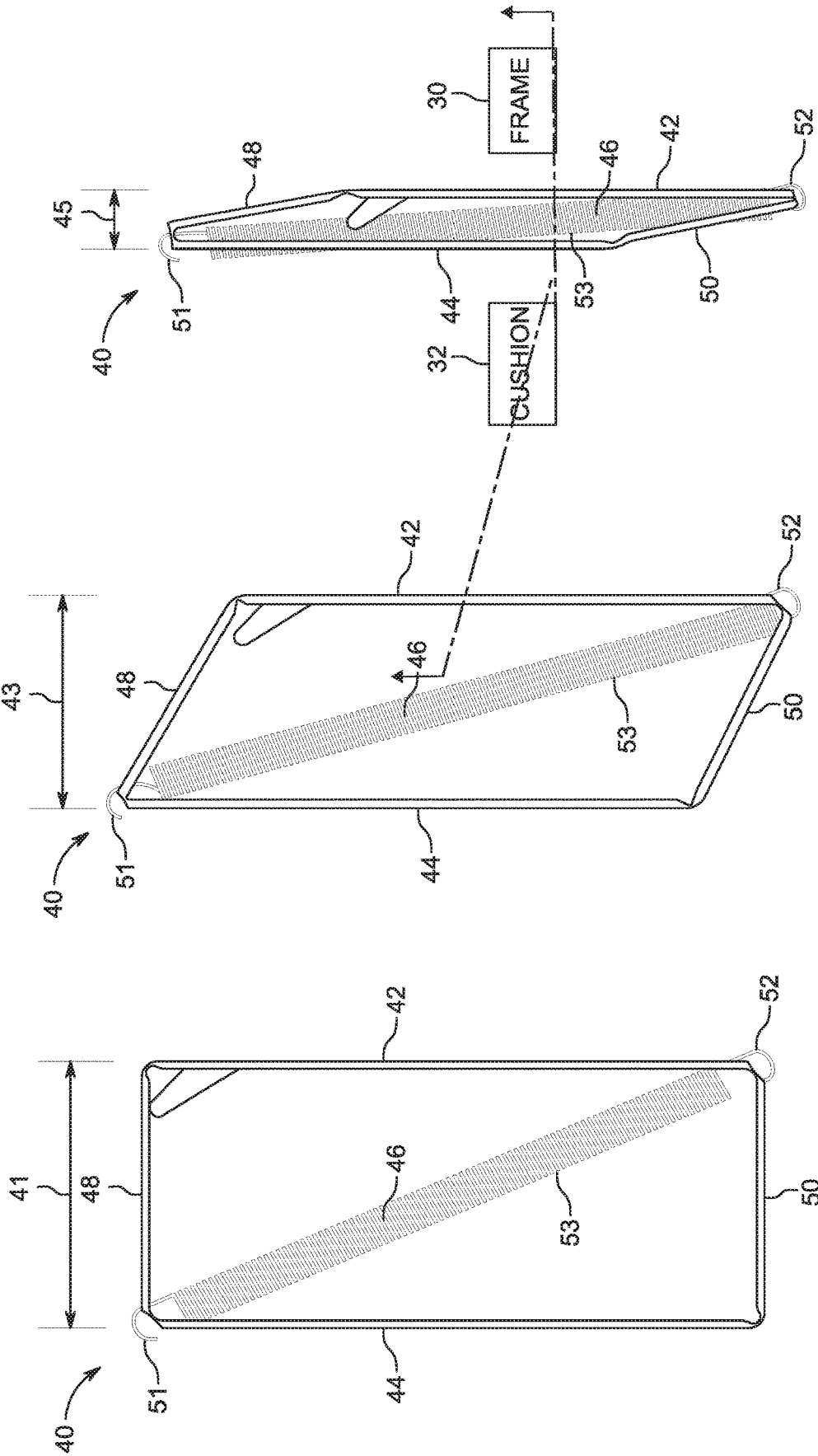
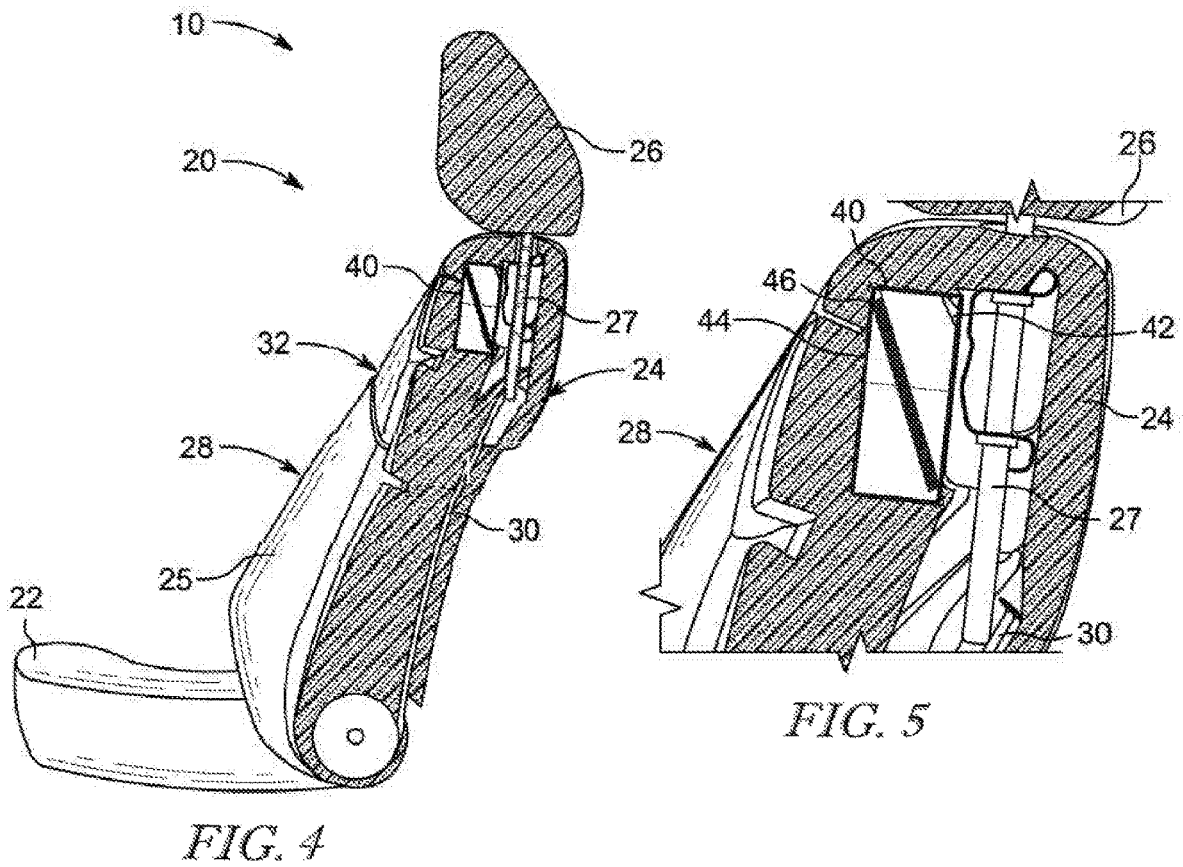
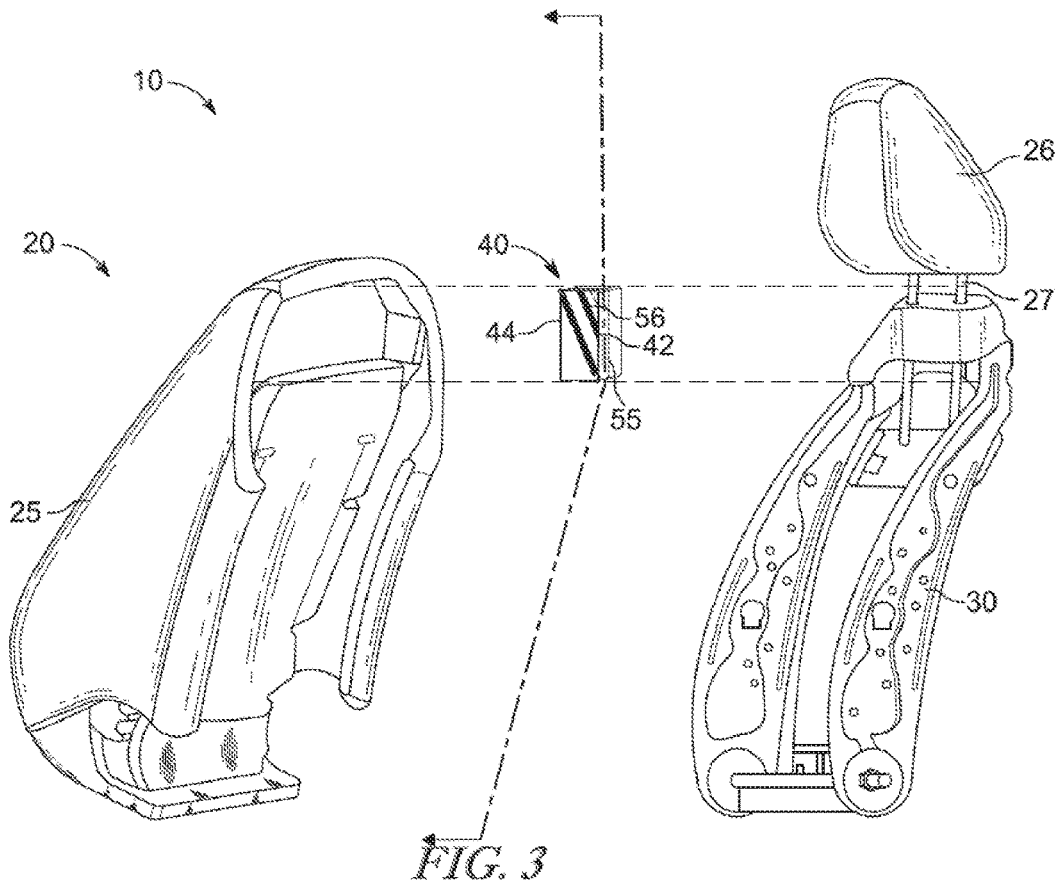
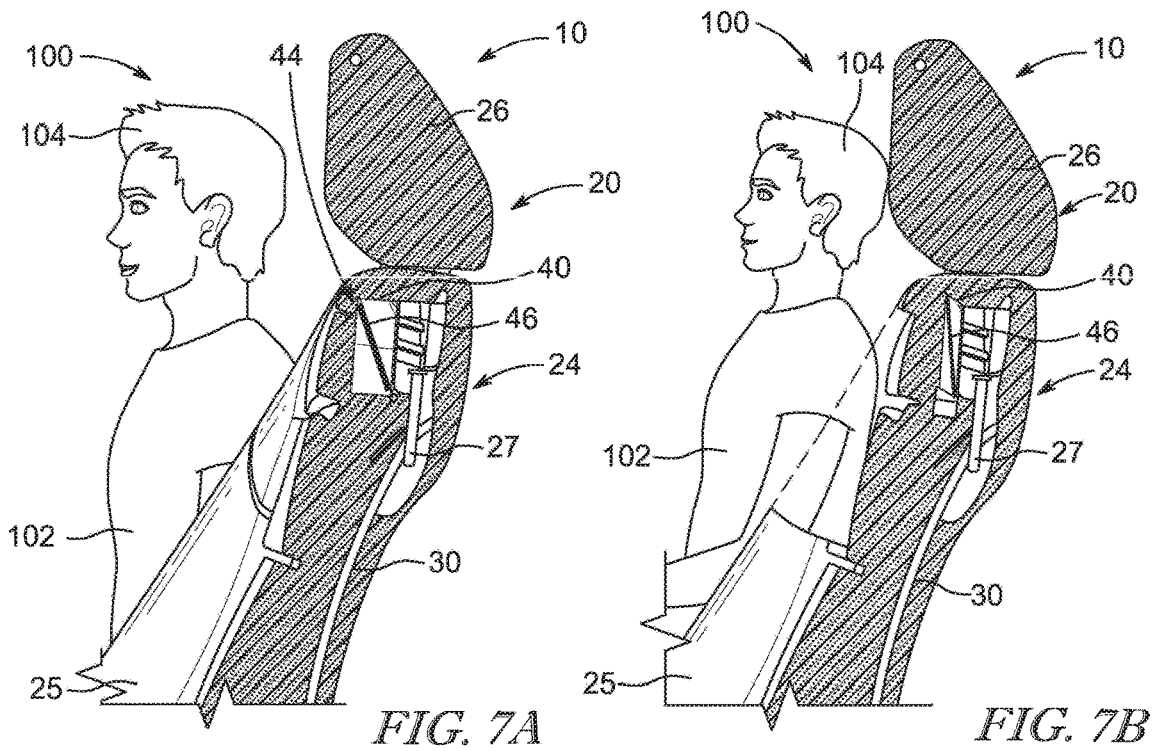
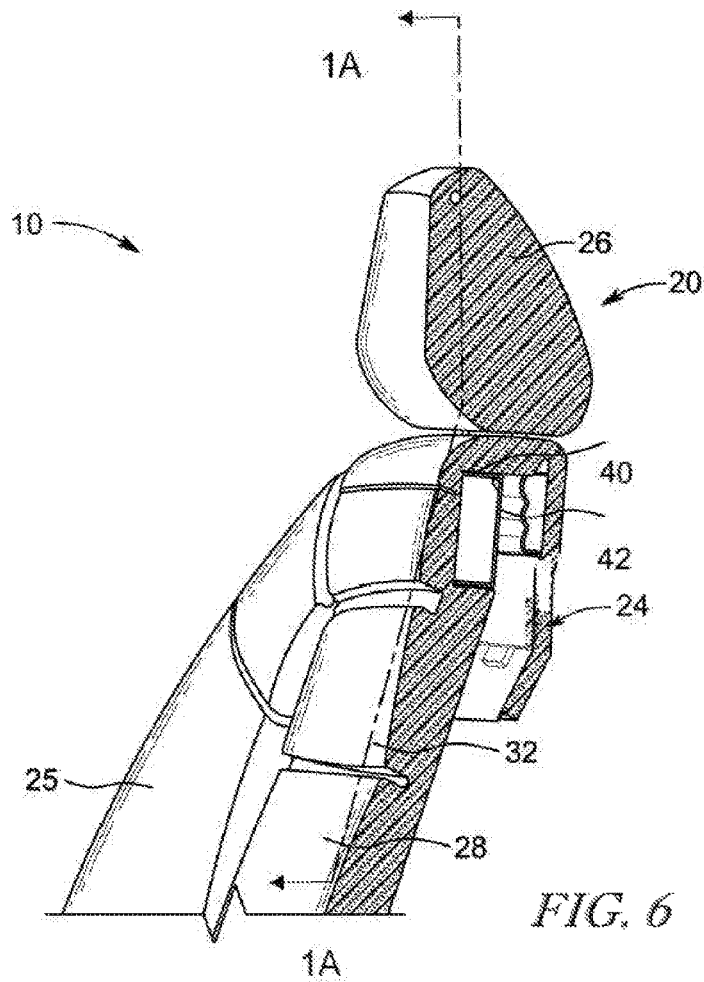

FIG. 2C

FIG. 2B

FIG. 2A





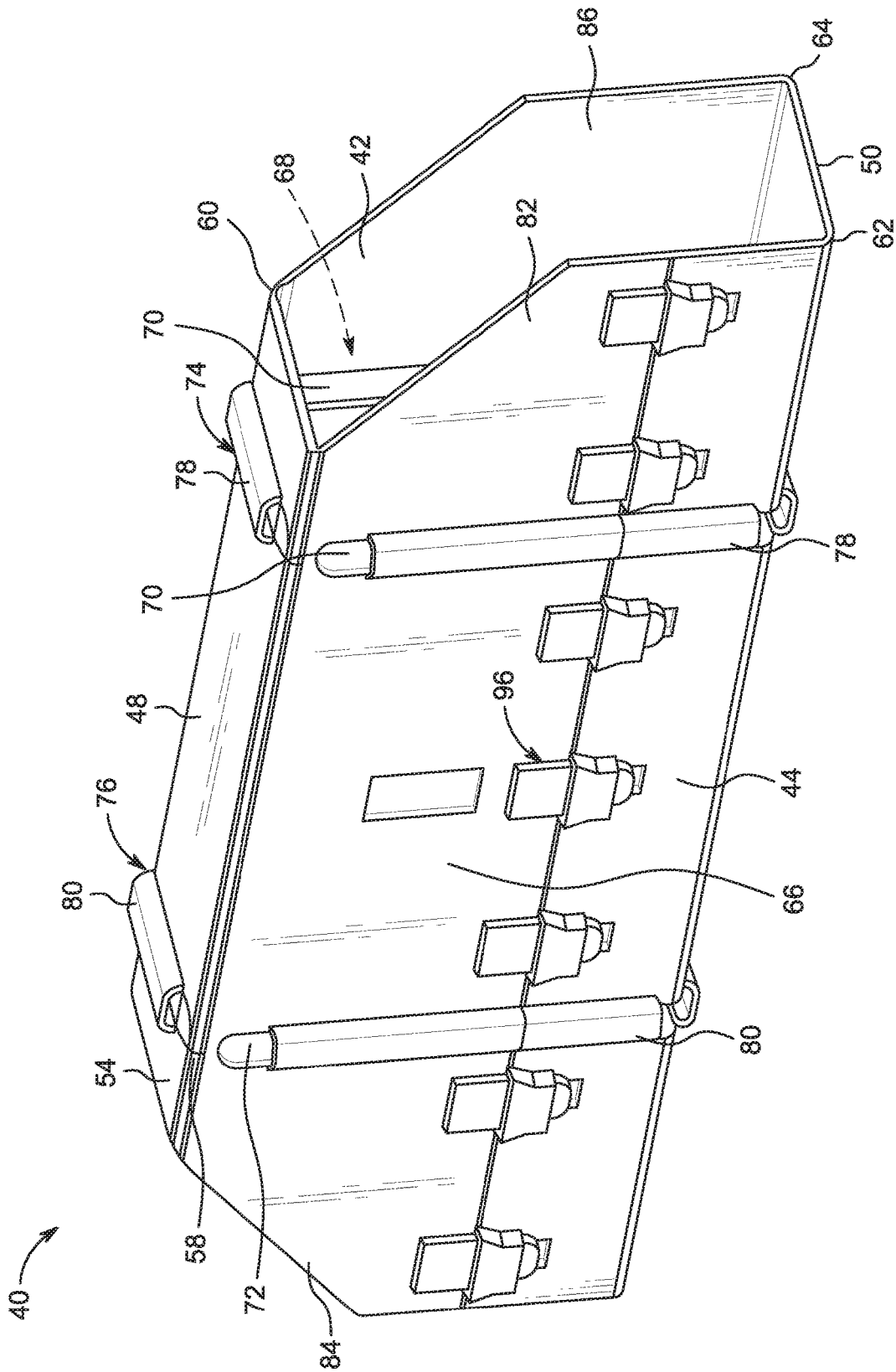

FIG. 8

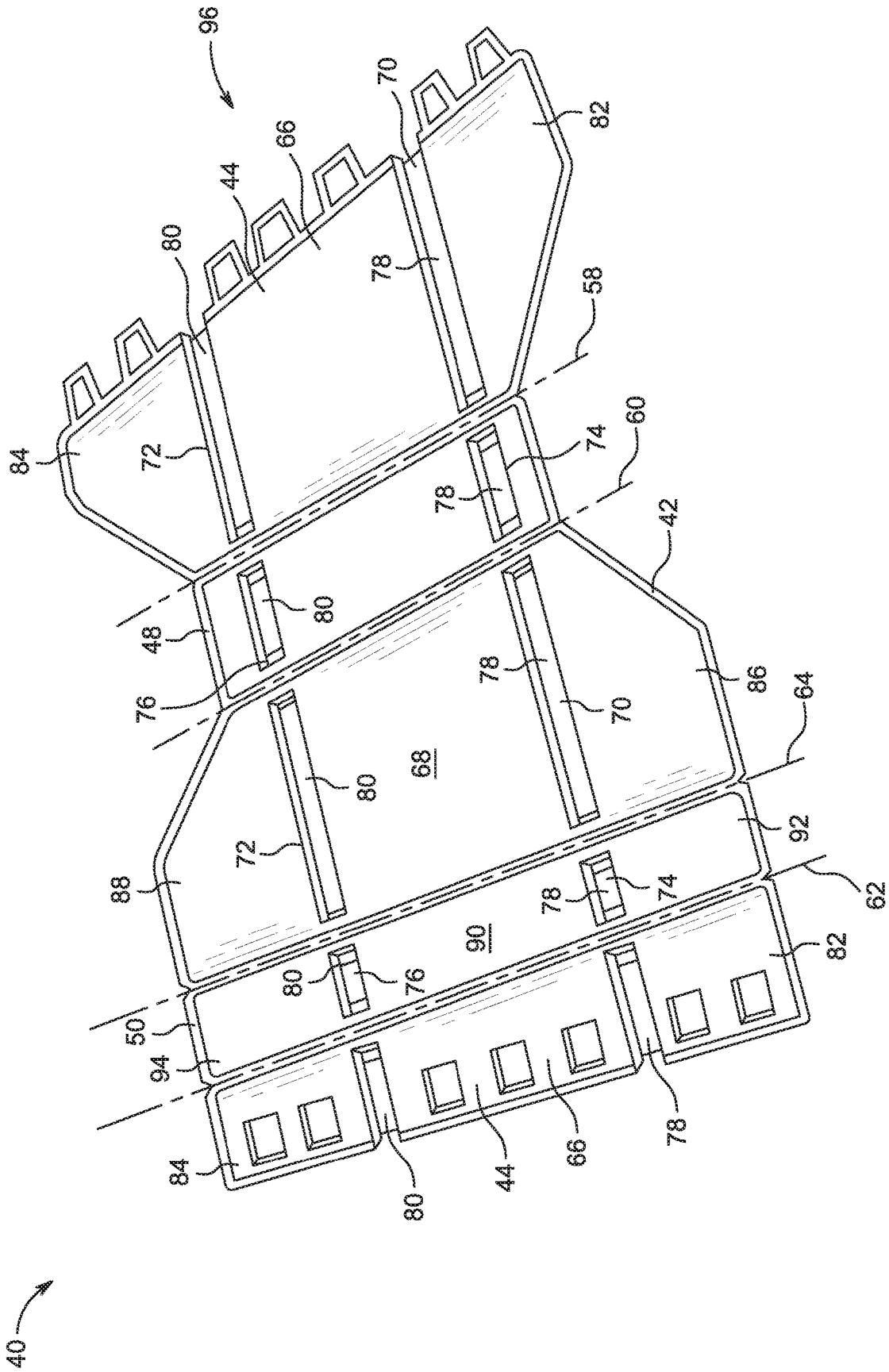

FIG. 9

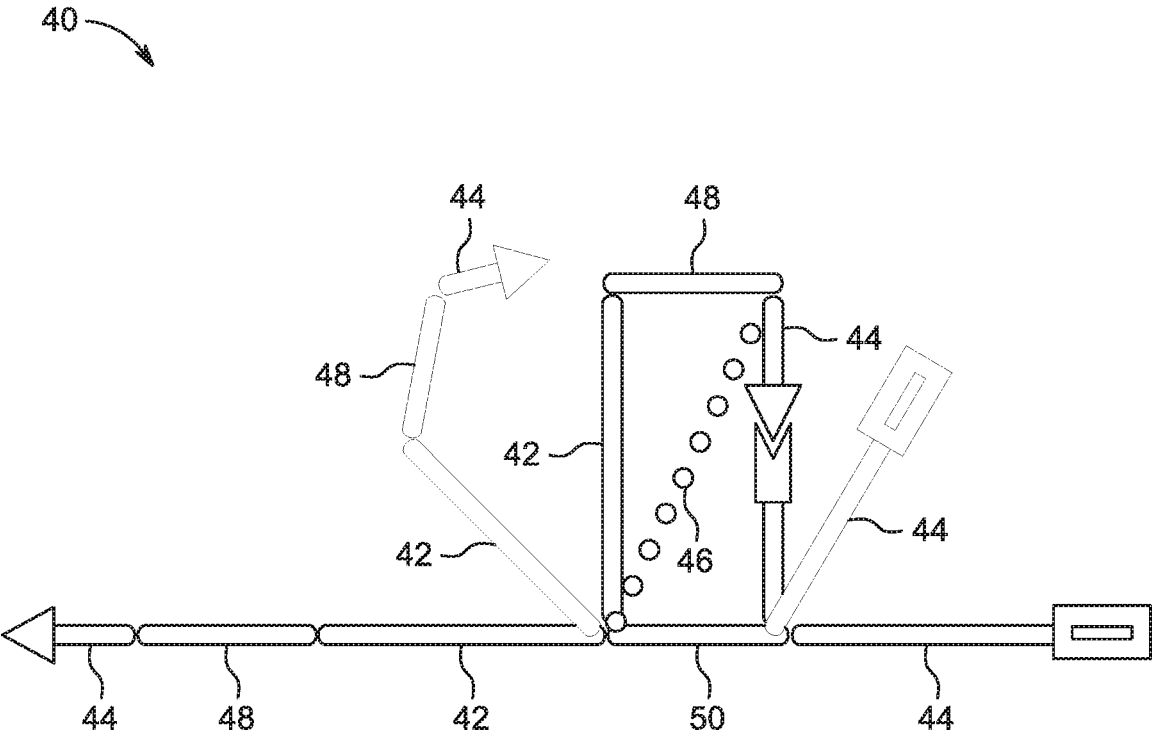

FIG. 10

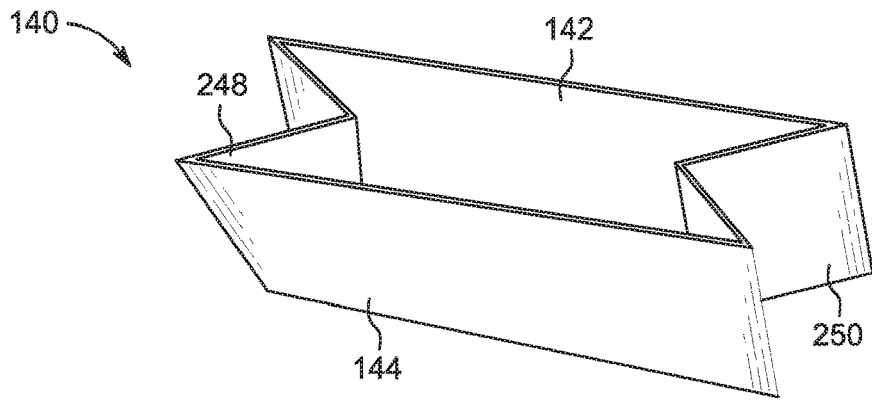

FIG. 11A

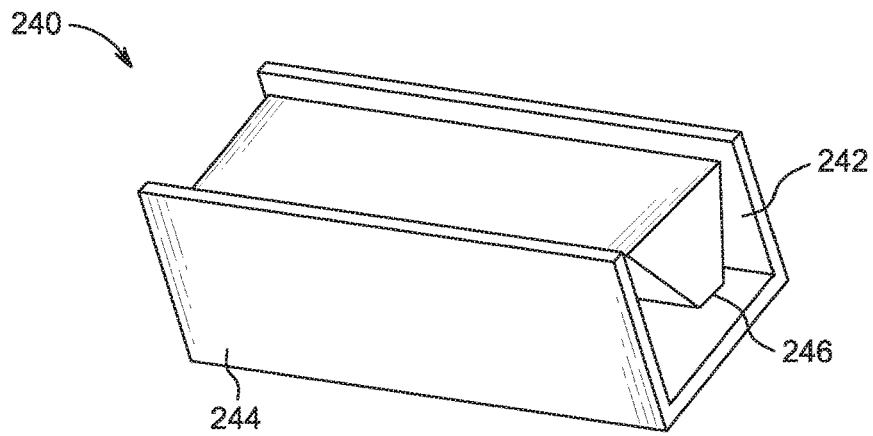

FIG. 11B

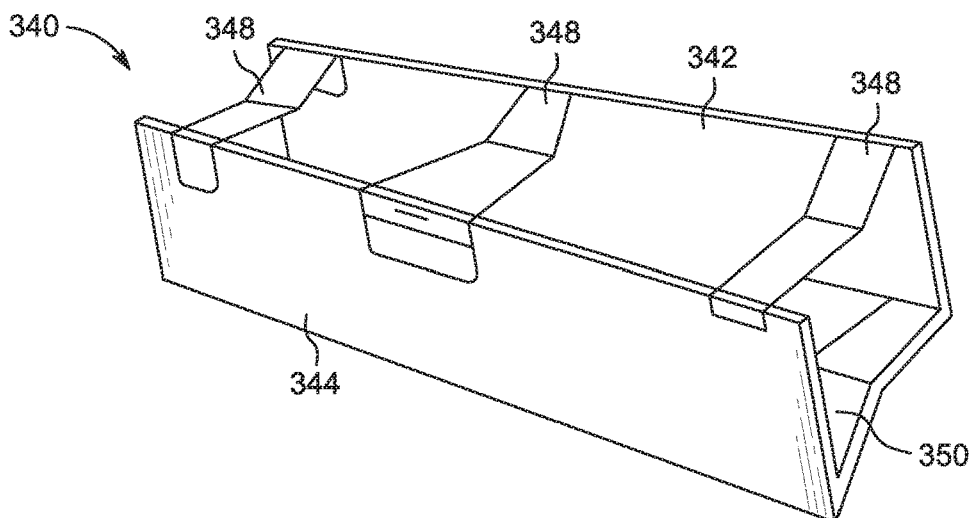

FIG. 11C

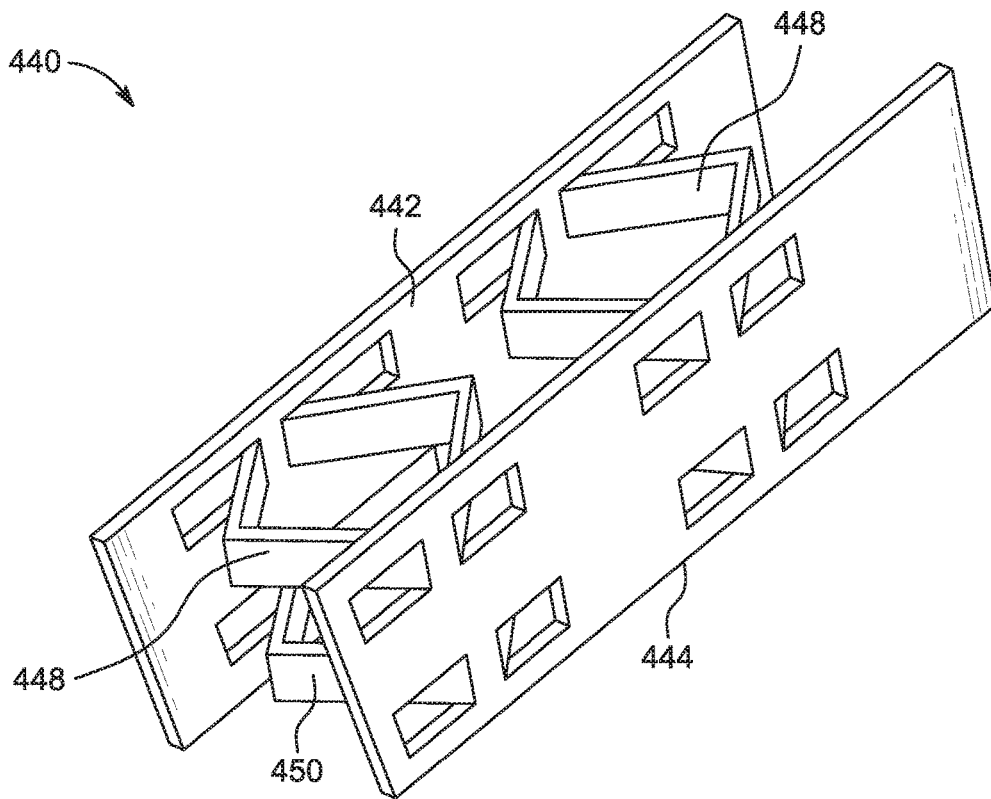

FIG. 11D

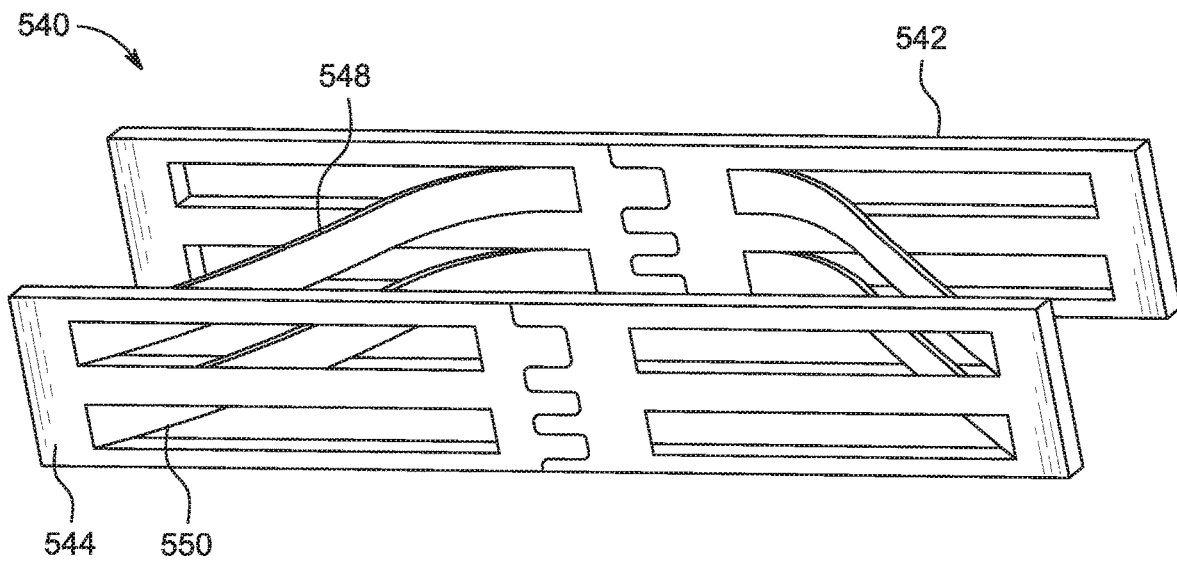

FIG. 11E

1

OCCUPANT POSITIONER**CROSS REFERENCE TO RELATED APPLICATIONS**

This application is a U.S. national stage application under 35 U.S.C. § 371 (b) of International Application No. PCT/US2020/029133 filed Apr. 21, 2020, the disclosure of which is hereby expressly incorporated by reference in their entirety.

BACKGROUND

The present disclosure relates to occupant supports, and particularly to occupant supports for vehicles. More particularly, the present disclosure relates to occupant supports including an occupant positioner configured to change a position of the occupant.

SUMMARY

According to the present disclosure, an occupant support includes a seat bottom and a seat back. The seat back is coupled to the seat bottom and arranged to extend upwardly away from the seat bottom. The seat back includes a headrest located in spaced apart relation above the seat bottom and a backrest located between the headrest and the seat bottom.

In illustrative embodiments, the occupant support further includes a reactive-occupant positioner coupled to the seat back to move therewith and is configured to arrange an occupant on the occupant support in response to an impact event so that the occupant moves from (i) a pre-event arrangement in which a torso of the occupant is arranged a first distance from a frame of the seat back so that comfort is maximized prior to application of an impact force to the occupant support, (ii) to an event arrangement in which the torso of the occupant is arranged a second distance from the frame that is less than the first distance so that a head of the occupant moves toward and engages the headrest to minimize whiplash of the occupant during the impact event, and (iii) to a post-event arrangement in which the torso of the occupant is arranged a third distance from the frame that is greater than the second distance after the impact event is complete without repair of the reactive-occupant positioner.

In illustrative embodiments, in response to the impact event, the reactive-occupant positioner changes from a pre-event configuration in which the reactive-occupant positioner causes the occupant to be in the pre-event arrangement, to an event configuration in which the reactive-occupant positioner causes the occupant to be in the event arrangement.

In illustrative embodiments, the reactive-occupant positioner includes a rear platform coupled to the seat back in a fixed position relative to the seat back and a front platform movable relative to the rear platform.

In illustrative embodiments, in the pre-event configuration, the reactive-occupant positioner has a first thickness defined between the front platform and the rear platform, in the event configuration, the reactive-occupant positioner has a second thickness defined between the front platform and the rear platform that is less than the first thickness, and, in the post-event configuration, the reactive-occupant positioner has a third thickness defined between the front platform and the rear platform that is greater than the second thickness.

Additional features of the present disclosure will become apparent to those skilled in the art upon consideration of

2

illustrative embodiments exemplifying the best mode of carrying out the disclosure as presently perceived.

BRIEF DESCRIPTIONS OF THE DRAWINGS

The detailed description particularly refers to the accompanying figures in which:

FIG. 1A is a sectional view taken along line 1A-1A of FIG. 6 showing the occupant support including a seat back and a reactive-occupant positioner coupled to the seat back, and suggesting the reactive-occupant support is configured to arrange an occupant of the occupant support in the pre-event arrangement in which a torso of the occupant is arranged a first distance from a frame of the seat back so that comfort is maximized prior to application of an impact force (phantom arrow) to the occupant support;

FIG. 1B is a view similar to FIG. 1A showing the reactive-occupant support configured to arrange an occupant of the occupant support in the event arrangement in which the torso of the occupant is arranged a second distance from the frame that is less than the first distance so that a head of the occupant engages the headrest to minimize whiplash of the occupant during the impact event;

FIG. 2A is a side view of the reactive-occupant positioner of FIG. 1A in the pre-event configuration and showing that the reactive-occupant includes a front platform, a rear platform, a first arm linkage, a second arm linkage, and a bias unit, and suggesting that, in the pre-event configuration, the reactive-occupant positioner has a thickness defined between the front platform and the rear platform;

FIG. 2B is a view similar to FIG. 2A showing the reactive-occupant positioner moving between the pre-event configuration and the event configuration to cause the reactive-occupant positioner to have a thickness that is less than the thickness shown in FIG. 2A;

FIG. 2C is a view similar to FIG. 2B showing the reactive-occupant positioner in the event configuration in which the reactive-occupant positioner has a thickness that is less than the thicknesses shown in FIGS. 2A and 2B;

FIG. 3 is an exploded perspective assembly view of the occupant support of FIG. 1A showing that the occupant support includes, from left to right, a backrest cushion, the reactive-occupant positioner, and the frame of the seat back and suggesting that the reactive-occupant positioner is retained in a space formed between the backrest cushion and the frame;

FIG. 4 is a side view of the occupant support of FIG. 1A showing the seat back with a portion removed to show the frame of seat back and the reactive-occupant positioner in the pre-event configuration;

FIG. 5 is an enlarged portion of FIG. 4 showing the rear platform of the reactive-occupant positioner coupled to the frame and the reactive-occupant positioner in the pre-event configuration;

FIG. 6 is a perspective view of the occupant support of FIG. 1A showing the seat back including the backrest having the backrest cushion, the headrest, and the reactive-occupant positioner in the pre-event configuration;

FIG. 7A is a diagrammatic view of the occupant support of FIG. 1A showing an occupant positioned in the occupant support and suggesting that the seat back cushion along with the reactive-occupant positioner arranges the occupant in the pre-event arrangement in which the torso of the occupant is arranged a first distance from the frame of the seat back so that comfort is maximized prior to application of an impact force to the occupant support;

FIG. 7B is a view similar to FIG. 7A showing the occupant positioned in the occupant support after an impact event and suggesting that the seat back cushion along with the reactive-occupant positioner arranges the occupant in the event arrangement in which the torso of the occupant is arranged a second distance from the frame that is less than the first distance so that a head of the occupant engages the headrest to minimize whiplash of the occupant during the impact event;

FIG. 8 is a perspective view of the reactive-occupant positioner of FIG. 1A showing the reactive-occupant positioner in the pre-event configuration;

FIG. 9 is a perspective view of the reactive-occupant positioner of FIG. 8 showing the reactive-occupant positioner in an unfolded configuration in which the attachment points of locking mechanisms of the front platform are disconnected;

FIG. 10 is a side diagrammatic view of the reactive-occupant positioner of FIGS. 8 and 9 showing the reactive-occupant positioner changing from a fully unfolded configuration, to a transition configuration, and to an assembled configuration;

FIG. 11A is a perspective view of another embodiment of a reactive-occupant positioner in accordance with the present disclosure showing that the bias unit includes a first collapsible hinge and a second collapsible hinge, the first and second collapsible hinges are configured to collapse inwardly when the reactive-occupant positioner moves from the pre-event configuration to the event configuration;

FIG. 11B is a perspective view of another embodiment of a reactive-occupant positioner in accordance with the present disclosure;

FIG. 11C is a perspective view of another embodiment of a reactive-occupant positioner in accordance with the present disclosure showing that the bias unit includes first, second, third, fourth, fifth, and sixth collapsible hinges, the first, second, third, fourth, fifth, and sixth collapsible hinges are configured to collapse inwardly when the reactive-occupant positioner moves from the pre-event configuration to the event configuration;

FIG. 11D is a perspective view of another embodiment of a reactive-occupant positioner in accordance with the present disclosure showing that the bias unit includes first, second, third, and fourth rectangular flat springs arranged between the front platform and the rear platform, the first, second, third, and fourth flat springs are configured to compress inwardly to allow the front platform to move toward the rear platform when the reactive-occupant positioner moves from the pre-event configuration to the event configuration; and

FIG. 11E is a perspective view of another embodiment of a reactive-occupant positioner in accordance with the present disclosure showing that the bias unit includes first and second curved flat springs arranged between the front platform and the rear platform, each of the first and second flat springs are configured to compress inwardly to allow the front platform to move toward the rear platform when the reactive-occupant positioner moves from the pre-event configuration to the event configuration.

DETAILED DESCRIPTION

A first embodiment of a reactive-occupant positioner 40 of an occupant support 10 is shown in FIGS. 1A-10. In one example, the reactive-occupant positioner 40 of the occupant support 10 is coupled to a seat back 24 of the occupant support 10 and is configured to arrange an occupant 100 of

the occupant support 10 in at least three arrangements in response to an impact event to maximize comfort and safety of an occupant during the impact event. A second embodiment of a reactive-occupant positioner 140 is shown in FIG. 11A. Another embodiment of a reactive-occupant positioner 240 is shown in FIG. 11B. Yet another embodiment of a reactive-occupant positioner 340 is shown in FIG. 11C. A further embodiment of a reactive-occupant positioner 440 is shown in FIG. 11D. An additional embodiment of a reactive-occupant positioner 540 is shown in FIG. 11E.

An occupant support 10 for a vehicle in accordance with the present disclosure is shown in FIGS. 1A, 1B, and 3-7B. The occupant support 10 includes a vehicle seat 20 having a seat bottom 22 and a seat back 24 arranged to extend upwardly away from the seat bottom 22. The seat back 24 includes a headrest 26 and backrest 28 located between the headrest 26 and the seat bottom 22. The reactive-occupant positioner 40 is coupled to the seat back 24 and is configured to arrange the occupant 100 in various positions (arrangements) on the occupant support 10 before, during, and after an impact event of the vehicle. In particular, the reactive-occupant positioner 40 is configured to collapse during an impact event such that the occupant's head 104 contacts relatively quickly the headrest 26, thus minimizing potential effects of whiplash during the impact event. Additionally, the reactive-occupant positioner 40 is configured to self-reset and return to the initial position within the seat back 24 after the impact event, thus minimizing the need for the occupant support 10 to be repaired after the impact event.

The reactive-occupant positioner 40 includes a rear platform 42 and a front platform 44 as shown in FIGS. 1A-10. The rear platform is coupled to a frame 30 of the seat back 24 in a fixed position relative to the frame 30. The front platform 44 is located forward of the rear platform 42 and is configured to move relative to the rear platform 42 as shown in FIGS. 1A-10. The reactive-occupant positioner 40 further includes a first arm linkage 48 and a second arm linkage 50 that extend between the rear platform 42 and the front platform 44. The reactive-occupant positioner 40 further includes a bias unit 46 disposed between the rear platform 42 and the front platform 44 that biases the reactive-occupant positioner 40 towards a pre-impact event position in which the reactive-occupant positioner 40 is fully expanded as shown in FIGS. 1A and 2A.

During an impact event of the vehicle, the occupant 100 of the occupant support 10 may experience a whiplash effect if the headrest 26 is not positioned at a predetermined distance away from the occupant's head 104. In one example, some regulations require that the headrest 26 be positioned very close to the occupant's head 104 in order to minimize the possibility of whiplash. The headrest 26 being very close to the occupant's head 104 may be uncomfortable to the occupant 100, for example, for occupants 100 with larger heads or large hairstyles. This may increase the pain point for the occupant 100. The reactive-occupant positioner 40 allows for the headrest 26 to be placed further back on the seat back 24 and thus further away from the occupant's head 104 by collapsing rapidly during an impact event of the vehicle and allowing the occupant's head 104 to quickly contact the headrest 26. As a result, potential whiplash effects to the occupant 100 are minimized.

The reactive-occupant positioner 40 is arranged in the backrest 28 of the seat back 24, replacing a volume of foam cushion used in this area of the backrest 28 as shown in FIGS. 1A, 1B, and 3-7B. During an impact event, the reactive-occupant positioner 40 is configured to collapse due to loading by the occupant 100 due to the impact event. This

allows for the occupant **100** to sink into the backrest **28** faster, allowing the occupant's head **104** to contact the headrest **26** sooner, reducing force on the occupant's neck. The bias unit **46** of the reactive-occupant positioner **40** then biases the reactive-occupant positioner **40** back to the starting position.

In the illustrative embodiment, the reactive-occupant positioner **40** is configured to arrange the occupant **100** in response to the impact event so that the occupant **100** moves from a pre-event arrangement, in which the reactive-occupant positioner **40** is in a pre-event configuration (FIGS. 1A, 2A, and 3-7A), to an event arrangement, in which the reactive-occupant positioner **40** is in an event configuration (FIGS. 1B, 2C, and 7B), and to a post-event arrangement (which may be the pre-event arrangement) in which the reactive-occupant positioner **40** is in a post-event configuration (which may be the pre-event configuration).

The occupant support **10** includes the vehicle seat **20** as shown in FIGS. 1A, 1B, and 3-7B. The vehicle seat **20** is arranged in the vehicle as any one of the vehicle seats in a vehicle. For example, the vehicle seat **20** may be the passenger side front seat, the driver side front seat, the passenger side rear seat, or the driver side rear seat. The vehicle seat **20** includes the seat bottom **22** and the seat back **24** and is configured to support the occupant **100** of the vehicle seat **20**, as shown in FIG. 4. The seat bottom **22** is arranged to overlie a floor of the vehicle and is arranged substantially parallel with the floor. The seat bottom **22** may be configured to raise and lower, as well as pivot, relative to the floor of the vehicle.

The seat back **24** extends substantially vertically away from the seat bottom **22** and supports the back of the occupant **100** of the vehicle seat **20** as shown in FIGS. 1A, 1B, 4, and 6-7B. The seat back **24** includes a backrest cushion **32** formed on a front surface of the backrest **28** of the seat back **24** and configured to engage and support the occupant's torso **102**. The seat back **24** further includes left and right bolsters **25** arranged outwardly of the backrest cushion **32** on the sides of the seat back **24** (a portion of the bolster **25** is removed for clarity in FIGS. 1B and 7B). A headrest **26** extends upwardly out of a top surface of the seat back **24** via headrest supports **27** and is positioned to support the occupant's head **104**.

The interior of the seat back **24** includes the frame **30** of the seat back **24**, the headrest supports **27**, and the reactive-occupant positioner **40**, as shown in exploded view of FIG. 3. The frame **30** is formed from a rigid material and maintains the general shape of the seat back **24** when assembled. The headrest supports **27** extend through a top portion of the frame **30** and position the headrest **26** above the frame **30**, and thus above the seat back **24**.

The seat back **24** is formed to include a positioner-receiving space **34** as shown in FIG. 3. The positioner-receiving space **34** is an open space formed to contain the reactive-occupant positioner **40**. In the illustrative embodiment, the reactive-occupant positioner **40** is coupled to the top portion of the frame **30** of the vehicle seat **20** via the rear platform **42** being fastened to the top portion of the frame **30** as shown in FIG. 3. The top portion of the frame **30** may be trapezoid-shaped so as to match the general trapezoidal shape of the reactive-occupant positioner **40** in some embodiments. In other embodiments, the reactive-occupant positioner **40** may not be coupled fixedly to the frame **30**, but instead may rest within the positioner-receiving space **34**, held in place by the top portion of the frame **30**.

The reactive-occupant positioner **40** is shown in detail in FIGS. 2A, 2B, 5, and 8-10. As discussed above, during an

impact event of the vehicle, in particular a rear impact of the vehicle, the occupant's torso **102** will be forced backwards into the backrest cushion **32** (see "impact force" in FIGS. 1A and 1B). When the occupant's torso **102** loads the backrest cushion **32** rearward, the backrest cushion **32** loads the front platform **44** of the reactive-occupant positioner **40** and pushes the front platform **44** rearwards toward the rear platform **42** (see FIGS. 2B and 2C). The rapid collapse of the reactive-occupant positioner **40** during the impact event of the vehicle allows the occupant's head **104** to quickly contact the headrest **26**. As a result, potential whiplash effects to the occupant **100** are reduced.

The reactive-occupant positioner **40** includes the rear platform **42** coupled to a frame **30** of the seat back **24** and the front platform **44** arranged forward of the rear platform **42** and configured to move relative thereto as shown in FIGS. 1A-10. The reactive-occupant positioner **40** further includes the first and second arm linkages **48**, **50** that extend between the rear platform **42** and the front platform **44**. The first arm linkage **48** is pivotably coupled to a first top edge of the front platform **44** and a second top edge of the rear platform **42**. The second arm linkage **50** is coupled pivotably to a first bottom edge of the front platform **44** and a second bottom edge of the rear platform **42**. The reactive-occupant positioner **40** further includes the bias unit **46** disposed between the rear platform **42** and the front platform **44** that biases the reactive-occupant positioner **40** towards the pre-event configuration and the post-event configuration.

The bias unit **46** is coupled to an upper portion of the front platform **44** and to a lower portion of the rear platform **42** as shown in FIGS. 2A-2C and 8-10. The bias unit **46** is configured to bias the front platform **44** away from the rear platform **42** toward the pre-event configuration of the reactive-occupant positioner **40** prior to application of the impact force to the occupant support **10** and toward the post-impact configuration of the reactive-occupant positioner **40** after application of the impact force to the occupant support **10**.

When the reactive-occupant positioner **40** moves from the pre-event configuration to the event configuration, the first arm linkage **48** and the second arm linkage **50** pivot upwardly and toward the rear platform such that a biasing force of the bias unit **46** increases as shown in FIGS. 2A-2C. When the reactive-occupant positioner **40** moves from the event configuration to the post-event configuration, the first arm linkage **48** and the second arm linkage **50** pivot downwardly and away from the rear platform **42** such that a biasing force of the bias unit **46** decreases as shown in FIGS. 2A-2C. When the reactive-occupant positioner **40** is in the event configuration, the front platform **44** is moved as far as possible toward the rear platform **42** until the front platform **44** hits a stopper **47** arranged on the rear platform **42**.

The reactive-occupant positioner **40** is shown in greater detail in FIGS. 8 and 9. In the illustrative embodiment, the front platform **44** and the rear platform **42** are formed to have the same shape, in particular, a trapezoidal shape. The rear platform **42** includes a rear main portion **68** that is generally rectangular shaped, and a first wing **86** and a second wing **88** that extend longitudinally outwardly away from the rear main portion **68**. The first and second wings **86**, **88** are formed to be the same height as the rear main portion **68** so as to create the trapezoidal shape. Likewise, the front platform **44** includes a front main portion **66** that is generally rectangular shaped, and a first wing **82** and a second wing **84** that extend longitudinally outwardly away from the front main portion **66**. The first and second wings **82**, **84** are formed to be the same height as the front main portion **66** so as to create the trapezoidal shape.

In the illustrative embodiment, the front platform **44**, the rear platform **42**, the first arm linkage **48**, and the second arm linkage **50** are formed of the same material. The material may be metal or steel such that the reactive-occupant positioner **40** is capable of withstanding substantial impact forces imparted by the occupant **100** of the occupant support **10**. Other rigid materials such as heavy duty plastics may be used as well, so long as the reactive-occupant positioner **40** is capable of withstanding typical impact forces during vehicle impact events.

The first arm linkage **48** and the second arm linkage **50** are formed as similarly shaped rectangular pieces, as shown in FIGS. **8** and **9**. In the illustrative embodiment, the width of the first and second arm linkages **48**, **50** is approximately half the height of the front and rear platforms **44**, **42**. The second arm linkage **50** is longer than the first arm linkage **48** in order to accommodate for the bottom portion of each wing **82**, **84**, **86**, **88** of the front platform **44** and the rear platform **42**. Specifically, the second arm linkage **50** includes a first extension **92** and a second extension **94** that each extend outwardly away from a main portion **90** of the second arm linkage **50**.

The first arm linkage **48** is coupled pivotably to the first top edge of the front platform **44** via a first hinge **58** and to the second top edge of the rear platform **42** via a second hinge **60**. The second arm linkage **50** is coupled pivotably to the first bottom edge of the front platform **44** via a third hinge **62** and to the second bottom edge of the rear platform **42** via a fourth hinge **64**. The hinges **58**, **60**, **62**, **64** may be formed of a resilient material capable of securely holding the structure of the reactive-occupant positioner together while also permitting bending of the hinges **58**, **60**, **62**, **64**. In some embodiments, the first and second hinges **58**, **60** are living hinges.

The bias unit **46** includes a first coupling member **51**, a second coupling member **52**, and a first biasing member **53** as shown in FIGS. **2A-2C**. The first coupling member **51** is arranged on a first end of the first biasing member **53** and is coupled to a top portion of the front platform **44**. The second coupling member **52** is arranged on a second end of the first biasing member **53** and is coupled to a bottom portion of the rear platform **42**. In the illustrative embodiment, the bias unit **46** further includes a third coupling member **54**, a fourth coupling member **55**, and a second biasing member **56**. The third coupling member **54** is arranged on a first end of the second biasing member **56** and is coupled to the top portion of the front platform **44**, and the fourth coupling member **55** is arranged on a second end of the second biasing member **56** and is coupled to the bottom portion of the rear platform **42**.

In some embodiments, the first and second biasing members **53**, **56** are springs, in particular, tension springs as shown in FIGS. **2A-2C**. In other embodiments, the biasing members **53**, **56** may include other types of biasing means, such as using resilient materials such as rubber. The bias unit **46** of the reactive-occupant positioner **40** includes more than two biasing members, such as three or four biasing members. It can be further envisioned that the bias unit **46** of the reactive-occupant positioner **40** only includes a single biasing member, so long as the biasing force of the single biasing member is capable of moving the reactive-occupant positioner **40** to the post-event configuration.

The front main portion **66** and the rear main portion **68** each have a first opening **70** configured to accommodate the first biasing member **53** when the reactive-occupant positioner **40** is moved to the event configuration and is in the event configuration, as shown in FIGS. **8** and **9**. The front

main portion **66** and the rear main portion **68** each further include a second opening **72** configured to accommodate the second biasing member **56** when the reactive-occupant positioner **40** is moved to the event configuration and is in the event configuration, as also shown in FIGS. **8** and **9**.

Likewise, the first arm linkage **48** and the second arm linkage **50** each have a third opening **74** configured to accommodate the first biasing member **53** when the reactive-occupant positioner **40** is moved to the event configuration and is in the event configuration, and a fourth opening **76** configured to accommodate the second biasing member **56** when the reactive-occupant positioner **40** is moved to the event configuration and is in the event configuration.

Each of the front platform **44**, the rear platform **42**, the first arm linkage **48**, and the second arm linkage **50** includes a first opening cover **78** and a second opening cover **80** that are arranged to cover a majority of each of the first, second, third, and fourth openings **70**, **72**, **74**, **76**, as shown in FIGS. **8** and **9**. The covers **78**, **80** prevent portions of the biasing member **53**, **56** from contacting the inner surface of the backrest cushion **32** and the frame **30** when the reactive-occupant positioner **40** is moved to the event configuration and is in the event configuration. Each of the first and second opening covers **78**, **80** of the front platform **44** is arranged to extend outwardly away from the rear platform **42**. Likewise, each of the first and second opening covers **78**, **80** of the first arm linkage **48** is arranged to extend away from the second arm linkage **50**. Likewise, each of the first and second opening covers **78**, **80** of the rear platform **42** is arranged to extend toward the frame **30** of the seat back **24** and away from the front platform **44**.

In the illustrative embodiment, the first coupling member **51** and the third coupling member **54** each include a hook member that extends through a respective portion of the third opening **74** and the fourth opening **76** of the first arm linkage **48** that is not covered by the first and second opening covers **78**, **80** of the first arm linkage **48**. Likewise, the second coupling member **52** and the fourth coupling member **55** each include a hook member that extends through a respective portion of the first opening **70** and the second opening **72** of the rear surface of platform **42** that is not covered by the first and second opening covers **78**, **80** of the rear surface of platform **42**. In other embodiments, the biasing members **53**, **56** may be attached to the first top edge of the front platform **44** and to the second bottom edge of the rear platform **42** via other fastening means, so long as the biasing members **53**, **56** are capable of expanding and contracting within the reactive-occupant positioner **40**.

In some embodiments, the front platform **44**, including the front main portion **66**, the first wing **82**, and the second wing **84**, includes a top portion and a bottom portion that are coupled together via a plurality of locking mechanisms **96**. The locking mechanism **96** are latches as shown in FIGS. **8** and **9**. In other embodiments, the locking mechanisms **96** may be configured as clasps, clamps, catches, adhesives, combinations thereof, or any other suitable mechanisms that would securely hold the front platform **44** together. The separation of the front platform **44** into two portions allows for efficient assembly of the reactive-occupant positioner **40**. As can be seen in FIGS. **9** and **10**, during assembly, the reactive-occupant positioner **40** may be folded upwardly (see FIG. **10**) such that the top portion of the front platform **44** moves toward the bottom portion of the front platform **44**. The top and bottom portions are then locked in place via the locking mechanisms **96**, and then the biasing members **53**, **56** may be inserted and arranged in place within the reactive-occupant positioner **40**.

In some embodiments, the front and rear platforms **44**, **42** may be configured as different shapes, with the front and rear platforms **44**, **42** not being the same shape. Moreover, the front and rear platforms **44**, **42** may be sized differently such that the first and second arm linkages **48**, **50** are not half as wide as the platforms **42**, **44** are high, as described above.

The various arrangements of the occupant **100** and the configurations of the reactive-occupant positioner **40** will be described in detail with reference to FIGS. **1A-10**. Before an impact event of the vehicle, the occupant **100** is arranged in the pre-event arrangement, as shown in FIGS. **1A**, **2A**, and **4-7A**. In the pre-event arrangement, the occupant's torso **102** is arranged at a first distance **31** from the frame **30** of the seat back **24** (see FIG. **7A**) so that comfort is maximized prior to the impact event. In order to keep the occupant **100** in the pre-event arrangement before the impact event, the reactive-occupant positioner **40** is in a pre-event configuration, as shown in FIGS. **1A**, **2A**, and **4-7A**. In the pre-event configuration, the reactive-occupant positioner **40** has a first thickness **41** defined between the front platform **44** and the rear platform **42**, as shown in FIG. **2A**.

Once the vehicle is involved in a collision, in particular a rear collision, an impact force (see FIGS. **1A** and **1B**) will be applied to the occupant support **10**. As the occupant **100** experiences the impact force, the occupant **100** will be forced rearwards into the backrest cushion **32**, which is subsequently forced rearwards into the front platform **44**. The backrest cushion **32** will compress as well during this movement. Once this happens, the front platform **44** of the reactive-occupant positioner **40** begins to move rearward, as shown in FIG. **2B**. The reactive-occupant positioner **40** assumes a thickness **43** in a mid-impact position, as shown in FIG. **2B**. As the front platform **44** begins to move rearward, the bias unit **46** begins to become tensioned. As can be seen in FIGS. **2A-2C**, the spring of the bias unit **46** is expanded by the first arm linkage **48** moving upwardly and rearwardly and by the front platform **44** moving upwardly and rearwardly.

After the impact force has been applied to the occupant support **10** and the occupant **100** of the occupant support **10** has sunken fully into the seat back **24** by pushing rearward on the backrest cushion **32**, the occupant **100** is in the event arrangement and the reactive-occupant positioner **40** is in the event configuration, as shown in FIGS. **1B**, **2C**, and **7B**. In the event arrangement of the occupant **100**, the occupant's torso **102** is arranged at a second distance **33** from the frame **30** of the seat back **24** (see FIG. **7B**) that is less than the first distance **31** so that the occupant's head **104** engages the headrest **26** (see FIG. **7B**). In this arrangement, whiplash of the occupant **100** is minimized during the impact event due to the occupant **100** rapidly moving rearward and the occupant's head **104** rapidly contacting the headrest **26**.

The occupant **100** being in the event arrangement is enabled by the reactive-occupant positioner **40** moving to and being in the event configuration, as shown in FIGS. **1B**, **2C**, and **7B**. In the event configuration, the reactive-occupant positioner **40** has a second thickness **45** defined between the front platform **44** and the rear platform **42** that is less than the first thickness **41**. In the event configuration, the reactive-occupant positioner **40** is fully collapsed. Specifically, the front platform **44** is moved rearward as far as possible toward the rear platform **42** such that the inner surface of the front platform **44** contacts the stopper **47**. Furthermore, the biasing members **53**, **56** are fully tensioned.

After the impact event is complete, the occupant **100** may move to a post-event arrangement and the reactive-occupant

positioner **40** moves to a post-event configuration. In the post-event arrangement, the occupant's torso **102** is arranged a third distance from the frame **30** that is greater than the second distance. Specifically, the reactive-occupant positioner **40** moving to the post-event configuration will move the backrest cushion **32** back towards its original position on the seat back **24**. In some embodiments, the third distance is about equal to the first distance, and in other embodiments, the third distance is equal to the first distance. In this case, the post-event configuration and the pre-event configuration of the reactive-occupant positioner **40**, and as such the post-event arrangement and the pre-event arrangement of the occupant **100**, are the same. The returning of the backrest cushion **32**, and as such the seat back **24**, to their original configurations after the impact event allow the occupant support **10** to continue to be used in the vehicle without repair of the seat back **24** or the reactive-occupant positioner **40**.

In a second embodiment, the occupant support **10** includes a reactive-occupant positioner **140** including a bias unit **146** having a first collapsible hinge **148** and a second collapsible hinge **150**, as shown in FIG. **11A**. The first collapsible hinge **148** is arranged on a first side end of a front platform **144** and a corresponding first side end of a rear platform **142**. The second collapsible hinge **150** is arranged on a second side end of the front platform **144** and a corresponding second side end of the rear platform **142**. The first and second collapsible hinges **148**, **150** are configured to collapse inwardly when the reactive-occupant positioner **140** moves from the pre-event configuration to the event configuration. In the illustrative embodiment, the reactive-occupant positioner **140** does not include the first and second arm linkages **48**, **50** described above, and instead is open on the top and bottom of the reactive-occupant positioner **140**.

In a third embodiment, the occupant support **10** includes a reactive-occupant positioner **240** as shown in FIG. **11B**. The reactive-occupant positioner **240** including a bias unit **246** arranged to extend between a front platform **244** and a rear platform **242** as shown in FIG. **11B**.

In a fourth embodiment, the occupant support **10** includes a reactive-occupant positioner **340** including a bias unit **346** having a plurality of collapsible hinges **348**, **350**, as shown in FIG. **11C**. A first plurality of collapsible hinges **348** include first, second, and third collapsible hinges **348** arranged on a first top edge of a front platform **344** and a first top edge of a rear platform **342**. A second plurality of collapsible hinges **350** includes fourth, fifth, and sixth collapsible hinges **350** arranged on a first bottom edge of the front platform **344** and a second bottom edge of the rear platform **342**. The first, second, third, fourth, fifth, and sixth collapsible hinges **348**, **350** are configured to collapse inwardly when the reactive-occupant positioner moves from the pre-event configuration to the event configuration. Similarly to second embodiment of the reactive-occupant positioner **140**, the reactive-occupant positioner **340** does not include the first and second arm linkages **48**, **50** described above, and instead is open on the top and bottom of the reactive-occupant positioner **340**.

In a fifth embodiment, the occupant support **10** includes a reactive-occupant positioner **440** including a bias unit **446** having rectangular flat springs, as shown in FIG. **11D**. Specifically, the bias unit **446** includes first and second rectangular flat springs **448** arranged between a front platform **444** and a rear platform **442**. Third and fourth rectangular flat springs **450** are arranged beneath the first and second rectangular platforms **448** between the front platform **444** and the rear platform **442**. The first, second, third, and

fourth flat springs **448, 450** are configured to compress inwardly to allow the front platform **444** to move toward the rear platform **442** when the reactive-occupant positioner moves from the pre-event configuration to the event configuration. The front and rear platforms **444, 442** may include holes to accommodate for compression of the flat springs **448, 450**.

In a sixth embodiment, the occupant support **10** includes a reactive-occupant positioner **540** including a bias unit **546** having semi-circular flat springs **548, 550**. Specifically, the bias unit **546** includes first and second semi-circular flat springs **548, 550** arranged between a front platform **544** and a rear platform **542**. A first and second end of each of the first and second flat springs **548, 550** are attached to the front platform **544** and a midpoint of each of the first and second flat springs **548, 550** is attached to the rear platform **542**. Each of the first and second flat springs **548, 550** is configured to compress inwardly to allow the front platform **544** to move toward the rear platform **542** when the reactive-occupant positioner moves from the pre-event configuration to the event configuration. The front and rear platforms **544, 542** may include holes to accommodate for compression of the semi-circular flat springs **548, 550**.

The following numbered clauses include embodiments that are contemplated and non-limiting:

Clause 1. An occupant support comprising a seat bottom and a seat back coupled to the seat bottom and arranged to extend upwardly away from the seat bottom, the seat back including a headrest located in spaced apart relation above the seat bottom and a backrest located between the headrest and the seat bottom.

Clause 2. The occupant support of clause 1, any other clause, or combination of clauses, further comprising a reactive-occupant positioner coupled to the seat back to move therewith and configured to arrange an occupant on the occupant support in response to an impact event so that the occupant moves from a pre-event arrangement, to an event arrangement, and to a post-event arrangement.

Clause 3. The occupant support of clause 2, any other clause, or combination of clauses, wherein, in the pre-event arrangement, a torso of the occupant is arranged a first distance from a frame of the seat back so that comfort is maximized prior to application of an impact force to the occupant support, in the event arrangement, the torso of the occupant is arranged a second distance from the frame that is less than the first distance so that a head of the occupant engages the headrest to minimize whiplash of the occupant during the impact event, and in the post-event arrangement, the torso of the occupant is arranged a third distance from the frame that is greater than the second distance after the impact event is complete without repair of the reactive-occupant positioner.

Clause 4. The occupant support of clause 3, any other clause, or combination of clauses, wherein, in response to the impact event, the reactive-occupant positioner changes from a pre-event configuration in which the reactive-occupant positioner causes the occupant to be in the pre-event arrangement, to an event configuration in which the reactive-occupant positioner causes the occupant to be in the event arrangement.

Clause 5. The occupant support of clause 4, any other clause, or combination of clauses, wherein the reactive-occupant positioner includes a rear platform coupled to the seat back to move therewith and a front platform movable relative to the rear platform.

Clause 6. The occupant support of clause 5, any other clause, or combination of clauses, wherein, in the pre-event configuration, the reactive-occupant positioner has a first thickness defined between the front platform and the rear platform, in the event configuration, the reactive-occupant positioner has a second thickness defined between the front platform and the rear platform that is less than the first thickness, and, in the post-event configuration, the reactive-occupant positioner has a third thickness defined between the front platform and the rear platform that is greater than the second thickness.

Clause 7. The occupant support of clause 6, any other clause, or combination of clauses, wherein the reactive-occupant positioner further includes a bias unit coupled to the front platform and to the rear platform and configured to bias the front platform away from the rear platform toward the pre-event configuration of the reactive-occupant positioner prior to application of the impact force and toward the post-impact configuration of the reactive-occupant positioner after application of the impact force to the occupant support.

Clause 8. The occupant support of clause 7, any other clause, or combination of clauses, wherein the reactive-occupant positioner further includes a first arm linkage and a second arm linkage, the first arm linkage pivotably coupled to a first top edge of the front platform and a second top edge of the rear platform, and the second arm linkage pivotably coupled to a first bottom edge of the front platform and a second bottom edge of the rear platform.

Clause 9. The occupant support of clause 8, any other clause, or combination of clauses, wherein, when the reactive-occupant positioner moves from the pre-event configuration to the event configuration, the first arm linkage and the second arm linkage pivot upwardly and toward the rear platform such that a biasing force of the bias unit increases.

Clause 10. The occupant support of clause 9, any other clause, or combination of clauses, wherein, when the reactive-occupant positioner moves from the event configuration to the post-event configuration, the first arm linkage and the second arm linkage pivot downwardly and away from the rear platform such that a biasing force of the bias unit decreases.

Clause 11. The occupant support of clause 8, any other clause, or combination of clauses, wherein the bias unit includes a first coupling member, a second coupling member, and a first biasing member, the first coupling member arranged on a first end of the first biasing member and coupled to a top portion of the front platform, and the second coupling member arranged on a second end of the first biasing member and coupled to a bottom portion of the rear platform.

Clause 12. The occupant support of clause 11, any other clause, or combination of clauses, wherein the biasing member is a spring.

Clause 13. The occupant support of clause 5, any other clause, or combination of clauses, wherein the backrest includes a backrest cushion configured to engage and support the torso of the occupant and located in spaced-apart relation to the frame, and the front platform is arranged adjacent to the backrest cushion between the rear platform.

Clause 14. The occupant support of clause 13, any other clause, or combination of clauses, wherein, in response to the impact event, the torso of the occupant pushes on

13

- the backrest cushion which in turn pushes on the front platform so as to move the front platform toward the rear platform such that the reactive-occupant positioner moves from the pre-event configuration to the post-event configuration.
- Clause 15. The occupant support of clause 3, any other clause, or combination of clauses, wherein the first distance is about equal to the third distance.
- Clause 16. The occupant support of clause 11, any other clause, or combination of clauses, wherein the bias unit further includes a third coupling member, a fourth coupling member, and a second biasing member, the third coupling member arranged on a first end of the second biasing member and coupled to the top portion of the front platform, and the fourth coupling member arranged on a second end of the second biasing member and coupled to the bottom portion of the rear platform.
- Clause 17. The occupant support of clause 16, any other clause, or combination of clauses, wherein the first arm linkage is pivotably coupled to the first top edge of the front platform via a first hinge and to the second top edge of the rear platform via a second hinge, and the second arm linkage is pivotably coupled to the first bottom edge of the front platform via a third hinge and to the second bottom edge of the rear platform via a fourth hinge.
- Clause 18. The occupant support of clause 17, any other clause, or combination of clauses, wherein the front platform includes a front main portion and the rear platform includes a rear main portion, and wherein the front main portion and the rear main portion each have a first opening configured to accommodate the first biasing member when the reactive-occupant positioner is moved to the event configuration and is in the event configuration, and a second opening configured to accommodate the second biasing member when the reactive-occupant positioner is moved to the event configuration and is in the event configuration.
- Clause 19. The occupant support of clause 18, any other clause, or combination of clauses, wherein the first arm linkage and the second arm linkage each have a third opening configured to accommodate the first biasing member when the reactive-occupant positioner is moved to the event configuration and is in the event configuration, and a fourth opening configured to accommodate the second biasing member when the reactive-occupant positioner is moved to the event configuration and is in the event configuration.
- Clause 20. The occupant support of clause 19, any other clause, or combination of clauses, wherein each of the front platform, the rear platform, the first arm linkage, and the second arm linkage includes a first opening cover and a second opening cover that are arranged to cover a majority of each of the first, second, third, and fourth openings.
- Clause 21. The occupant support of clause 20, any other clause, or combination of clauses, wherein the first coupling member and the third coupling member each include a hook member that extends through a respective portion of the third opening and the fourth opening of the first arm linkage not covered by the first and second opening covers of the first arm linkage.
- Clause 22. The occupant support of clause 21, any other clause, or combination of clauses, wherein the second coupling member and the fourth coupling member each include a hook member that extends through a respective portion of the first opening and the second opening

14

- of the rear surface platform not covered by the first and second opening covers of the rear surface platform.
- Clause 23. The occupant support of claim 22, any other clause, or combination of clauses, wherein the front platform defines a first plane and further includes a first wing and a second wing that each extend outwardly away from the front main portion of the front platform in the first plane, and the rear platform defines a second plane and further includes a third wing and a fourth wing that each extend away from the rear main portion in the second plane.
- Clause 24. The occupant support of claim 23, any other clause, or combination of clauses, wherein a transverse extent of the front platform is equal to a transverse extent of the rear platform, and wherein a transverse extent of the first arm linkage is equal to a transverse extent of the second arm linkage, and wherein the transverse extent of the front and rear platforms is greater than the transverse extent of the first and second arm linkages.
- Clause 25. The occupant support of clause 24, any other clause, or combination of clauses, wherein the second arm linkage defines a third plane and includes a first extension and a second extension that each extend outwardly away from a main portion of the second arm linkage in the third plane.
- Clause 26. The occupant support of clause 25, any other clause, or combination of clauses, wherein the second arm linkage is pivotably coupled to (i) the first bottom edge of the front platform and bottom edges of the first and second wings and (ii) the second bottom edge of the rear platform and bottom edges of the third and fourth wings via the third hinge and the fourth hinge.
- Clause 27. The occupant support of clause 26, any other clause, or combination of clauses, wherein the front platform, including the front main portion, the first wing, and the second wing, includes a top portion and a bottom portion that are coupled together via a plurality of locking mechanisms.
- Clause 28. The occupant support of clause 20, any other clause, or combination of clauses, wherein each of the first and second opening covers of the front platform is arranged to extend outwardly away from the rear platform.
- Clause 29. The occupant support of clause 20, any other clause, or combination of clauses, wherein each of the first and second opening covers of the first arm linkage is arranged to extend away from the second arm linkage.
- Clause 30. The occupant support of clause 20, any other clause, or combination of clauses, wherein each of the first and second opening covers of the rear platform is arranged to extend toward the frame away from the front platform.
- Clause 31. The occupant support of clause 17, any other clause, or combination of clauses, wherein the first and second hinges are living hinges.
- Clause 32. The occupant support of clause 7, any other clause, or combination of clauses, wherein the bias unit includes a first collapsible hinge arranged on a first side end of the front platform and a corresponding first side end of the rear platform and a second collapsible hinge arranged on a second side end of the front platform and a corresponding second side end of the rear platform, the first and second collapsible hinges configured to

15

collapse inwardly when the reactive-occupant positioner moves from the pre-event configuration to the event configuration.

Clause 33. The occupant support of clause 7, any other clause, or combination of clauses, wherein the bias unit includes first, second, and third collapsible hinges arranged on a first top edge of the front platform and a first top edge of the rear platform and fourth, fifth, and sixth collapsible hinges arranged on a first bottom edge of the front platform and a second bottom edge of the rear platform, the first, second, third, fourth, fifth, and sixth collapsible hinges configured to collapse inwardly when the reactive-occupant positioner moves from the pre-event configuration to the event configuration.

Clause 34. The occupant support of clause 7, any other clause, or combination of clauses, wherein the bias unit includes first, second, third, and fourth rectangular flat springs arranged between the front platform and the rear platform, the first, second, third, and fourth flat springs configured to compress inwardly to allow the front platform to move toward the rear platform when the reactive-occupant positioner moves from the pre-event configuration to the event configuration.

Clause 35. The occupant support of clause 7, any other clause, or combination of clauses, wherein the bias unit includes first and second semi-circular flat springs arranged between the front platform and the rear platform, wherein a first and second end of each of the first and second flat springs attached to the front platform and a midpoint of each of the first and second flat springs attached to the rear platform, and each of the first and second flat springs is configured to compress inwardly to allow the front platform to move toward the rear platform when the reactive-occupant positioner moves from the pre-event configuration to the event configuration.

The invention claimed is:

1. An occupant support comprising:
 - a seat bottom,
 - a seat back coupled to the seat bottom and arranged to extend upwardly away from the seat bottom, the seat back including a headrest and a backrest located between the headrest and the seat bottom, and
 - a reactive-occupant positioner coupled to the seat back to move therewith and configured to arrange an occupant on the occupant support in response to an impact event so that the occupant moves from:
 - a pre-event arrangement in which a torso of the occupant is arranged a first distance from a frame of the seat back,
 - to an event arrangement in which the torso of the occupant is arranged a second distance from the frame that is less than the first distance, and
 - to a post-event arrangement in which the torso of the occupant is arranged a third distance from the frame that is greater than the second distance after the impact event is complete without repair of the reactive-occupant positioner,
- wherein, in response to the impact event, the reactive-occupant positioner changes from a pre-event configuration in which the reactive-occupant positioner causes the occupant to be in the pre-event arrangement, to an event configuration in which the reactive-occupant positioner causes the occupant to be in the event arrangement,

16

wherein the reactive-occupant positioner includes a rear platform coupled to the seat back to move therewith and a front platform movable relative to the rear platform,

wherein, in the pre-event configuration, the reactive-occupant positioner has a first thickness defined between the front platform and the rear platform, in the event configuration, the reactive-occupant positioner has a second thickness defined between the front platform and the rear platform that is less than the first thickness, and, in the post-event configuration, the reactive-occupant positioner has a third thickness defined between the front platform and the rear platform that is greater than the second thickness,

wherein the reactive-occupant positioner further includes a bias unit coupled to the front platform and to the rear platform and configured to bias the front platform away from the rear platform toward the pre-event configuration of the reactive-occupant positioner prior to application of the impact force and toward the post-impact configuration of the reactive-occupant positioner after application of the impact force to the occupant support, and

wherein the reactive-occupant positioner further includes a first arm linkage and a second arm linkage, the first arm linkage pivotably coupled to a first top edge of the front platform and a second top edge of the rear platform, and the second arm linkage pivotably coupled to a first bottom edge of the front platform and a second bottom edge of the rear platform.

2. The occupant support of claim 1, wherein, when the reactive-occupant positioner moves from the pre-event configuration to the event configuration, the first arm linkage and the second arm linkage pivot upwardly and toward the rear platform such that a biasing force of the bias unit increases.

3. The occupant support of claim 2, wherein, when the reactive-occupant position moves from the event configuration to the post-event configuration, the first arm linkage and the second arm linkage pivot downwardly and away from the rear platform such that the biasing force of the bias unit decreases.

4. The occupant support of claim 1, wherein the bias unit includes a first coupling member, a second coupling member, and a first biasing member, the first coupling member arranged on a first end of the first biasing member and coupled to a top portion of the front platform, and the second coupling member arranged on a second end of the first biasing member and coupled to a bottom portion of the rear platform.

5. The occupant support of claim 4, wherein the first biasing member is a spring.

6. The occupant support of claim 4, wherein the bias unit further includes a third coupling member, a fourth coupling member, and a second biasing member, the third coupling member arranged on a first end of the second biasing member and coupled to the top portion of the front platform, and the fourth coupling member arranged on a second end of the second biasing member and coupled to the bottom portion of the rear platform.

7. The occupant support of claim 6, wherein the first arm linkage is pivotably coupled to the first top edge of the front platform via a first hinge and to the second top edge of the rear platform via a second hinge, and the second arm linkage is pivotably coupled to the first bottom edge of the front platform via a third hinge and to the second bottom edge of the rear platform via a fourth hinge.

17

8. The occupant support of claim 7, wherein the front platform includes a front main portion and the rear platform includes a rear main portion, and wherein the front main portion and the rear main portion each have a first opening configured to accommodate the first biasing member when the reactive-occupant positioner is moved to the event configuration and is in the event configuration, and a second opening configured to accommodate the second biasing member when the reactive-occupant positioner is moved to the event configuration and is in the event configuration.

9. The occupant support of claim 8, wherein the first arm linkage and the second arm linkage each have a third opening configured to accommodate the first biasing member when the reactive-occupant positioner is moved to the event configuration and is in the event configuration, and a fourth opening configured to accommodate the second biasing member when the reactive-occupant positioner is moved to the event configuration and is in the event configuration.

10. The occupant support of claim 9, wherein each of the front platform, the rear platform, the first arm linkage, and the second arm linkage includes a first opening cover and a second opening cover that are arranged to cover a majority of each of the first, second, third, and fourth openings.

11. The occupant support of claim 10, wherein the first coupling member and the third coupling member each include a hook member that extends through a respective portion of the third opening and the fourth opening of the first arm linkage not covered by the first and second opening covers of the first arm linkage, and wherein the second

18

coupling member and the fourth coupling member each include a hook member that extends through a respective portion of the first opening and the second opening of the rear surface platform not covered by the first and second opening covers of the rear surface platform.

12. The occupant support of claim 11, wherein the front platform defines a first plane and further includes a first wing and a second wing that each extend outwardly away from the front main portion of the front platform in the first plane, and the rear platform defines a second plane and further includes a third wing and a fourth wing that each extend away from the rear main portion in the second plane.

13. The occupant support of claim 1, wherein the backrest includes a backrest cushion configured to engage and support the torso of the occupant and located in spaced-apart relation to the frame, and the front platform is arranged adjacent to the backrest cushion between the rear platform and the backrest cushion.

14. The occupant support of claim 13, wherein, in response to the impact event, the torso of the occupant pushes on the backrest cushion which in turn pushes on the front platform so as to move the front platform toward the rear platform such that the reactive-occupant positioner moves from the pre-event configuration to the post-event configuration.

15. The occupant support of claim 1, wherein the first distance is about equal to the third distance.

* * * * *