

(19) World Intellectual Property Organization  
International Bureau



(43) International Publication Date  
4 November 2010 (04.11.2010)

(10) International Publication Number  
**WO 2010/126427 A1**

- (51) **International Patent Classification:**  
*H04B 10/08* (2006.01) *G01M 11/00* (2006.01)
- (21) **International Application Number:**  
PCT/SE2010/050037
- (22) **International Filing Date:**  
15 January 2010 (15.01.2010)
- (25) **Filing Language:** English
- (26) **Publication Language:** English
- (30) **Priority Data:**  
61/174,243 30 April 2009 (30.04.2009) US
- (71) **Applicant (for all designated States except US):** TELEFONAKTIEBOLAGET LM ERICSSON (publ) [SE/SE]; S-164 83 Stockholm (SE).
- (72) **Inventor; and**
- (75) **Inventor/Applicant (for US only):** DAHLFORT, Stefan [SE/SE]; Stora Rönneväg 5, 187 68 Täby (SE).
- (74) **Agent:** BERGENSTRÄHLE & LINDVALL AB; Box 17704, S-118 93 Stockholm (SE).

- (81) **Designated States (unless otherwise indicated, for every kind of national protection available):** AE, AG, AL, AM, AO, AT, AU, AZ, BA, BB, BG, BH, BR, BW, BY, BZ, CA, CH, CL, CN, CO, CR, CU, CZ, DE, DK, DM, DO, DZ, EC, EE, EG, ES, FI, GB, GD, GE, GH, GM, GT, HN, HR, HU, ID, IL, IN, IS, JP, KE, KG, KM, KN, KP, KR, KZ, LA, LC, LK, LR, LS, LT, LU, LY, MA, MD, ME, MG, MK, MN, MW, MX, MY, MZ, NA, NG, NI, NO, NZ, OM, PE, PG, PH, PL, PT, RO, RS, RU, SC, SD, SE, SG, SK, SL, SM, ST, SV, SY, TH, TJ, TM, TN, TR, TT, TZ, UA, UG, US, UZ, VC, VN, ZA, ZM, ZW.
- (84) **Designated States (unless otherwise indicated, for every kind of regional protection available):** ARIPO (BW, GH, GM, KE, LS, MW, MZ, NA, SD, SL, SZ, TZ, UG, ZM, ZW), Eurasian (AM, AZ, BY, KG, KZ, MD, RU, TJ, TM), European (AT, BE, BG, CH, CY, CZ, DE, DK, EE, ES, FI, FR, GB, GR, HR, HU, IE, IS, IT, LT, LU, LV, MC, MK, MT, NL, NO, PL, PT, RO, SE, SI, SK, SM, TR), OAPI (BF, BJ, CF, CG, CI, CM, GA, GN, GQ, GW, ML, MR, NE, SN, TD, TG).

**Published:**

— with international search report (Art. 21(3))

(54) **Title:** METHOD AND APPARATUS FOR FAULT DISCOVERY IN A PASSIVE OPTICAL NETWORK (PON)

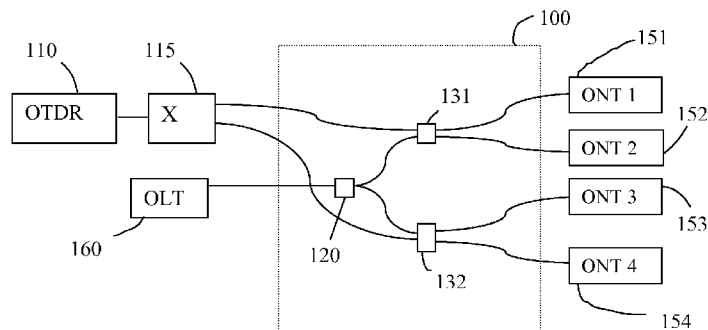

Fig. 1

(57) **Abstract:** An apparatus and method for fault indication and localization in a Passive Optical Network (PON) comprising a multistage power splitter (100, 200, 300) with at least one 1:N splitter (120, 221, 222, 321, 322) followed by N items of 2:M splitters (131, 132, 231-233, 331-336), wherein N and M are integers greater than 1. The apparatus also comprises an Optical Time Domain Reflectometry (OTDR) device (110, 210, 310) capable of inserting an OTDR signal into the power splitter (100, 200, 300), and adapted to insert the OTDR signal between the first stage of the at least one 1:N splitter (120, 221, 222, 321, 322) and the second N items of 2:M splitters (131, 132, 231-233, 331-336).

WO 2010/126427 A1

METHOD AND APPARATUS FOR FAULT DISCOVERY IN A PASSIVE  
OPTICAL NETWORK (PON).

TECHNICAL FIELD

5           The present invention relates generally to a method and an apparatus for discovering a fault in a Passive Optical Network (PON). The discovering comprises indicating, identifying and locating a fault in a PON.

10 BACKGROUND

          A Passive Optical Network (PON) is a point-to-multipoint fibre network architecture, in which unpowered (i.e. passive) optical splitters are used to enable a single optical fibre to serve multiple premises. A PON comprises at  
15 least one Optical Line Terminal (OLT) placed at the central office of the service provider and a number of Optical Network Terminations (ONT) near end users of the PON. More rarely, the OLT may be placed in an outside plant, e.g. at a street cabinet. One of the benefits of PONs is that the  
20 amount of fibre and the central office equipment required, can be reduced, as compared to point-to-point architectures. Another benefit of PONs is an anticipated much lower cost for field maintenance and fault management, as compared to metallic media networks. These costs are often referred to  
25 as "operational expenditures".

          In order to achieve the lower operational expenditures, it is important to be able to easily detect any occurring faults in the PON. A fault detection or fault indication should enable the operator of the PON to  
30 ascertain if the fault occurs in the fibre network or in the end equipment, and what kind of fault it is (i.e. identification). It is also desirable to get an indication

of what part of the fibre network and where in the fibre network the fault occurs (i.e. locating the fault).

In today's fault management solutions, Optical Time Domain Reflectometry (OTDR) is typically used. An OTDR  
5 device or OTDR instrument sends a short pulse down the fibre and detects the back reflection or back scattering from that fibre.

One important factor in optical fibre loss is the scattering of light.

10 The light is scattered in all directions in the fibre, including backwards, towards the source of light. The light that is scattered backwards towards the source of light, i.e. the back reflection or back scattering, is measured in the OTDR device or OTDR instrument. Depending on  
15 the condition of the fibre and the existence of any connectors and the like, the scattering varies as the light passes down the fibre, from having been sent out from the OTDR device/instrument. It is possible to calibrate the speed of the pulse as it passes down the fibre. By doing so,  
20 it is possible for the OTDR device/instrument to correlate what it "sees" in the back scattered or back reflected light with an actual location in the fibre. It is therefore possible to create a display of the amount of back scattered light at any point in the fibre.

25 By analysing the back scattered light, it is possible to detect any fault in the fibre, such as water intrusion, ageing, faulty connectors, splices, fibre bends, crunches on the fibre, and so on. Any such condition will affect the scattering of light.

30 The OTDR device or OTDR instrument is typically very expensive and therefore it is desirable to have as few OTDR devices as possible to perform the measurements and the

analysis. It is also desirable to perform the measurements using the OTDR device in a centrally located office, not having to bring the device or instrument into the field. However, a PON comprises one or more power splitters, which  
5 are associated with high losses. Thus, the OTDR signal is weakened after double-passing these splitters making any localisation of a fault after such a splitter very difficult. The bigger the power splitter, the bigger the loss is associated with it. A PON typically comprises power  
10 splitters with a split ratio of 1:32 or higher, making the localisation of any fault following the splitter impossible. At best, it is possible to detect a fault, but impossible to locate it.

Also, an optical power measurement at the  
15 subscriber side may be employed to detect any changes in received power, but it will not be possible to find the cause of the fault nor the location of the fault.

The ONTs may also send status messages back to the central office, in order to detect faulty fibres, optical  
20 components or faulty ONTs. However, a status message will merely indicate that a fault may have occurred, but it will not be possible to find the cause of the fault nor the location of the fault.

25

#### SUMMARY

It is an object of the invention to address at least some of the problems outlined above. In particular, it is an object of the invention to enable discovery of a fault  
30 of a fibre in a Passive Optical Network (PON).

According to one aspect, an apparatus is provided, which comprises a multistage power splitter with at least

one 1:N splitter followed by N items of 2:M splitters, wherein N and M are integers greater than 1. The apparatus further comprises an Optical Time Domain Reflectometry (OTDR) device, which is capable of inserting an OTDR signal  
5 into the power splitter. The OTDR device is adapted to insert the OTDR signal between the first stage of the at least one 1:N splitter and the second N items of 2:M splitters.

This arrangement has several advantages. One of  
10 the advantages is that the losses associated with each splitting operation can be reduced. The first splitting stage is skipped for the OTDR-signal and the losses associated therewith can be avoided. As a result, the OTDR-signal that is travelling down the fibres towards the ONTs  
15 may be stronger. Another advantage is that back reflection/scattering, indicating any possible fault(s), can be grouped together in smaller groups instead of back reflection coming to one place from all the ONTs.

According to an embodiment, the OTDR device is  
20 connected to an Optical Switch (OS) having one input connected to the output of the OTDR device and N\*K outputs connected to the inputs of the N items of 2:M splitters, wherein K is the number of Optical Line Terminals (OLT).

This has the advantage that one OTDR device can be  
25 used for identifying and localising possible faults in fibres in several different PONs, in fact in K number of PONs.

According to an embodiment, the second splitter stage is of the type 2:M, wherein  $M \leq 16$ .

30 According to another embodiment, the second splitter stage is of the type 2:M, wherein  $M = 8$ .

In one example, the power splitter is a Planar Lightwave Circuit (PLC) with integrated 2:M stages and the OTDR signal is inserted in the splitting chain so that  $M \leq 16$ .

5 In another example, the power splitter is a Planar Lightwave Circuit (PLC) with integrated 2:M stages and the OTDR signal is inserted in the splitting chain so that  $M = 8$ .

According to an embodiment, the OTDR device is  
10 connected to a Wavelength Division Multiplexor (WDM) with a tuneable or multi-wavelength OTDR.

In one example, the WDM is an Arrayed Waveguide Grating (AWG) with a maintenance wavelength window of 1625-1675 nm.

15 According to another aspect, a method is defined for detecting a fault and for locating the fault in a Passive Optical Network (PON).

The method comprises arranging/connecting an Optical Time Domain Reflectometry (OTDR) device such that it  
20 is capable of inserting an OTDR signal into a power splitter of the PON. The power splitter is a multistage stage power splitter with at least one 1:N splitter followed by N items of 2:M splitters. The method further comprises inserting an OTDR signal between the first stage of the at least one 1:N  
25 splitter and the second N items of 2:M splitters. The method also comprises analysing the scattering in order to locate any possible fault in a fibre from the power splitter and the OLT.

According to an embodiment, the method further  
30 comprises connecting the OTDR-device to an input of an optical switch having  $N \cdot K$  outputs, The outputs are connected

to the inputs of the N items of 2:M splitters, wherein K is the number of Optical Line Terminals (OLT).

According an example, the power splitter is a Planar Lightwave Circuit (PLC) with integrated 2:M stages, and the method comprises inserting the OTDR signal in the splitting chain so that  $M \leq 16$ .

According to another example, the power splitter is a Planar Lightwave Circuit (PLC) with integrated 2:M stages (231-233), and the method comprises inserting the OTDR signal in the splitting chain so that  $M = 8$ .

According to yet another embodiment, the method comprises connecting the OTDR-device to a Wavelength Division Multiplexor (WDM) with a tuneable or multi-wavelength OTDR.

15

#### BRIEF DESCRIPTION OF THE DRAWINGS

The invention will now be described in more detail by means of exemplary embodiments and with reference to the accompanying drawings, in which:

- Fig. 1 is a schematic view of a two stage 1:4 splitter with the OTDR device connected according to an embodiment.
- Fig. 2 is a schematic view of a Planar Lightwave Circuit with the OTDR device connected according to an embodiment.
- Fig. 3 is a schematic view of a number of K Optical Line Terminals (OLTs), an Optical Switch (OS), a two stage splitter and a number of  $N \cdot M \cdot K$  Optical Network Terminations (ONTs) with the OTDR-device connected according to an embodiment.

30

- Fig. 4 is a flowchart of a method according to an embodiment.
- Fig. 5 is a flowchart of a method according to another embodiment.

5

## DETAILED DESCRIPTION

Briefly described, an apparatus and a method are provided for discovering a fault in a Passive Optical  
10 Network (PON).

As described above, OTDR signals are often used to detect faults in a fibre network. Also, the Optical Network Terminations (ONTs) may measure signal strengths and report these measurements back to a central office.

15 Below, an arrangement and a method for discovering a fault in a PON will be described. The discovering of a fault entails indicating that a fault has occurred and where on the fibre the fault has occurred, i.e. to locate the fault.

20 An example of how an apparatus may be realised or implemented will now be described with reference to figures 1, 2 and 3.

Figure 1 is a schematic view of a two stage 1:4 splitter with the OTDR-device connected according to an  
25 embodiment.

Figure 1 shows an example of an arrangement for fault discovery in a Passive Optical Network (PON). The arrangement comprises a two stage power splitter 100 with one 1:2 splitter 120 followed by 2 items of 2:2 splitters  
30 131, 132. The arrangement also comprises an Optical Time Domain Reflectometry (OTDR) device 110 that is capable of inserting an OTDR signal into the power splitter 100. A

switching arrangement 115 is provided between the OTDR device or instrument 110 and the power splitter 100. The OTDR device 110 is adapted to insert the OTDR signal between the first stage of the 1:2 splitter 120 and the second stage of two items of 2:2 splitters 131, 132. Further, there are four Optical Network Terminations (ONTs) 151, 152, 153 and 154. Figure 1 also shows one Optical Line Terminal (OLT) 160. The OLT 160 is typically located at a central office of the service provider. The ONTs are arranged at locations near end users of the PON.

One of the advantages of arranging the OTDR device 110 such that it is capable of inserting an OTDR signal into the power splitter between the first and second splitting stage, is that the losses associated with each splitting operation can be reduced. The first splitting stage is skipped for the OTDR signal and the losses associated therewith can be avoided. As a result, the OTDR signal that is travelling down the fibres towards the ONTs will most likely be stronger. Another advantage is that back reflection/scattering, indicating any possible fault(s), can be grouped together in smaller groups instead of having back reflection supplied to one place from all the ONTs.

To clarify, instead of receiving all back reflection from all ONTs 151-154 in one bunch at the OTDR device 110 going through the whole power splitter on its way back, back reflection from ONTs 151 and 152 can be grouped together, and the back reflection from ONTs 153 and 154 can be grouped together. "Grouped together" means that the back reflection that is detected is the sum of the back reflection from ONTs 151 plus 152 in one group and back reflection from ONTs 153 plus 154 in one group. It is generally easier to extract and analyse information from a

smaller group than from a larger group, which can be utilised in this solution. In this way, back reflection from the ONTs 151 and 152 may be analysed separately and back reflection from ONTs 153 and 154 may be analysed separately.

5           Also, the back reflection does not have to travel all the way through the power splitter 100, which can reduce losses associated with every splitting operation. In figure 1, the splitter 120 can be avoided, i.e. the first splitting stage. Since the back reflection may be both stronger from  
10 not having to pass through the whole power splitter, i.e. both the first and the second splitting stage, and since the back reflection from different ONTs are grouped together, more information can be extracted from the received back reflection. In this way, a fault can not only be identified  
15 and indicated more easily, but it can also be possible to locate where along the fibre the fault is located or has occurred.

          Quite often, splitters of 1:32 are used comprising a first splitting stage of split 1:4 and a second splitting  
20 stage of split 2:8. The higher the split ratio, the more difficult it becomes to analyse and extract information from the back reflection or the scattering. The advantages of the invention becomes more evident the higher the split.

          For splits higher than 2:16, it is difficult for  
25 today's OTDR devices to extract enough information as to determine the location of a fault along a fibre, due to the losses and the high number of ONTs that are grouped together. In such a split, back reflection from 16 ONTs are grouped together. For higher splits, it is possible to  
30 detect and indicate that a fault has occurred and it may be possible to indicate which fibre is faulty, but it may become difficult to ascertain exactly where the fault has

occurred. Therefore, it may be preferable that the last splitter stage is of the type 2:M, where  $M \leq 16$ .

According to one embodiment, the last splitter stage is of the type 2:M, where  $M = 8$ .

5           The splitter 100 that is shown in figure 1 can be an ordinary two stage splitter, wherein the OTDR signal is inserted between the first and the second stage. The splitter 100 in figure 1 can also be a Planar Lightwave Circuit (PLC) with integrated 2:2 stages.

10           By OTDR measurements it is meant measuring the back reflection or back scattering that occurs when an OTDR signal is sent down the fibres in the PON. As can be seen in figure 1, splitters 131 and 132 are 2:2 splitters. One input of each splitter 131 and 132 comes from the respective two  
15           outputs of splitter 120. The other input of each respective splitter 131 and 132 is connected to the OTDR device.

          Figure 2 is a schematic view of a Planar Lightwave Circuit (PLC) with the OTDR device connected according to an embodiment of the arrangement. In a PLC, there are a number  
20           of cascade arranged splitters. It should be noted that figure 2 is merely schematic and some of the splitters in the PLC have been left out for simplicity. Moreover, it should be noted that PLC is not the only splitter technology that could be employed, although dominating today. This  
25           arrangement can be implemented with any type of splitter technology.

          Figure 2 shows an OTDR device 210 arranged to insert an OTDR signal into a power splitter 200, in this case a PLC 200. The OTDR-device 210 is adapted to insert the  
30           OTDR signal between the first stage of the 1:N splitters and the second 2:M splitters. Figure 2 shows a PLC with cascade splitters 221, 222, 231, 232 and 233 of splits 2:2. In

figure 2, only splitter 231 makes use of its two inputs, as one input is connected to the output of splitter 222 that is arranged before splitter 231 in the cascade. The other input of splitter 231 is connected to the OTDR device 210. The  
5 other shown splitters 221, 222, 232 and 233 make use of one input only. The first splitter 221 in the cascade has one input connected to an OLT 260 and splits the input in two. In figure 2, splitters 221 and 222 constitute a first splitting stage, here as a split 1:4. The splitters 231, 232  
10 and 233 constitute a second splitting stage, here as a split 2:8. The whole PLC 200 consequently splits 1:32.

Figure 2 also shows the OTDR being connected to an Optical Switch 270. This variant is optional and may be used in case the PON has a plurality of OLTs, each OLT being  
15 connected to a respective power splitter. This will be described in more detail below with reference to figure 3.

Figure 3 is a schematic view of a number of K Optical Line Terminals (OLTs), an Optical Switch (OS), K number of two-stage-power-splitters and a number of  $N \cdot M \cdot K$   
20 Optical Network Terminations (ONTs) with the OTDR-device connected according to an embodiment of the arrangement.

In figure 3, K number of two-stage-power-splitters are shown. It shall be noted that figure 3 is a schematic representation where some parts of the number of K power  
25 splitters have been left out for simplicity reasons. Also, figure 3 may give the impression that the K power splitters and stages are arranged at the same location, although this is not necessarily the case.

There are K number of OLTs 361, 362 each being  
30 connected to a respective power splitter. Each power splitter comprises a first stage of a 1:N splitter 321, 322 and N number or items of 2:M splitters 331-336. Figure 3

also shows  $N \times M \times K$  number of ONTs 351-354 connected to the  $K$  number of power splitters.

Figure 3 also shows an OTDR-device 310 connected to the  $K$  number of power splitters via an Optical Switch (OS) 370, optionally also via a filter 380. The OS 370 has one input and  $N \times K$  number of outputs corresponding to the total number of  $N \times K$  2:M splitters 331-336. The OTDR signal is inserted in the OS 370, which transmits the signal further via its  $N \times K$  number of outputs. The outputs of the OS 370 are each connected to one of the two inputs of each of the second stage 2:M splitters 331-336 respectively. The other input of the two inputs of each of the second stage 2:M splitters 331-336 is connected to one of the outputs of the first stage 1:N splitters 321 and 322 respectively.

Figure 3 also shows a filter 380 arranged between the OTDR device or instrument and the Optical Switch (OS).

Like described above, the OTDR device 310 is arranged to insert an OTDR signal between the first and second splitting stage of each and every one of the  $K$  number of power splitters.

Assume that  $N=4$ ,  $M=8$  which results in 32 ONTs per PON, wherein each PON has one OLT. Assume that  $K=128$ . This means that one OTDR instrument or device may be used for 4096 ONTs, corresponding to 128 different PONs.

Increasing values of  $M$  will result in more ONTs being, so to speak, grouped together, meaning that the back reflection or back scattering of light that is received at the OTDR-instrument or device will be the sum of the back reflection of  $M$  number of ONTs. This will require a more advanced and hence a more expensive OTDR instrument as the OTDR monitoring will become more difficult with increasing values of  $M$ . On the other hand, a high value of  $M$  will

reduce the overall cost of sharing OTDRs, feeder fibres and optical switches.

The Optical Switch (OS) may be a mechanical switch. It should preferably not have any active equipment. However, in future long-reach PON applications, this might not necessarily be the case. Preferably, the OS is remotely powered and latching. Latching typically should only require power when changing output port. Various solutions are available for using the feeder fibre for a wavelength carrying power. This wavelength may require filters on both sides of the OTDR feeder fibre not to interfere with the OTDR signal, see for example figure 3, showing a filter 380. Also, optical filters on both ends of the OLT to splitter fibre may be used to transmit the OTDR signal, e.g. avoiding a dedicated fibre for this purpose.

According to an example of the arrangement, the OTDR device is connected to a Wavelength Division Multiplexor (WDM) with a tuneable or multi-wavelength OTDR. This is an alternative to using an OS as shown in figures 2 and 3. In other words, the OS in figures 2 and 3 may be replaced by a WDM.

An example of a WDM is an Arrayed Waveguide Grating (AWG) with a pass-band spectrum in the maintenance wavelength window of 1625-1675 nm.

Some examples of a method for discovering a fault and for locating the fault in a Passive Optical Network (PON), will now be described with reference to figures 4 and 5 respectively. The method entails the same advantages as the arrangement already described above.

Figure 4 shows a flowchart of a method comprising a step 410 of arranging/connecting an Optical Time Domain Reflectometry (OTDR) device such that it is capable of

inserting an OTDR signal into a power splitter of the PON. The power splitter is a multistage stage power splitter with at least one 1:N splitter followed by N items of 2:M splitters. The method further comprises a step 420 of  
5 inserting an OTDR signal between the first stage of the at least one 1:N splitter and the second N items of 2:M splitters. Further, the method comprises a step 430 of analysing the back reflection/scattering in order to locate any possible fault in a fibre from the power splitter and  
10 the ONT.

Figure 5 shows another example of the method comprising a step 511 of arranging/connecting an Optical Time Domain Reflectometry (OTDR) device such that it is capable of inserting an OTDR signal into a power splitter of  
15 the PON. The power splitter is a multistage stage power splitter with at least one 1:N splitter followed by N items of 2:M splitters. The method further comprises a step 512 of connecting the OTDR device to an input of an optical switch having N\*K outputs connected to the inputs of the N  
20 items of 2:M splitters, wherein K is the number of Optical Line Terminals (OLT). The method also comprises a step 520 of inserting an OTDR signal between the first stage of the at least one 1:N splitter and the second N items of 2:M splitters.

25 The back reflection/scattering is analysed in a step 530, in order to locate any possible fault in a fibre from the power splitter and the ONT.

In a case when the power splitter is a Planar Lightwave Circuit with integrated 2:M stages, an embodiment  
30 of the method comprises inserting the OTDR signal in the splitting chain so that  $M \leq 16$ .

In a case when the power splitter is a Planar Lightwave Circuit with integrated 2:M stages, another embodiment of the method comprises inserting the OTDR signal in the splitting chain so that  $M = 8$ .

5            Yet another example of the method entails connecting the OTDR-device to a Wavelength Division Multiplexor (WDM) with a tuneable or multi-wavelength OTDR.

10           While the invention has been described with reference to specific exemplary embodiments, the description is generally only intended to illustrate the inventive concept and should not be taken as limiting the scope of the invention. The invention is defined by the appended claims.

## CLAIMS

1. An arrangement for fault discovery in a Passive Optical Network (PON), comprising
  - 5 - a multistage power splitter (100, 200, 300) with at least one 1:N splitter (120, 221, 222, 321, 322) followed by N items of 2:M splitters (131, 132, 231-233, 331-336), wherein N and M are integers greater than 1, and
  - an Optical Time Domain Reflectometry (OTDR) device  
10 (110, 210, 310) capable of inserting an OTDR signal into the power splitter (100, 200, 300), and adapted to insert the OTDR signal between the first stage of the at least one 1:N splitter (120, 221, 222, 321, 322) and the second N items of 2:M splitters (131, 132, 231-233, 331-336).  
15
2. An arrangement according to claim 1, wherein the OTDR device (110, 210, 310) is connected to an Optical Switch (OS) (270, 370) having one input connected to the output of the OTDR device (110, 210, 310) and N\*K outputs  
20 connected to the inputs of the N items of 2:M splitters (131, 132, 231-233, 331-336), wherein K is the number of Optical Line Terminals (OLT) (160, 260, 361, 362).
3. An arrangement as in claim 1 or 2, wherein the second  
25 splitter stage is of the type 2:M, wherein  $M \leq 16$ .
4. An arrangement as in claim 1 or 2, wherein the second splitter stage is of the type 2:M, wherein  $M = 8$ .
- 30 5. An arrangement as in claim 1, wherein the power splitter (200) is a Planar Lightwave Circuit (PLC) with integrated 2:M stages (231-233) and the OTDR signal is inserted in the splitting chain so that  $M \leq 16$ .

6. An arrangement as in claim 1, wherein the power splitter (200) is a Planar Lightwave Circuit (PLC) with integrated 2:M stages (231-233) and the OTDR signal is inserted in the splitting chain so that  $M = 8$ .
7. An arrangement as in claim 1, wherein the OTDR device is connected to a Wavelength Division Multiplexor (WDM) having one input connected to the output of the OTDR device (110, 210, 310) and  $N \cdot K$  outputs connected to the inputs of the  $N$  items of 2:M splitters (131, 132, 231-233, 331-336), wherein  $K$  is the number of Optical Line Terminals (OLT) (160, 260, 361, 362), wherein the WDM has a tuneable or multi-wavelength OTDR.
8. An arrangement according to claim 7, wherein the WDM is an Arrayed Waveguide Grating (AWG) with a maintenance wavelength window of 1625-1675 nm.
9. A method of discovering a fault in a Passive Optical Network (PON), comprising
- arranging/connecting an Optical Time Domain Reflectometry (OTDR) device such that it is capable of inserting an OTDR signal into a power splitter of the PON, wherein the power splitter is a multistage stage power splitter with at least one 1:N splitter followed by  $N$  items of 2:M splitters,
  - inserting an OTDR signal between the first stage of the at least one 1:N splitter and the second  $N$  items of 2:M splitters, and

- analysing the scattering in order to locate any possible fault in a fibre from the power splitter and the OLT.

5 10. A method according to claim 9, further comprising connecting said OTDR-device (110, 210, 310) to an input of an optical switch (270, 370) having  $N \cdot K$  outputs connected to the inputs of the  $N$  items of 2:M splitters (131, 132, 231-233, 331-336), wherein  $K$  is the number of  
10 Optical Line Terminals (OLT) (160, 260, 361, 362).

11. A method according to claim 9 or 10, wherein the power splitter (200) is a Planar Lightwave Circuit (PLC) with integrated 2:M stages (231-233), the method comprises  
15 inserting the OTDR signal in the splitting chain so that  $M \leq 16$ .

12. A method according to claim 9 or 10, wherein the power splitter (200) is a Planar Lightwave Circuit (PLC) with  
20 integrated 2:M stages (231-233), the method comprises inserting the OTDR signal in the splitting chain so that  $M = 8$ .

13. A method according to claim 9, comprising connecting the  
25 OTDR-device to a Wavelength Division Multiplexor (WDM) with a tuneable or multi-wavelength OTDR, the WDM having one input connected to the output of the OTDR device (110, 210, 310) and  $N \cdot K$  outputs connected to the inputs of the  $N$  items of 2:M splitters (131, 132, 231-233, 331-  
30 336), wherein  $K$  is the number of Optical Line Terminals (OLT) (160, 260, 361, 362).

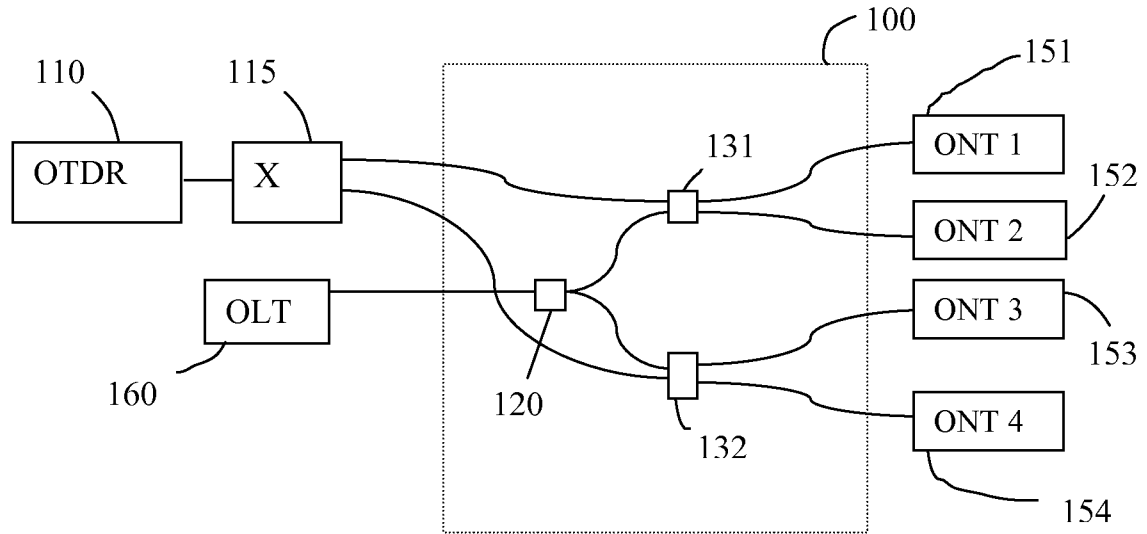

Fig. 1

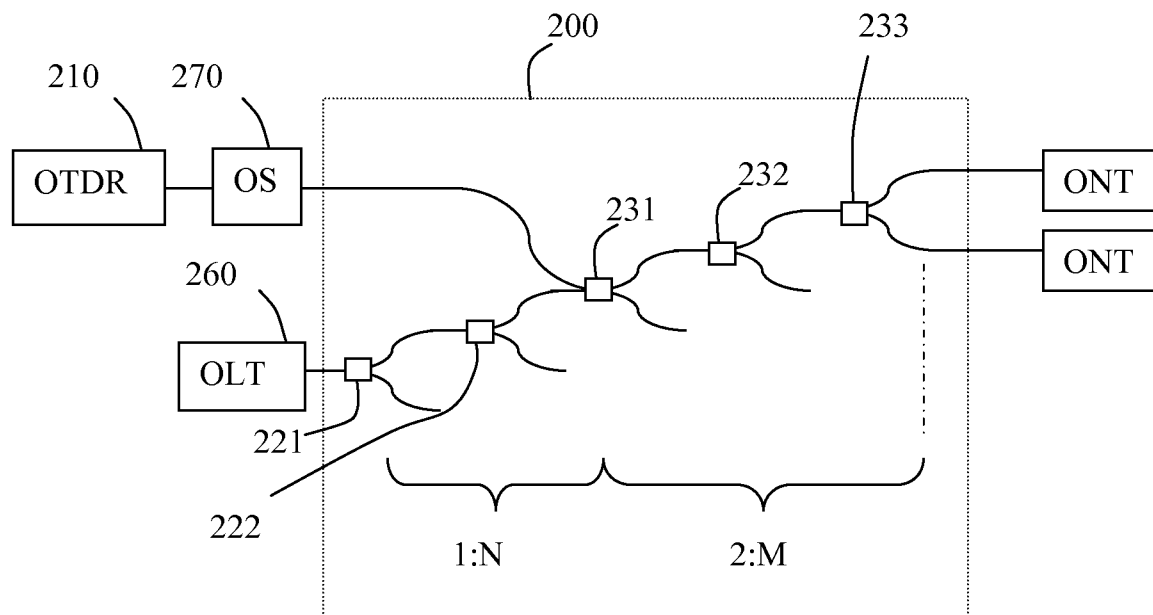

Fig. 2

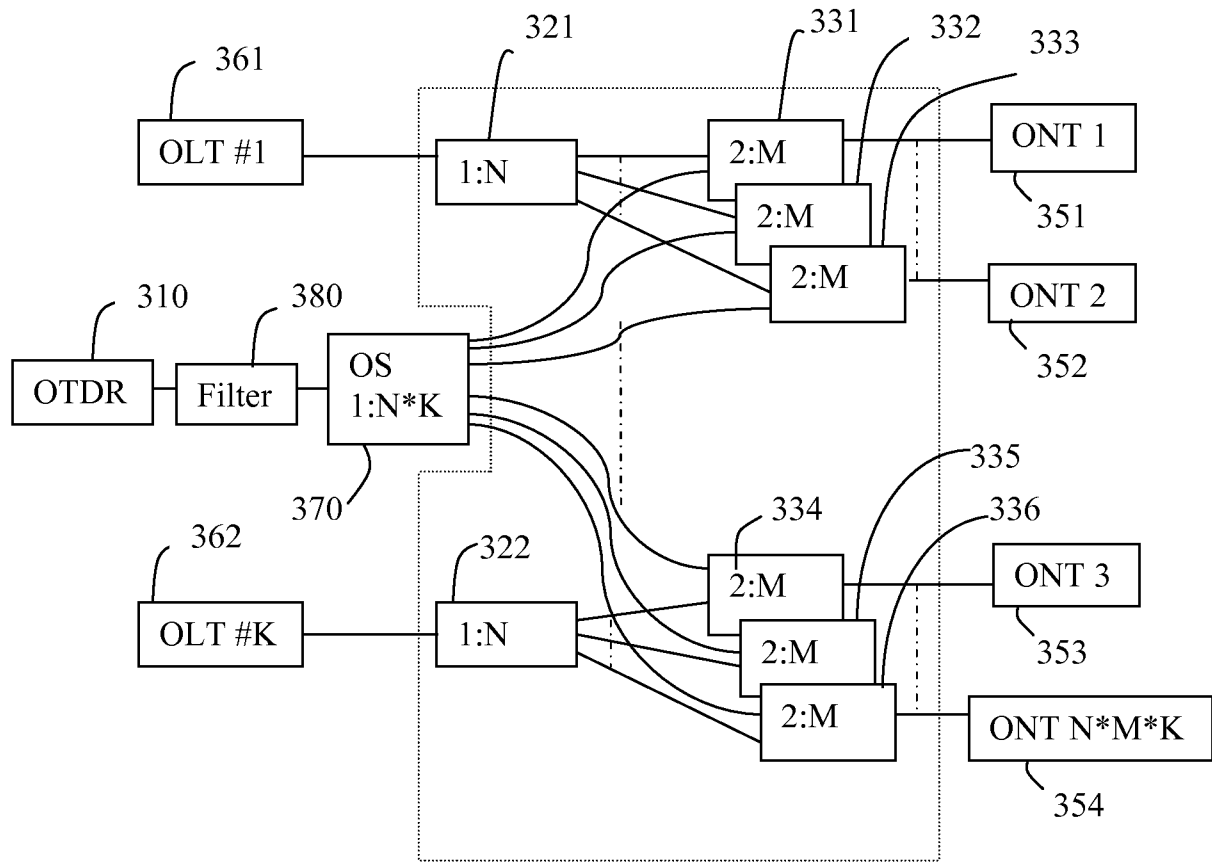

Fig. 3

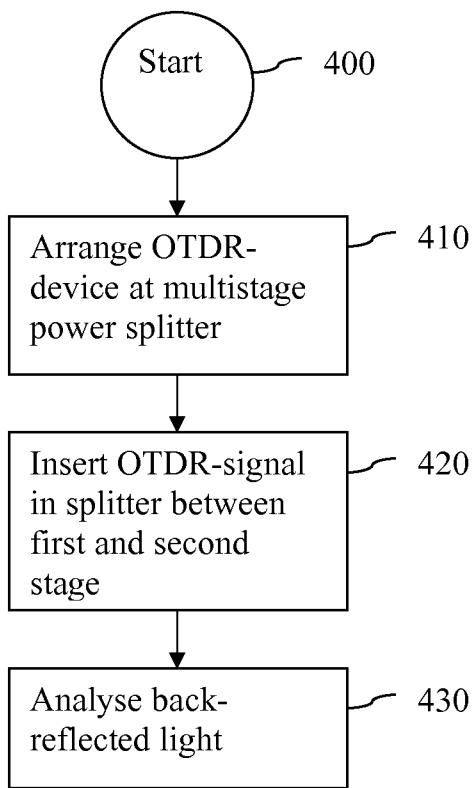

Fig. 4

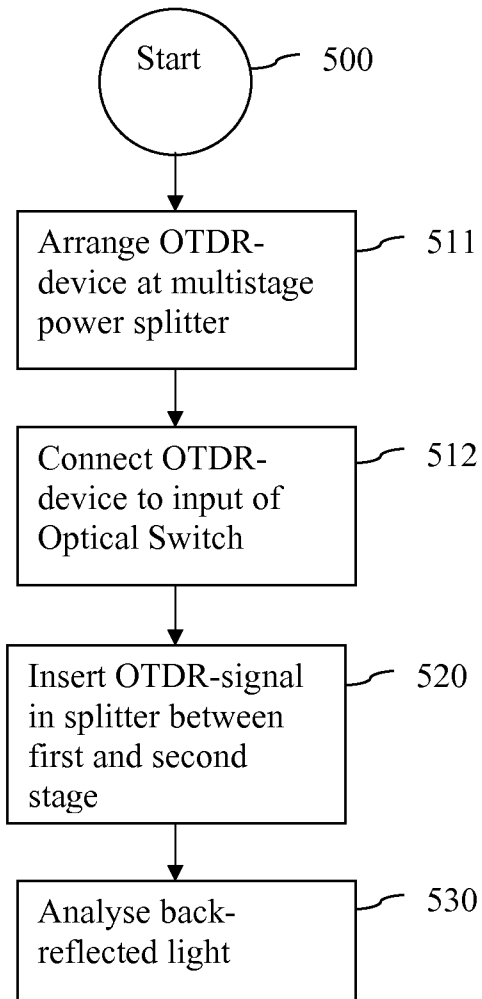

Fig. 5

## INTERNATIONAL SEARCH REPORT

International application No.  
PCT/SE2010/050037

## A. CLASSIFICATION OF SUBJECT MATTER

IPC: see extra sheet

According to International Patent Classification (IPC) or to both national classification and IPC

## B. FIELDS SEARCHED

Minimum documentation searched (classification system followed by classification symbols)

IPC:G01M, H04B

Documentation searched other than minimum documentation to the extent that such documents are included in the fields searched

SE, DK, FI, NO classes as above

Electronic data base consulted during the international search (name of data base and, where practicable, search terms used)

EPO-Internal, PAJ, WPI data, INSPEC, IBM-TDB

## C. DOCUMENTS CONSIDERED TO BE RELEVANT

Category*	Citation of document, with indication, where appropriate, of the relevant passages	Relevant to claim No.
X	US 20080031624 A1 (SMITH JOSEPH LEE ET AL), 7 February 2008 (2008-02-07); paragraphs [0010]-[0011], [0013], [0019], [0023]; figures 2,3	1-13
	--	
A	EP 0546707 A2 (AMERICAN TELEPHONE & TELEGRAPH), 16 June 1993 (1993-06-16); abstract	1-13
	--	
A	EP 1980834 A1 (FUJIKURA LTD), 15 October 2008 (2008-10-15); paragraph [0081]	5, 11, 12
	--	
A	US 20060110161 A1 (CHO YUN H ET AL), 25 May 2006 (2006-05-25); paragraph [0019]; figure 2	7, 8, 13
	--	
E	WO 2010010378 A1 (TYCO ELECTRONICS RAYCHEM BVBA ET AL), 28 January 2010 (2010-01-28)	1-13
	--	
	-----	

 Further documents are listed in the continuation of Box C. See patent family annex.

\* Special categories of cited documents:

"A" document defining the general state of the art which is not considered to be of particular relevance

"E" earlier application or patent but published on or after the international filing date

"L" document which may throw doubts on priority claim(s) or which is cited to establish the publication date of another citation or other special reason (as specified)

"O" document referring to an oral disclosure, use, exhibition or other means

"P" document published prior to the international filing date but later than the priority date claimed

"T" later document published after the international filing date or priority date and not in conflict with the application but cited to understand the principle or theory underlying the invention

"X" document of particular relevance; the claimed invention cannot be considered novel or cannot be considered to involve an inventive step when the document is taken alone

"Y" document of particular relevance; the claimed invention cannot be considered to involve an inventive step when the document is combined with one or more other such documents, such combination being obvious to a person skilled in the art

"&amp;" document member of the same patent family

Date of the actual completion of the international search

30-07-2010

Date of mailing of the international search report

02-08-2010

Name and mailing address of the ISA/SE

Patent- och registreringsverket  
Box 5055  
S-102 42 STOCKHOLM  
Facsimile No. + 46 8 666 02 86

Authorized officer

Erik Westin

Telephone No. + 46 8 782 25 00

**Continuation of:** second sheet

**International Patent Classification (IPC)**

**H04B 10/08** (2006.01)

**G01M 11/00** (2006.01)

**Download your patent documents at [www.prv.se](http://www.prv.se)**

The cited patent documents can be downloaded:

- From "Cited documents" found under our online services at [www.prv.se](http://www.prv.se)  
(English version)
- From "Anförda dokument" found under "e-tjänster" at [www.prv.se](http://www.prv.se)  
(Swedish version)

Use the application number as username. The password is **ZBXMQIXTMS**.

Paper copies can be ordered at a cost of 50 SEK per copy from PRV InterPat (telephone number 08-782 28 85).

Cited literature, if any, will be enclosed in paper form.

## INTERNATIONAL SEARCH REPORT

Information on patent family members

International application No.

PCT/SE2010/050037

US	20080031624	A1	07/02/2008	US	7715718	B2	11/05/2010
EP	0546707	A2	16/06/1993	DE	69222273	T2	15/01/1998
				DE	69230920	T2	19/07/2001
				JP	7303266	A	14/11/1995
				JP	2695586	B2	24/12/1997
				US	RE36471	E	28/12/1999
EP	1980834	A1	15/10/2008	US	20090190921	A1	30/07/2009
				WO	2007088976	A1	09/08/2007
US	20060110161	A1	25/05/2006	KR	100687710	B1	27/02/2007
				KR	20060056454	A	24/05/2006
WO	2010010378	A1	28/01/2010	NONE			