



US009130409B2

(12) **United States Patent**
Moh

(10) **Patent No.:** **US 9,130,409 B2**
(45) **Date of Patent:** **Sep. 8, 2015**

(54) **WIRELESS ENERGY RECEIVER/TRANSMITTER/SYSTEM AND WIRELESS ENERGY TRANSMISSION METHOD**

(58) **Field of Classification Search**
USPC 307/104
See application file for complete search history.

(71) Applicant: **Kyung Goo Moh**, Yongin-Si (KR)

(56) **References Cited**

(72) Inventor: **Kyung Goo Moh**, Yongin-Si (KR)

U.S. PATENT DOCUMENTS

(73) Assignee: **Samsung Electronics Co., Ltd.**,
Suwon-si, Gyeonggi-do (KR)

7,375,596 B2 5/2008 Park et al.
7,741,734 B2 6/2010 Joannopoulos et al.
2008/0211320 A1 9/2008 Cook et al.
2009/0284220 A1 11/2009 Toncich et al.

(*) Notice: Subject to any disclaimer, the term of this patent is extended or adjusted under 35 U.S.C. 154(b) by 482 days.

FOREIGN PATENT DOCUMENTS

(21) Appl. No.: **13/677,453**

KR 20060091192 A 8/2006

(22) Filed: **Nov. 15, 2012**

Primary Examiner — Robert Deberadinis

(65) **Prior Publication Data**

US 2013/0127258 A1 May 23, 2013

(74) *Attorney, Agent, or Firm* — Volentine & Whitt, PLLC

(30) **Foreign Application Priority Data**

Nov. 17, 2011 (KR) 10-2011-0120520

(57) **ABSTRACT**

(51) **Int. Cl.**
H02J 17/00 (2006.01)
H02J 5/00 (2006.01)
H03J 3/20 (2006.01)
H01F 27/42 (2006.01)

A wireless energy transmission system includes a wireless energy transmitting device and a wireless energy receiving device configured to receive power from the wireless energy transmitting device through a magnetic field. The wireless energy transmitting device includes a signal generator configured to include a resonator including at least one inductor and at least one capacitor and to generate at least two signals having a 90-degree phase difference from each other. The wireless energy receiving device includes a frequency adjustor configured to match a frequency between the wireless energy transmitting device and the wireless energy receiving device.

(52) **U.S. Cl.**
CPC **H02J 17/00** (2013.01); **H02J 5/005** (2013.01); **H03J 3/20** (2013.01)

20 Claims, 19 Drawing Sheets

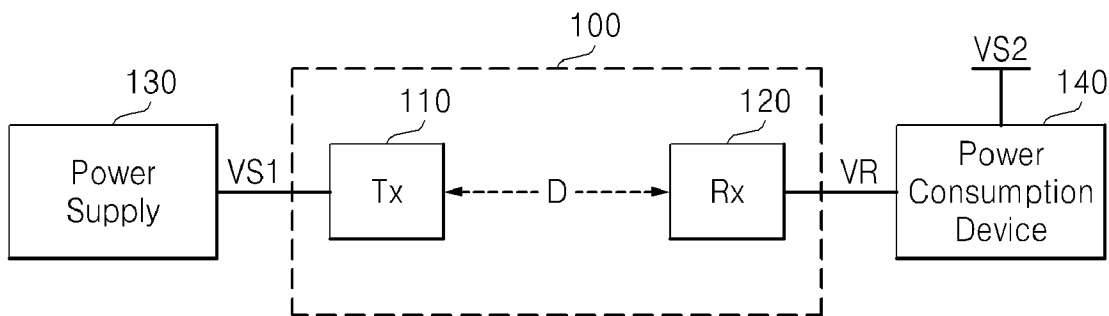

FIG. 1

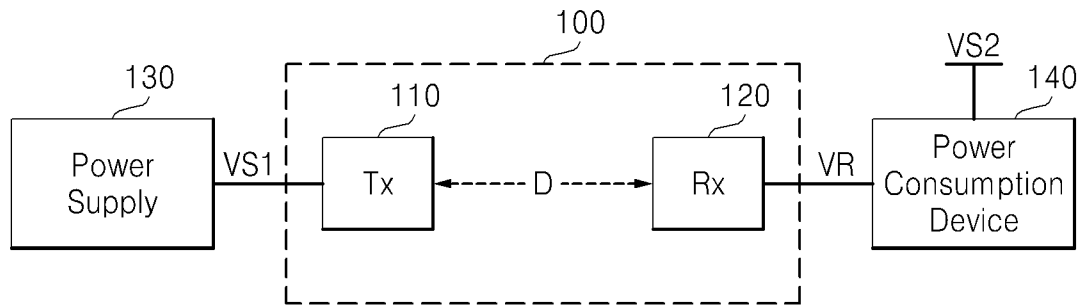

FIG. 2

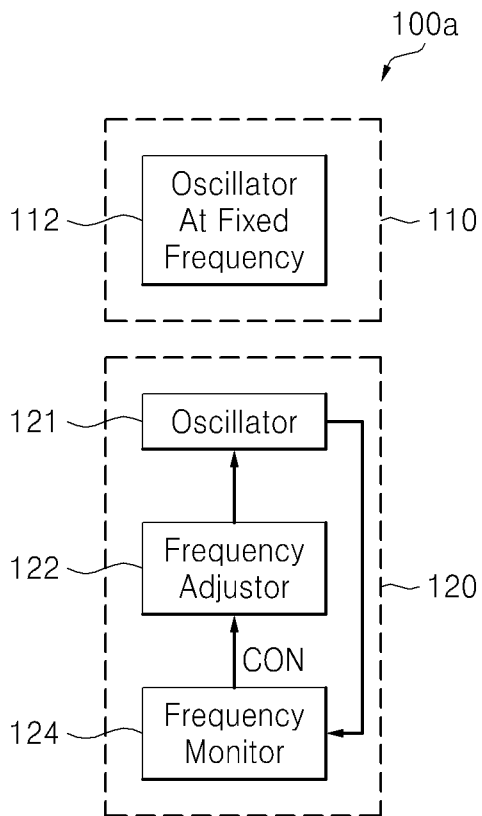

FIG. 3

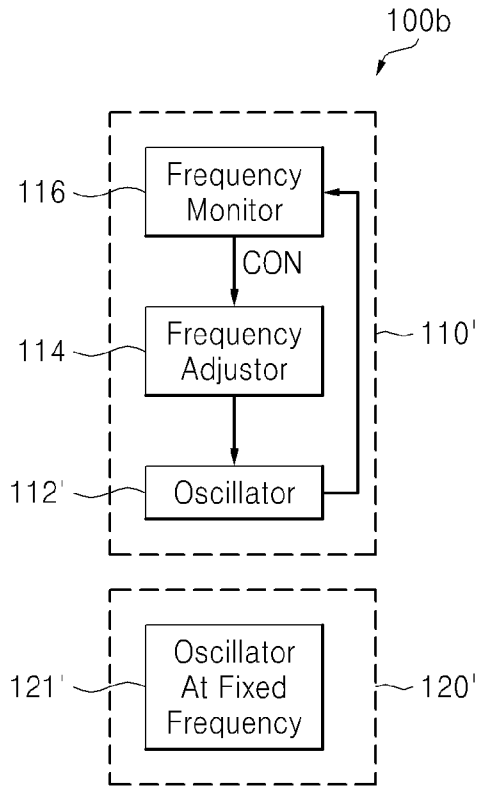
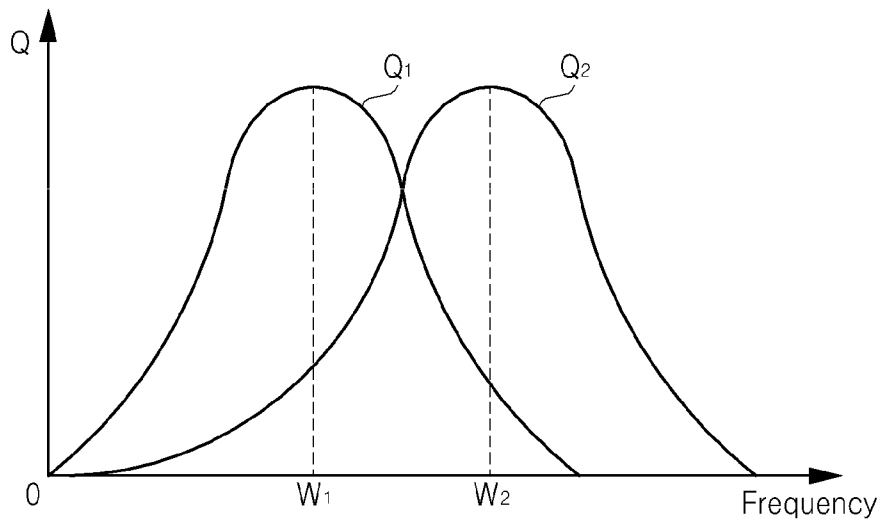

FIG. 4



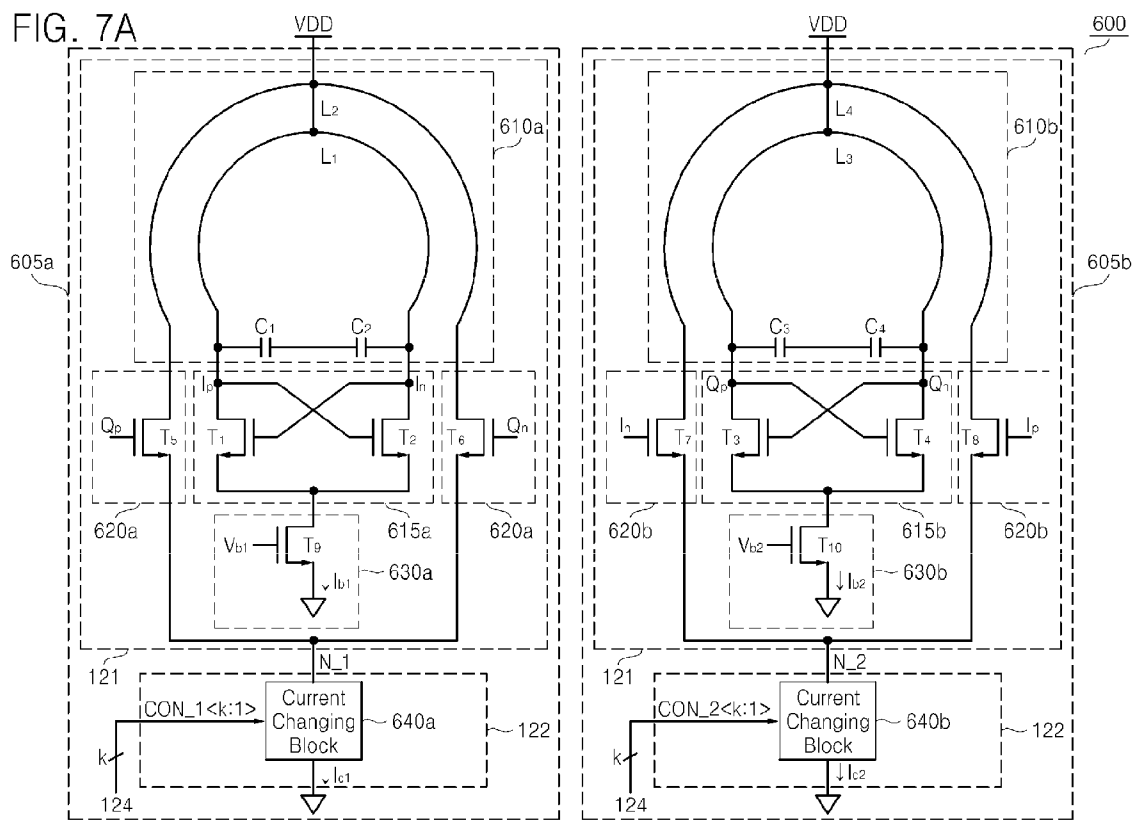

FIG. 7B

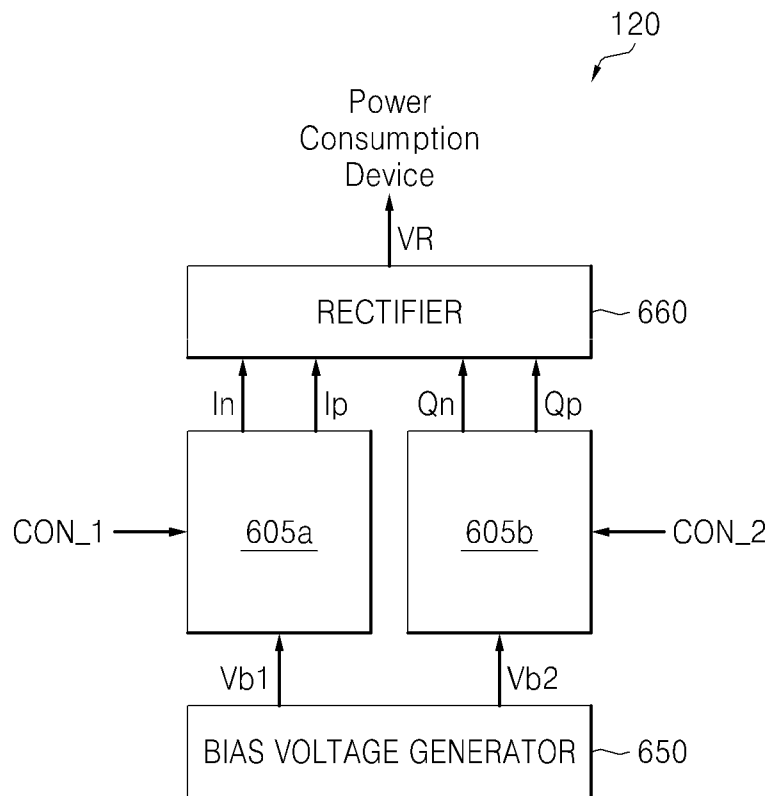

FIG. 8

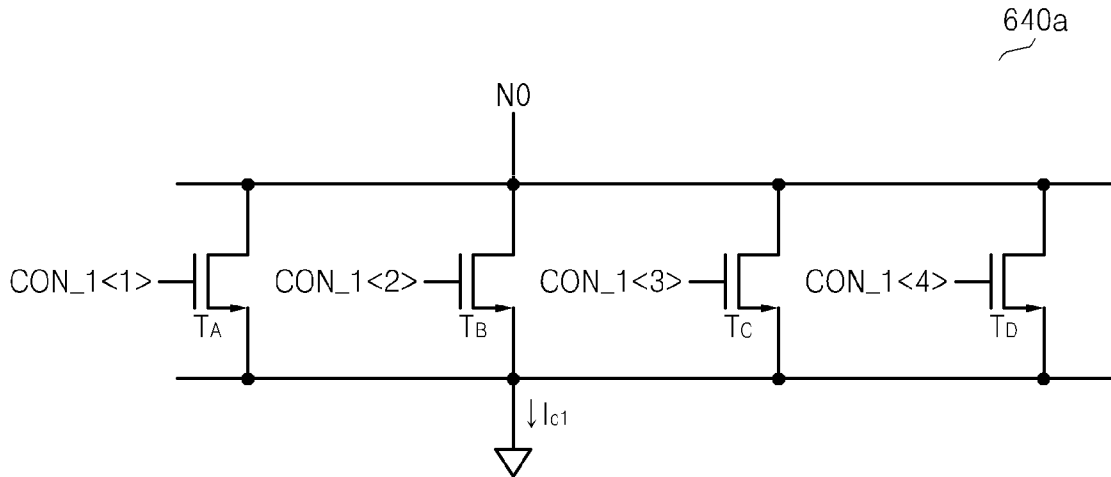

FIG. 9

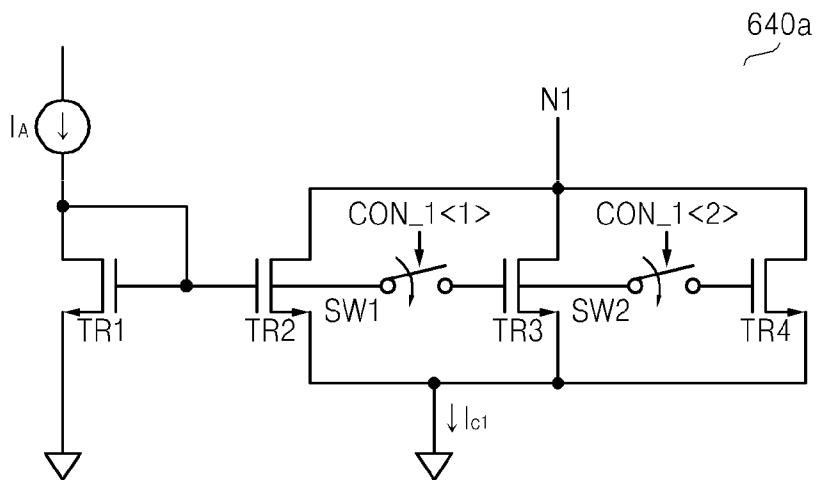

FIG. 10

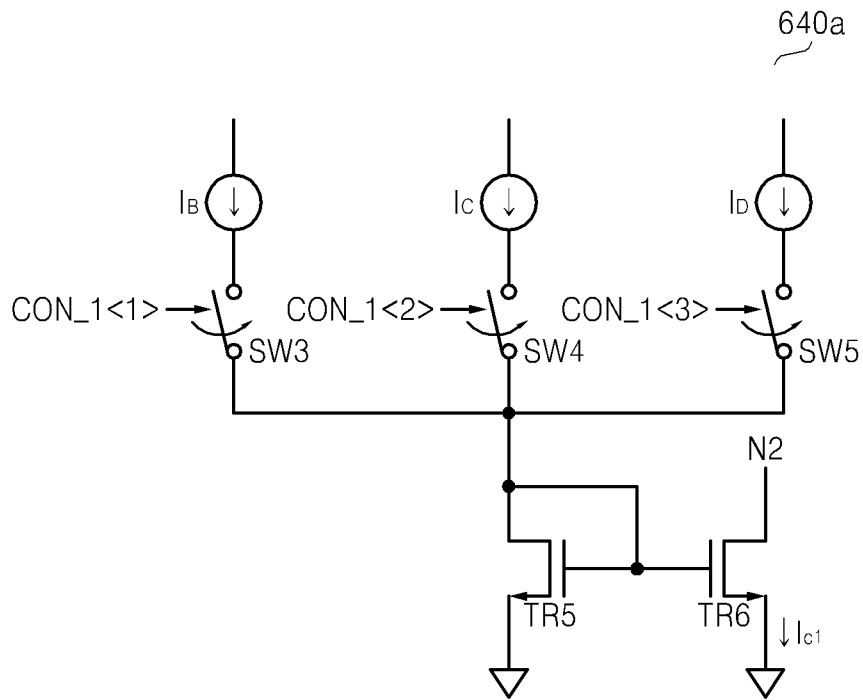

FIG. 11

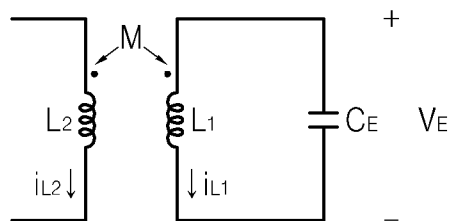

FIG. 12

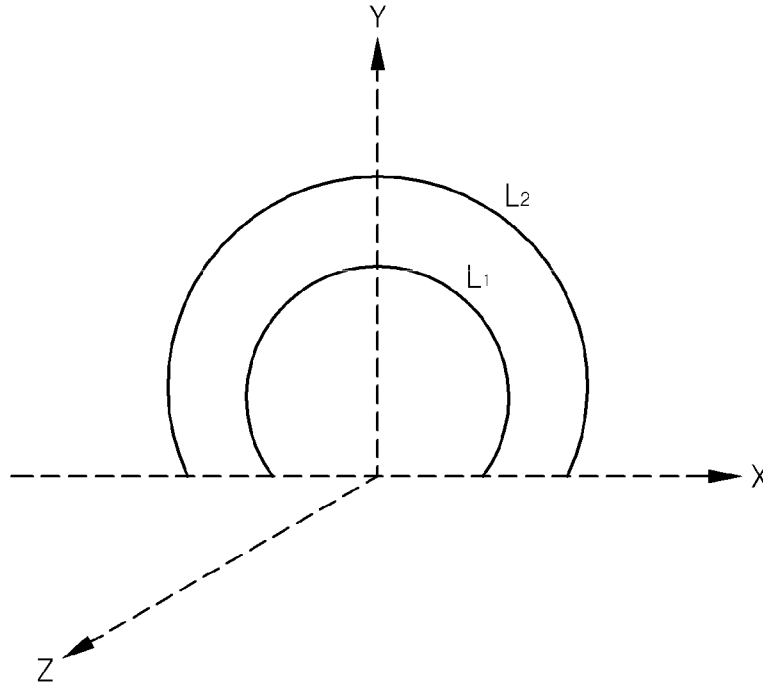

FIG. 13

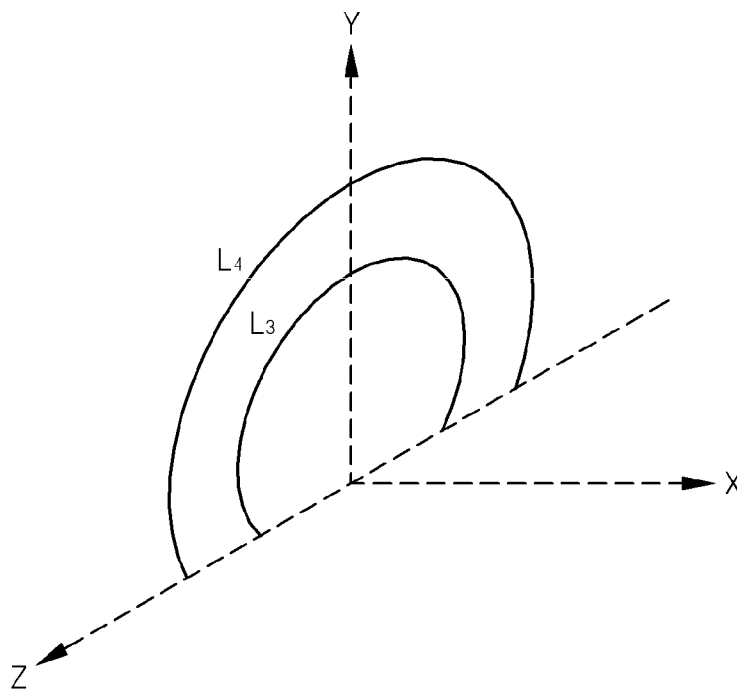

FIG. 14

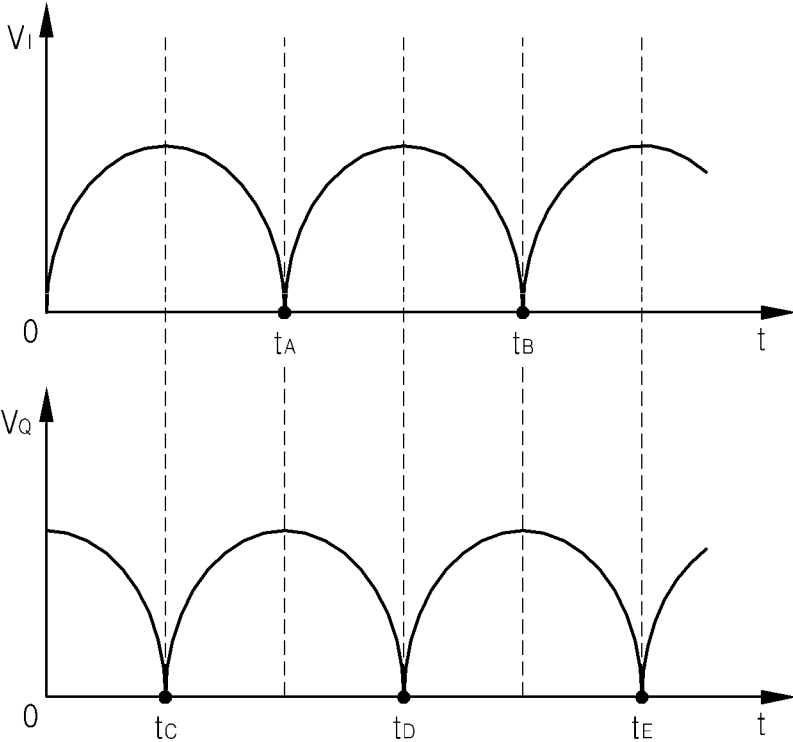

FIG. 15

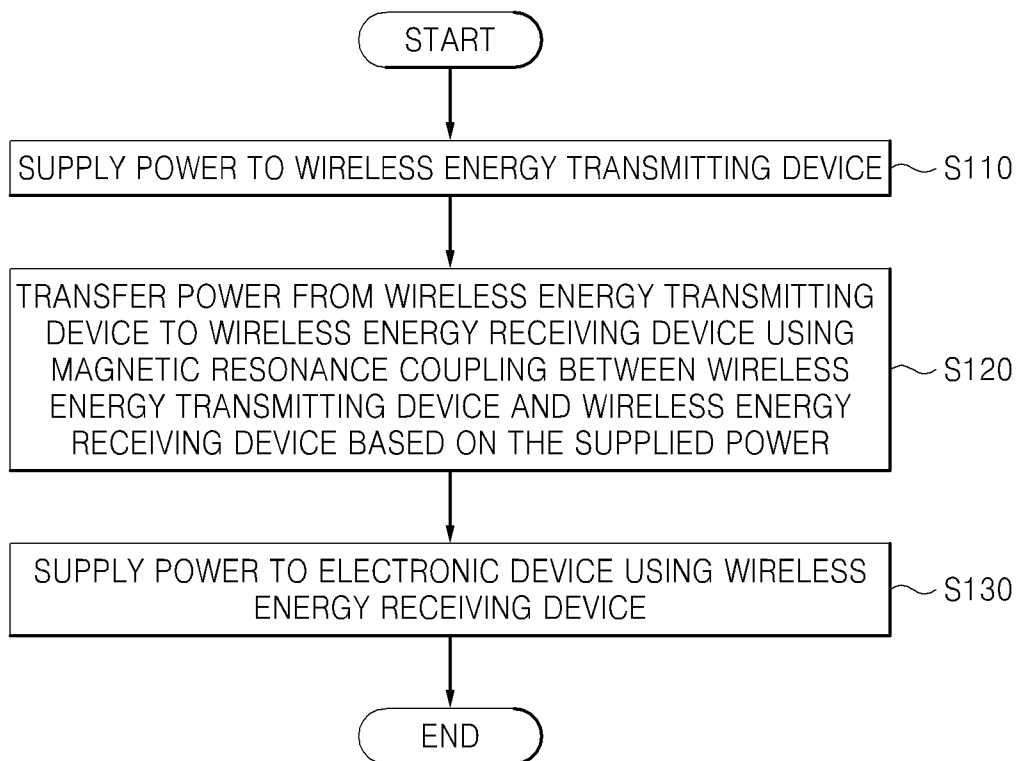

FIG. 16

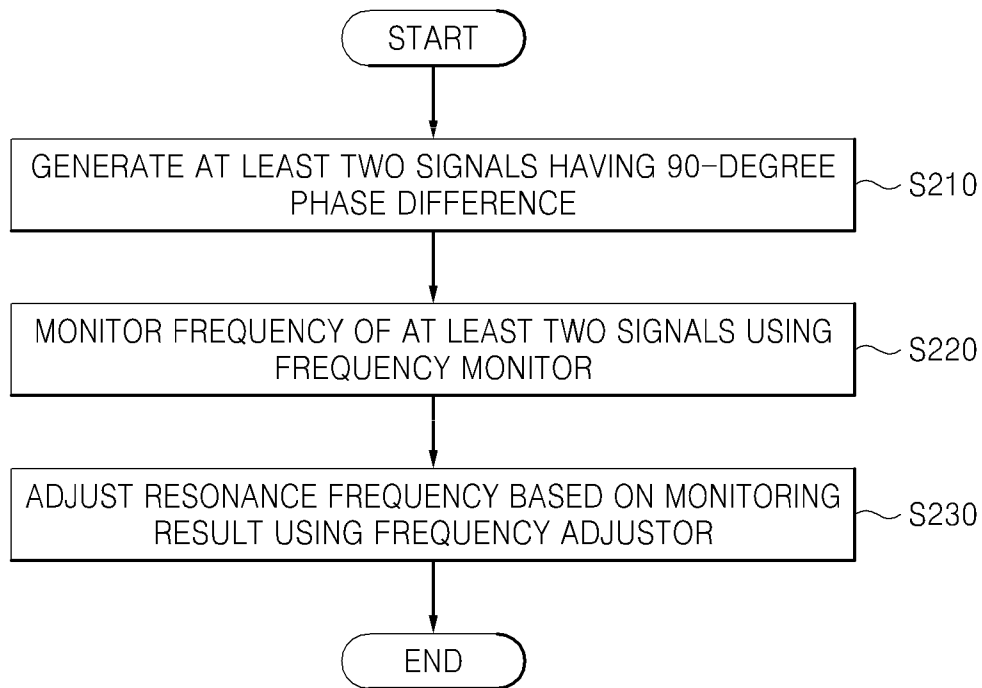

FIG. 17

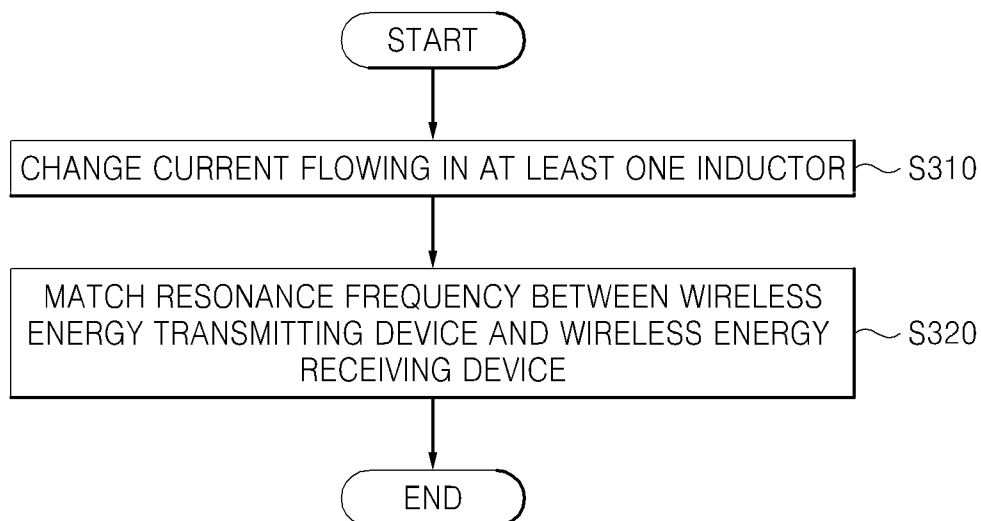

FIG. 18

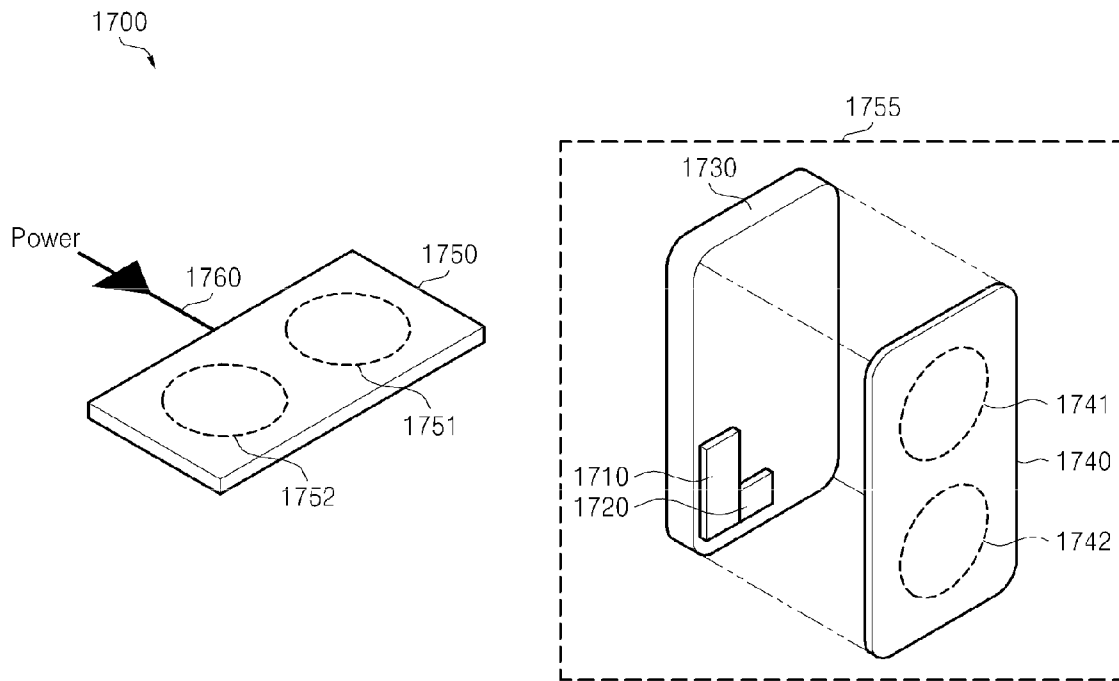

FIG. 19

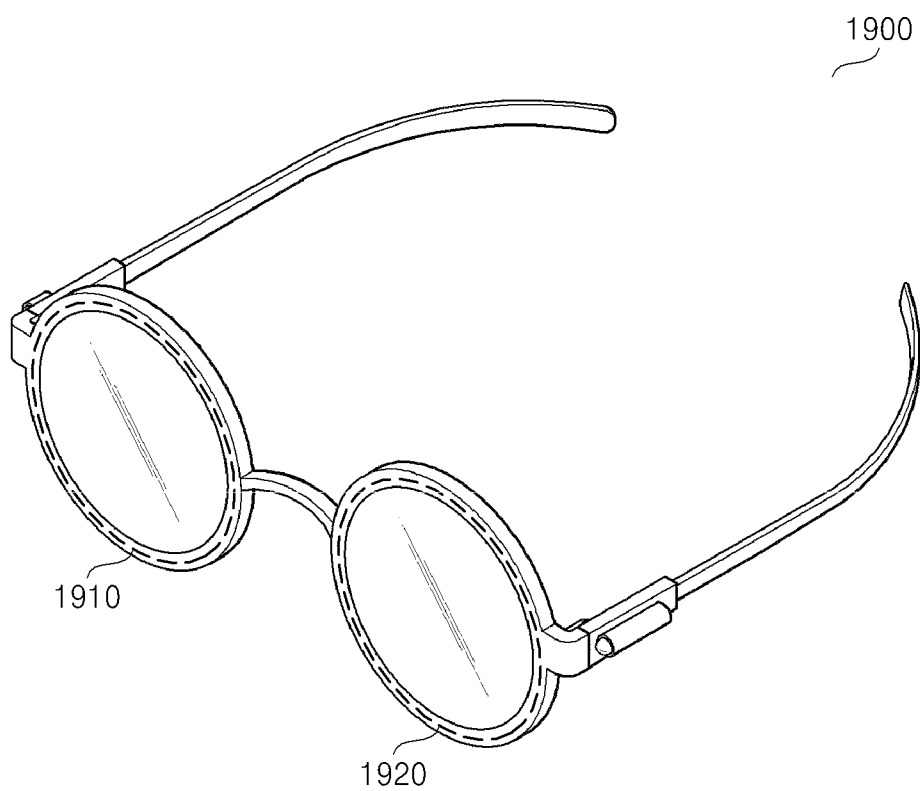

FIG. 20

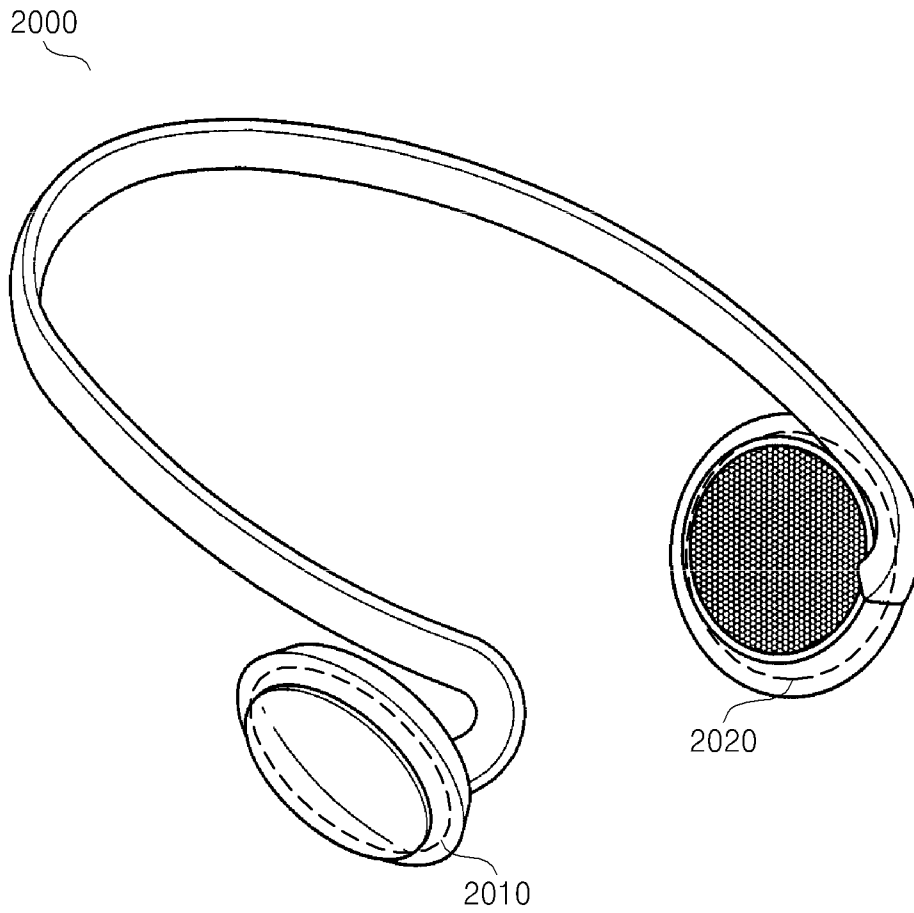

FIG. 21

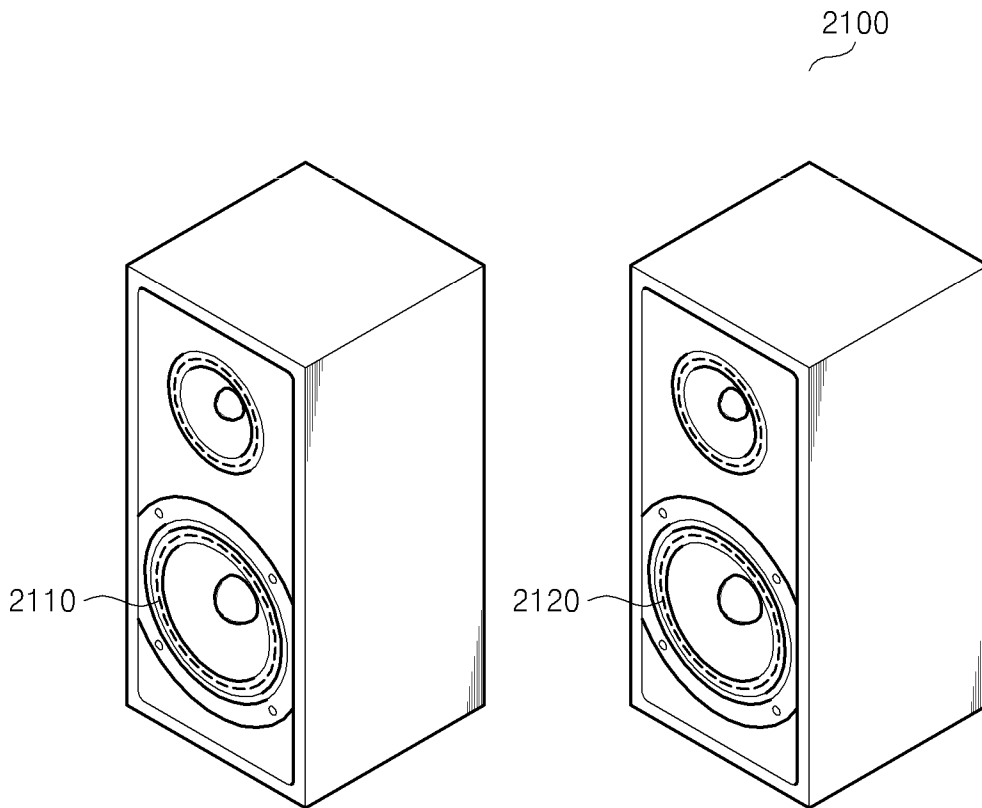

FIG. 22

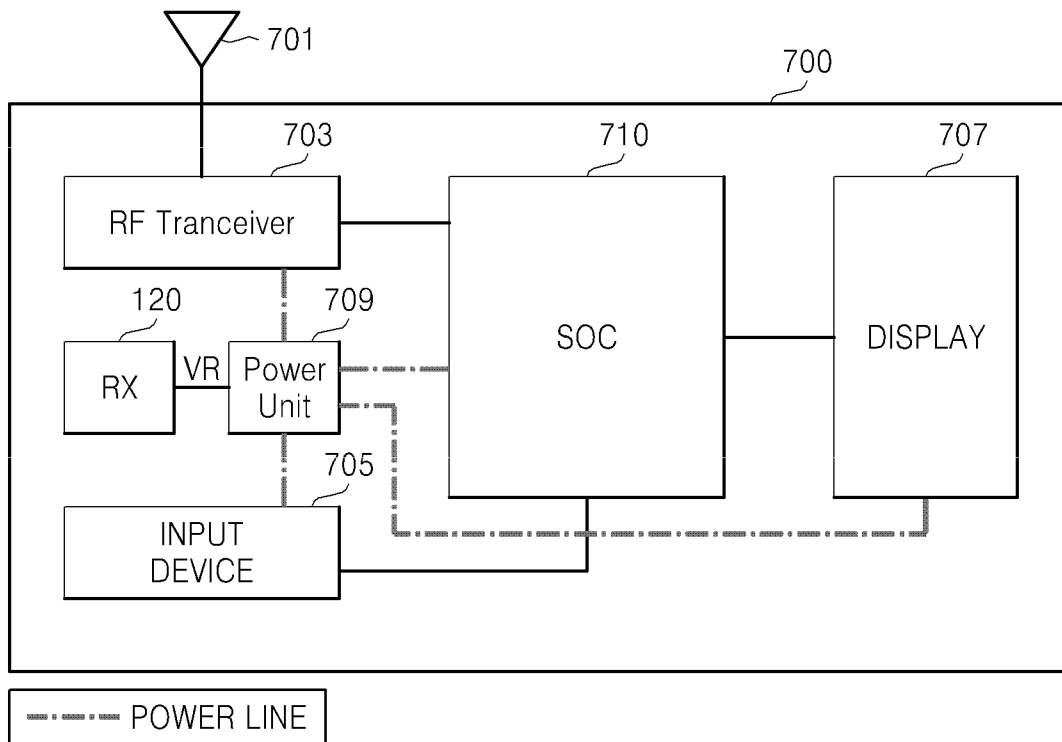

FIG. 23

800

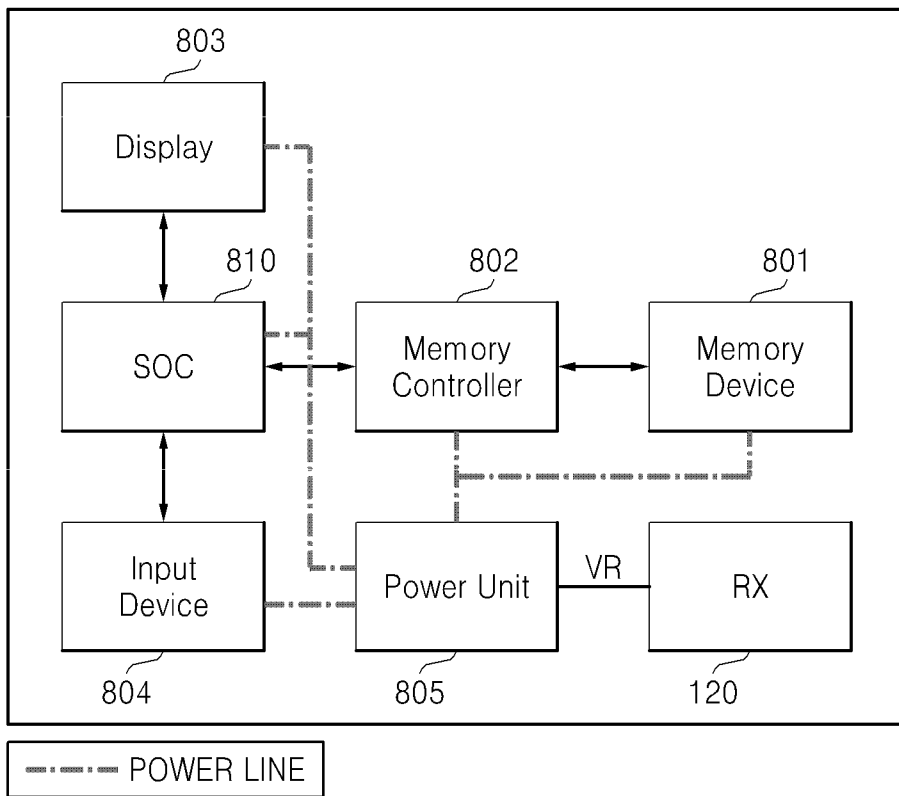

FIG. 24

900

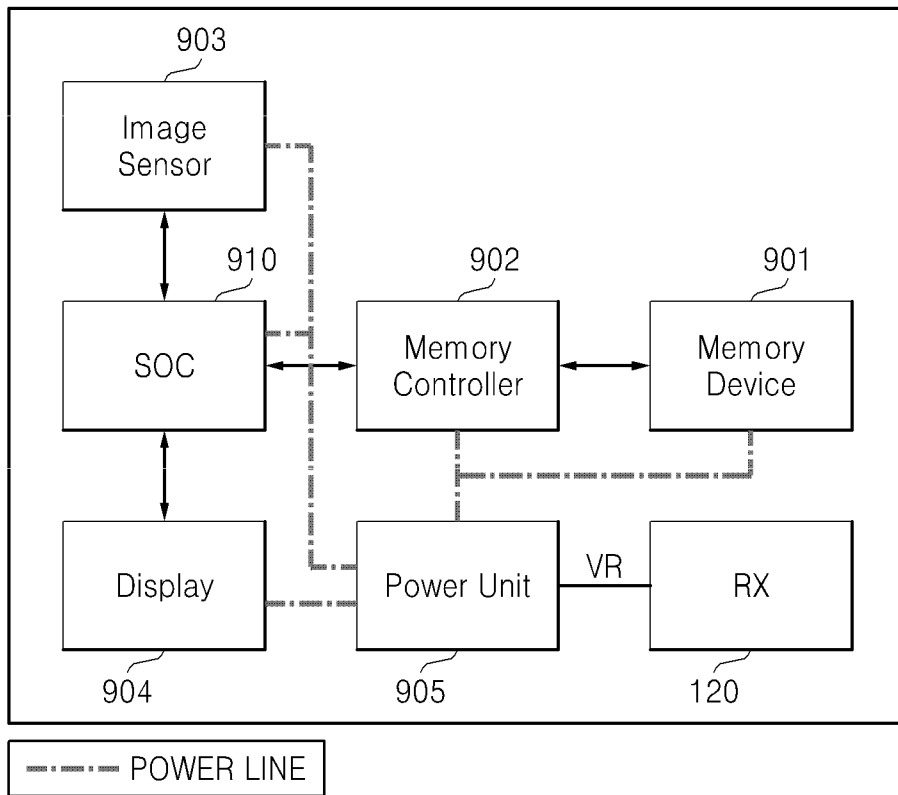

FIG. 25A

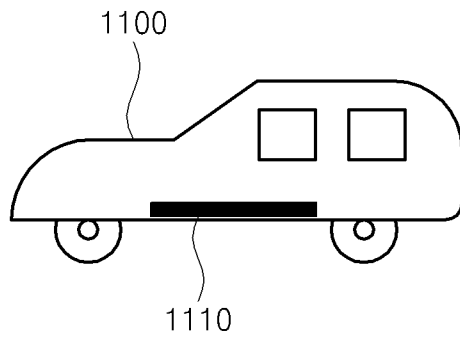
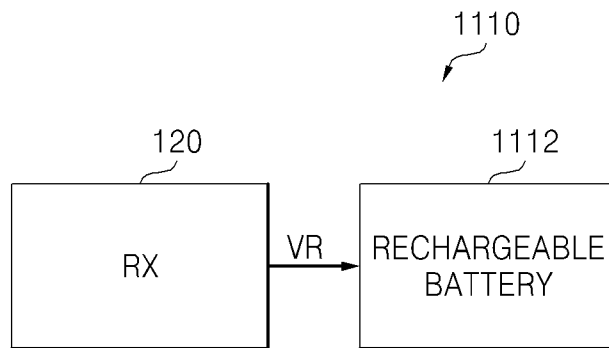

FIG. 25B



1

**WIRELESS ENERGY
RECEIVER/TRANSMITTER/SYSTEM AND
WIRELESS ENERGY TRANSMISSION
METHOD**

CROSS-REFERENCE TO RELATED
APPLICATIONS

This application claims priority under 35 U.S.C. §119 to Korean Patent Application No. 10-2011-0120520 filed on Nov. 17, 2011, the subject matter of which is hereby incorporated by reference.

BACKGROUND

Embodiments of the inventive concept relate to wireless energy receivers (receiving devices), wireless energy transmitters (transmitting devices), wireless energy transmission systems, and wireless energy transmission methods realizing efficient wireless energy transmission.

A great deal of research into wireless energy transmission using electromagnetic induction has been conducted. Yet, electrical power may be conventionally transmitted using electromagnetic induction across relatively short distances (e.g., several centimeters).

In order to overcome this limitation, a method of using magnetic resonance has been introduced. For wireless energy transmission using the magnetic resonance, LC resonance may be used and a common resonance frequency may be tuned between a transmitter/receiver pair. During this resonance frequency tuning process, the capacitance value is typically adjusted. However, it is not easy to finely adjust the capacitance value, and therefore, it is difficult to accurately perform resonance frequency tuning.

Accordingly, a better approach to resonance frequency tuning is desired that does not require direct adjustment the inductance value "L" or the capacitance value "C".

SUMMARY

According to certain embodiments of the inventive concept, there is provided a wireless energy transmission system including a wireless energy receiving device and a wireless energy transmitting device. At least one of the wireless energy receiving device and the wireless energy transmitting device comprises; a first oscillator configured to output an in-phase (I) signal, a second oscillator configured to output a quadrature-phase (Q) signal having a 90-degree phase difference from the I signal, wherein each of the first and second oscillators comprises a resonator having at least one inductor and at least one capacitor, and a current changing block connected to the at least one inductor and configured to change an amount of current flowing through the at least one inductor, and a monitor configured to monitor a frequency of at least one of the I and Q signals and control the current changing block according to a monitoring result.

According to certain embodiments of the inventive concept, there is provided a wireless energy receiving device comprising; a first oscillator configured to output an in-phase (I) signal, and a second oscillator configured to output a quadrature-phase (Q) signal having a 90-degree phase difference from the I signal. Each one of the first and second oscillators comprises; a first inductor pair having first mutual inductance and comprising a first inductor and a second inductor, a second inductor pair having second mutual inductance and comprising a third inductor and a fourth inductor, and a capacitor connected between the first inductor and the

2

third inductor, wherein each of the first and second oscillators controls a magnitude of received wireless energy by changing a resonance frequency by changing an amount of current flowing through the second and fourth inductors.

According to certain embodiments of the inventive concept, there is provided an electronic system comprising; a wireless energy receiving device configured to receive wireless energy from a wireless energy transmitting device through a magnetic field and generate reception power, and a power unit configured to receive the reception power from the wireless energy receiving device and supply at least a portion of internal power necessary for operation of the electronic system. The wireless energy receiving device comprises; a first oscillator configured to output an in-phase (I) signal, and a second oscillator configured to output a quadrature-phase (Q) signal having a 90-degree phase difference from the I signal. Each of the first and second oscillators comprises; a resonator comprising at least one inductor and at least one capacitor, and a current changing block connected to the at least one inductor to change an amount of current flowing through the at least one inductor.

According to certain embodiments of the inventive concept, there is provided a method of receiving wireless energy using a wireless energy receiving device, the method comprising; generating an in-phase (I) signal and a quadrature-phase (Q) signal having a 90-degree phase difference from the I signal using a quadrature oscillator comprising at least one pair of inductors having mutual inductance, and adjusting a resonance frequency by changing an amount of current flowing through one inductor in the at least one pair of inductors.

BRIEF DESCRIPTION OF THE DRAWINGS

The above and other features and advantages of the inventive concept will become more apparent by describing in detail exemplary embodiments thereof with reference to the attached drawings in which:

FIG. 1 is a general block diagram of a wireless energy transmission system according to embodiments of the inventive concept;

FIG. 2 is a block diagram of a transmitting device and receiving device that may be included in the wireless energy transmission system of FIG. 1 according to certain embodiments of the inventive concept;

FIG. 3 is a block diagram of a transmitting device and receiving device that may be included in the wireless energy transmission system of FIG. 1 according to other embodiments of the inventive concept;

FIG. 4 is a graph showing frequency versus quality factor "Q" for the wireless energy transmission system of FIG. 1;

FIG. 5 is a graph further illustrating resonance frequency versus the energy transfer rate in relation to selected quality factors;

FIGS. 6 and 7A are circuit diagrams of a quadrature oscillator that may be included in the transmitting device and/or a receiving device of FIG. 1 according to certain embodiments of the inventive concept;

FIG. 7B is a block diagram of a quadrature oscillator that may be included in the transmitting device and/or a receiving device of FIGS. 6 and 7A according to other embodiments of the inventive concept;

FIGS. 8, 9 and 10 are circuit diagrams illustrating the current changing block of FIGS. 6 and 7A according to certain embodiments of the inventive concept;

FIG. 11 is an equivalent circuit diagram for the resonant circuit block of FIGS. 6 and 7A;

FIGS. 12 and 13 are three-dimensional coordinate system diagrams illustrating inductors for the quadrature oscillator of FIG. 7A;

FIG. 14 is a diagram illustrating rectified waveforms that may be output by a quadrature oscillator according to certain embodiments of the inventive concept;

FIGS. 15, 16 and 17 are flowcharts that summarize wireless energy transmission methods according to certain embodiments of the inventive concept;

FIG. 18 is a diagram of a wireless energy transmission system according to certain embodiments of the inventive concept;

FIGS. 19, 20 and 21 are diagrams illustrating certain receiving devices according to embodiments of the inventive concept;

FIG. 22 is a block diagram of an electronic system including a wireless energy receiving device according to embodiments of the inventive concept;

FIG. 23 is a block diagram of an electronic system including a wireless energy receiving device according to other embodiments of the inventive concept;

FIG. 24 is a block diagram of an electronic system including a wireless energy receiving device according to further embodiments of the inventive concept; and

FIGS. 25A and 25B are conceptual diagrams illustrating an automotive application for a wireless energy receiving device according to certain embodiments of the inventive concept.

DETAILED DESCRIPTION OF THE EMBODIMENTS

The inventive concept now will be described in some additional detail with reference to the accompanying drawings. The invention may, however, be embodied in many different forms and should not be construed as being limited to only the illustrated embodiments. Rather, these embodiments are provided so that this disclosure will be thorough and complete, and will fully convey the scope of the invention to those skilled in the art. Throughout the written description and drawings, like reference numbers and labels denote like or similar elements.

It will be understood that when an element is referred to as being “connected” or “coupled” to another element, it can be directly connected or coupled to the other element or intervening elements may be present. In contrast, when an element is referred to as being “directly connected” or “directly coupled” to another element, there are no intervening elements present. As used herein, the term “and/or” includes any and all combinations of one or more of the associated listed items and may be abbreviated as “/”.

It will be understood that, although the terms first, second, etc. may be used herein to describe various elements, these elements should not be limited by these terms. These terms are only used to distinguish one element from another. For example, a first signal could be termed a second signal, and, similarly, a second signal could be termed a first signal without departing from the teachings of the disclosure.

The terminology used herein is for the purpose of describing particular embodiments only and is not intended to be limiting of the invention. As used herein, the singular forms “a”, “an” and “the” are intended to include the plural forms as well, unless the context clearly indicates otherwise. It will be further understood that the terms “comprises” and/or “comprising,” or “includes” and/or “including” when used in this specification, specify the presence of stated features, regions, integers, steps, operations, elements, and/or components, but do not preclude the presence or addition of one or more other

features, regions, integers, steps, operations, elements, components, and/or groups thereof.

Unless otherwise defined, all terms (including technical and scientific terms) used herein have the same meaning as commonly understood by one of ordinary skill in the art to which this invention belongs. It will be further understood that terms, such as those defined in commonly used dictionaries, should be interpreted as having a meaning that is consistent with their meaning in the context of the relevant art and/or the present application, and will not be interpreted in an idealized or overly formal sense unless expressly so defined herein.

FIG. 1 is a general block diagram of a wireless energy transmission system 100 according to certain embodiments of the inventive concept. The wireless energy transmission system 100 comprises a transmitting device 110 and a receiving device 120. The transmitting device 110 and the receiving device 120 are separated by a distance “D” (e.g., several centimeters).

The transmitting device 110 may transfer energy to the receiving device 120 via a wireless connection, where the transmitting device 110 and receiving device 120 include a resonator (not shown). The resonator may be an inductance “L”/capacitance “C” (or LC) resonator, but the inventive concept is not restricted thereto.

The transmitting device 110 is connected to a power supply 130 to receive a first power voltage VS1. Wireless energy is transmitted from the transmitting device 110 to the receiving device 120 via an induced magnetic field. That is, a transfer of magnetic energy may be carried out between an inductor included in the transmitting device 110 and an inductor included in the receiving device 120.

The receiving device 120 is connected to a power consumption device 140. The power consumption device 140 consumes power derived from the energy transferred via the wireless connection. For instance, the receiving device 120 may convert the received wireless energy into reception power VR and provide the reception power VR to the power consumption device 140. The power consumption device 140 may use the reception power VR supplied from the receiving device 120 and/or a separate supply power voltage VS2.

The wireless energy transmission system 100 generally includes two devices, i.e., the transmitting device 110 and the receiving device 120, but embodiments of the inventive concept are restricted thereto. The wireless energy transmission system 100 may include three or more devices. In addition, the receiving device 120 and the power consumption device 140 are illustrated as separate elements in FIG. 1, but they may be implemented in a single element.

FIG. 2 is a block diagram further illustrating the transmitting device 110 and receiving device 120 of the wireless energy transmission system 100a illustrated in FIG. 1. Referring to FIG. 2, the transmitting device 110 includes a fixed frequency oscillator 112. The receiving device 120 includes a variable frequency oscillator 121, a frequency adjuster 122, and a frequency monitor 124.

The fixed frequency oscillator 112 outputs a signal having a fixed frequency. The fixed frequency oscillator 112 and the variable frequency oscillator 121 may include a quadrature oscillator (not shown). The fixed frequency oscillator 112 may output an in-phase (I) signal having a positive signal and a negative signal and a quadrature-phase (Q) signal having a quadrature-phase signal of the positive signal and a quadrature-phase signal of the negative signal. The variable frequency oscillator 121 receives the I and Q signals from the

5

fixed frequency oscillator **112** via a wireless connection. This will be described in some additional detail with reference to FIGS. **6** and **7A**.

The frequency monitor **124** monitors the frequency of the variable frequency oscillator **121** and outputs a control signal CON that controls the frequency adjuster **122**.

The frequency adjuster **122** adjusts the frequency of the receiving device **120** based on the control signal CON so that the frequency of the receiving device **120** is the same as that of the transmitting device **110**. In other words, the frequency adjuster **122** changes the frequency of the variable frequency oscillator **121** in response to the control signal CON of the frequency monitor **124**.

In other embodiments of the inventive concept, different approaches such as use of a power monitor (not shown) or a Hall sensor (not shown) may be used instead of the frequency monitor **124**. The power monitor may monitor the strength of wireless energy that the receiving device **120** receives from the transmitting device **110** and output the control signal CON to increase the magnitude of the wireless energy. The strength of the wireless energy may be monitored by measuring the strength of the I and Q signals. Alternately, a Hall sensor may detect the strength of a magnetic field and output the control signal CON to increase the strength of the magnetic field. This approach will be described in some additional detail with reference to FIGS. **6** through **9**.

FIG. **3** is a schematic block diagram of a transmitting device **110'** and a receiving device **120'** included in the wireless energy transmission system **100b** illustrated in FIG. **1** according to other embodiments of the inventive concept. Referring to FIG. **3**, the transmitting device **110'** includes a variable frequency oscillator **112'**, a frequency adjuster **114**, and a frequency monitor **116**. The receiving device **120'** includes a fixed frequency oscillator **121'**.

The variable frequency oscillator **112'** generates a signal having a frequency that can be varied by the frequency adjuster **114**. The variable frequency oscillator **112'** and the fixed frequency oscillator **121'** may include a quadrature oscillator (not shown). The variable frequency oscillator **112'** outputs an I signal, which includes a positive signal and a negative signal, and a Q signal, which includes a quadrature-phase output signal of the positive signal and a quadrature-phase output signal of the negative signal. The fixed frequency oscillator **121'** receives the I and Q signals from the variable frequency oscillator **112'** via a wireless connection. This approach will be described in some additional detail with reference to FIGS. **6** and **7A**.

The frequency monitor **116** monitors the frequency of the variable frequency oscillator **112'** and outputs a control signal CON for controlling the frequency adjuster **114**.

The frequency adjuster **114** adjusts the frequency of the transmitting device **110'** based on the control signal CON so that the frequency of the transmitting device **110'** is the same as that of the receiving device **120'**. This will be described in detail with reference to FIGS. **6** through **9** later.

FIG. **4** is a graph illustrating relationships between frequency and quality factor "Q" in the wireless energy transmission system **100** of FIG. **1**. In FIG. **4**, a curve Q_1 indicates the quality factor of the transmitting device **110** and a curve Q_2 indicates the quality factor of the receiving device **120**. When the receiving device **120** has a frequency of W_2 , energy transfer efficiency decreases according to the quality factor Q_1 of the transmitting device **110**. In particular, the higher quality factor the wireless energy transmission system **100** requires, the greater the change in the energy transfer efficiency depending on the change in frequency.

6

The transmitting device **110** has a maximum quality factor at the frequency W_1 , and therefore, the efficiency of energy transfer to the receiving device **120** is maximum at the frequency W_1 .

Accordingly, the energy transfer efficiency can be increased by matching resonance frequency between the transmitting device **110** and the receiving device **120** by adjusting the frequency of the receiving device **120** from W_2 to W_1 .

FIG. **5** is a diagram illustrating resonance frequency versus an energy transfer rate of V_R/V_T as a function of quality factor. Referring to FIG. **5**, the quality factor decreases in order of a first plot **410**, a second plot **420**, and a third plot **430**.

Referring to the first graph **410** having the highest quality factor, the energy transfer rate V_R/V_T rapidly drops when the resonance frequency even slightly changes.

Accordingly, when the wireless energy transmission system **100** of FIG. **1** requires a high quality factor, matching of the resonance frequency between the transmitting device **110** and the receiving device **120** may be very important.

FIGS. **6** and **7A** are circuit diagrams illustrating a quadrature oscillator **600** that may be included in the transmitting device **110** and/or the receiving device **120** of the wireless transmission system **100** of FIG. **1** according to certain embodiments of the inventive concept. In other words, the quadrature oscillator **600** illustrated in FIGS. **6** and **7A** may be used in the embodiments including the variable frequency oscillator **121** and the frequency adjuster **122** illustrated in FIG. **2** and may also be used in the embodiments including the variable frequency oscillator **112'** and the frequency adjuster **114** illustrated in FIG. **3**. Hereinafter, a case using the quadrature oscillator **600** in the embodiments including the variable frequency oscillator **121** and the frequency adjuster **122** illustrated in FIG. **2** will be described. The quadrature oscillator **600** illustrated in FIG. **6** is equivalent to that illustrated in FIG. **7A**.

Referring to FIGS. **6** and **7A**, the quadrature oscillator **600** includes a first oscillator **605a** and a second oscillator **605b**.

The first oscillator **605a** may output an I signal and the second oscillator **605b** may output a Q signal that has a 90-degree phase difference from the I signal.

The first oscillator **605a** includes a resonance circuit block **610a**, a negative resistance block **615a**, a coupling circuit block **620a**, a bias block **630a**, and a current changing block **640a**. The second oscillator **605b** includes a resonance circuit block **610b**, a negative resistance block **615b**, a coupling circuit block **620b**, a bias block **630b**, and a current changing block **640b**.

The resonance circuit block **610a** includes inductors L_1 and L_2 and capacitors C_1 and C_2 and determines the frequency of I signals I_p and I_n . Mutual inductance occurs between the inductors L_1 and L_2 and a mutual inductance value is M.

The resonance circuit block **610b** includes inductors L_3 and L_4 and capacitors C_3 and C_4 and determines the frequency of Q signals Q_p and Q_n . Mutual inductance occurs between the inductors L_1 and L_2 and a mutual inductance value is M.

Each of the inductors L_1 , L_2 , L_3 , and L_4 may be implemented as an on-chip inductor, but the inventive concept is not restricted thereto. The on-chip inductor may be implemented with conductor (e.g., metal) wiring on a semiconductor chip.

The resonance circuit block **610a** has positive resistance inherent in the inductors L_1 and L_2 and the capacitors C_1 and C_2 a when it is not ideal, and therefore, the output of the resonance circuit block **610a** may exhibit the response characteristics of an RLC circuit. As a result, damping oscillation may occur.

The resonance circuit block **610b** also has positive resistance inherent in the inductors L_3 and L_4 and the capacitors C_3 and C_4 when it is not ideal, and therefore, the output of the resonance circuit block **610b** may exhibit the response characteristics of an RLC circuit. As a result, damping oscillation may occur.

Accordingly, the negative resistance blocks **615a** and **615b** are connected to the resonance circuit blocks **610a** and **610b**, respectively, to generate negative resistance counterbalancing the positive resistance of the resonance circuit blocks **610a** and **610b**.

The negative resistance block **615a** includes cross-coupled N-type metal oxide semiconductor (NMOS) transistors T_1 and T_2 . The NMOS transistors T_1 and T_2 are cross-coupled so that the negative I signal I_n is output through a terminal of the NMOS transistor T_2 and is input to a gate of the NMOS transistor T_1 and the positive I signal I_p is output through a terminal of the NMOS transistor T_1 and is input to a gate of the NMOS transistor T_2 .

The negative resistance block **615b** includes cross-coupled NMOS transistors T_3 and T_4 . The NMOS transistors T_3 and T_4 are cross-coupled so that the negative Q signal Q_n is output through a terminal of the NMOS transistor T_4 and is input to a gate of the NMOS transistor T_3 and the positive Q signal Q_p is output through a terminal of the NMOS transistor T_3 and is input to a gate of the NMOS transistor T_4 .

The coupling circuit block **620a** includes two NMOS transistors T_5 and T_6 . The coupling circuit block **620b** includes two NMOS transistors T_7 and T_8 . The coupling circuit blocks **620a** and **620b** may couple the first and second oscillators **605a** and **605b**, respectively.

The positive Q signal Q_p is input to a gate of the NMOS transistor T_5 and the negative Q signal Q_n is input to a gate of the NMOS transistor T_6 .

The negative I signal I_n is input to a gate of the NMOS transistor T_7 and the positive I signal I_p is input to a gate of the NMOS transistor T_8 .

The bias blocks **630a** and **630b** are connected to the negative resistance blocks **615a** and **615b**, respectively, and include NMOS transistors T_9 and T_{10} , respectively.

The NMOS transistors T_9 and T_{10} adjust bias currents I_{b1} and I_{b2} , respectively, based on bias voltages V_{b1} and V_{b2} , respectively, input to their gates.

The current changing block **640a** may change current flowing in the resonance circuit block **610a** based on an input control signal CON_1 received from the frequency monitor **124**. The current changing block **640b** may change current flowing in the resonance circuit block **610b** based on an input control signal CON_2 received from the frequency monitor **124**.

For instance, currents I_{c1} and I_{c2} may be changed based on the input control signals CON_1 and CON_2, respectively. Currents flowing in the resonance circuit blocks **610a** and **610b**, and more particularly, currents flowing in the inductors L_2 and L_4 may be changed by the coupling circuit blocks **620a** and **620b**. The input control signals CON_1 and CON_2 may be digital signals of at least two bits. The input control signals CON_1 and CON_2 may be the same as or different from each other. The input control signals CON_1 and CON_2 may be symmetrical (e.g., complementary) to each other.

The current changing blocks **640a** and **640b** will be described in some additional detail with reference to FIGS. **8**, **9** and **10**.

Consequently, the frequency of a signal generated by the first and second oscillators **605a** and **605b** is changed without directly changing the inductance of the inductors L_1 through

L_4 and the capacitance of the capacitors C_1 through C_4 . This will be described in detail with reference to FIG. **11** later.

FIG. **7B** is a block diagram of the receiving device **120** of FIG. **1** according to certain embodiments of the inventive concept. Referring to FIGS. **6** through **7B**, the receiving device **120** further includes a bias voltage generator **650** and a rectifier **660** in the quadrature oscillator **600** illustrated in FIGS. **6** and **7A**. It will be apparent to those skilled in the art that the receiving device **120** may include the frequency monitor **124** of FIG. **2** or the frequency monitor **116** of FIG. **3**.

The bias voltage generator **650** generates the bias voltages V_{b1} and V_{b2} input to the gates of the respective NMOS transistors T_9 and T_{10} . The rectifier **660** converts the I signals I_p and I_n output from the resonance circuit block **610a** and the Q signals Q_p and Q_n output from the resonance circuit block **610b** into the reception power VR. For instance, the rectifier **660** may rectify alternating current (AC) power based on the I signals I_p and I_n and the Q signals Q_p and Q_n , thus generating direct current (DC) power, i.e., the reception power VR.

FIG. **7B** is a block diagram of a receiving device consistent with embodiments of the inventive concept, but a transmitting device may be similarly configured.

FIGS. **8**, **9** and **10** are circuit diagrams of the current changing blocks **640a** and **640b** of FIGS. **6** and **7** according to certain embodiments of the inventive concept. Only the current changing block **640a** will be described in detail to avoid redundancy since the structure and operation of the current changing block **640a** may be the same as those of the current changing block **640b**.

In the example illustrated in FIG. **8**, the current changing block **640a** includes at least two NMOS transistors but may variously configured (e.g., with four NMOS transistors T_A , T_B , T_C , and T_D).

Referring to FIG. **8**, the input control signal CON_1 is applied to gates of the respective NMOS transistors T_A , T_B , T_C , and T_D . The NMOS transistors T_A , T_B , T_C , and T_D are selectively switched in response to the input control signal CON_1. The input control signal CON_1 may be a 4-bit digital signal. When the 4-bit digital signal is "1100", the two NMOS transistors T_A and T_B among the four NMOS transistors T_A , T_B , T_C , and T_D are switched ON and the other two NMOS transistors T_C and T_D are switched OFF.

The four NMOS transistors T_A , T_B , T_C , and T_D may have different width-to-length ratios, so that current flowing in each of the NMOS transistors T_A , T_B , T_C , and T_D can be changed. As a result, the current I_{c1} can be changed.

A node NO in FIG. **8** corresponds to a node N_1 or N_2 in FIGS. **6** and **7A**.

The current changing block **640a** may be formed as a circuit including a current mirror and is configured to include four NMOS transistors TR_1 , TR_2 , TR_3 , and TR_4 and a current source I_A in the embodiments illustrated in FIG. **9**.

Referring to FIG. **9**, the input control signal CON_1 is applied to switches SW1 and SW2, which control an open and close (e.g., 0 and 1) switching operation in the current mirror.

The opening/closing of the switches SW1 and SW2 is controlled using the input control signal CON_1, so that the current I_{c1} is changed. The input control signal CON_1 may be a 2-bit digital signal. When the input control signal CON_1 is "10", the switch SW1 is closed while the switch SW2 is opened.

In a case where the first and second switches SW1 and SW2 are opened, current I_A flowing in the NMOS transistor TR_1 flows in the NMOS transistor TR_2 and no current flows in the NMOS transistors TR_3 and TR_4 . Accordingly, the current I_{c1} is the same as the current I_A .

In a case where only the first switch SW1 is closed, the current I_A flows in the NMOS transistor TR₃ as well as the NMOS transistor TR₂. As a result, the current I_{c1} becomes $2I_A$.

In a case where both of the first and second switches SW1 and SW2 are closed, the current I_A flows in the NMOS transistors TR₃ and TR₄ as well as the NMOS transistor TR₂. As a result, the current I_{c1} becomes $3I_A$.

It is apparent that the amount of the current I_{c1} will also be differently adjusted when the size of the NMOS transistors TR₁, TR₂, TR₃, and TR₄ is changed.

A node N1 in FIG. 9 corresponds to the node N_1 or N_2 in FIGS. 6 and 7A.

The current changing block 640a may be formed as a circuit including a current mirror and is configured to include two NMOS transistors TR₅ and TR₆ and three current sources I_B , I_C , and I_D in the embodiments illustrated in FIG. 10.

Referring to FIG. 10, the input control signal CON_1 is applied to switches SW3, SW4, and SW5, which control an open and close (e.g., 0 and 1) switching operation in the current sources I_B , I_C , and I_D .

The opening/closing of the switches SW3, SW4, and SW5 is controlled using the input control signal CON_1, so that the current I_{c1} is changed. The input control signal CON_1 may be a 3-bit digital signal. When the input control signal CON_1 is "110", the switches SW3 and SW4 are closed while the switch SW5 is opened.

In a case where the third switch SW3 is closed and the fourth and fifth switches SW4 and SW5 are opened, current I_B flowing in the NMOS transistor TR₅ flows in the NMOS transistor TR₆. Accordingly, the current I_{c1} is the same as the current I_B .

In a case where the third and fourth switches SW3 and SW4 are closed and the fifth switch SW5 is opened, current I_B+I_C flows in the NMOS transistor TR₆. Accordingly, the current I_{c1} becomes I_B+I_C .

In a case where all of the third through fifth switches SW3, SW4, and SW5 are closed, current $I_B+I_C+I_D$ flows in the NMOS transistor TR₆. Accordingly, the current I_{c1} becomes $I_B+I_C+I_D$.

It is apparent that the amount of the current I_{c1} will also be differently adjusted when the size of the NMOS transistors TR₅ and TR₆ is changed.

A node N2 in FIG. 10 corresponds to the node N_1 or N_2 in FIGS. 6 and 7A.

FIG. 11 is an equivalent circuit diagram for the resonant circuit block 610a or 610b of FIGS. 6 and 7. One approach to the adjustment of the resonance frequency in the resonant circuit blocks 610a and 610b will be described with reference to FIG. 11.

When the frequency of the equivalent circuit illustrated in FIG. 11 is denoted by "w", the following relationship exists:

$$V_E = jwL_1 i_{L1} + jwM i_{L2} = i_{L1} / (jwC_E) \quad (1)$$

In the quadrature oscillator 600 illustrated in FIGS. 6 and 7A, current i_{L1} flowing in the inductor L_1 and current i_{L2} flowing in the inductor L_2 have a 0- or 180-degree phase difference from each other. Accordingly, $i_{L2} = \alpha i_{L1}$ where α is a real number. Equation 1 may be rewritten as Equation 2:

$$V_E = jw(L_1 + \alpha M) i_{L1} \quad (2)$$

Consequently, the value of α can be changed by changing the current i_{L2} flowing in the inductor L_2 , so that an inductance value viewed from a capacitor C_E can be changed.

Generally, a resonance frequency w_0 with respect to a capacitor C and an inductor L is defined as

$$\sqrt{\frac{1}{LC}}$$

and therefore, the resonance frequency of the resonant circuit blocks 610a and 610b can be changed.

Referring to FIG. 11, when the current i_{L2} flowing in the inductor L_2 is changed by the current changing blocks 640a and 640b, an inductance value viewed from the capacitor C_E is changed from L_1 to $L_1 + \alpha M$. Accordingly, the resonance frequency of the resonant circuit blocks 610a and 610b can be changed.

FIGS. 12 and 13 are three-dimensional coordinate system diagrams illustrating inductors of the quadrature oscillator 600 of FIG. 7A according to certain embodiments of the inventive concept. FIG. 12 shows the inductors L_1 and L_2 of the first oscillator 605a in the quadrature oscillator 600. FIG. 13 shows the inductors L_3 and L_4 of the second oscillator 605b in the quadrature oscillator 600.

FIGS. 12 and 13 show that the inductors L_1 and L_2 are disposed perpendicular to the inductors L_3 and L_4 , but the inventive concept is not restricted to the current embodiments. For instance, the inductors L_1 and L_2 may be disposed in parallel to the inductors L_3 and L_4 or may be disposed at a certain angle (e.g., 0 through 180 degrees) to the inductors L_3 and L_4 .

When the transmitting device 110 includes the quadrature oscillator 600 illustrated in FIGS. 12 and 13, even if an inductor (not shown) included in the receiving device 120 is perpendicular to the inductors L_1 and L_2 of the first oscillator 605a, a Q signal orthogonal to an I signal output from the second oscillator 605b can be output using the inductors L_3 and L_4 of the second oscillator 605b, so that energy can be transferred to the receiving device 120.

In other words, when the inductors L_1 and L_2 of the first oscillator 605a are disposed in a perpendicular relationship with the inductors L_3 and L_4 of the second oscillator 605b in the transmitting device 110, the receiving device 120 can be stably receive wireless energy without being much bound by the positions of the inductors L_1 , L_2 , L_3 , and L_4 included in the receiving device 120.

The transmitting device 110 may be installed in a particular region (hereinafter, referred to as a "charge zone") so that the receiving device 120 can receive wireless energy. The charge zone may be the inside or outside of a building or an automobile. The transmitting device 110 may be installed in the charge zone such that the inductors L_1 and L_2 of the first oscillator 605a are at right angles to the inductors L_3 and L_4 of the second oscillator 605b.

FIG. 14 is a diagram of rectified waveforms output from a quadrature oscillator according to certain embodiments of the inventive concept. The quadrature oscillator 600 illustrated in FIG. 7A outputs rectified outputs V_I and V_Q having the waveforms illustrated in FIG. 14 over time.

When only one of the waveforms of the rectified outputs V_I and V_Q is used to transfer energy to the receiving device 120, a problem may occur due to discontinuity at zero voltage points t_A , t_B , t_C , t_D , and t_E .

However, when both of the transmitting device 110 and the receiving device 120 include the quadrature oscillator 600 according to embodiments of the inventive concept, one of the rectified outputs V_I and V_Q is at a peak at the zero voltage points t_A and t_B or t_C , t_D , and t_E of the other one of the rectified outputs V_I and V_Q . As a result, energy transfer can be performed more efficiently.

FIGS. 15, 16 and 17 are flowcharts summarizing wireless energy transmission methods according to embodiments of the inventive concept. The wireless energy transmission method may be performed by the wireless energy transmission system 100 of FIG. 1.

FIG. 15 is a general flowchart for the wireless energy transmission method performed by the wireless energy transmission system 100. FIG. 16 is a flowchart more particularly describing the frequency adjustment performed by the transmitting device 110 or the receiving device 120 of the wireless energy transmission system 100, and FIG. 17 is a flowchart even more particularly describing the frequency adjustment.

Referring to FIG. 15, power is supplied by a power supply to a wireless energy transmitting device (S110).

Based on the supplied power, power is transferred from the wireless energy transmitting device to a wireless energy receiving device through a magnetic field between the wireless energy transmitting device and the wireless energy receiving device (S120). In order efficiently transfer power to the wireless energy receiving device, frequency matching is performed between the wireless energy transmitting device and the wireless energy receiving device.

For the frequency matching, a frequency of the wireless energy receiving device may be adjusted. At least two signals having a 90-degree phase difference may be transmitted to the wireless energy receiving device. The amount of current flowing in an inductor within the wireless energy receiving device may be changed so that the frequency matching between the wireless energy transmitting device and the wireless energy receiving device can be accomplished. As described above, in other embodiments, a frequency of the wireless energy transmitting device may be adjusted.

The power transferred to the wireless energy receiving device is supplied to a power consumption electronic device connected to the wireless energy receiving device (S130).

Referring to FIG. 16, a signal generator generates at least two signals (e.g., an I signal and a Q signal) having a 90-degree phase difference (S210).

A frequency monitor monitors a frequency of the at least two signals (S220). A frequency adjuster adjusts the frequency of the wireless energy receiving device based on a monitoring result (S230) so that the frequency matching between the wireless energy transmitting device and the wireless energy receiving device is accomplished. That is, the frequency may be adjusted by changing the amount of current flowing in an inductor within the wireless energy receiving device.

Referring to FIG. 17, for the frequency matching between the wireless energy transmitting device and the wireless energy receiving device, the amount of current flowing in an inductor within the wireless energy receiving device is changed (S310).

Accordingly, a resonance frequency is matched between the wireless energy transmitting device and the wireless energy receiving device (S320). Once the frequency matching is accomplished, energy can be efficiently transferred to the wireless energy receiving device.

As described above, in the wireless energy transmission method according to the embodiments illustrated in FIGS. 15, 16 and 17, the resonance frequency is tuned without directly adjusting an inductance value or a capacitance value, thereby realizing efficient wireless energy transmission.

FIG. 18 is a diagram of a wireless energy transmission system 1700 according to certain embodiments of the inventive concept. Referring to FIG. 18, the wireless energy transmission system 1700 includes a transmitting device 1750 and a receiving device 1755. The transmitting device 1750 may be

implemented in a form of a pad for transmitting energy and the receiving device 1755 may be a mobile device, e.g., a portable phone.

Although not shown, the transmitting device 1750 may be installed at a particular place or position, e.g., a wall, a table, or a bag, in a predetermined distance from the receiving device 1755 in order to transmit wireless energy to the receiving device 1755. The receiving device 1755 can receive energy from the transmitting device 1750 even if it is not in contact with or in a short distance from the receiving device 1755.

The transmitting device 1750 includes a first oscillator 1751 and a second oscillator 1752, which forms a quadrature oscillator, and is supplied with power from the outside through a connector 1760.

The receiving device 1755 includes a portable phone body 1730 and a portable phone case 1740. The portable phone body 1730 includes a battery 1710 and a charger 1720. The portable phone case 1740 includes a first oscillator 1741 and a second oscillator 1742, which forms a quadrature oscillator.

When power is supplied to the transmitting device 1750, energy is transmitted by the first and second oscillators 1751 and 1752 of the transmitting device 1750 to the first and second oscillators 1741 and 1742 of the receiving device 1755.

When the energy is transmitted to the receiving device 1755, the receiving device 1755 may charge the battery 1710 with the energy through the charger 1720.

Although the first and second oscillators 1741 and 1742 of the receiving device 1755 are positioned within the portable phone case 1740 in the embodiments illustrated in FIG. 18, the scope of the inventive concept is not restricted to these embodiments. For instance, the first and second oscillators 1741 and 1742 may be positioned within the portable phone body 1730.

FIGS. 19, 20 and 21 are diagrams of the receiving device 120 according to different embodiments of the inventive concept. Unlike the embodiments illustrated in FIG. 18, the transmitting device 110 is omitted in the embodiments illustrated in FIGS. 19 through 21.

Referring to FIG. 19, the receiving device 120 may be implemented in a form of three-dimensional (3D) glasses 1900. The 3D glasses 1900 may include a first oscillator 1910 and a second oscillator 1920, which form a quadrature oscillator, in frames of two lenses, respectively.

Accordingly, when power is supplied to the transmitting device 110, energy can be supplied via a wireless connection to the 3D glasses 1900 positioned within a predetermined distance from the transmitting device 110.

Referring to FIG. 20, the receiving device 120 may be implemented in a form of a headset 2000, e.g., a Bluetooth headset. A first oscillator 2010 and a second oscillator 2020, which form a quadrature oscillator, may be included in the headset 2000 as illustrated in FIG. 20.

Accordingly, when power is supplied to the transmitting device 110, energy can be supplied via a wireless connection to the headset 2000 positioned within a predetermined distance from the transmitting device 110.

Referring to FIG. 21, the receiving device 120 may be implemented in a form of a surround sound speaker system 2100. A first oscillator 2110 and a second oscillator 2120, which form a quadrature oscillator, may be included in the surround sound speaker 2100 as illustrated in FIG. 21.

Accordingly, when power is supplied to the transmitting device 110, energy can be supplied via a wireless connection to the surround sound speaker system 2100 positioned within a predetermined distance from the transmitting device 110.

13

The receiving device **120** is implemented in both speakers of the surround sound speaker system **2100**. Alternatively, the transmitting device **110** and the receiving device **120** may be implemented in the two speakers, respectively, of the surround sound speaker system **2100**. As another alternative, the transmitting device **110** may be implemented in the surround sound speaker system **2100** and may transmit wireless energy to the receiving device **120** positioned nearby.

FIG. **22** is a diagram of an electronic system **700** including the wireless energy receiving device **120** according to certain embodiments of the inventive concept. Referring to FIG. **22**, the electronic system **700** includes the wireless energy receiving device **120**, a system on chip (SoC) **710**, an antenna **701**, a radio frequency (RF) transceiver **703**, an input device **705**, a display **707**, and a power unit **709**.

The wireless energy receiving device **120**, which is a wireless energy receiving device according to certain embodiments of the inventive concept, receives wireless energy from a wireless energy transmitting device, and it generates and supplies reception power VR to the power unit **709**. The power unit **709** supplies internal power for the operations of the internal elements **703**, **705**, **707**, and **710** of the electronic system **700**.

The RF transceiver **703** transmits and receives RF signals through the antenna **701**. The RF transceiver **703** may convert an RF signal received through the antenna **701** into a signal that can be processed by the SoC **710**.

The SoC **710** processes the signal output from the RF transceiver **703** and transmits a processed signal to the display **707**. The RF transceiver **703** may also convert a signal output from the SoC **710** into an RF signal and outputs the RF signal through the antenna **701**. The SoC **710** may include a central processing unit (CPU) (not shown), which controls the overall operation of the electronic system **700**.

The input device **705** enables control signals for controlling the operation of the SoC **710** or data to be processed by the SoC **710** to be input to the electronic system **700**. The input device **705** may be implemented by a pointing device such as a touch pad or a computer mouse, a keypad, or a keyboard.

FIG. **23** is a diagram of an electronic system **800** including the wireless energy receiving device **120** according to other embodiments of the inventive concept. Referring to FIG. **23**, the electronic system **800** may be implemented as a personal computer (PC), a network server, a tablet PC, a netbook, an e-reader, a personal digital assistant (PDA), a portable multimedia player (PMP), an MP3 player, or an MP4 player.

The electronic system **800** includes the wireless energy receiving device **120**, a power unit **805**, a SoC **810**, a memory device **801**, a memory controller **802** controlling the data processing operations of the memory device **801**, a display **803**, and an input device **804**.

The wireless energy receiving device **120**, which is a wireless energy receiving device according to certain embodiments of the inventive concept, receives wireless energy from a wireless energy transmitting device, and it generates and supplies reception power VR to the power unit **805**. The power unit **805** supplies internal power for the operations of the internal elements **801**, **802**, **803**, **804**, and **810** of the electronic system **800**.

The SoC **810** may display data stored in the memory device **801** through the display **803** according to data input through the input device **804**. The input device **804** may be implemented by a pointing device such as a touch pad or a computer mouse, a keypad, or a keyboard. The SoC **810** may control the overall operation of the electronic system **800** and the opera-

14

tions of the memory controller **802**. For this control, the SoC **810** may include a CPU (not shown).

The memory controller **802**, which controls the operations of the memory device **801**, may be implemented as a part of the SoC **810** or as a chip separated from the SoC **810**.

FIG. **24** is a diagram of an electronic system **900** including the wireless energy receiving device **120** according to further embodiments of the inventive concept. Referring to FIG. **24**, the electronic system **900** may be implemented as an image processing device like a digital camera or a mobile phone equipped with a digital camera, a PDA, a PMP, or a smart phone.

The electronic system **900** includes the wireless energy receiving device **120**, a power unit **905**, a SoC **910**, a memory device **901**, and a memory controller **902** controlling the data processing operations of the memory device **901**. The electronic system **900** may also include an image sensor **903** and a display **904**.

The wireless energy receiving device **120**, which is a wireless energy receiving device according to certain embodiments of the inventive concept, receives wireless energy from a wireless energy transmitting device, and it generates and supplies reception power VR to the power unit **905**. The power unit **905** supplies internal power for the operations of the internal elements **901**, **902**, **903**, **904**, and **910** of the electronic system **900**.

The image sensor **903** converts optical images into digital signals and outputs the digital signals to the SoC **910** or the memory controller **902**. According to the control of the SoC **910**, the digital signals may be displayed through the display **904** or stored in the memory device **901** through the memory controller **902**.

Data stored in the memory device **901** may be displayed through the display **904** according to the control of the SoC **910** or the memory controller **902**. The memory controller **902**, which controls the operations of the memory device **901**, may be implemented as a part of the SoC **910** or as a chip separated from the SoC **910**. The SoC **910** may include a CPU (not shown) controlling the overall operation of the electronic system **900**.

FIGS. **25A** and **25B** are diagrams of an automobile **1100** including the wireless energy receiving device **120** according to certain embodiments of the inventive concept. Referring to FIGS. **25A** and **25B**, the automobile **1100** includes a wireless charge unit **1110**. The wireless charge unit **1110** may include the wireless energy receiving device **120** and a rechargeable battery **1112**.

The wireless energy receiving device **120**, which is a wireless energy receiving device according to certain embodiments of the inventive concept, receives wireless energy from a wireless energy transmitting device, and it generates and supplies reception power VR to the rechargeable battery **1112**.

For instance, while the automobile **1100** is parked in a parking lot, the rechargeable battery **1112** may be charged using a wireless energy transmission method according to certain embodiments of the inventive concept.

As described above, in a wireless energy receiving device, a wireless energy transmitting device, a wireless energy transmission system including both devices, and a wireless energy transmission method according to some embodiment of the inventive concept, a resonance frequency is tuned without directly adjusting an inductance value or a capacitance value, thereby realizing efficient wireless energy transmission.

While the inventive concept has been particularly shown and described with reference to embodiments thereof, it will be understood by those of ordinary skill in the art that various

15

changes in forms and details may be made therein without departing from the scope of the inventive concept as defined by the following claims.

What is claimed is:

1. In a wireless energy transmission system including a wireless energy receiving device and a wireless energy transmitting device, at least one of the wireless energy receiving device and the wireless energy transmitting device comprising:

a first oscillator configured to output an in-phase (I) signal; a second oscillator configured to output a quadrature-phase (Q) signal having a 90-degree phase difference from the I signal, wherein each of the first and second oscillators comprises a resonator having at least one inductor and at least one capacitor, and a current changing block connected to the at least one inductor and configured to change an amount of current flowing through the at least one inductor; and

a monitor configured to monitor a frequency of at least one of the I and Q signals and control the current changing block according to a monitoring result.

2. The wireless energy transmission system of claim 1, further comprising:

a sensor configured to sense a magnetic field between the wireless energy receiving device and the wireless energy transmitting device and further control the current changing block according to a sensing result.

3. The wireless energy transmission system of claim 1, wherein the resonator comprises:

a first inductor pair having first mutual inductance and including a first inductor and a second inductor; a second inductor pair having second mutual inductance and including a third inductor and a fourth inductor; a capacitor connected between the first inductor and the third inductor; and

a bias block configured to bias current flowing through the first and third inductors, wherein the current changing block changes current flowing through the second and fourth inductors.

4. The wireless energy transmission system of claim 3, wherein the least one inductor of the first oscillator is configured perpendicular to the at least one inductor of the second oscillator.

5. A wireless energy receiving device comprising: a first oscillator configured to output an in-phase (I) signal; and

a second oscillator configured to output a quadrature-phase (Q) signal having a 90-degree phase difference from the I signal,

wherein each of the first and second oscillators comprises: a first inductor pair having first mutual inductance and comprising a first inductor and a second inductor; a second inductor pair having second mutual inductance and comprising a third inductor and a fourth inductor; and

a capacitor connected between the first inductor and the third inductor,

wherein each of the first and second oscillators controls a magnitude of received wireless energy by changing a resonance frequency by changing an amount of current flowing through the second and fourth inductors.

6. The wireless energy receiving device of claim 5, wherein each of the first and second oscillators further comprises:

a current changing block configured to change the amount of current flowing through the second and fourth inductors.

16

7. The wireless energy receiving device of claim 5, wherein the first and third inductors have the same inductance, and the second and fourth inductors have the same inductance.

8. The wireless energy receiving device of claim 5, wherein each of the first and second oscillators further comprises:

a bias block configured to bias current flowing through the first and third inductors;

cross-coupled transistors respectively connected between the first inductor and the bias block, and between the third inductor and the bias block;

a transistor connected between the second inductor and the current changing block; and

a transistor connected between the fourth inductor and the current changing block.

9. The wireless energy receiving device of claim 8, wherein the Q signal output by the second oscillator is applied to gates of the transistors in the first oscillator, and the I signal output by the first oscillator is applied to gates of the transistors in the second oscillator.

10. The wireless energy receiving device of claim 5, wherein at least one of the inductors in the first oscillator is configured perpendicular to at least one of the inductors in the second oscillator.

11. An electronic system comprising:

a wireless energy receiving device configured to receive wireless energy from a wireless energy transmitting device through a magnetic field and generate reception power; and

a power unit configured to receive the reception power from the wireless energy receiving device and supply at least a portion of internal power necessary for operation of the electronic system,

wherein the wireless energy receiving device comprises:

a first oscillator configured to output an in-phase (I) signal; and

a second oscillator configured to output a quadrature-phase (Q) signal having a 90-degree phase difference from the I signal, and

each of the first and second oscillators comprises:

a resonator comprising at least one inductor and at least one capacitor; and

a current changing block connected to the at least one inductor to change an amount of current flowing through the at least one inductor.

12. The electronic system of claim 11, wherein each of the first and second oscillators further comprises:

a negative resistance block connected to the resonator to counterbalance positive resistance of the resonator; and

a coupling circuit block connected to the at least one inductor to couple the first and second oscillators.

13. The electronic system of claim 12, wherein the current changing block comprises at least two N-type metal oxide semiconductor (NMOS) transistors connected in parallel, a terminal of the at least two NMOS transistors being connected to the coupling circuit block, and the at least two NMOS transistors being selectively switched in response to an input control signal applied to gates of the respective at least two NMOS transistors to change the amount of current flowing through the at least one inductor.

14. The electronic system of claim 11, wherein the current changing block comprises:

a current source configured to supply a predetermined current;

a first N-type metal oxide semiconductor (NMOS) transistor having a terminal connected to the current source; and

17

at least two NMOS transistors connected to a gate of the first NMOS transistor as a current mirror, wherein the at least two NMOS transistors are selectively switched in response to an input control signal to change the amount of current flowing through the at least one inductor.

15. The electronic system of claim 11, wherein the current changing block comprises:

at least two current sources connected in parallel to supply a predetermined current;

a first N-type metal oxide semiconductor (NMOS) transistor having a terminal connected to the at least two current sources; and

a second NMOS transistor connected to a gate of the first NMOS transistor as a current mirror, wherein the at least two current sources are selectively switched in response to an input control signal to change the amount of current flowing through the at least one inductor.

16. The electronic system of claim 11, wherein the wireless energy receiving device further comprises:

a monitor configured to monitor a frequency of at least one of the I and Q signals and generate a control signal; and

a frequency adjustor configured to change the frequency of the I and Q signals by changing the amount of current flowing through the at least one inductor in response to the control signal.

17. The electronic system of claim 11, wherein the electronic system is one selected from the group consisting of a

18

smart phone, a mobile phone, a personal digital assistant (PDA), a portable multimedia player (PMP), and a tablet personal computer.

18. A method of receiving wireless energy using a wireless energy receiving device, the method comprising:

generating an in-phase (I) signal and a quadrature-phase (Q) signal having a 90-degree phase difference from the I signal using a quadrature oscillator comprising at least one pair of inductors having mutual inductance; and adjusting a resonance frequency by changing an amount of current flowing through one inductor in the at least one pair of inductors.

19. The wireless energy receiving method of claim 18, further comprising:

biasing current flowing in an inductor of the at least one pair of inductors using a predetermined bias current.

20. The wireless energy receiving method of claim 18, further comprising:

monitoring a frequency of at least one of the in-phase (I) signal and the quadrature-phase (Q) signal and providing a monitoring result, wherein the adjusting of the resonance frequency by changing the amount of current flowing through the inductor is made in response to the monitoring result.

* * * * *