

[72] Inventor **Ramon Balaguer Golobart**
Calle Valls y Taberner, 11, Barcelona,
Spain

[21] Appl. No. **756,146**

[22] Filed **Aug. 29, 1968**

[45] Patented **Mar. 16, 1971**

[32] Priority **Sept. 2, 1967**

[33] **Spain**

[31] **345,157**

[50] Field of Search..... 139/122,
127, 302

[56] **References Cited**
UNITED STATES PATENTS
3,276,482 10/1966 Liebchen..... 139/122W
Primary Examiner—Henry S. Jaudon
Attorney—Christen & Sabol

[54] **DEVICE FOR PRESENTING AND CUTTING THE
SELECTED WEFT THREADS IN STATIONARY
WEFT LOOMS**
6 Claims, 8 Drawing Figs.

[52] U.S. Cl..... 139/122,
139/302

[51] Int. Cl..... D03d 47/36

ABSTRACT: Apparatus for presenting weft yarns to the inserting element of a loom comprises a first assembly which reciprocates about a vertical axis and a second assembly which rotates unidirectionally about another vertical axis, each of the assemblies having one of two coacting cutting elements which cut the yarns after presentation to the inserting element, while the first assembly also includes an arm which presents the yarns to the inserter and also positions them to be cut by the two cutting elements.

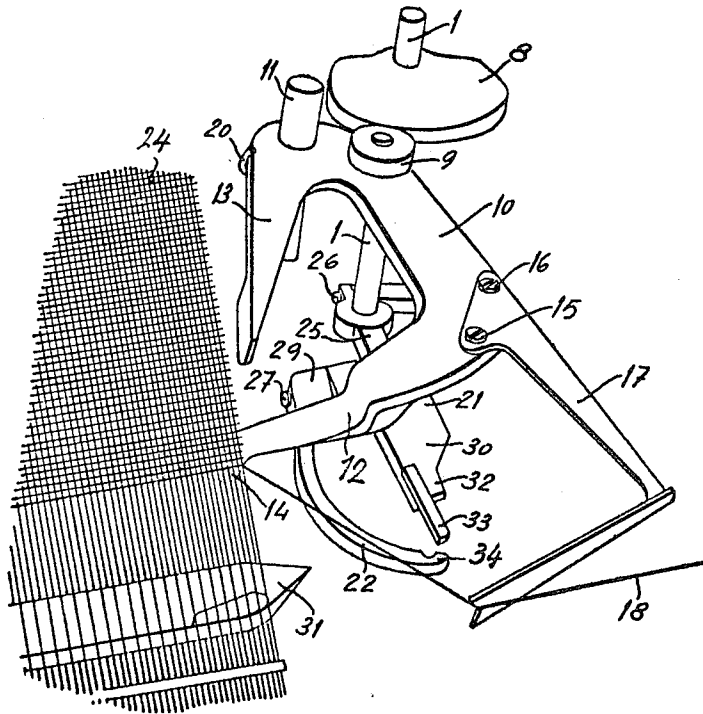

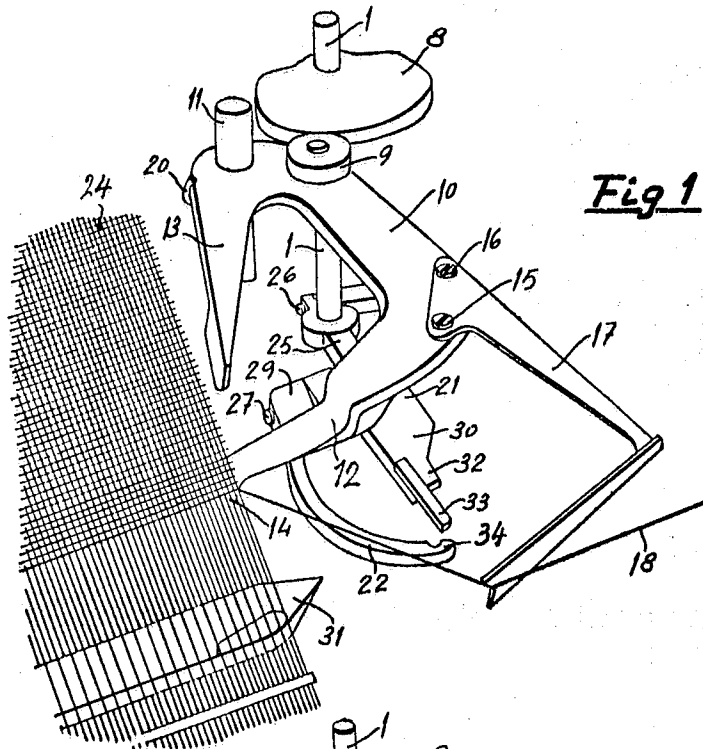

Fig 1

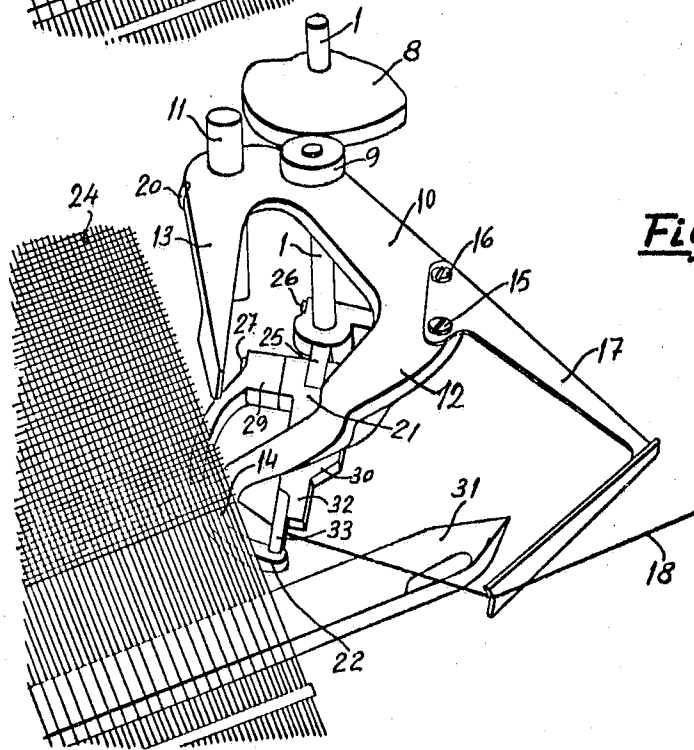

Fig 2

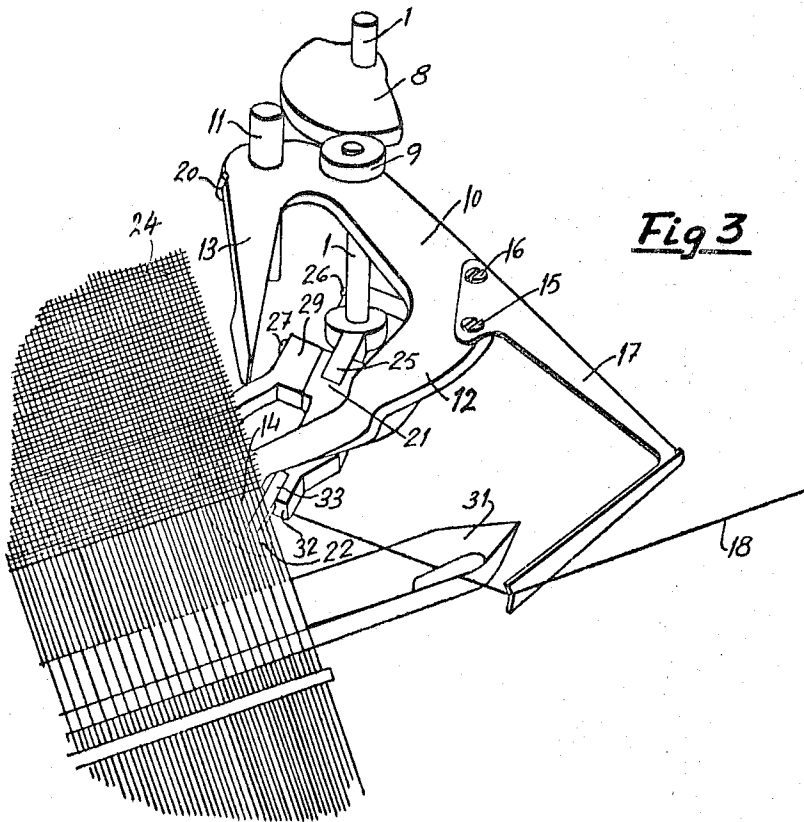

Fig 3

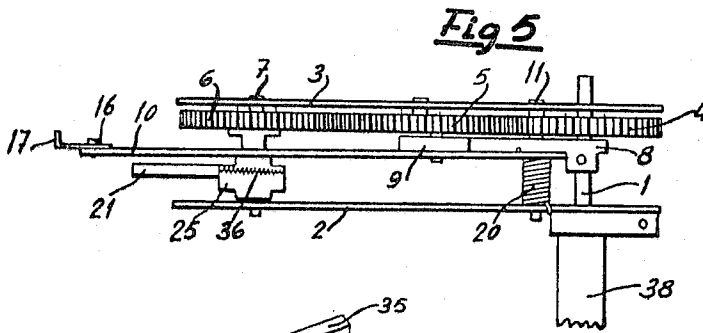

Fig 5

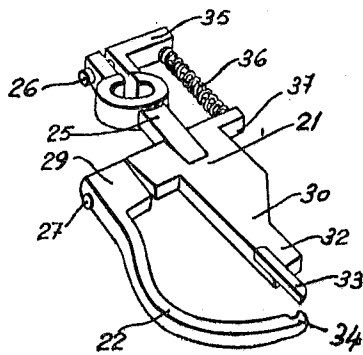

Fig 4

Fig 6

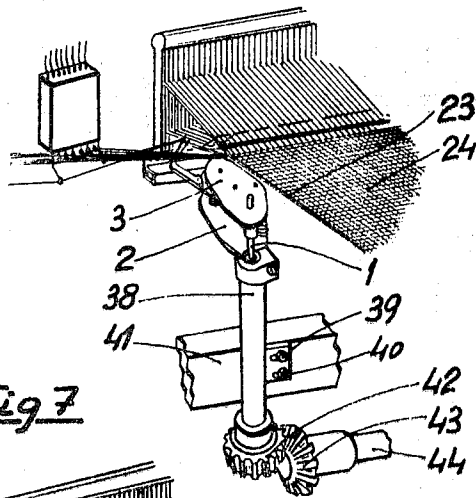

Fig 7

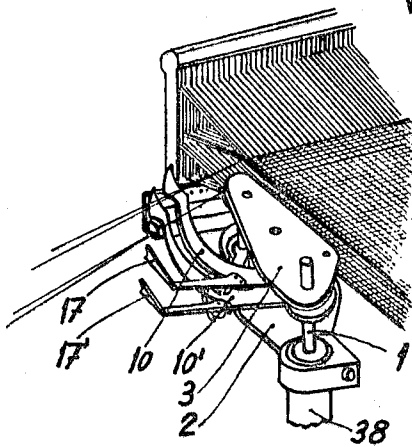
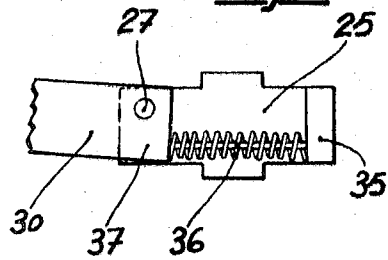

Fig 8



DEVICE FOR PRESENTING AND CUTTING THE SELECTED WEFT THREADS IN STATIONARY WEFT LOOMS

The present invention refers to a device for presenting and cutting the filling yarns selected in looms with fixed weft reserve, and more particularly to a device in which the operations of presenting and cutting of the selected filling yarns are effected simultaneously by said device.

There are several types of devices for presenting the filling yarns to the inserting member in looms with fixed weft supply, which are based generally on using hooks which pickup the yarns selected by a selecting device and presenting them, through a vertical or horizontal turn, to the inserting member; the addition of a separate device to cut the filling yarns is also required, and the two devices must be perfectly synchronized in the combination of their motions to effect these operations properly.

Similarly, there are various types of devices for the cutting of the weft yarns. The most usual ones comprise scissors, knives or other cutting elements, all of them actuated separately of the presenting elements, but still requiring a perfect synchronism between the cutting devices and the presenting elements. This causes mechanical complications, and the risk of one element interfering with the other, unless the adjustment is perfect; they also require double control means, which must also be synchronized with the inserting member, thus requiring double adjustment.

The device which is the object of the present invention solves all of these disadvantages, since the device fulfills both functions of presenting the filling yarns selected to the inserting member and of cutting the selected filling yarns at the edge of the fabric, without running the risk of the two mechanisms interfering with each other, since they operate under the same controls, thus eliminating completely all adjusting and regulating operations, and carrying out the motions in perfect synchronization of positions in the whole operating cycle with respect to the inserting member.

The device which is the object of the present invention comprises two parallel support plates; an upper one and a lower one, which support between them a mechanism actuated by a vertical shaft which is driven rotationally by a suitable shaft of the loom. This vertical rotating shaft crosses the lower support plate, and its free upper extremity, which crosses and is supported on the upper support plate, carries a first gear wheel which transmits a rotating motion to a second gear wheel, and the latter to a third gear wheel affixed on a second vertical shaft supported at its extremities on said support plates, upper and lower. The first vertical shaft which moves rotatively carries a cam, which slidably engages with a roller connected with a first element for the presenting and cutting of the selected weft yarns, which is hinged rotatably in both support plates and comprises an arm which presents said selected weft yarns to the inserting member, and a sharp appendage which serves as a cutting knife and forms a part of the cutting member for the selected weft yarns of the edge of the fabric, the unit being imparted an arcuate oscillating motion because of the shape of said cam.

The second rotating vertical shaft, which carries the third gear wheel, also carries a second presenting-cutting element for the selected weft yarns, which is composed of an arm presenting the selected weft yarns to the cutting member at the border of the fabric of said yarns, and a cutting knife, which forms a part of said cutting member; the whole unit having an uninterrupted rotating motion in a clockwise direction.

For better understanding of the invention, one embodiment, given as a nonlimiting example only, is described hereinafter, with reference to the attached drawings.

FIGS. 1, 2 and 3 are perspective views of the first and second presenting-cutting elements listing various stages in an operation of inserting and cutting of a weft thread.

FIG. 4 is a perspective view of one of the second presenting elements listing details of its construction.

FIG. 5 is a side view of one set of presenting-cutting elements. FIG. 6 is a perspective view of the device showing its relative position on the feeding side of the loom.

FIG. 7 is a perspective view of a modification of the invention for the presenting and cutting of the selected weft yarns on a loom with fixed weft supply which manufactures two parallel fabrics at the same time.

FIG. 8 is a detail view of the actuation of the spring of the presenting arm and cutting knife of the second presenting-cutting element.

In these FIGS. the unit as a whole is supported on a vertical hollow pedestal 38 affixed to the cross rail 41 of a loom by means of screws 39 and 40. Within the pedestal there is rotatably mounted a vertical shaft 1, having a bevel pinion 42 at its lower end which meshes with bevel pinion 43 attached to the end of a rotating shaft 44 of the loom, as shown in FIG. 6. The upper end of the pedestal 38 supports a lower horizontal support plate 2 and an upper support plate 3 is mounted above the lower plate in horizontal vertically spaced relationship. The upper of shaft 1 carries a first gear wheel 4, positioned between the two support plates, which meshes with a second gear wheel 5, carried on a shaft attached to plate 3 which, in turn, meshes with a third gear wheel 6 affixed to a second vertical shaft 7 mounted between the support plates 2 and 3.

A first presenting-cutting element 10, having two convergently directed horizontally spaced appendages 12 and 13, is mounted on a vertical shaft 11 extending between the support plates 2 and 3. Appendage 12 terminates in a flat nose-shaped portion 14 which is sharpened to form a cutting knife and an L-shaped arm 17 is attached at one end by screws 15 and 16 to the area of the element 10 between the bases of the appendages 12 and 13. A coil spring 20 surrounds shaft 11, one end of the spring being secured to the support plate 2 while the other end is attached to the presenting-cutting element 10 to urge the element towards its initial and retracted position, this initial position being determined by the extremity of the appendage 13 which abuts against a fixed stop (not shown). Shaft 1 also carries a cam 8 having an eccentric peripheral surface which engages with a follower, or roller, 9 attached to element 10 so that rotation of the cam by shaft 1 will move the present-cutting element 10 from its initial position to the position shown in FIGS. 1—3 against the force of coil spring 20 during a portion of each revolution thereof, the spring returning the element 10 during the remainder of the cycle.

A second presenting-cutting element 21 is mounted on the lower end of shaft 7 for continuous unidirectional rotation as a result of the rotation of shaft 7 by shaft 1 through the meshing gears 4, 5 and 6. The mounting for element 21 includes a support 25 affixed to the shaft 7 by means of a clamping screw 26. Support 25 carries a horizontal fixed shaft 27, the extremities of this shaft projecting outwardly of the support 25 to provide a fixed mounting for a winglike member 29 and a pivotal mounting for a second winglike member 30. A presenting arm 22 is attached to wing 29, while a cutting element 33 is placed on the extremity 32 of wing 30. The arm 22 includes a curved extremity 34 spaced from the cutting element 33 to provide a space for the introduction of selected weft yarns 18. The support 25, as seen in FIG. 8 has a projection 35 against which is applied one end of a coil spring 36, the other extremity of the spring abutting against a depending portion 37 of wing 30 to urge the cutting element 33 in an upward direction.

The operation is as follows:

The vertical shaft 1 to which is imparted a rotating motion transmitted by the bevel pinion 42 (FIG. 6), geared with the bevel pinion 43 applied to a shaft 44 of a loom, transmits rotating motion to the first gear wheel 4 (FIG. 5), which, in turn rotates the second gear wheel 5, the third gear wheel 6 and, finally, the second vertical shaft 7. Vertical shaft 1 also imparts a rotating motion to cam 8, which upon rotating in contact with roller 9, moves in an arc the whole assembly of the first presenting-cutting element 10 (FIG. 2), composed of the presenting arm 17 and the sharp extremity 14 which serves as a cutting knife.

Simultaneously with this arcuate movement of the first presenting-cutting element 10 which brings the presenting arm 17 and cutting knife 14 closer to the edge 23 of the fabric 24, the second presenting-cutting element 21 affixed to the second vertical shaft 7 advances, so that arm 22 of said second presenting-cutting element 21 moves beyond the position of presenting arm 17 of the first presenting-cutting element 10, said presenting arm 22 of the second presenting-cutting element 21 (FIG. 2) making the contact with the selected weft yarns 18. Upon continuation of its rotary advance, the fork-shaped extremity of L-shaped arm 17 has positioned said selected weft yarns 18 so as to move into the space between arm 22 and cutting element 33 (FIG. 1) in cutting position at the edge 23 of the fabric 24 (FIG. 3), so that once they are placed in the position shown in FIG. 2 by the presenting arm 17 of the first presenting-cutting element 10 and the presenting arm 22 of the second presenting-cutting element 21, they are picked up by said inserting member 31 and simultaneously the cutting of these weft yarns 18 and 19 is effected through the contact of the cutting knife 33 of the second presenting-cutting element 21 during its rotary motion, with the sharpened extremity 14 of appendage 12 of the first presenting-cutting element 10, the two knives 14 and 33 which form the cutting member, acting as scissors. This results from the application of force by the coil spring 36 on the depending portion 37 (FIG. 8) which produces an upward tilting of the cutting knife 33, causing a slight contact of the two knives 14 and 33 to effect the cutting.

Once the cutting is effected, the second presenting-cutting element continues its uninterrupted rotation, guided by appendage 13 of the first presenting-cutting element 10, and simultaneously, said first presenting-cutting element 10 effects its return movement to its initial position resulting from the configuration of cam 8 and the pressure of coil spring 20.

In the case in which a loom having fixed weft supplies has two parallel inserting members, the application of a device with a double set of presenting-cutting elements is extremely simple, in view of the small vertical space required by the unit, as can be seen clearly in FIG. 7, which shows a modified form of device in which the arms 17 and 17' of the two first presenting-cutting elements 10 and 10' are in the position corresponding to the device shown in FIG. 1, as are all the other component elements of the device.

Other changes and improvements may be made in the invention which would come within the scope of the annexed claims.

I claim:

1. An apparatus for presenting and cutting yarns for a loom of the type having a fixed weft supply, a reciprocatory weft inserting device and including a rotary driven element, comprising first and second presenting-cutting means, means for mounting said two presenting-cutting means on the frame of a loom for rotary movement about horizontally spaced respective vertical axes, means for imparting oscillatory rotary movement to the first presenting-cutting means in timed relationship between said two rotary movements, said first presenting-cutting means for presenting yarn from a weft supply to an inserting means and also including a knife element, said second presenting-cutting means including another knife element, and means for engaging said two knife elements one with another during said rotary movement for severing a yarn.

2. Apparatus as defined in claim 1 wherein said apparatus includes support means for mounting a pair of horizontally spaced shafts, means for drivingly connecting both said shafts with the rotary driven element of a loom, said second presenting-cutting means being attached to one of said pair of shafts, said first presenting-cutting means being mounted on said support means, and camming means attached to one of said shafts for imparting said oscillatory movement to the first presenting-cutting means.

3. Apparatus as defined in claim 2 wherein said first presenting-cutting means includes a base portion having a pair of spaced convergent appendages, one of said appendages including said knife element, the other of the appendages serving as a guide for the knife element of the second presenting-cutting means, said base portion also carrying a follower element coacting with said camming means and a projecting arm for presenting weft yarns.

4. Apparatus as defined in claim 2, wherein said second presenting-cutting means includes a base portion mounted on one of said shafts, and a member pivotally mounted on said base portion for oscillatory movement about a horizontal axis, said knife element and means for presenting weft yarns being attached to said oscillatory mounted member.

5. Apparatus as defined in claim 2, wherein said means for imparting oscillatory movement to the first presenting-cutting means includes cam follower means for abutting engagement with said camming means, and coil spring means for urging said abutting engagement.

6. Apparatus as defined in claim 4, wherein said oscillatory mounted member is provided with spring means for urging the knife element on said member into operative engagement with the knife element of the first presenting-cutting means.

50

55

60

65

70

75