

(19) World Intellectual Property Organization
International Bureau



(43) International Publication Date
10 December 2009 (10.12.2009)

(10) International Publication Number
WO 2009/148448 A1

(51) International Patent Classification:
B41J 2/05 (2006.01) *B41J 2/01* (2006.01)

(21) International Application Number:
PCT/US2008/065872

(22) International Filing Date:
5 June 2008 (05.06.2008)

(25) Filing Language: English

(26) Publication Language: English

(71) Applicant (for all designated States except US):
HEWLETT-PACKARD DEVELOPMENT COMPANY, L.P. [US/US]; 11445 Compaq Center Drive West, Houston, TX 77070 (US).

(72) Inventors; and

(75) Inventors/Applicants (for US only): **SABO, David** [US/US]; 16399 W Bernardo Dr., San Diego, California 92127-1899 (US). **KOROL, Evgeny** [IL/US]; 16399 W Bernardo Dr., San Diego, California 92127-1899 (US).

(74) Agents: **WASSON, Robert D.** et al.; Hewlett-Packard Company, Intellectual Property Administration, Mail Stop 35, P.O. Box 272400, Fort Collins, Colorado 80527-2400 (US).

(81) Designated States (unless otherwise indicated, for every kind of national protection available): AE, AG, AL, AM, AO, AT, AU, AZ, BA, BB, BG, BH, BR, BW, BY, BZ, CA, CH, CN, CO, CR, CU, CZ, DE, DK, DM, DO, DZ, EC, EE, EG, ES, FI, GB, GD, GE, GH, GM, GT, HN, HR, HU, ID, IL, IN, IS, JP, KE, KG, KM, KN, KP, KR, KZ, LA, LC, LK, LR, LS, LT, LU, LY, MA, MD, ME, MG, MK, MN, MW, MX, MY, MZ, NA, NG, NI, NO, NZ, OM, PG, PH, PL, PT, RO, RS, RU, SC, SD, SE, SG, SK, SL, SM, SV, SY, TJ, TM, TN, TR, TT, TZ, UA, UG, US, UZ, VC, VN, ZA, ZM, ZW.

(84) Designated States (unless otherwise indicated, for every kind of regional protection available): ARIPO (BW, GH, GM, KE, LS, MW, MZ, NA, SD, SL, SZ, TZ, UG, ZM, ZW), Eurasian (AM, AZ, BY, KG, KZ, MD, RU, TJ, TM), European (AT, BE, BG, CH, CY, CZ, DE, DK, EE, ES, FI, FR, GB, GR, HR, HU, IE, IS, IT, LT, LU, LV,

[Continued on next page]

(54) Title: REDUCING INK DROPLETS GENERATED BY BURSTING BUBBLES IN AN INK DEVELOPER

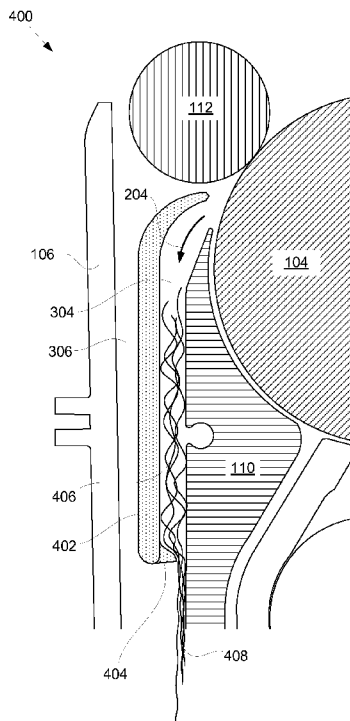

Fig. 4

(57) Abstract: An apparatus for reducing ink droplets (310) generated by bursting bubbles (300) within an ink developer (100, 400) includes a surface directing an ink flow (204, 206) into a channel (304); and a protrusion (404) within the channel (304) that reduces ink droplets (310) generated by bursting bubbles (300) entrained within the ink flow (204, 206). An ink developer (100, 400) includes an ink source (120) supplying ink (202) to the ink developer (100, 400); an electrode (110) which develops a portion of the ink (202) onto a developer roller (104); and a splash guard (402, 500) which directs an undeveloped ink flow (204, 206) into a channel (304) which has a reduced cross-section area configured to reduce bubbles (300) exiting the channel (304) and bursting.

WO 2009/148448 A1

MC, MT, NL, NO, PL, PT, RO, SE, SI, SK, TR), OAPI
(BF, BJ, CF, CG, CI, CM, GA, GN, GQ, GW, ML, MR,
NE, SN, TD, TG).

— *as to applicant's entitlement to apply for and be granted
a patent (Rule 4.17(ii))*

Declarations under Rule 4.17:

— *as to the identity of the inventor (Rule 4.17(i))*

Published:

— *with international search report (Art. 21(3))*

Reducing Ink Droplets Generated by Bursting Bubbles in an Ink Developer

5

BACKGROUND

10 **[0001]** In printing devices that utilize ink, air bubbles can become entrained in ink flows within the device. When these air bubbles burst, ink droplets are ejected. These ink droplets can create print quality defects and contribute to the accumulation of concentrated ink (or sludge) that can block or limit the flow of ink, which in turn can result in malfunctions and customer
15 dissatisfaction.

BRIEF DESCRIPTION OF THE DRAWINGS

20 **[0002]** The accompanying drawings illustrate various embodiments of the principles described herein and are a part of the specification. The illustrated embodiments are merely examples and do not limit the scope of the claims.

[0003] Fig. 1 shows one illustrative embodiment of an ink developer device, according to principles described herein.

25 **[0004]** Fig. 2 shows the flow of ink in an ink developer device, according to principles described herein.

[0005] Figs. 3A, 3B, and 3C show a time sequence in which a bubble bursts inside an ink developer device, creating ink droplets that are dispersed out of the ink developer device, according to principles described herein.

30 **[0006]** Fig. 4 s a cross-sectional diagram of an illustrative ink developer device containing an illustrative splash guard, according to principles described herein.

[0007] Fig. 5 is a side view of an illustrative splash guard, according to principles described herein.

[0008] Fig. 6 is a perspective view of an illustrative splash guard, according to principles described herein.

5 **[0009]** Throughout the drawings, identical reference numbers designate similar, but not necessarily identical, elements.

DETAILED DESCRIPTION

10 **[0010]** In the following description, for purposes of explanation, numerous specific details are set forth in order to provide a thorough understanding of the present systems and methods. It will be apparent, however, to one skilled in the art that the present apparatus, systems and methods may be practiced without these specific details. Reference in the
15 specification to “an embodiment,” “an example” or similar language means that a particular feature, structure, or characteristic described in connection with the embodiment or example is included in at least that one embodiment, but not necessarily in other embodiments. The various instances of the phrase “in one embodiment” or similar phrases in various places in the specification are not
20 necessarily all referring to the same embodiment.

[0011] Fig. 1 shows a side view of one exemplary embodiment of an ink developer device (100). The ink developer device (100) may be utilized in liquid electro photography (LEP) printers. Furthermore, the ink developer device (100) may be a binary ink developer (BID) unit.

25 **[0012]** One of the purposes of the ink developer device (100) is to present a uniform film of ink to a photo-conductive drum (102). To do this, the device (100) utilizes a continuous flow of ink that enters through the inlet port (120), travels through the device to where a small portion of the ink is transferred to the photo-conductive drum (102), with the majority of the ink
30 exiting the device (100) through the ink outlet (108). This non-developed ink returns to an ink reservoir where it is reconditioned and re-circulated into the ink developer device (100) through the inlet port (120).

[0013] The ink includes a fluid carrier and ink particles. The ink particles are suspended in the fluid carrier, which allows the ink particles to be easily transported, stored, and manipulated. The ink particles are influenced by the presence of electromagnetic fields, while the fluid carrier is not.

5 **[0014]** The device (100) includes an ink developer roller (104) that is configured to supply a uniform film of ink that is then selectively transferred to the photoconductive drum (102). To selectively transfer the ink, a charge pattern that corresponds to the image being printed is generated on the photoconductive drum (102) by a laser. Ink on the outer surface of the
10 developer roller (104) is transferred to the charged portions of the photoconductive drum (102). This creates a liquid ink pattern that is then transferred from the photoconductive drum (102) to a print medium such as paper or to an intermediate transfer member to form the desired image on the print medium.

15 **[0015]** The device (100) also includes an ink tray (106) to contain the ink flow and direct any non-developed ink to an ink outlet (108). A main electrode (110) and a developer roller are electrically charged to manipulate the ink particles. Additionally, the gap between the main electrode (110) and the developer roller (104) creates a channel through which the ink is conveyed by
20 the viscous action of the rotating drum (104). The main electrode also supports the various parts of the device (100).

[0016] A squeegee roller (112) compacts the ink film on the developer roller and removes any non-developed ink to create a uniform film of ink on developer roller (104). The outer surface of the developer roller (104) is initially
25 coated with a relatively thick layer of ink as it comes in contact with ink that is pumped into the device through the ink inlet (120). Due to the electrostatic field generated by the electrical potential between the main electrode (110) and the developer roller (104), the ink particles preferentially adhere to the developer roller (104), thereby creating a high solid content ink film on the surface of the
30 developer roller (104). The squeegee roller (112) compacts this high solid content ink film and knocks down the non-developed lower solid content ink.

[0017] Droplets exiting the ink tray (106) can cause an ink developer device to fail in at least three ways: cross-contamination, print quality issues, and customer dissatisfaction. Cross-contamination occurs when droplets from one binary ink developer impact an adjacent binary ink developer and
5 contaminate its ink supplies. Print quality issues occur when droplets reach the photo imaging plate and appear as print quality defects on the printed page. Additionally, droplets can build up deposits of sludge inside or outside of the device. Sludge deposits can limit the actual or perceived lifetime of the device. External splashes build up on the outside of the binary ink developer as an
10 unsightly accumulation of sludge. This can impact the total customer experience and prompts users to prematurely replace the binary ink developer.

[0018] Other components of the device (100) may include: a cleaning roller (114) to clean the developer roller (104); a wiper blade (126) to scrape
15 excess ink from the cleaning roller (114); a sponge roller (116) to clean excess ink from the wiper blade (126) and/or cleaning roller (114); and a squeezer roller (118) to wring excess ink out of the sponge roller (116). The sponge roller (116) may come in contact with the wiper blade (126) and/or the cleaning roller (114) to clean one or both of them. An ink inlet (120) introduces fresh or recycled ink to the binary ink developer (100). Additionally, the binary ink developer (100)
20 contains an ink drain passage (124) to allow the drainage of excess ink from the upper area of the ink developer (100).

[0019] Fig. 2 illustrates an exemplary flow of ink in an ink developer device (100) according to one embodiment. As previously mentioned, the device (100) includes the ink developer roller (104), ink tray (106), ink outlet
25 (108), main electrode (110), squeegee roller (112), cleaning roller (114), sponge roller (116), squeezer roller (118), ink inlet (120), ink drain passage (124), and wiper (126). The arrows inside each roller indicate the exemplary rotational direction of the respective roller. For example, several rollers (102, 112, 114, and 116) are shown to rotate in a counter-clockwise direction, whereas other
30 rollers (104, 118) are shown to rotate in a clockwise direction.

[0020] As illustrated in Fig. 2 by the ink flow arrows (202), the device (100) receives fresh (or recycled) ink from the ink supply through the ink inlet

(120). This ink travels upward and enters the channel between the main electrode (110) and the developer roller (104). The electrical potential bias between the main electrode (100) and the developer roller (104) causes ink particles to preferentially adhere to surface of the developer roller (104). The squeegee roller (112) regulates the ink film thickness on the developer roller (104). Ink is selectively transferred from the developer roller (104) to the charged portions of the photoconductive drum surface (102).

[0021] In one implementation, to provide printing performance and to optimize the ink circulation through the device with a minimum build up of sludge, the device (100) utilizes a variety of cleaning parts (such as 114, 116, and 118). The cleaning roller (114) removes leftover ink from the developer roller (104). The wiper blade (126) cleans the cleaning roller (114). The sponge roller (116) removes ink from the wiper blade (126) and/or cleaner roller (114). The squeezer roller (118) wrings the accumulated ink from the sponge roller (116).

[0022] As illustrated in Fig. 2, ink that is not transferred to the photoconductive drum returns via the ink outlet (108) to the ink reservoir to be reconditioned and re-circulated. There are three channels through which the ink can travel to reach the ink outlet (108). First, the excess ink that is wrung out of the sponge roller (116) by the squeezer roller (118) can exit the ink drain passage (124). Excess ink may also travel down the channels between the internal mechanisms and the front or rear walls of the ink tray (106). In particular, ink that is dislodged by the squeegee roller (112) passes between the main electrode (110) and the rear wall of the ink tray (106).

[0023] A splash guard (128) is used as a method to control splashes produced by the squeegee roller (112) as it compacts the ink film on the outer surface of the developer roller (104). The splash guard (128) can be attached to the main electrode (110) and/or the ink tray (106) by spacers that maintain the desired distance between the splash guard (128) and the surrounding components. The spacers create channels for the ink that is dislodged by the squeegee roller (112) to return to the bottom of the ink tray (106) and exit through the ink outlet (108).

[0024] The splash guard (128) is configured to split the flow of non-developed ink dislodged by the squeegee roller (112) into two separate streams. The majority of the ink (204) dislodged by the squeegee roller (112) is deflected downward by the splash guard (128) and passes between the main electrode (110) and the front surface of splash guard (128). A lesser, but still significant, portion of the ink (206) passes between the squeegee roller (112) and the outside splash guard surface. This second flow of ink (206) is sufficient to maintain a steady stream of ink down the back of the splash guard (128) and toward the ink outlet (108, FIG. 2), but does not typically fill the channel between the rear of the splash guard (128) and the housing (106).

[0025] Figs. 3A, 3B, and 3C show a time sequence in which a bubble (300) bursts inside an ink developer device (100) creating ink droplets (310) that are dispersed out of the ink developer device (100). Fig. 3A is a cross-sectional diagram of a portion of an ink developer device (100) showing the developer roller (104), ink tray (106), main electrode (110), squeegee roller (112), and a splash guard (128). As previously described, the ink dislodged by the squeegee roller (112) is split into two streams, a principal stream (204) which passes through the main channel and a secondary stream (206) which passes behind the splash guard (128).

[0026] Bubbles (300) can form in at least two different ways within the principal stream (204). In some circumstances, small bubbles may be entrained in the principal stream (204) as it enters the main channel between the splash guard (128) and the main electrode (110). These small bubbles coalesce into a larger bubble (300) which may remain trapped in the main channel for a period of time. In one embodiment, the fluid flow within the main channel is primarily turbulent in nature, which contributes to the entrainment of air into the ink flow (204). The second way that bubbles may enter the main channel is to enter from the bottom. In circumstances when the principal stream (204) does not substantially fill the main channel (304), air from the bottom of the main channel (304) may rise into the main channel (304) and become trapped by ink.

[0027] Fig. 3B shows the bubble (300) exiting the main channel. The bubble (300) may grow large enough to be pushed out of the main channel by fluid forces. As the bubble (300) exits the main channel, it is no longer surrounded by fluid or constraining walls.

5 **[0028]** Fig. 3C shows the bubble (300) bursting. The bubble (300) may burst for a variety of reasons including pressure differences between the main channel and the larger cross-sectional area of the ink tray (106). As the bubble (300) bursts, ink droplets (310) are ejected. These ink droplets (310) may exit out the secondary channel or through other routes to the surrounding
10 area.

[0029] As the ink droplets (310) exit, they may contact various surfaces. A portion of the ink droplets (310) may adhere to a dry surface, such as the inner or outer surface of the ink tray (106). The carrier fluid in these droplets evaporates, leaving the ink particulates on the surface. Over time,
15 these ink particulates accumulate and form sludge which can interfere with the proper operation of the ink developer. By way of example and not limitation, the ink droplets (310) may eventually fill the secondary channel (306) causing the secondary flow (206) to overflow and exit the ink tray. This overflow can cause a variety of problems including cross contamination, image defects, stains, and
20 cause other customer quality issues.

[0030] Additionally, if the ink droplets contact the outside of ink tray, an unsightly accumulation of sludge may develop on the exterior of the ink tray (106) prompting the customer to prematurely replace the ink developer. Moreover, when an ink droplet (310) contacts a photo conductive drum (see
25 e.g. 102, Fig. 1), it can be transferred to the printing medium and be manifest as a printing defect. In some cases, the ink droplets (310) may contact the printing medium itself.

[0031] Fig. 4 shows a cross-sectional diagram of an illustrative ink developer device (400) which includes the ink developer roller (104), the squeegee roller (112), ink tray (106) and main electrode (110). The ink developer device (400) utilizes a splash guard (402) to prevent the formation and bursting of bubbles as described above. The splash guard (402) has a
30

protrusion (404) along its bottom edge. The protrusion (404) shapes the principal ink flow (204) as it passes through the main channel (304). In some circumstances, the principal ink flow (204) may have a region of turbulent flow (406) as it passes through the main channel (304). The turbulent flow (406) region is characterized by increased stochastic property changes such as high momentum convection and variations of pressure and velocity in both space and time. This turbulent flow (406) normally exists throughout the main channel (304) and allows air bubbles to become trapped in the principal ink flow (204). In other cases, the principal ink flow (204) does not entirely fill the main channel (304). Air fills the balance of the main channel (304). This air is occasionally encircled by the principal ink flow (204) and swept out of the principal channel as an air bubble. As previously discussed, when these air bubbles eventually exit the main channel (304), the bubbles burst thereby dispersing ink droplets at relatively high velocities.

[0032] The protrusion (404) reduces the cross-sectional area of the main channel (304) and directs the principal ink flow (204) toward the main electrode wall as it exits from the main channel (304). This reduced cross-section in the principal ink flow can reduce the number of bubbles exiting and bursting in a number of ways. First, it is much more difficult for the air to enter the principal channel (304) through the channel's lower end because the flow restriction created by the protrusion (404) creates a fluid seal between the splash guard (402) and the electrode wall. Second, the protrusion (404) may prevent the bubbles which do become trapped in principal ink flow (204) from exiting. Third, the acceleration of the fluid as it passes through the constriction may lower the fluid pressure to more closely approximate that of the interior of the ink tray (106). If the pressure inside the bubble is approximately equal to the surrounding pressure, the bubble may burst much less energetically. Fourth, the protrusion (404) may force the bubbles to burst earlier in the fluid flow. In one illustrative embodiment, bubbles which burst as they are exiting through the flow constriction created by the protrusion (404) are much more benign.

[0033] In one exemplary embodiment, the protrusion (404) forces the principal ink flow (204) into contact with the main electrode (110). Surface

tension forces tend to bind the principal ink flow (204) to the main electrode surface, resulting in a laminar flow region (408) as the principal ink flow (204) exits the main channel (304) and continues to travel downward. The laminar flow region (408) inhibits undesirable bubble bursting by allowing for an orderly
5 escape of trapped air. Further, laminar flow reduces the introduction of additional air into the fluid flow, thereby reducing bubbles and foaming. In one exemplary embodiment, the air in the ink is separated from the ink as it passes through the reduced cross-section area produced by the protrusion (404). The principal ink flow (204) is adhered to the electrode wall and the air is allowed to
10 escape into the interior of the ink tray (106).

[0034] Multiple ink developer devices may be utilized in a single printer. Each ink developer device may be in a different orientation within the printer. Therefore, the splash guard (402) and surrounding components should work throughout the normal range of orientations. Because the roller motion
15 and surface tension are the principal drivers of the fluid flow within the ink developer, the fluid flow through the principal channel (304) and subsequent laminar flow (408) remain substantially unaffected by moderate changes in orientation of the ink developer device with respect to a downward gravity vector.

[0035] Fig. 5 is a side view of one illustrative embodiment of a splash guard (500) for use in a binary ink developer. According to one exemplary embodiment, the splash guard (500) comprises a body portion (514) which terminates in an upper curved tip (512). The splash guard (500) may further
20 comprise a secondary spacer (502) and a principal spacer (504). The spacers (502, 504) are configured to maintain the desired distances between the splash guard (500) and the surrounding components. For example, the principal spacer (504) may interface with the main electrode (110) to maintain the appropriate principal channel (304, Fig. 4) spacing.

[0036] The spacers (502, 504) may also incorporate alignment
30 features. According to one exemplary embodiment, the principal spacer (504) may have a conical projection (506) designed to interface with a matching orifice in the main electrode (110). It will be appreciated by those of skill in the

art that the projection (506) provides only one of many possible methods of aligning the splash guard (500).

[0037] The splash guard (500) may further comprise a protrusion (516) along its lower edge. The protrusion (516) may comprise a curved upper profile (508) that terminates in a sharp corner (510). According to one exemplary embodiment, the curved upper profile (508) is configured to direct the principal ink flow (204, Fig. 2) toward the electrode wall and the sharp corner (510) is configured to promote the separation of air out of the principal ink flow (204, Fig. 2).

[0038] Fig. 6 shows a perspective view of one exemplary embodiment of a splash guard (500). The body (514) of the splash guard (500) is substantially rectangular, with the top edge curving inward to form an upper curved tip (512). The protrusion (516) extends along at least a portion of the lower edge of the splash guard body (514). According to one exemplary embodiment, the protrusion (516) may not extend across portions of the lower edge at either end of the splash guard (500).

[0039] Principal spacers (504) are shown at even intervals along the side of the splash guard (500) and are designed to maintain the desired distance between the guard and the main electrode (110, Fig. 4). In this embodiment, the principal spacers (504) do not contain an alignment feature (506, Fig. 5). Instead, a number of elongated orifices (600, 602) in the splash guard body (514) are configured to receive fasteners, such as screws, that will hold the splash guard (500) in place.

[0040] A variety of methods could be used to precisely position the splash guard (500) with respect to the other components prior fixing the splash guard (500) in position using the fasteners. By way of example and not limitation, an alignment fixture could be inserted between the splash guard (500) and the rollers (104, 112) to precisely define the position of the splash guard tip (512) and the bottom protrusion (516). The fasteners could then be tightened to fix the splash guard (500) in position. Following the tightening of the fasteners, the fixture is removed.

[0041] In sum, a splash guard with a protrusion along the lower edge prevents large air bubbles from entering the principal channel. The protrusion smoothes the flow exiting from the principal channel and pushes it towards the main electrode. By preventing the undesirable entry of air and altering the flow of ink, the protrusion reduces stray ink droplets generated by bubbles bursting as they exit the principal channel. This reduces the risk of print quality defects, cross contamination, sludge build up, and messy leaks that that can cause customers to prematurely replace the ink developer device. The splash guard is a low cost solution that can be implemented as a single part, with no substantial modification of existing components.

[0042] The preceding description has been presented only to illustrate and describe embodiments and examples of the principles described. This description is not intended to be exhaustive or to limit these principles to any precise form disclosed. Many modifications and variations are possible in light of the above teaching.

CLAIMS

WHAT IS CLAIMED IS:

- 5 1. An apparatus for reducing ink droplets (310) generated by
bursting bubbles (300) within an ink developer (100, 400) comprising:
 a surface directing an ink flow (204, 206) into a channel (304); and
 a protrusion (404) within said channel (304), said protrusion (404)
reducing ink droplets (310) generated by said bursting bubbles (300) entrained
10 within said ink flow (204, 206).
2. The apparatus of claim 1, wherein said surface directing said ink
flow (204, 206) into a channel (304) comprises a splash guard (128, 402, 500),
said splash guard (128, 402, 500) being mounted to a base (106, 110).
- 15 3. The apparatus of claim 2, wherein said splash guard (128, 402,
500) comprises a body portion (514), said body portion (514) comprising a first
wall of said channel (304) and said base (106, 110) comprising a second wall of
said channel (304).
- 20 4. The apparatus of claim 3, wherein said splash guard (128, 402,
500) further comprises said protrusion (404, 516), said protrusion (404)
extending along a lower edge of said body portion (514), said protrusion (404,
516) creating a reduced cross-section region within said channel (304).
- 25 5. The apparatus of claim 4, wherein said protrusion (404, 516)
comprises a curved upper surface (508), said curved upper surface (508)
directing said ink flow (204) into said reduced cross-section region.
- 30 6. The apparatus of claim 5, wherein said ink flow (204) passing
through said reduced cross-section region creates a fluid seal which reduces
egress of air through said reduce cross-section region.

7. The apparatus of claim 1, wherein said protrusion (404, 516) further comprises a trailing edge (510), said trailing edge (510) facilitating extraction of said bubbles (300) entrained in said ink flow (204).

5

8. The apparatus of claim 1, wherein an interior pressure of said bubbles (300) is substantially equalized with an ambient pressure at an exit of said channel (304).

10

9. The apparatus of claim 1, wherein said ink flow (204) tends to be adhered to said second wall by surface tension.

10. The apparatus of claim 1, wherein said ink flow (204) exits said channel as a substantially laminar flow (408).

15

11. An apparatus for reducing ink droplets (310) generated by bursting bubbles (300) within an ink developer (100, 400) comprising:
a splash guard (128, 402, 500) configured to direct an ink flow (204, 206) into a channel (304), said splash guard (128, 402, 500) being mounted to a support (110), said channel (304) being formed by a space between said splash guard (128, 402, 500) and said support (110);
a protrusion (404, 516) extending across a substantial portion of a lower edge of said splash guard (402, 500), said protrusion (404, 516) creating a reduced cross-section area within said channel (304)

25

12. The apparatus of claim 11, wherein said protrusion (404, 516) comprises a curved upper surface (508) and a trailing edge (510), said curved upper surface (508) directing said ink flow (204) into said reduced cross-section region, wherein said ink flow (204) passing through said reduced cross-section region creates a fluid seal which reduces egress of air through said reduce cross-section region such that bubbles (300) in said ink flow (204) are reduced, said trailing edge (510) facilitating extraction of said bubbles (300) entrained in

30

said non-developed ink flow (204), said trailing edge (510) further breaking surface tension between said non-developed ink flow (204) and said protrusion (404, 516) such that said non-developed fluid flow (204) tends adhere to said support (110) by surface tension, said non-developed fluid flow (204) exiting
5 said channel in a substantially laminar flow.

13. An ink developer (100, 400) comprising:
an ink source (120) supplying ink (202) to said ink developer (100,
400);
10 an electrode (110);
a developer roller (104), said electrode (110) being configured to develop a portion of said ink (202) onto said developer roller (104);
a splash guard (402, 500), said splash guard (402, 500) being
configured to direct an undeveloped ink flow (204, 206) into a channel (304)
15 located between said electrode (110) and said splash guard (402, 500), said channel (304) having a reduced cross-section area; said reduced cross-section area being configured to reduce bubbles (300) exiting said channel (304) and bursting.

20 14. The ink developer of claim 13, wherein said undeveloped ink flow (204) passes through said reduced cross-section area of said channel (304), thereby creating a fluid seal which prevents air from passing through said fluid seal into said channel (304).

25 15. The ink developer of claim 13, wherein said splash guard (402, 500) further comprises a protrusion (404, 516) having a corner (510), said corner (510) being configured to separate entrained air (300) from said undeveloped ink flow (204).

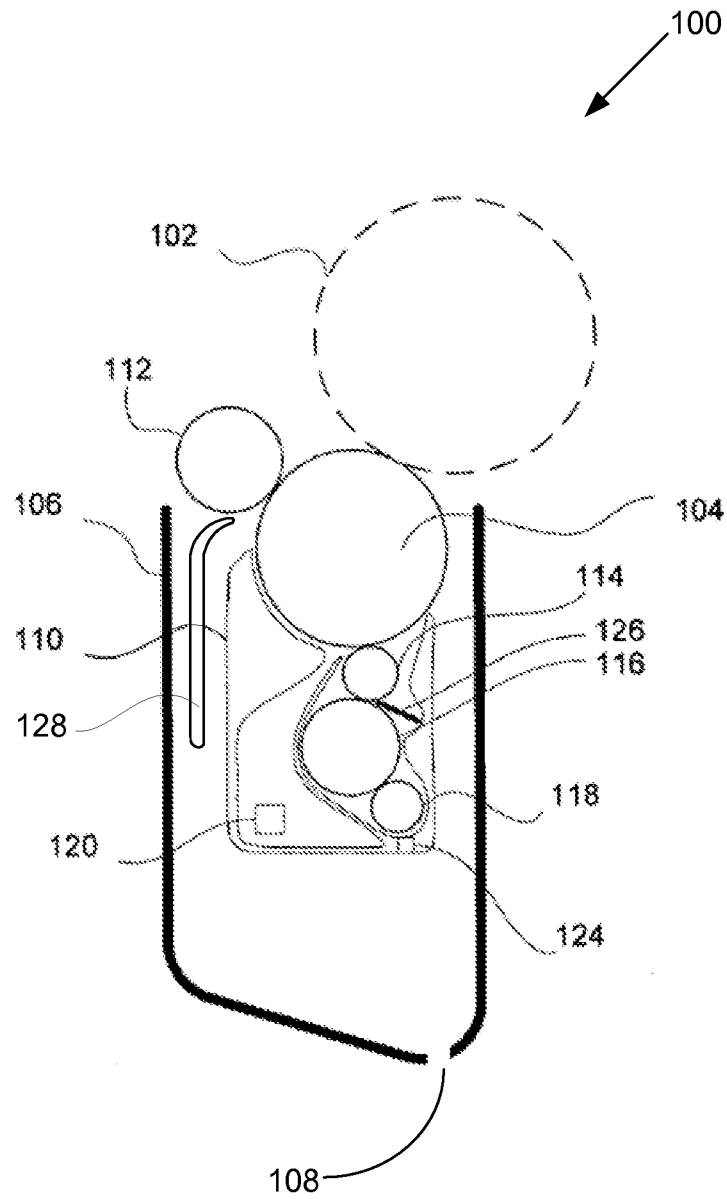

Fig. 1

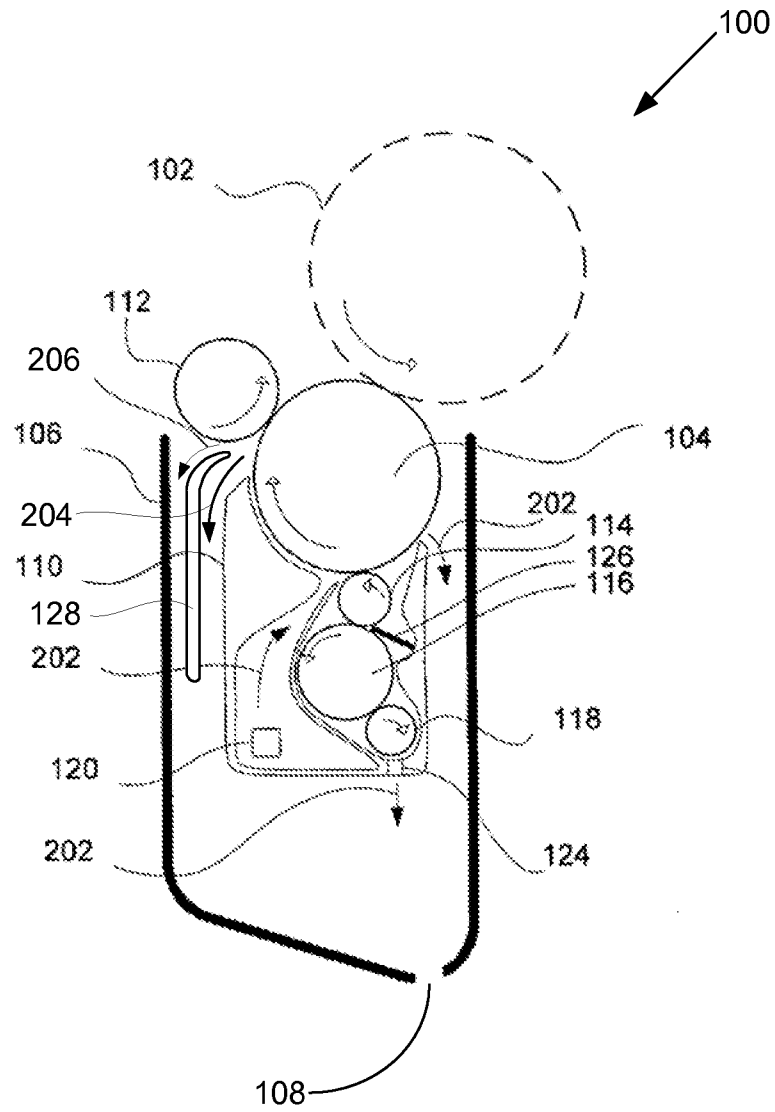

Fig. 2

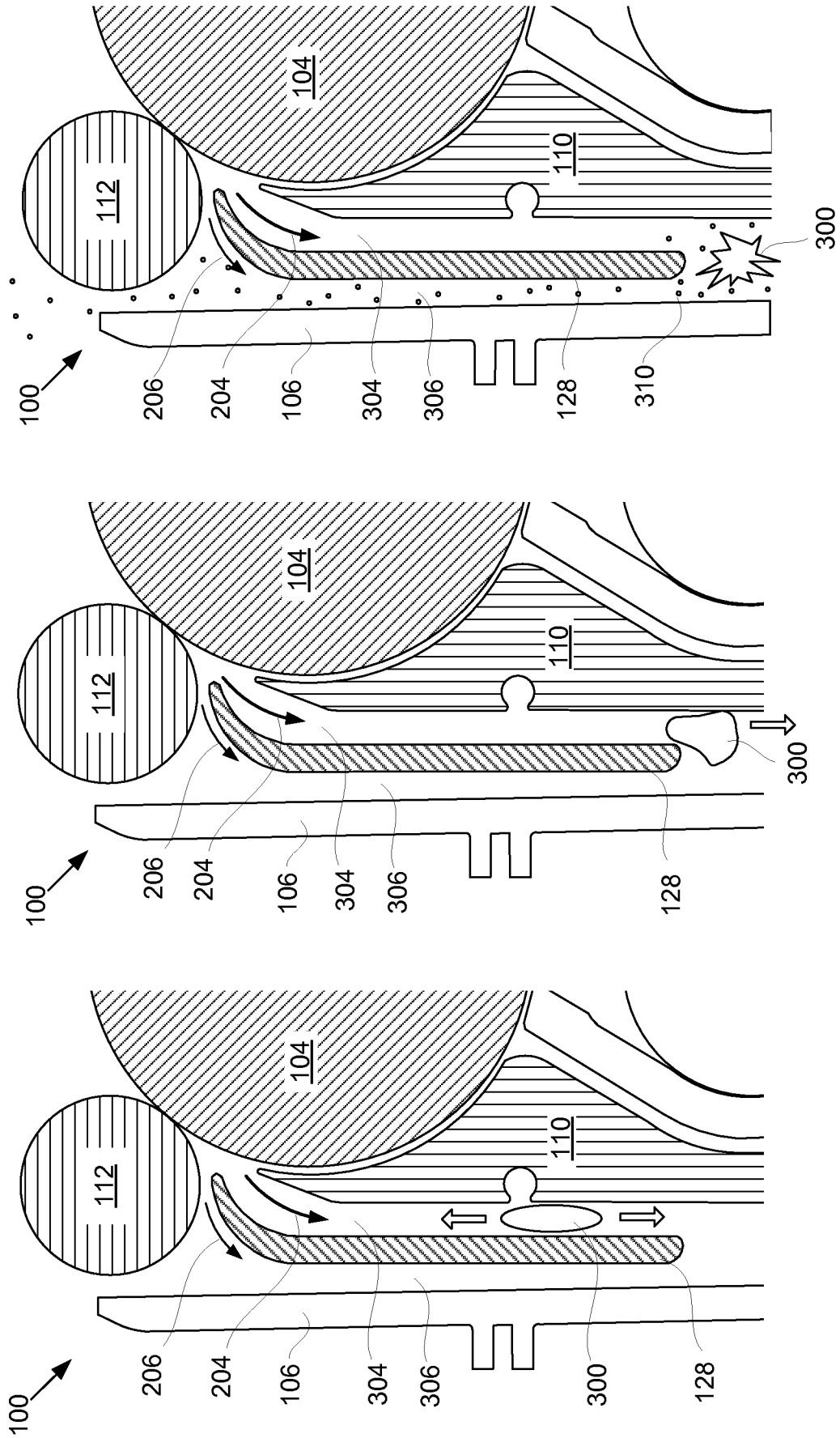

Fig. 3C

Fig. 3B

Fig. 3A

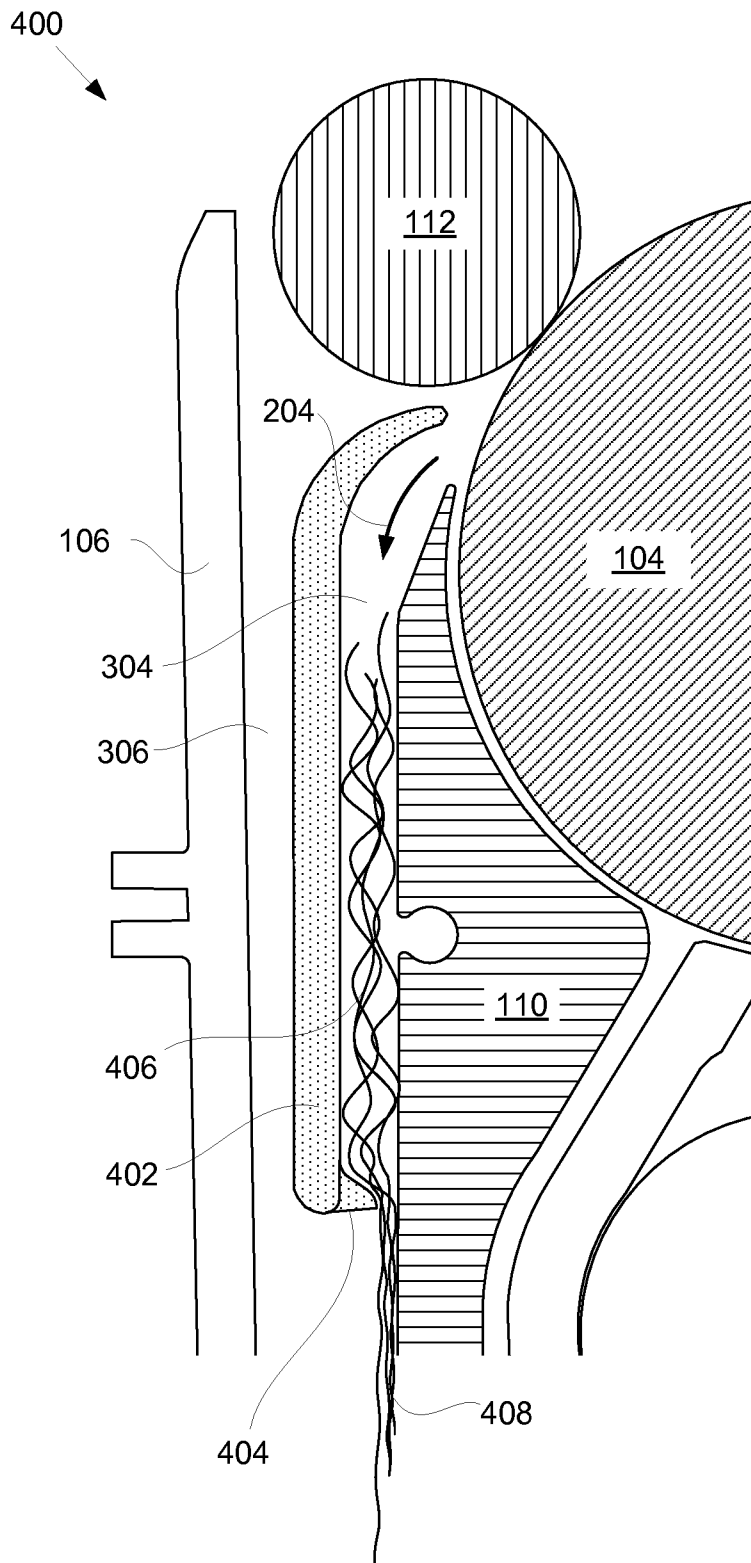

Fig. 4

5/6

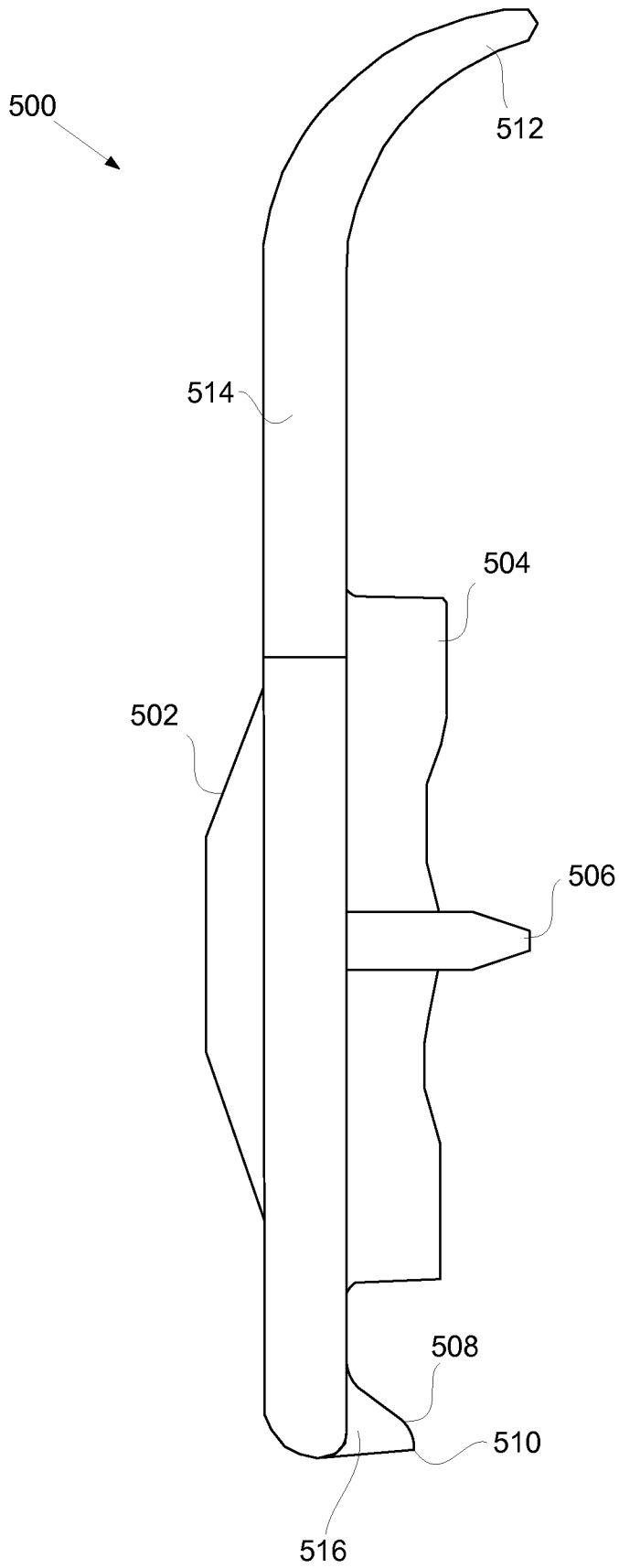

Fig. 5

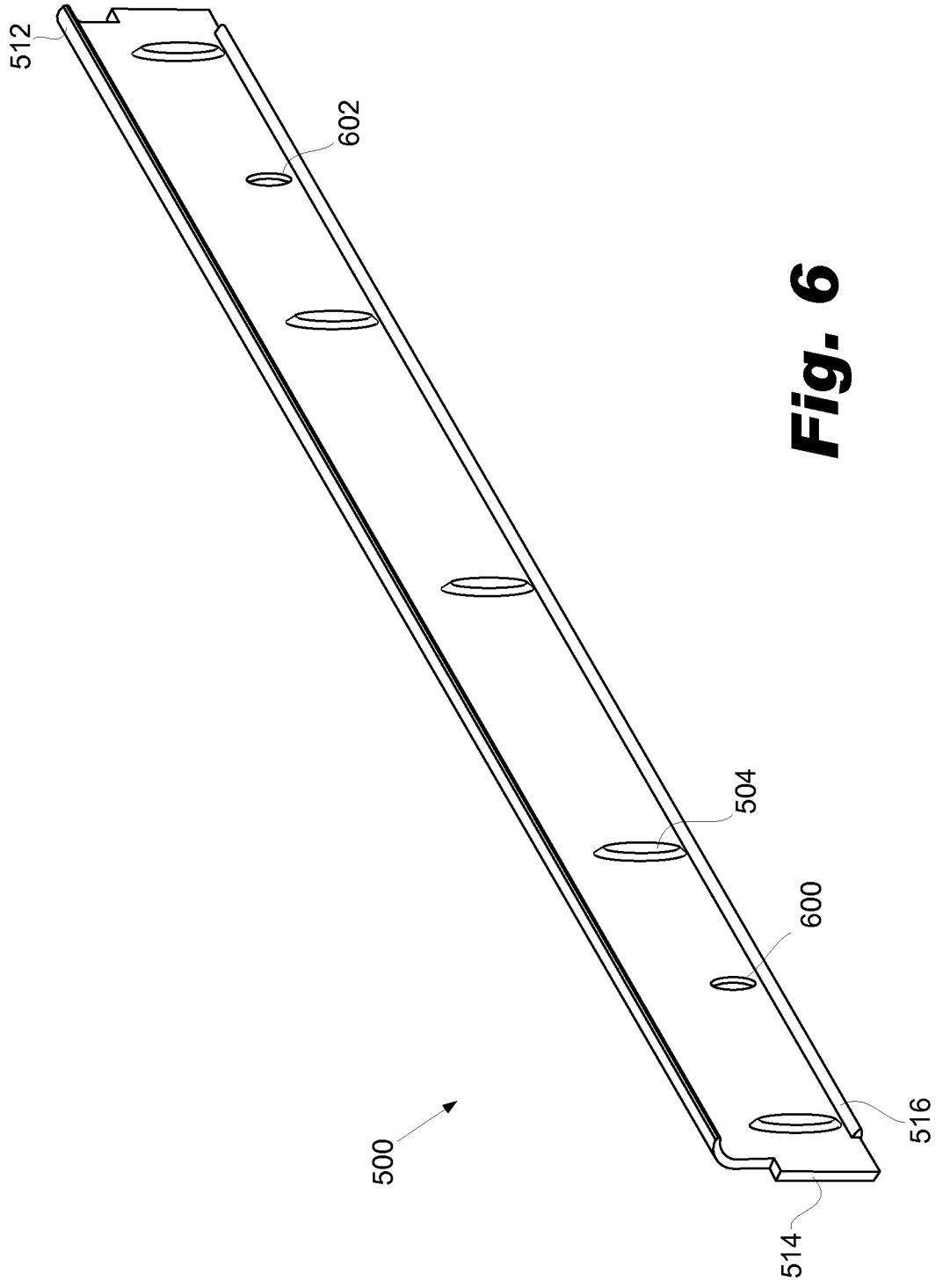

Fig. 6

A. CLASSIFICATION OF SUBJECT MATTER***B41J 2/05(2006.01)i, B41J 2/01(2006.01)i***

According to International Patent Classification (IPC) or to both national classification and IPC

B. FIELDS SEARCHED

Minimum documentation searched (classification system followed by classification symbols)

IPC B41J 2/05, B41J 2/01

Documentation searched other than minimum documentation to the extent that such documents are included in the fields searched

Korean utility models and applications for utility models since 1975

Japanese utility models and applications for utility models since 1975

Electronic data base consulted during the international search (name of data base and, where practicable, search terms used)

eKIPASS(KIPO internal) & keywords: developer, splash guard, protrusion

C. DOCUMENTS CONSIDERED TO BE RELEVANT

Category*	Citation of document, with indication, where appropriate, of the relevant passages	Relevant to claim No.
A	US 7,356,287 B2 (MARCO A. GUZMAN et al.) 08 APRIL 2008 See abstract, column 2, line 65 - column 3, line 67 and Fig. 3.	1-15
A	US 2007/0231013 A1 (GUY HASDAI; SHARON NAGLER) 04 OCTOBER 2007 See abstract, Fig. 2 and paragraphs [0030]-[0034].	1-15
A	JP 2000-221786 A (NEC NIIGATA LTD) 11 AUGUST 2000 See abstract, claims 1, 2, paragraphs [0008]-[0040] and Figs. 1-6	1-15
A	US 4,155,329 A (TAKUZO TSUKAMOTO et al.) 22 MAY 1979 See column 5, line 62 - column 6, line 28 and Fig. 2.	1-15

 Further documents are listed in the continuation of Box C. See patent family annex.

* Special categories of cited documents:

"A" document defining the general state of the art which is not considered to be of particular relevance

"E" earlier application or patent but published on or after the international filing date

"L" document which may throw doubts on priority claim(s) or which is cited to establish the publication date of citation or other special reason (as specified)

"O" document referring to an oral disclosure, use, exhibition or other means

"P" document published prior to the international filing date but later than the priority date claimed

"T" later document published after the international filing date or priority date and not in conflict with the application but cited to understand the principle or theory underlying the invention

"X" document of particular relevance; the claimed invention cannot be considered novel or cannot be considered to involve an inventive step when the document is taken alone

"Y" document of particular relevance; the claimed invention cannot be considered to involve an inventive step when the document is combined with one or more other such documents, such combination being obvious to a person skilled in the art

"&" document member of the same patent family

Date of the actual completion of the international search

19 JANUARY 2009 (19.01.2009)

Date of mailing of the international search report

19 JANUARY 2009 (19.01.2009)

Name and mailing address of the ISA/KR

Korean Intellectual Property Office
Government Complex-Daejeon, 139 Seonsa-ro, Seo-gu, Daejeon 302-701, Republic of Korea

Facsimile No. 82-42-472-7140

Authorized officer

LEE, Yoon Jik

Telephone No. 82-42-481-5731



INTERNATIONAL SEARCH REPORT

Information on patent family members

International application No.

PCT/US2008/065872

Patent document cited in search report	Publication date	Patent family member(s)	Publication date
US 7,356,287 B2	08.04.2008	CA 2585529 A1 EP 1836538 A1 JP 2008-525242 A KR 10-2007-0095283 A US 2006/0153597 A1 WO 2006/076107 A1	20.07.2006 26.09.2007 17.07.2008 28.09.2007 13.07.2006 20.07.2006
US 2007-0231013 A1	04.10.2007	None	
JP 2000-221786 A	11.08.2000	JP 03056194 B1	26.06.2000
US 4,155,329 A	22.05.1979	DE 2803200 A1 DE 2803200 C2 GB 1574198 A JP 53-105750 U	03.08.1978 07.05.1987 03.09.1980 25.08.1978