

(19) World Intellectual Property Organization
International Bureau



(43) International Publication Date
11 December 2008 (11.12.2008)

PCT

(10) International Publication Number
WO 2008/149384 A1

(51) International Patent Classification:
F02M 69/18 (2006.01) F02M 69/54 (2006.01)
F02M 69/20 (2006.01)

(74) Agents: VARADHACHARI, Lakshmikumaran et al.;
Lakshmikumaran & Sridharan Advocates, B6/10, Safdar-
jung Enclave, New Delhi 110 029 (IN).

(21) International Application Number:
PCT/IN2008/000357

(81) Designated States (unless otherwise indicated, for every
kind of national protection available): AE, AG, AL, AM,
AO, AT, AU, AZ, BA, BB, BG, BH, BR, BW, BY, BZ, CA,
CH, CN, CO, CR, CU, CZ, DE, DK, DM, DO, DZ, EC, EE,
EG, ES, FI, GB, GD, GE, GH, GM, GT, HN, HR, HU, ID,
IL, IN, IS, JP, KE, KG, KM, KN, KP, KR, KZ, LA, LC,
LK, LR, LS, LT, LU, LY, MA, MD, ME, MG, MK, MN,
MW, MX, MY, MZ, NA, NG, NI, NO, NZ, OM, PG, PH,
PL, PT, RO, RS, RU, SC, SD, SE, SG, SK, SL, SM, SV,
SY, TJ, TM, TN, TR, TT, TZ, UA, UG, US, UZ, VC, VN,
ZA, ZM, ZW.

(22) International Filing Date: 6 June 2008 (06.06.2008)

(25) Filing Language: English

(26) Publication Language: English

(30) Priority Data:
1196/CHE/2007 8 June 2007 (08.06.2007) IN

(84) Designated States (unless otherwise indicated, for every
kind of regional protection available): ARIPO (BW, GH,
GM, KE, LS, MW, MZ, NA, SD, SL, SZ, TZ, UG, ZM,
ZW), Eurasian (AM, AZ, BY, KG, KZ, MD, RU, TJ, TM),
European (AT, BE, BG, CH, CY, CZ, DE, DK, EE, ES, FI,
FR, GB, GR, HR, HU, IE, IS, IT, LT, LU, LV, MC, MT, NL,
NO, PL, PT, RO, SE, SI, SK, TR), OAPI (BF, BJ, CF, CG,
CI, CM, GA, GN, GQ, GW, ML, MR, NE, SN, TD, TG).

(71) Applicant (for all designated States except US): UCAL
FUEL SYSTEMS LIMITED [IN/IN]; 177 Anna Salai,
Raheja Towers, 7th Floor, Delta, Wing, Chennai 600 002
(IN).

(72) Inventors; and

(75) Inventors/Applicants (for US only): SASIKUMAR,
K [IN/IN]; UCAL Fuel Systems Limited, 177 ANNA
SALAI, Raheja Towers 7th Floor, Delta, Wing, Chennai
600002 (IN). SENTHUR PANDIAN, K [IN/IN]; UCAL
Fuel Systems Limited, 177 ANNA SALAI, Raheja Tow-
ers, 7th Floor, Delta, Wing, Chennai 600002 (IN).

Declaration under Rule 4.17:

— as to the identity of the inventor (Rule 4.17(i))

Published:

— with international search report

[Continued on next page]

(54) Title: VARIABLE PRESSURE FUEL INJECTION SYSTEM

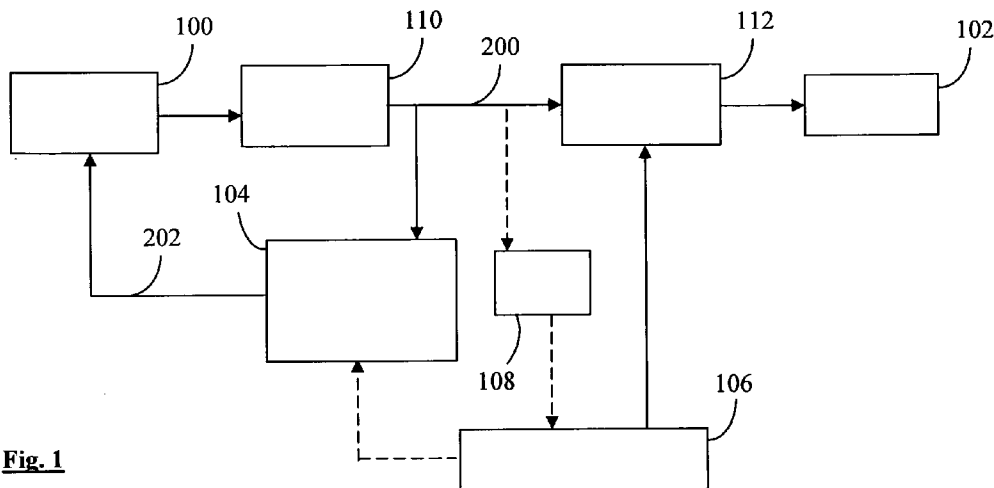

Fig. 1

(57) Abstract: The present subject matter relates to a variable pressure fuel injection system of a vehicle. The variable pressure fuel injection system utilizes an electronically controlled fuel pressure regulator (104) to regulate the fuel pressure across a fuel injector (112) for different operating conditions of the vehicle. The fuel pressure regulator (104) is controlled by an electronic control unit (106) and includes a coil and a plunger arrangement. The electronic control unit, with the help of a pressure sensor (108), ensures optimum atomization of the injected fuel by electronically varying the fuel pressure, thereby achieving efficient output of the engine.

WO 2008/149384 A1



-
- *before the expiration of the time limit for amending the claims and to be republished in the event of receipt of amendments*

VARIABLE PRESSURE FUEL INJECTION SYSTEM

TECHNICAL FIELD:

The present subject matter, in general, relates to a fuel injection system of a vehicle and in particular, relates to a variable pressure fuel injection system with an electronically controlled fuel pressure regulator.

BACKGROUND:

Fuel pressure regulators are provided in a fuel injection system of a vehicle to maintain a desired fuel pressure across a fuel injector. A fuel pressure regulator eliminates sudden and undesirable fluctuations occurring in the fuel pressure in order to ascertain atomization of fuel injected by the fuel injector. Appropriate atomization of fuel is essential in order to maintain fuel economy and substantial reduction in the emission rate.

Typically, a mechanical fuel pressure regulator is located in a fuel inlet line between a fuel pump and the fuel injector for maintaining a constant pressure across the fuel injector at a predetermined pressure. The mechanical fuel pressure regulator has an air reference chamber and a fuel reference chamber separated by a diaphragm. Generally, a spring with a known spring rate is provided in the air reference chamber of the mechanical fuel pressure regulator. The rating of the spring determines the magnitude of fuel pressure to be maintained in the fuel reference chamber and consequently in the fuel inlet line.

The desired pressure of fuel across the fuel injector is preset by the manufacturer of the pressure regulator. However, setting the fuel pressure at a preset value does not ensure optimum atomization of fuel at all operating conditions of the vehicle. This may affect fuel efficiency and fuel economy, thereby leading to reduced power output developed by the engine. Further, inappropriate air-fuel mixture may hamper the efficiency and reliability of the engine, in addition to increased amount of emissions.

SUMMARY:

The subject matter described herein is directed to a variable pressure fuel injection system with an electronically controlled fuel pressure regulator. The present subject matter proposes a solution to maximize the fuel efficiency of the vehicle. In addition to a higher fuel economy, low emission rates are also achieved by the present subject matter. This is achieved by effective atomization of the fuel injected into an internal combustion engine. In accordance with at least one embodiment of the present subject matter, a variable pressure fuel injection system comprising a fuel inlet line, a fuel outlet line and a fuel injector is provided. The fuel injector is hydraulically connected to the fuel inlet line and injects the pressurized fuel into the engine. The variable pressure fuel injection system further comprises a control system having an electronically controlled fuel pressure regulator hydraulically connecting the fuel inlet line and the fuel outlet line. The fuel pressure regulator includes a housing having an inlet chamber, an outlet chamber and a passage connecting the inlet chamber and the outlet chamber. The inlet chamber is connected to the fuel inlet line whereas the outlet chamber is connected to the fuel outlet line. The fuel pressure regulator also includes an actuator assembly having a movable armature and a coil that encloses the movable armature. The movable armature controls

the flow of fuel from the inlet chamber to the outlet chamber. The variable pressure fuel injection system further comprises an electronic control unit that energizes the coil based on different operating conditions, thereby reciprocating the movable armature to regulate fuel pressure entering into the fuel injector at different operating conditions. A pressure sensor is also disposed in the fuel inlet line. The pressure sensor measures the pressure in the fuel inlet line and communicates with the electronic control unit for control of the fuel pressure regulator.

In another embodiment of the present subject matter, the variable pressure fuel injection system comprises the fuel inlet line, the fuel outlet line and the fuel injector. The fuel injector is hydraulically connected to the fuel inlet line. The fuel injector injects pressurized fuel to the engine. The variable pressure fuel injection system includes a control system having a fuel pressure regulator hydraulically connecting the fuel inlet line and the fuel outlet line. The fuel pressure regulator includes a housing having an actuator chamber and a fuel chamber. The actuator chamber and the fuel chamber are separated by a diaphragm. An actuator assembly is disposed in the actuator chamber. The actuator assembly includes a movable armature and a coil enclosing the movable armature. A pressure plate assembly is disposed in the fuel chamber. The pressure plate assembly is attached to the movable armature for regulating flow of fuel from the fuel inlet line to the fuel outlet line. An electronic control unit is provided in the variable pressure fuel injection system that energizes the coil based on different operating conditions, thereby reciprocating the movable armature to regulate the fuel pressure entering into the fuel injector. A pressure sensor is disposed in the fuel inlet line for measuring the pressure in

the fuel inlet line. The pressure sensor communicates with the electronic control unit for precise control of the fuel pressure regulator.

These and other features, aspects, and advantages of the present subject matter will become better understood with reference to the following description and appended claims. This summary is provided to introduce a selection of concepts in a simplified form. This summary is not intended to identify key features or essential features of the claimed subject matter, nor is it intended to be used to limit the scope of the claimed subject matter.

BRIEF DESCRIPTION OF THE DRAWINGS:

The above and other features, aspects and advantages of the subject matter will be better understood with regard to the following description, appended claims, and accompanying drawings where:

FIG. 1 shows a block diagram of a variable pressure fuel injection system of a vehicle.

FIG. 2 shows a sectional view of a fuel pressure regulator of a variable pressure fuel injection system of a vehicle according to a first embodiment of the present subject matter.

FIG. 3 shows a perspective view of the fuel pressure regulator of a variable pressure fuel injection system of a vehicle shown in **Fig. 2**.

FIG. 4 shows a sectional view of the fuel pressure regulator of a variable pressure fuel injection system of a vehicle according to a second embodiment of the present subject matter.

FIG.5 shows a sectional view of the fuel pressure regulator of a variable pressure fuel injection system of a vehicle according to a third embodiment of the present subject matter.

DETAILED DESCRIPTION:

The subject matter described herein is directed to a variable pressure fuel injection system of a vehicle and in particular relates to a variable pressure fuel injection system with an electronically controlled fuel pressure regulator. The present subject matter proposes a solution to maximize the fuel efficiency of the vehicle by electronically varying the pressure of the fuel injected inside an engine cylinder at different operating conditions of the vehicle. In addition to higher fuel economy, lower emission rates are also achieved by the present subject matter as proper atomization of the injected fuel is ensured.

FIG.1 shows a block diagram of a variable pressure fuel injection system of a vehicle. In the variable pressure fuel injection system, pressure of fuel from a fuel tank **100** is varied depending upon different operating conditions of the vehicle. The variable pressure fuel injection system utilizes a control system for regulating the pressure of fuel to be injected into an internal combustion engine **102**. The control system includes an electronic fuel pressure regulator **104**, an electronic control unit (ECU) **106** and a pressure sensor **108**.

Regulation of fuel pressure is mainly controlled by employing the fuel pressure regulator **104**, which is electronically controlled by the ECU **106**. The ECU **106** is aided by the pressure sensor **108** that monitors the pressure of the fuel from a fuel pump **110** entering into a fuel injector **112**.

The fuel pump **110** pumps the fuel from the fuel tank **100** into the fuel injector **112** and the fuel pressure regulator **104**. The fuel, pumped by the fuel pump **110**, is at a certain pressure called as forward fuel pressure. Subsequently, when fuel approaches the fuel injector **112**, it experiences a backward fuel pressure due to the closed state of the injector **112**. The fuel with a pressure equal to the difference in the forward and backward fuel pressures enters the fuel pressure regulator **104**.

The pressure sensor **108** is provided in line between the fuel pump **110** and the fuel injector **112** to constantly monitor the pressure of fuel entering the fuel injector **112**. Whenever the pressure of fuel entering the fuel injector **112** exceeds a certain predetermined threshold value, the pressure sensor **108** alerts the ECU **106**. On receiving the alert signals from the pressure sensor **108**, the ECU **106** communicates with the fuel pressure regulator **104**. Depending upon the magnitude of rise in fuel pressure beyond the threshold value, the fuel pressure regulator **104** allows the excess fuel to drain into the fuel tank **100**. This leads to the reduction of the back fuel pressure, thereby reducing the pressure of fuel entering the fuel injector **112**. The fuel pressure regulator **104** along with the fuel tank **100** and the fuel pump **110** forms a closed loop to achieve the desired fuel pressure which constantly varies according to the operating conditions, such as engine speed and engine load, of the vehicle.

FIG.2 shows a sectional view of the fuel pressure regulator **104** of the variable pressure fuel injection system of the vehicle according to a first embodiment of the present subject matter. The fuel pressure regulator **104** is hydraulically connected to a fuel inlet line **200** and a fuel outlet line **202**. The fuel pressure regulator **104** of the present embodiment is configured as a solenoid valve. The fuel pressure regulator **104** includes a housing **204** having an inlet chamber **206**, an outlet chamber **208** and a passage connecting the inlet chamber **206** and the outlet chamber **208**. The inlet chamber **206** is connected to the fuel inlet line **200** whereas the outlet chamber **208** is connected to the fuel outlet line **202**. In the present embodiment, the housing **204** is a two piece assembly having a cap **210** and a mounting block **212**. However, in another embodiment, the housing **204** can be a single piece in structure. The fuel pressure regulator **104** further comprises an actuator assembly having a coil **214** and a movable armature **216** enclosed within the coil **214**. The movable armature **216** is provided within the passage connecting the inlet chamber **206** and the outlet chamber **208** and controls the flow of fuel from the inlet chamber **206** to the outlet chamber **208**.

The fuel pressure regulation is achieved by energizing the coil **214** placed within the cap **210**. When the pressure in the line between the fuel pump **110** and the fuel injector **112** raises above the threshold value, the pressure sensor **108** measures this pressure and immediately sends corresponding signals to the ECU **106**. The ECU **106**, on receiving signals from the pressure sensor **108** energizes the coil **214**, thereby resulting in reciprocating movement of the movable armature **216**. The reciprocating movement of the movable armature **216** leads to opening of the passage between the inlet chamber **206**

and the outlet chamber **208**, thereby leading to draining of fuel with excess pressure back into the fuel tank **100**.

FIG.3 shows a perspective view of the fuel pressure regulator **104** of the variable pressure fuel injection system of the vehicle according to the first embodiment of the present subject matter. As shown in **Fig. 3**, the fuel inlet line **200** is disposed at the cap **210** whereas the fuel outlet line **202** is disposed at the mounting block **212**.

FIG.4 shows a sectional view of the fuel pressure regulator **104** of the variable pressure fuel injection system of the vehicle according to a second embodiment of the present subject matter. In the present embodiment, the fuel pressure regulator **104** is configured as a stepper motor **400**. The stepper motor **400** is electronically controlled by the ECU **106**. The fuel pressure regulator **104** includes a housing having a fuel chamber **402** and an actuator chamber **404** separated by a diaphragm **406**. The fuel inlet line **200** and the fuel outlet line are provided in the fuel chamber **402** of the fuel pressure regulator **104**. The movable armature **216** is disposed in the actuator chamber **404** and is coupled to a pressure plate assembly **408**. The pressure plate assembly **408** is disposed in the fuel chamber **402** and controls the flow of fuel from the fuel inlet line **200** to the fuel outlet line **202**

Fuel enters the fuel chamber **402** through the fuel inlet line **200** and is obstructed by the pressure plate assembly **408**. In case the pressure of the fuel in the fuel inlet line exceeds a certain predetermined value, the pressure sensor **108** senses this pressure rise and sends certain signals to the ECU **106**. The ECU **106** then regulates the pressure of the fuel at an optimum level by energizing the coil **214** thereby causing the reciprocating movement of the movable armature **216**. This causes the pressure plate assembly **408** to

move up with the movable armature **216**, leading to the opening of the fuel outlet line **202**, thereby bleeding the excess fuel to the fuel tank **100**.

FIG.5 shows a sectional view of the fuel pressure regulator **104** of the variable pressure fuel injection system of the vehicle according to a third embodiment of the present subject matter. In the present embodiment, the movable armature **216** is integrated with a metering needle **500**. The metering needle **500** has a tapered end **502**. The tapered end **502** of the metering needle **500** characterizes the closing for the fuel outlet line **202**. The rise in pressure of the fuel above the threshold value causes the stepper motor **400** to lift the metering needle **500**. The position of the tapered end **502** of the metering needle **500** determines the size of the aperture created for bleeding the fuel out to the fuel tank **100**.

The previously described versions of the subject matter and its equivalent thereof have many advantages, including those, which are described below. The present subject matter proposes a solution to maximize the fuel efficiency of the vehicle. In addition to high fuel economy, low emission rate is also achieved by effectively and efficiently varying the pressure of the fuel according to different operating conditions of the vehicle. Variation of fuel pressure according to the operating conditions of the vehicle leads to proper atomization of the fuel. This results in proper burning of the fuel which consequently leads to increase in fuel economy and reduction in the emission rates.

Although the subject matter has been described in considerable detail with reference to certain preferred embodiments thereof, other embodiments are also possible. As such, the spirit and scope of the appended claims should not be limited to the description of the preferred embodiment contained therein.

I/We claim:

1. A variable pressure fuel injection system comprising:

a fuel inlet line **200**;

a fuel outlet line **202**;

a fuel injector **112** hydraulically connected to said fuel inlet line **200**; and

a control system;

characterized in that said control system comprising

an electronic fuel pressure regulator **104** hydraulically connecting said fuel inlet line **200** and said fuel outlet line **202**, said electronic fuel pressure regulator **104** comprising:

a housing **204** having an inlet chamber **206**, an outlet chamber **208** and a passage connecting said inlet chamber **206** and said outlet chamber **208**, said inlet chamber **206** connected to said fuel inlet line **200** and said outlet chamber **208** connected to said fuel outlet line **202**; and

an actuator assembly having a movable armature **216** and a coil **214** enclosing said movable armature **216**, wherein said movable armature **216** controls the flow of fuel from said inlet chamber **206** to said outlet chamber **208**; and

an electronic control unit **106** energizing said coil based on different operating conditions, thereby reciprocating said movable armature **216** to regulate fuel pressure entering into said fuel injector **112** at different operating conditions.

2. A variable pressure fuel injection system comprising:

a fuel inlet line **200**;

a fuel outlet line **202**;

a fuel injector **112** hydraulically connected to said fuel inlet line **200**; and

a control system

characterized in that said control system comprising

an electronic fuel pressure regulator **104** hydraulically connecting said fuel inlet line **200** and said fuel outlet line **202**, said electronic fuel pressure regulator **106** comprising:

a housing having an actuator chamber **404** and a fuel chamber **406**, wherein said fuel chamber **406** connects said fuel inlet line **200** and said fuel outlet line **202**;

an actuator assembly disposed in said actuator chamber **404**, said actuator assembly having a movable armature **216** and a coil **214** enclosing said movable armature **216**; and

a pressure plate assembly **408** disposed in said fuel chamber **406**, said pressure plate assembly **408** attached to said movable armature **216** for regulating flow of fuel from said fuel inlet line **200** to said fuel outlet line **202**; and

an electronic control unit **106** energizing said coil **214** based on different operating conditions, thereby reciprocating said movable armature **216** in said passage to regulate fuel pressure entering into said fuel injector **112** at different operating conditions.

3. The variable pressure fuel injection system as claimed in 2, wherein said actuator chamber and said fuel chamber separated by a diaphragm.
4. The variable pressure fuel injection system as claimed in claim 2, wherein said pressure plate assembly **408** includes a metering needle.
5. The variable pressure fuel injection system as claimed in claim 1 or 2 further comprises a pressure sensor **108** disposed in said fuel inlet line **200** for measuring pressure in said fuel inlet line **200**, said pressure sensor **108** communicating with said electronic control unit **106** for precise control of said electronic fuel pressure regulator **104**.
6. The variable pressure fuel injection system as claimed in claim 1 or 2, wherein said fuel inlet line **200** comprises a fuel tank **100** and a fuel pump **110**.
7. The variable fuel pressure injection system as claimed in 6, wherein said fuel outlet line **202** hydraulically connects said electronic fuel pressure regulator **106** to said fuel tank **100**.
8. The variable pressure fuel injection system as claimed in 1 or 2, wherein said fuel in said fuel inlet line **200** is pressurized by a back pressure created by said electronic fuel pressure regulator **106**.
9. The variable pressure fuel injection system as claimed in 1 or 2, wherein said housing can be a single piece or a two piece assembly.
10. The variable pressure fuel injection system as claimed in 1 or 2, wherein the position of said movable armature **216** defines the amount of fuel flowing from said fuel inlet line **200** to said fuel outlet line **202**.

11. The variable pressure fuel injection system as claimed in 1 or 2, wherein said actuator assembly is a solenoid operated valve or a stepper motor.
12. The variable pressure fuel injection system as claimed in 1 or 2, wherein said electronic control unit **106** controls said electronic fuel pressure regulator **106** based on engine speed and engine load.

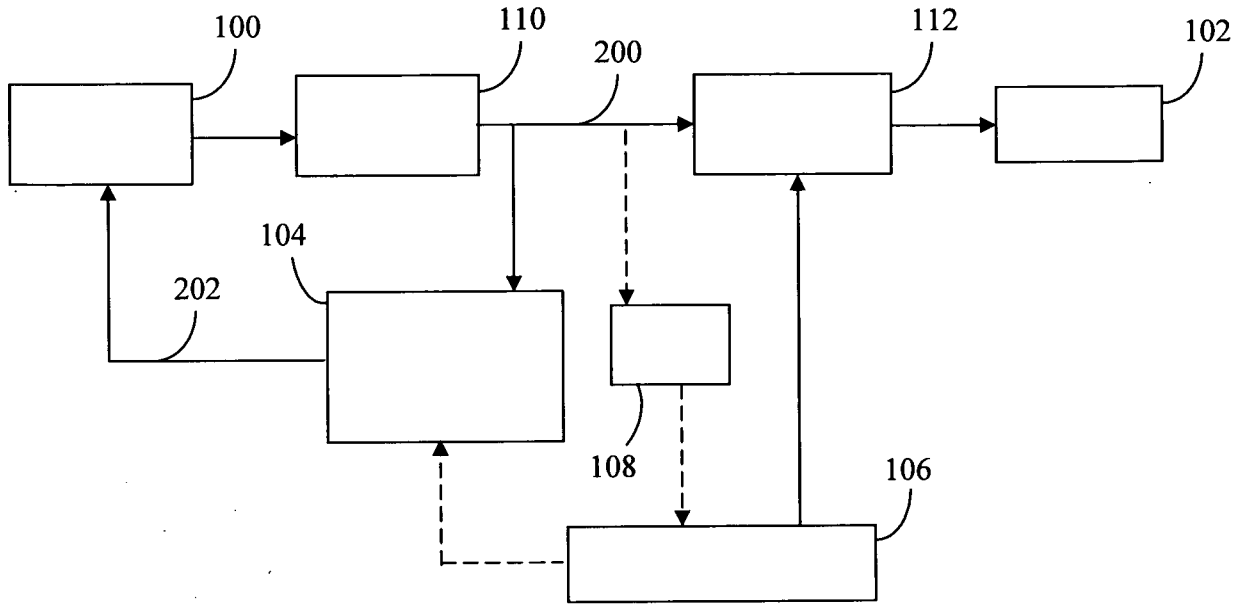

Fig. 1

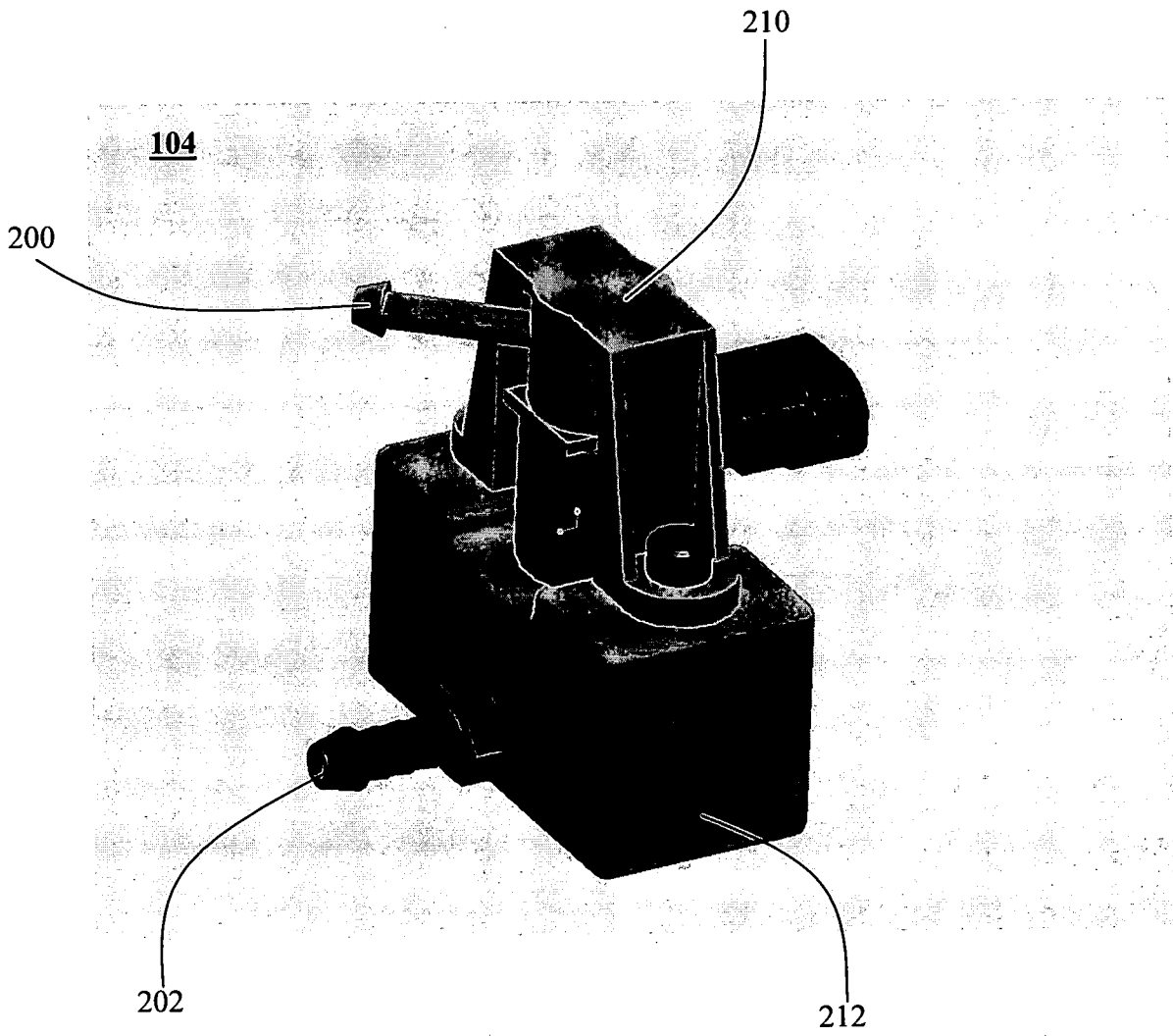

Fig. 3

104

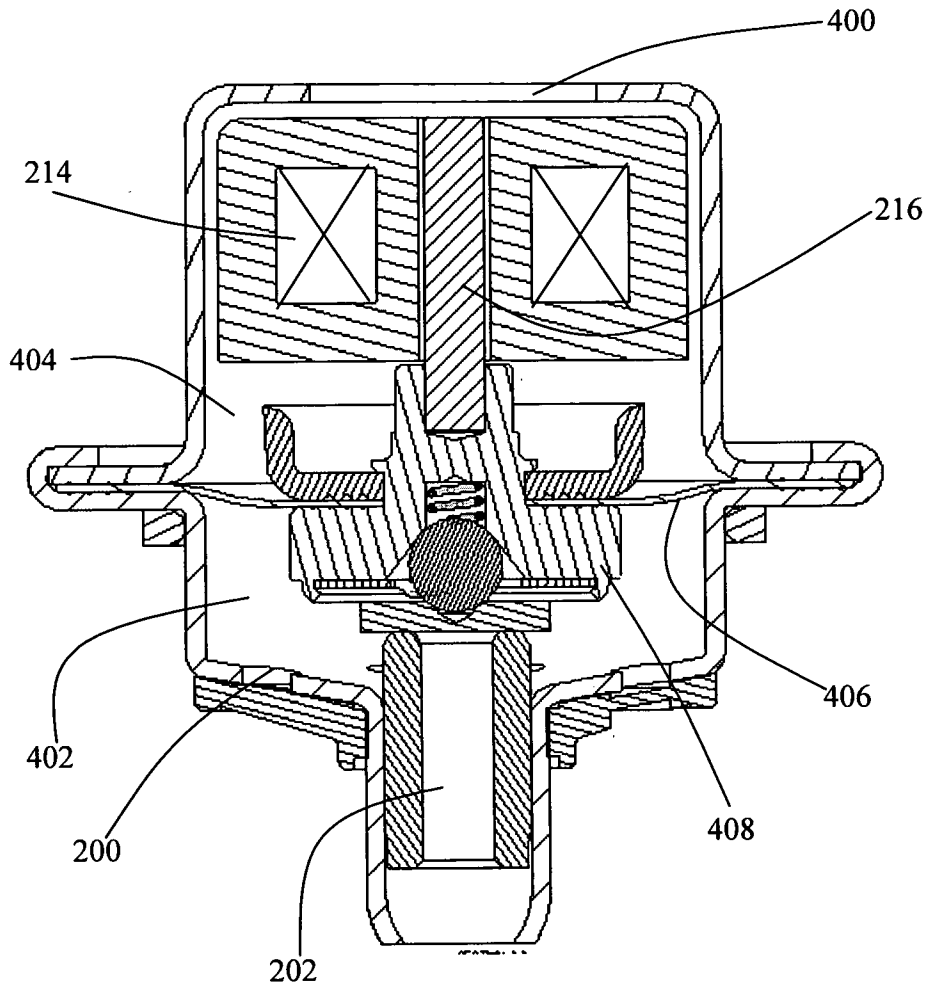

Fig. 4

104

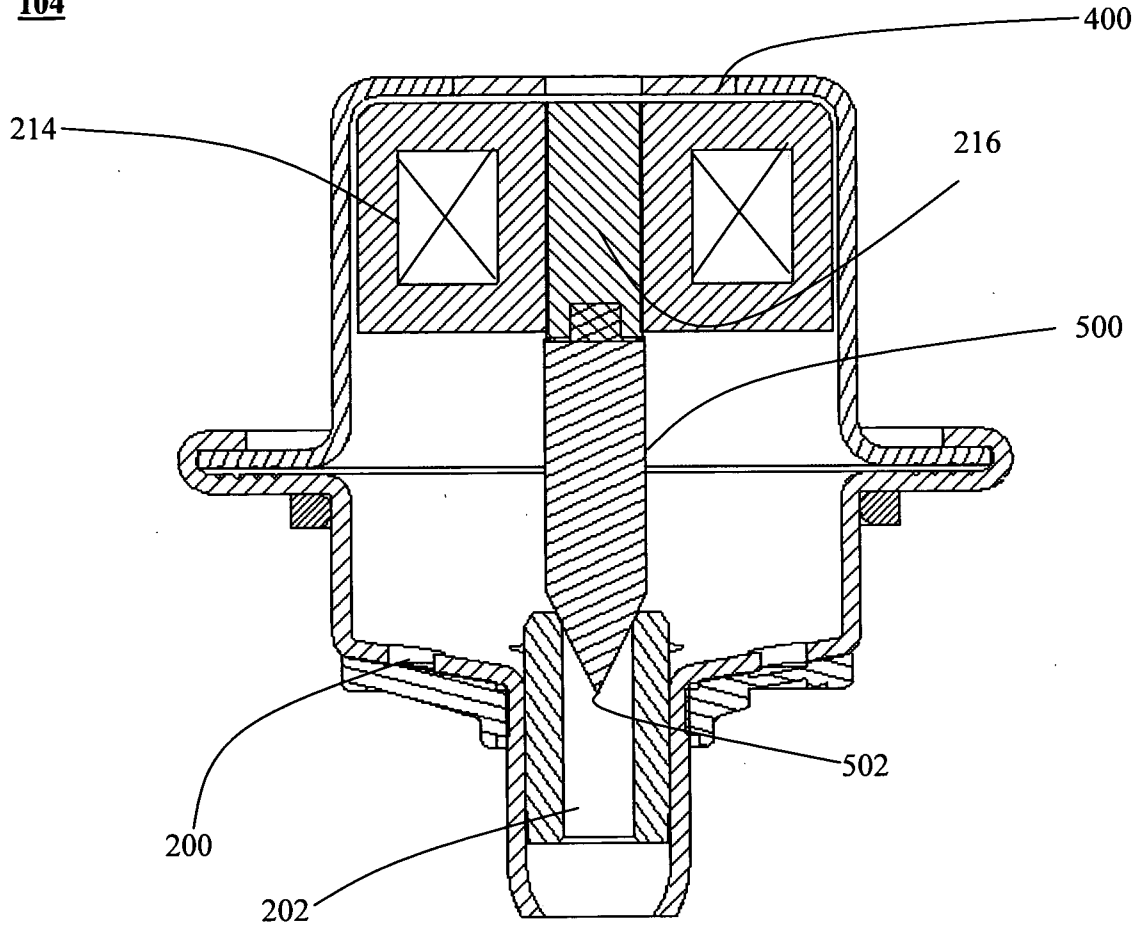

Fig. 5

INTERNATIONAL SEARCH REPORT

International application No

PCT/IN2008/000357

A. CLASSIFICATION OF SUBJECT MATTER

INV. F02M69/18 F02M69/20 F02M69/54

According to International Patent Classification (IPC) or to both national classification and IPC

B. FIELDS SEARCHED

Minimum documentation searched (classification system followed by classification symbols)
F02M

Documentation searched other than minimum documentation to the extent that such documents are included in the fields searched

Electronic data base consulted during the international search (name of data base and, where practical, search terms used)

EPO-Internal

C. DOCUMENTS CONSIDERED TO BE RELEVANT

Category*	Citation of document, with indication, where appropriate, of the relevant passages	Relevant to claim No.
X	JP 59 043932 A (MITSUBISHI ELECTRIC CORP) 12 March 1984 (1984-03-12) abstract	1-12
X	GB 2 073 318 A (NISSAN MOTOR) 14 October 1981 (1981-10-14) figures 1,2	1-4, 6-12
X	DE 100 16 242 A1 (SIEMENS AG [DE]) 4 October 2001 (2001-10-04) paragraph [0018] paragraph [0027] - paragraph [0029]; figures 1,2	1,5-12
X	EP 1 291 520 A (PIERBURG GMBH [DE]) 12 March 2003 (2003-03-12) paragraph [0011]; figure 3	1,5-9, 11,12
	-/--	

 Further documents are listed in the continuation of Box C. See patent family annex.

* Special categories of cited documents :

- *A* document defining the general state of the art which is not considered to be of particular relevance
- *E* earlier document but published on or after the international filing date
- *L* document which may throw doubts on priority claim(s) or which is cited to establish the publication date of another citation or other special reason (as specified)
- *O* document referring to an oral disclosure, use, exhibition or other means
- *P* document published prior to the international filing date but later than the priority date claimed

- *T* later document published after the international filing date or priority date and not in conflict with the application but cited to understand the principle or theory underlying the invention
- *X* document of particular relevance; the claimed invention cannot be considered novel or cannot be considered to involve an inventive step when the document is taken alone
- *Y* document of particular relevance; the claimed invention cannot be considered to involve an inventive step when the document is combined with one or more other such documents, such combination being obvious to a person skilled in the art.
- *&* document member of the same patent family

Date of the actual completion of the international search

29 October 2008

Date of mailing of the international search report

14/11/2008

Name and mailing address of the ISA/

European Patent Office, P.B. 5818 Patentlaan 2
NL - 2280 HV Rijswijk
Tel. (+31-70) 340-2040,
Fax: (+31-70) 340-3016

Authorized officer

Schmitter, Thierry

INTERNATIONAL SEARCH REPORT

International application No

PCT/IN2008/000357

C(Continuation). DOCUMENTS CONSIDERED TO BE RELEVANT

Category*	Citation of document, with indication, where appropriate, of the relevant passages	Relevant to claim No.
X	EP 0 072 034 A (MITSUBISHI ELECTRIC CORP [JP]) 16 February 1983 (1983-02-16) figure 1	1,6-12
X	US 4 310 142 A (LUDWIG GEORGE C) 12 January 1982 (1982-01-12) column 3, line 59 - column 4, line 6; figures 5,6	2-4,6-12
X	DE 10 2004 020941 B3 (PIERBURG GMBH [DE]) 5 January 2006 (2006-01-05) paragraph [0031]; figure 2	1,6-12
P,X	EP 1 826 394 A (DENSO CORP [JP]) 29 August 2007 (2007-08-29) paragraph [0012] - paragraph [0013]; figures 1,4	1,5-12
A	EP 1 234 976 A (PIERBURG GMBH [DE]) 28 August 2002 (2002-08-28) paragraph [0014]; figures 1,2	1-12

INTERNATIONAL SEARCH REPORT

Information on patent family members

International application No

PCT/IN2008/000357

Patent document cited in search report		Publication date	Patent family member(s)	Publication date
JP 59043932	A	12-03-1984	JP 1060661 B JP 1574811 C	25-12-1989 20-08-1990
GB 2073318	A	14-10-1981	DE 3110381 A1 JP 56132454 A US 4419976 A	25-02-1982 16-10-1981 13-12-1983
DE 10016242	A1	04-10-2001	NONE	
EP 1291520	A	12-03-2003	DE 10143891 A1 US 2003047169 A1	27-03-2003 13-03-2003
EP 0072034	A	16-02-1983	AU 557670 B2 AU 8706482 A DE 3274485 D1 JP 58027874 A US 4481926 A	08-01-1987 12-05-1983 15-01-1987 18-02-1983 13-11-1984
US 4310142	A	12-01-1982	CA 1157738 A1	29-11-1983
DE 102004020941	B3	05-01-2006	NONE	
EP 1826394	A	29-08-2007	CN 101029695 A JP 2007225081 A US 2007200655 A1	05-09-2007 06-09-2007 30-08-2007
EP 1234976	A	28-08-2002	DE 10107618 A1 ES 2266081 T3 US 2002113220 A1	29-08-2002 01-03-2007 22-08-2002