



(86) Date de dépôt PCT/PCT Filing Date: 2014/01/28  
 (87) Date publication PCT/PCT Publication Date: 2014/08/14  
 (45) Date de délivrance/Issue Date: 2023/10/10  
 (85) Entrée phase nationale/National Entry: 2015/09/04  
 (86) N° demande PCT/PCT Application No.: US 2014/013326  
 (87) N° publication PCT/PCT Publication No.: 2014/123722  
 (30) Priorité/Priority: 2013/01/24 (US61/849,339)

(51) Cl.Int./Int.Cl. *A01G 9/02* (2018.01),  
*A01G 31/02* (2006.01)  
 (72) Inventeur/Inventor:  
PRESCOTT, MARK RANDELL, US  
 (73) Propriétaire/Owner:  
AIR8GREEN, LLC, US  
 (74) Agent: RIDOUT & MAYBEE LLP

(54) Titre : SYSTEME D'AIR DE CROISSANCE PRESSURISE POUR SYSTEMES DE PLANTATION VERTICALE ET HORIZONTALE

(54) Title: PRESSURIZED GROWING AIR SYSTEM FOR VERTICAL AND HORIZONTAL PLANTING SYSTEMS

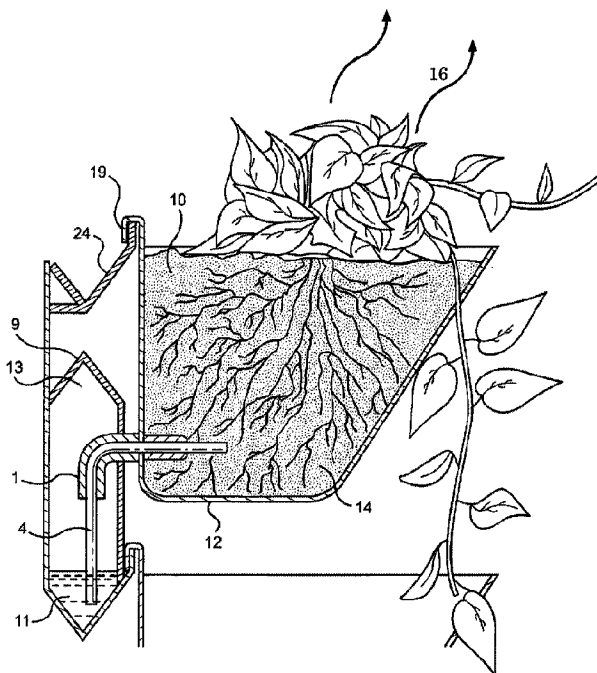

(57) Abrégé/Abstract:

A Growing apparatus for cleansing air and watering plant, wherein the apparatus includes a modular panel constructed for either vertical or horizontal planting systems, including connecting couplers and end caps for directing water flow from upper to lower channels. Panel consist of 5 channels per section with opposing conical top and bottom set at 45 degree angles (fig.9-23) for both channeling water and accepting irrigation nozzle. System can also use a horizontal channel system while the orientation is different but function is the same. Panels stack nesting consecutively on top of each other to make larger systems.

## ABSTRACT

A Growing apparatus for cleansing air and watering plant, wherein the apparatus includes a modular panel constructed for either vertical or horizontal planting systems, including connecting couplers and end caps for directing water flow from upper to lower channels. Panel consist of 5 channels per section with opposing conical top and bottom set at 45 degree angles (fig.9-23) for both channeling water and accepting irrigation nozzle. System can also use a horizontal channel system while the orientation is different but function is the same. Panels stack nesting consecutively on top of each other to make larger systems.

# **PRESSURIZED GROWING AIR SYSTEM FOR VERTICAL AND HORIZONTAL PLANTING SYSTEMS**

## **FIELD OF THE INVENTION**

[0001] This invention relates to the field of water and air delivery systems for plants.

## **SUMMARY**

[0002] The System Pressurized vertical-horizontal growing system solves a number of problems that convention irrigation systems have as well as growing systems for the purpose of Phytoremediation. Including the elimination of water catch basins, electronically monitoring equipment, or the need for specially modified planting mediums. This system while using a capillary wick does not require capillary "action" from the wick for moisture movement, but relies on air movement to create a "negative" air pressure for drawing water into the soil sub-straight. This process created by the air channel location within the wick is self regulating. Whereas the more air flow moving through the system the more water movement thus creating a balance with the water to air ratio insuring healthy roots and plants without relying on electronic equipment. It is also a benefit of the process to create a microclimate and moisture rich area around the plant grown, this is accomplished by the movement of air "pushing" through the soil. In addition our air flow rates are more favorable to total filtration per pass of air due to slower rates. In addition air filtration can be targeted to specific areas where air remediation is needed.

## BACKGROUND

[0003] Indoor green walls using plants have been increasingly popular for aesthetics, improved air quality, humidity and natural cooling. Planting system both horizontal and vertical systems have been developed for air cleaning using the microbes living around plant roots for air cleaning. These green structures can pose a number of problems for the owner, mold, algae, and health issues from dirty catch basin reservoir. Drip irrigation or "ebb and flow" systems are the most common methods of irrigation for vertical systems. Because each plant tray drains into the next consecutive tray all the dirt/debris flows into catch basin that is open and exposed to the indoor environment. Poor air circulation creates mold and algae problems, and poor growing conditions for the plants. The plants ability to clean the air is inhibited by these issues and dramatically reduces the potential healthy effects green walls can have. Aeroponic systems like US850523B2 Luebbers, Hensley, use spray methods for watering plants still resulting in a mixture of soil and debris in irrigation water which will frequently need to be cleaned. Drip vertical systems like patent #EP1416229A2 Darlington, use an air permeable sub- straight creating a similar problem of organic/dirt debris building up in containment reservoir. EP2654400A 1 Paleszezak discloses a series of pipes, with alternating prismatic shaped bins, for air circulation. W02011 019277 A2 Kluiiver discloses a system where indoor pollution is captured on the leaves of a plant and washed into substrate. System W0201 0033423A 1 Wolverton /Middlemark, use beds with various sized substrate to and drip irrigation to process indoor air through. Patent #647780582 Ware uses similar drip methods, again mixing irrigation water directly with planting mediums and debris. Therefore it is the purpose of this invention to

demonstrate an irrigation system that efficiently delivers water and air directly into planting substrate that does not need modification for air flow, while keeping irrigation water separate from living area. It is the purpose of this invention to use air movement to facilitate water movement over a modified wicking system into the soil, not using the capillary nature of the wick to do so as US patent #4 7 41125 Donald Pengorest where a bi expandable metal control device is used for control. Further US patent #4219967 Hickerson, relies on a wick system as well. Capillary wicks are used in many growing devices however controlling the moisture they deliver is not easily achieved, leaving soil saturated and unhealthy. There for it is the purpose of this invention to control air and moisture delivery through a specifically designed nozzle that removes the need for electronic equipment for regulating moisture levels.

#### BRIEF DESCRIPTION OF DRAWINGS

[0004] Fig. 1 Shows nozzle for vertical system (1) and nozzle with collar (6) for positioning nozzle in the correct depth. (2) shows air channel for moving air through (1) nozzle. Pot collar (7) holds pot the proper distance from channel. Recessed air channel (5) ends 1/8-1/4 inch from nozzle opening to insure negative pressure build up in nozzle (1 ,2).

[0005] Fig. 2 Shows a straight nozzle (1) for horizontal growing channels with air channel (2) and (5) recessed air chamber.

[0006] Fig. 3 Demonstrates the nozzle (1) with fiberglass wick (4) inserted and (8) air flow out of tube from channel. Fig 8 (9, 13)to see channel.(5) shows recess in air chamber to create the negative pressure on the wick for water movement.

[0007] Fig. 4 Is a front look at nozzle (1) tube end shows the air channel/chamber (2) and nozzle end without the fiberglass wick.

[0008] Fig. 5 Demonstrates a straight nozzle (1) for horizontal applications with which (4) nozzle stop (6) and air flow out of nozzle (8).

[0009] Fig. 6 Is a side view of horizontal panel (15) showing nozzles (1) seated into channel with which (4) hanging in irrigation water (17) Irrigation water needs to be 2 inches from base of nozzle (1, 18) for process to work properly.

[0010] Fig. 7 is a front cut away look at a horizontal channel (15) showing irrigation water (17) and distance between irrigation water and nozzle base (18).

[0011] Fig. 8 Shows a cross section of air channel (9) with planting pot (12) pot is hanging on rail (19) and seated into nozzle (1) wick (4) is hanging in irrigation water (11) with the two inch space (18) between the bottom of nozzle (1) and irrigation water (11) Air and moisture from channel (9) move into the soil with microbes (14) Clean remediated air leave planting pot (12) from top of pot bathing plant in humid air (16). As shown in Figure 8, the nozzle extends from a respective planting pot to a respective channel.

[0012] Fig. 9 depicts the embodiment of Fig. 8 having connected chambers that contain indoor air and a small reservoir of water.

#### DETAILED DESCRIPTION

[0013] Water/air delivery system for vertical and horizontal plantings that enables water, air and heat (if needed) delivery through a single pressurized system in conjunction with a targeted delivery nozzle designed to efficiently combine air and water in tandem while keeping soil sub-straight adequately moist for plant and microbe growth . This system enables High air volumes to be pumped through root zones enhancing the process of Phytoremediation. System is

scalable for small consumer growing system and to large commercial applications. This system eliminates the need for separate water drainage/reservoir catch basins, electronic sensing or timers for watering. This system also conserves energy with targeted nozzles that deliver water, air and optional heat to each growth container. Nozzles can be removed from the system when not in use so no energy or water will be used. Nozzle uses absorptive wick but does not rely on capillary action for moving moisture, rather uses air flow targeted directly behind wick end to propel moisture into growing container soil medium from a "negative" pressure created within the nozzle. Thus the purpose of this system is to adequately provide air and water to a US provisional patent 61/849,339 plants roots for air cleaning while keeping water for irrigating the system isolated from rooms interior.

[0014] This system embodies connected chambers (figure 9) that contain indoor air and a small reservoir of water(17) and (11) that can either be fed continuously or intermittently with a pump or direct water feed using a solenoid and a timer. Nozzle placement in the system is critical (1) and needs to be set into the system so water does not mix with the nozzle system. Only air enters the nozzle which in turn creates a negative pressure via the recessed air channel (5) which draws the water into the substrate.

[0015] The growing apparatus may be for cleansing air and watering plants, wherein the apparatus includes a modular panel constructed for either vertical or horizontal planting systems (Fig. 9), including connecting couplers and end caps for directing water flow from upper to lower channels (22). For example, a first channel may be located vertically higher than a second channel. The second channel may include a drain as discussed in more detail below. The panel consist of 5 channels per section with opposing conical top and bottom set at 45 degree

angles (23) for both channeling water and accepting irrigation nozzle. Note, system can also use a horizontal channel system (as fig.7 and 8 demonstrate) while the orientation is different they function is the same. Panels (24) stack nesting consecutively on top of each other to make larger systems (Fig.9) Panels may have an attached rail (19) for accepting and hanging planting container.

[0016] The panel may have ports for accepting "air" (21) and "water" (20 ) from external fan or blower as well as drain (26) located at the bottom of the last run for draining the system. End connecting caps may extend upwards into the bottom of channel (27) restricting and holding water in base of channel as well as channel within the end cap for directing water flow to the bottom of next consecutive channel. Air ports (21) at the top of the air chambers (2) may be for the purpose of air direction forced in a downward flow to alleviate water and air "mixing" within the nozzle. The system creates separation of irrigation water in channel (11 ) from soil substrate (10) by positive pressure within said channel (13) insuring no mixing of the irrigation water (11) and planting medium (10) occurs. The system creates separation of the irrigation water in channel (11) from the soil sub straight (10) by positive pressure within said channel (fig.8-13) insuring that no mixing of the irrigation water (fig.8-11) and planting medium.

[0017] The system may use a wicking system/nozzle (1) spaced from distance of 2-3 inches from the water level (11) to the base of the nozzle holding wick in center of channel to insure no mixing of water and air occur. The nozzle may use a separate air chamber (2) for efficiently moving air out of said chamber (28) without extreme pressure build up. The system utilizes said nozzle and air chamber (2) that is recessed back 1/8-1/4 inch to direct air volume over end of exposed wick to facilitate water movement into soil rooting media Wherein without

directed air movement over said wick moisture movement would not occur. The system uses air movement through said air chamber (2) into said nozzle as a means for irrigating a plant.

[0018] For example, as shown in Figure 8, the nozzle 1 extends from the planting pot 12 to the channel 11. More specifically, a first portion of the nozzle 1 and of the wick 4 is located in the channel 11 while a second opposite portion of the nozzle 1 and of the wick 4 is located in the planting pot. The first portion of the wick 4 may contact water within the channel 11. As shown in Figures 3 and 4, air flow from the channel 11 may pass through the nozzle 1, via the air chamber 2 and recessed air channel 5, into the planting pot 12 (see Figure 8). As discussed above, this air flow may facilitate moisture movement from the channel 11 into the planting pot 12 through the wick 4.

What is Claimed:

1. A growing apparatus for cleansing air and watering a plant comprising:  
a modular panel having a rail, a plurality of planting pots, a plurality of channels including a first channel and a second channel, an air port and a water port,  
wherein each channel has an opposing conical top and bottom to channel water and accept a nozzle having a wick and a recessed air chamber, wherein the nozzle extends from a respective planting pot to a respective channel, wherein the air port is located at the top of at least one respective channel, wherein the water port is located at the bottom of at least one respective channel, and wherein the wick extends into a respective planting pot of the plurality of planting pots; and  
an end cap configured to direct water flow from the first channel to the second channel, wherein said end cap restricts and holds water within the first channel and directs water flow to the bottom of the second channel; and  
a fan connected to the air port, wherein the fan provides an air flow behind the wick and a negative pressure of the air flow within the nozzle propels the water flow through the wick.
2. The apparatus of claim 1, wherein the nozzle is spaced a distance of 2 to 3 inches above a water level to ensure no mixing of water and air occur.
3. The apparatus of claim 1 wherein, the nozzle directs a volume of air over an end of the wick to facilitate water movement into a soil rooting media.
4. The apparatus of claim 1, wherein movement of air through said recessed air chamber into said nozzle irrigates the plant.
5. The apparatus of claim 1, wherein the air port forces air flow in a downward direction to alleviate a mix water and air within the nozzle.

6. The apparatus of claim 1, wherein the modular panel comprises a plurality of sections and each section of the modular panel consists of five channels per section.

7. The apparatus of claim 1, wherein an orientation of the plurality of channels is horizontal.

8. The apparatus of claim 1, comprising more than one modular panel stacked vertically.

9. A system for cleansing air and watering a plant comprising:

a modular panel having a rail, a plurality of channels including a first channel and a second channel, a fan connected to an air port, a water port connected to a water feed, wherein each channel of the plurality of channels has an opposing conical top and bottom; and

a planting pot hung from the rail, said planting pot seated on a nozzle having a recessed air chamber and a wick, wherein the fan connected to the air port provides an air flow behind the wick, wherein the air flow creates negative pressure within the nozzle and propels water from the water port and the water feed through the nozzle into the planting plot, wherein at least one respective channel accepts the nozzle, wherein the air port is located at the top of at least one respective channel and wherein the water port is located at the bottom of at least one respective channel.

10. The system of claim 9, further comprising a pump for directing the water feed into the water port, wherein air entering the air port flows downward, preventing air and water from mixing in the nozzle.

11. The system of claim 9, wherein the first channel is vertically higher than the second channel and further comprising end caps configured to direct a flow of water from the first channel to the second channel.

12. The system of claim 11, wherein the second channel includes a draining system.

13. The system of claim 11, wherein the nozzle is spaced 2 to 3 inches from the water level to ensure no mixing of air and water occurs.

14. A plant growing apparatus comprising:

a body defining a pressurized channel, wherein:

the pressurized channel comprises a top portion and a bottom portion,  
and

the bottom portion of the pressurized channel is configured to store water; a fan configured to introduce air into the top portion of the pressurized chamber through an air port in communication with the pressurized chamber;

a wick;

a planting pot; and

a nozzle with a recessed air chamber, the nozzle having (i) a first end in which the wick is received and (ii) a second end that extends into the planting pot, wherein:

a portion of the wick is configured to be submerged in the water, and the first end of the nozzle is configured to be placed at a distance from the water

such that introduction of air into the top portion of the pressurized channel by the fan provides air flow within the nozzle and causes at least a volume of the water to be transported from the pressurized channel to the planting pot through the nozzle.

15. The apparatus of claim 14, wherein the distance ranges from 2 to 3 inches above the volume of the water.

16. The apparatus of claim 14, wherein:

the planting pot is configured to store soil rooting media; and

the nozzle comprises an air channel that is configured to direct a volume of air from the

pressurized channel to the soil rooting media such that directing the volume of air through the air channel facilitates transport of the volume of the water from the pressurized channel to the planting pot through the nozzle.

17. The apparatus of claim 16, wherein the transport of the volume of water from the pressurized channel through the nozzle irrigates a plant stored in the planting pot.

18. The apparatus of claim 14, wherein the fan is configured to introduce air into the top portion of the pressurized channel by flowing air in a downward direction from the top portion of the pressurized channel to the bottom portion of the pressurized channel.

19. A system for cleansing air and watering a plant, the system comprising:

a plurality of planting pots;

a panel having a body defining a pressurized channel that is configured to store water;

an air port in communication with the pressurized channel; and

a fan configured to deliver air into the pressurized channel through the air port;

wherein the panel comprises:

a plurality of wicks;

a plurality of nozzles each having a recessed air channel, wherein each nozzle has (i) a first end in which is received a wick from among the plurality of wicks and (ii) a second end that extends into a planting pot

from among the plurality of planting pots, wherein:

a portion of each wick from the plurality of wicks is configured to be submerged in the water, and

the first end of the plurality of nozzles is configured to be placed at a distance from the water such that introduction of air into the pressurized channel by the fan provides air flow within the plurality of nozzles and causes at least a volume of water from the pressurized channel to be transported to the plurality of planting pots through the plurality of wicks.

20. The system of claim 19, further comprising:

a water port in communication with the panel;

a pump configured to introduce water into the pressurized channel through the water port.

21. The system of claim 20, further comprising:

a draining system that is configured to remove a volume of water from the pressurized channel.

22. The system of claim 19, wherein the distance ranges from 2 to 3 inches above the water.

23. The system of claim 19, wherein:

each planting pot included in the plurality of planting pots is configured to store soil rooting media; and

each recessed air channel is configured to direct a volume of air from the pressurized channel to the soil rooting media such that directing the volume of air through the air channel facilitates transport of the volume of the water from the pressurized channel to the plurality of planting pots through the plurality of nozzles.

24. The system of claim 23, wherein the transport of the volume of water from the pressurized chamber through the plurality of nozzles irrigates a plurality of plants stored in the plurality of planting pots.

25. The system of claim 19, wherein the air port is configured to introduce air into the pressurized channel by flowing air in a downward direction from a top portion of the pressurized channel to a bottom portion of the pressurized channel.

26. A plant growing apparatus, comprising:

a body defining a pressurized chamber, wherein:

the pressurized chamber comprises a top portion and a bottom portion, and

the bottom portion of the pressurized chamber is configured to store water;

a wick defining a volume;

a fan configured to introduce air into the top portion of the pressurized chamber through an air port in communication with the pressurized chamber;

a planting pot; and

a nozzle having a recessed air channel, wherein the nozzle has (i) a first end in which the wick is received and (ii) a second end that extends into the planting pot, wherein:

a portion of the wick is configured to be submerged in the water, and

the first end of the nozzle is configured to be placed at a distance from the water such that introduction of air into the top portion of the pressurized chamber by the fan provides air flow within the nozzle and causes at least a

volume of the water to be transported from the pressurized chamber to the planting pot through the wick .

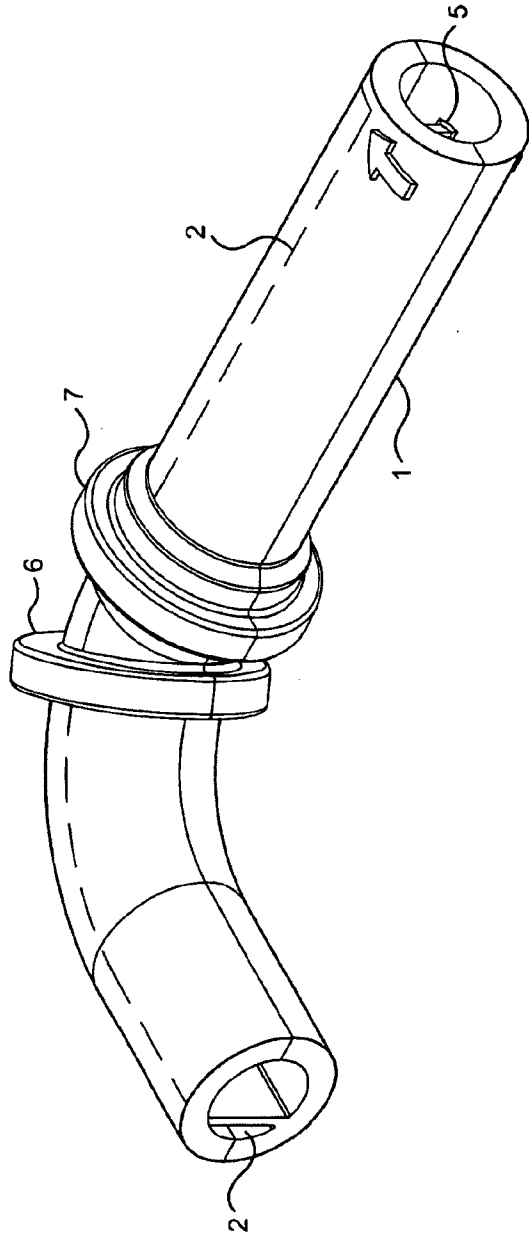

Fig. 1

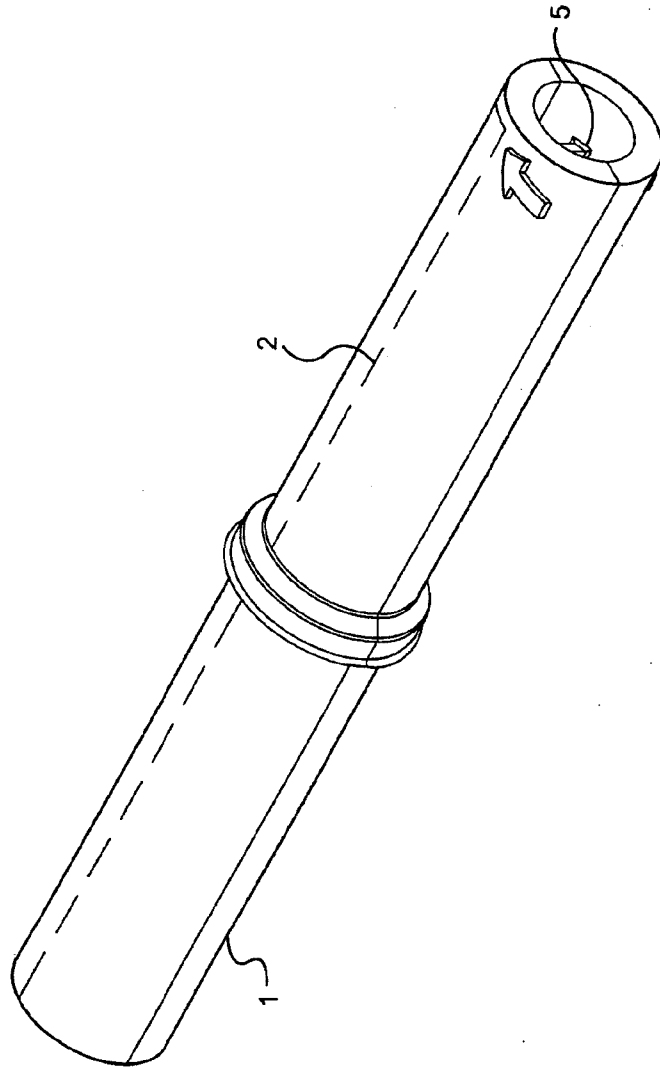

Fig. 2

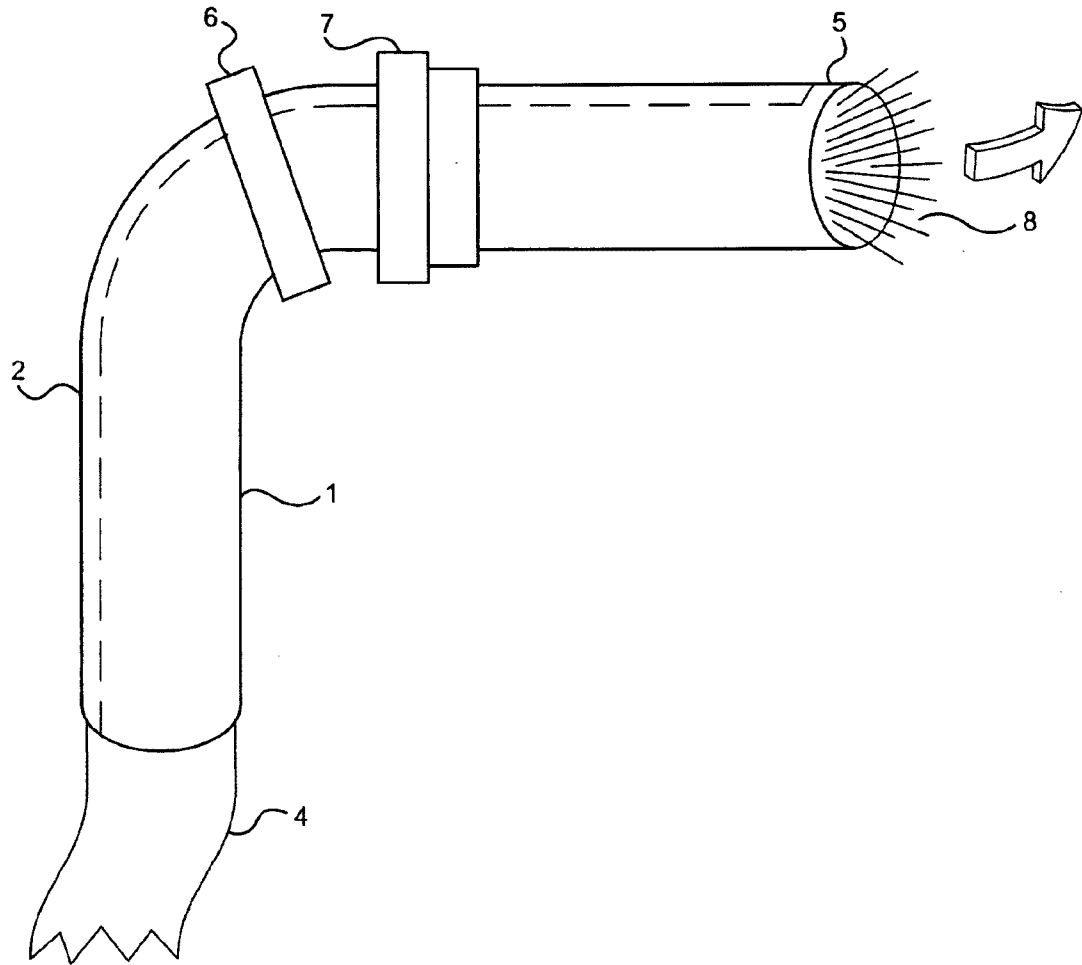

Fig. 3

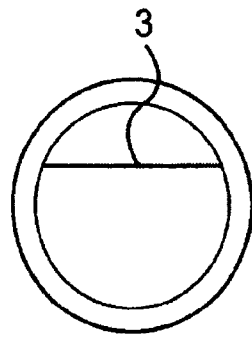

Fig. 4

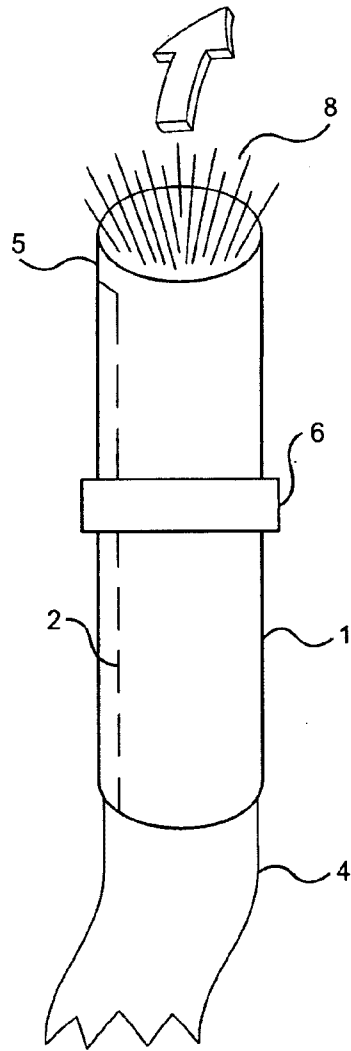

Fig. 5

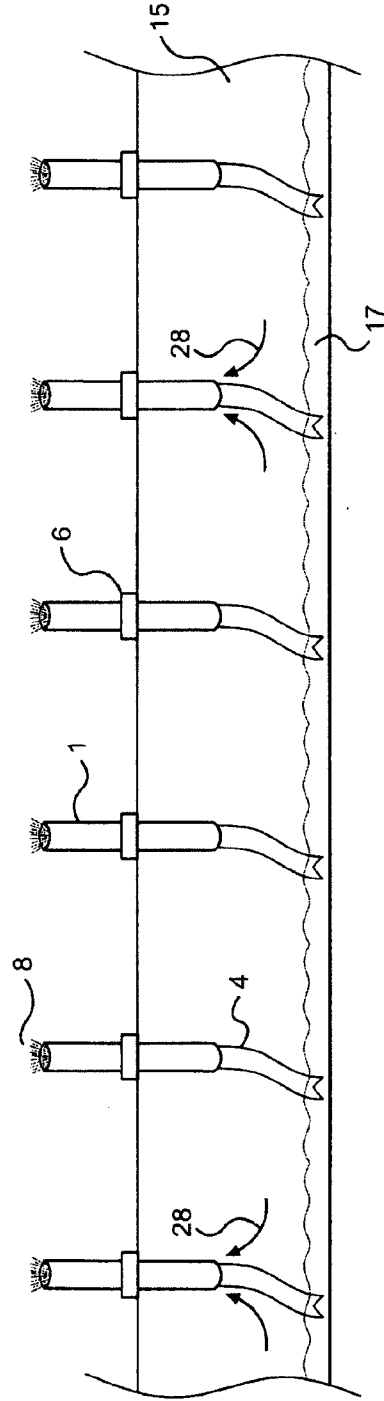

Fig. 6

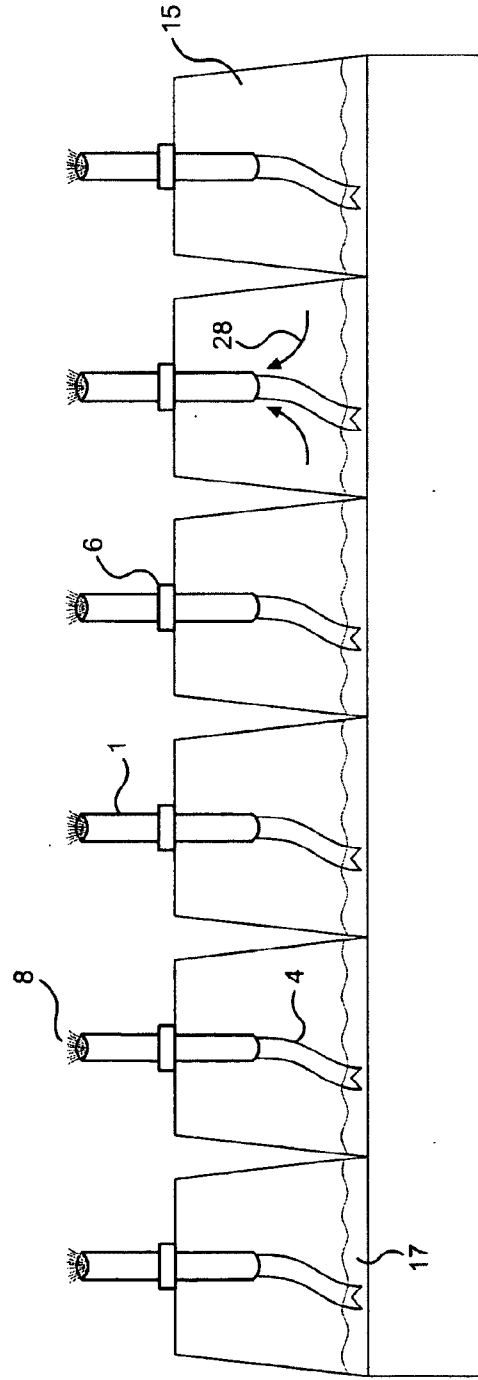

Fig. 7

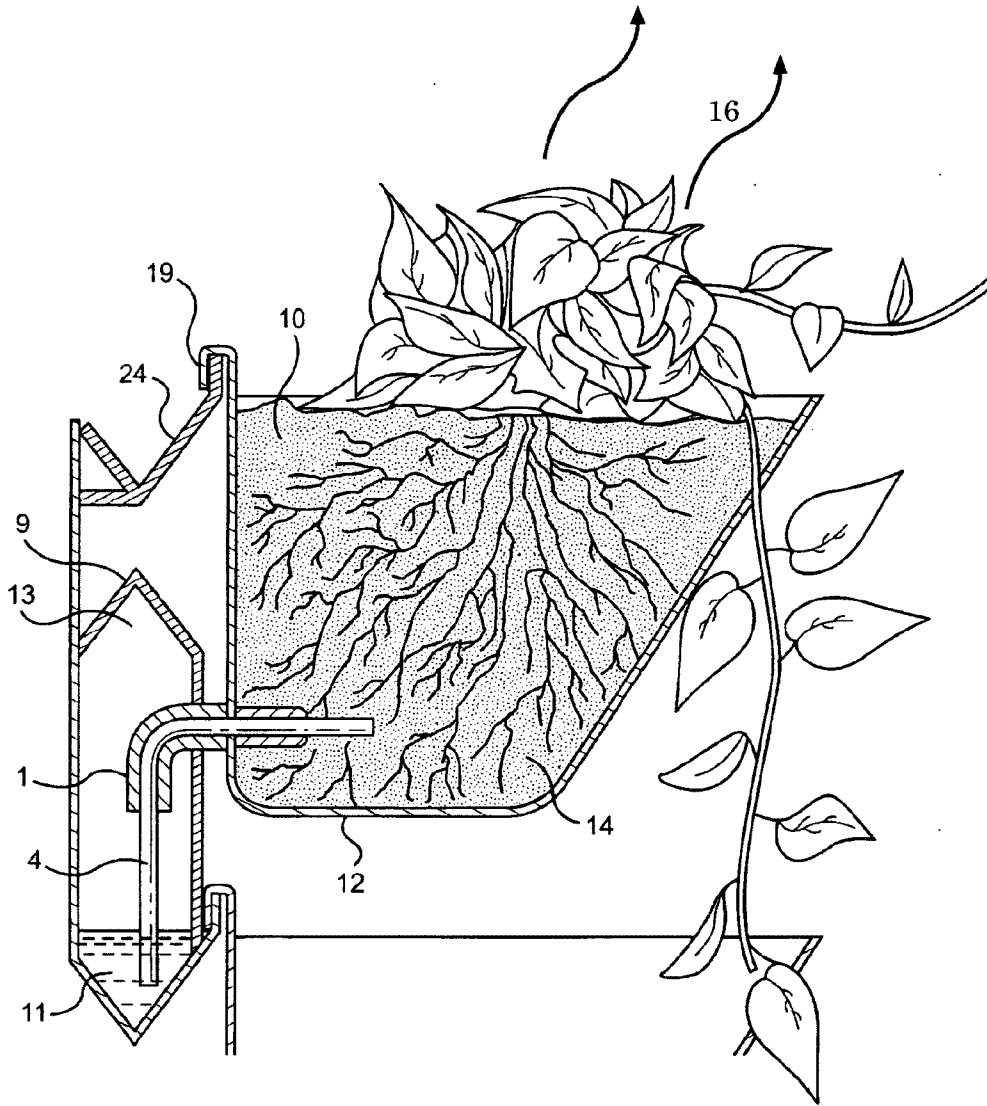

Fig. 8

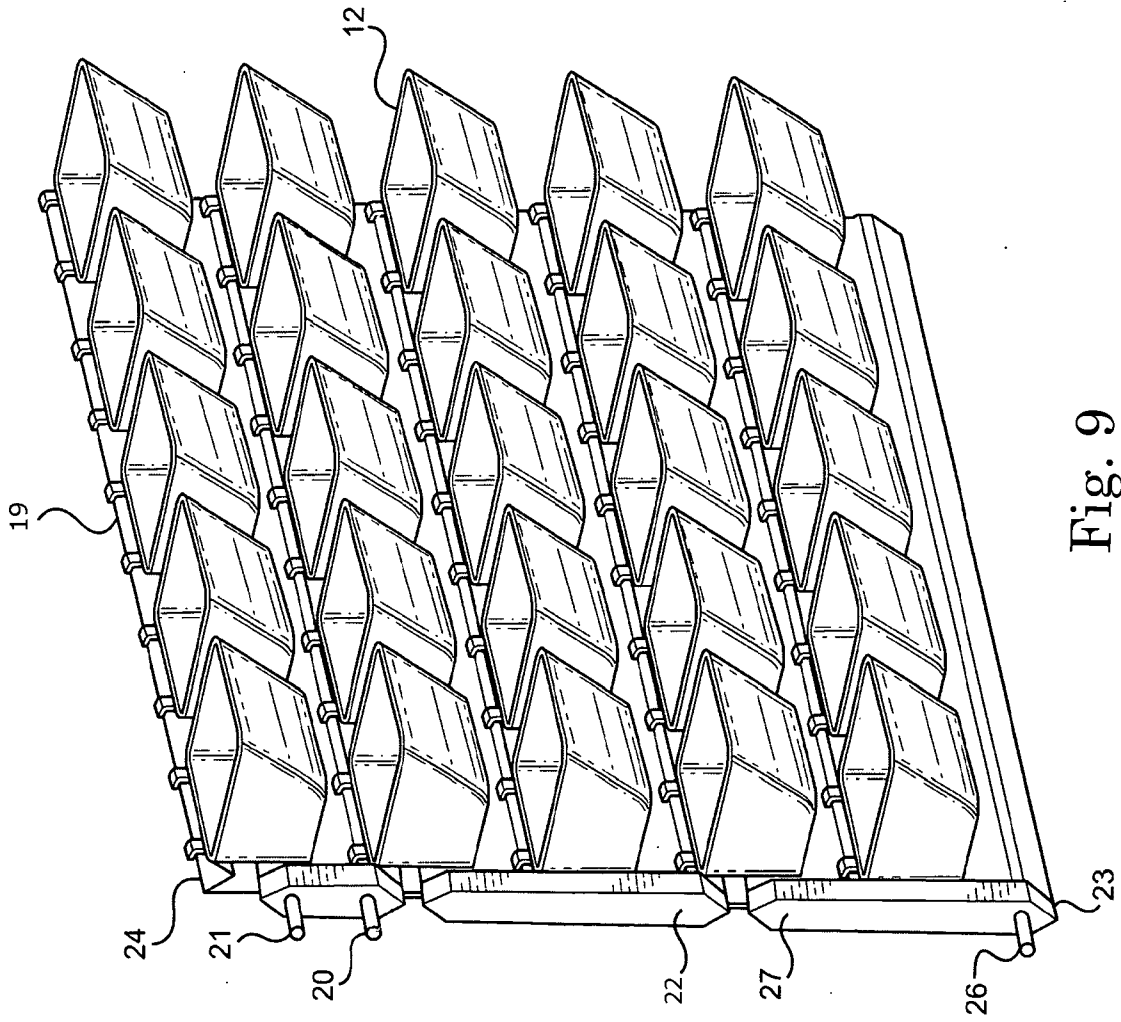

Fig. 9

