



(11) **EP 3 649 880 B1**

(12) **EUROPEAN PATENT SPECIFICATION**

(45) Date of publication and mention of the grant of the patent:
27.12.2023 Bulletin 2023/52

(51) International Patent Classification (IPC):
A43B 1/00^(2006.01) A43B 17/00^(2006.01)

(21) Application number: **19207127.2**

(52) Cooperative Patent Classification (CPC):
A43B 1/0054; A43B 17/00

(22) Date of filing: **05.11.2019**

(54) **FOOTWEAR WITH INSOLE WITH VARIABLE MAGNETIC FIELD**

SCHUH MIT EINLEGESOHLE MIT VARIABLEM MAGNETFELD

CHAUSSURE AVEC SEMELLE A CHAMP MAGNETIQUE VARIABLE

(84) Designated Contracting States:
AL AT BE BG CH CY CZ DE DK EE ES FI FR GB GR HR HU IE IS IT LI LT LU LV MC MK MT NL NO PL PT RO RS SE SI SK SM TR

(30) Priority: **07.11.2018 IT 201800010107**

(43) Date of publication of application:
13.05.2020 Bulletin 2020/20

(73) Proprietor: **Industrial Wear Srl**
47016 Predappio (FC) (IT)

(72) Inventor: **MISSOLI, Franco**
20081 Abbiategrasso (MI) (IT)

(74) Representative: **Corradini, Corrado et al**
Ing. C. Corradini & C. S.r.l.
Via Dante Alighieri 4
42121 Reggio Emilia (IT)

(56) References cited:
DE-U1- 8 604 470 JP-A- 2001 178 833
US-A- 5 685 094 US-A1- 2012 304 500

EP 3 649 880 B1

Note: Within nine months of the publication of the mention of the grant of the European patent in the European Patent Bulletin, any person may give notice to the European Patent Office of opposition to that patent, in accordance with the Implementing Regulations. Notice of opposition shall not be deemed to have been filed until the opposition fee has been paid. (Art. 99(1) European Patent Convention).

DescriptionTECHNICAL FIELD

[0001] The present invention relates to an insole, and more particularly the invention relates to an insole equipped with means adapted to generate a variable magnetic field and footwear equipped with such insole.

PRIOR ART

[0002] It is known that the correct functioning of the human body is based on the maintenance of delicate internal balances, which if altered can lead to undesirable effects such as pain and fatigue.

[0003] Two important aspects that contribute, together with others, to the performance of all the functions of the body are blood circulation, through which energy is transported to all the cells of the body and toxins are simultaneously eliminated, and cellular metabolism.

[0004] In particular, cellular metabolism is based on cellular transmembrane ion balance, which is responsible for membrane electrical potential, maintained thanks to the transport of ions through the cell membrane by means of a series of different transport mechanisms, the most important and well-known surely being the sodium-potassium pump.

[0005] This electrical membrane potential allows, among other things, the propagation of transient electrical signals in cells of excitable tissues, in particular in cells in which it is subject to sudden changes such as muscle and nerve cells, so as to transmit information that may be of vital importance to a living organism rapidly and via long distances.

[0006] During everyday activities the human body is subjected to various types of stress, in particular mechanical stress due to the execution of specific movements or sudden stresses such as bruises, which alter the aforementioned balances of the body, including precisely correct blood circulation and normal cellular metabolism.

[0007] In order to restore normal cellular conditions, and body conditions in general, various types of treatments are known, for example specific treatments adapted to act on specific body areas, probably the most widespread and known of which is acupuncture.

[0008] Among the various body areas, a treatment area of particular interest is the plantar area.

[0009] In fact, this area is particularly stressed during the day, firstly because it is adapted to support the full weight of the human body, especially in cases of prolonged states in an upright position, and secondly because it is mechanically stressed by wearing shoes, especially in the case of safety shoes which are particularly rigid.

[0010] In this context, there are two types of treatments that have been spreading in recent years, which are known as plantar reflexology and plantar magnetotherapy.

[0011] Plantar reflexology envisages acting with pressure, known as acupressure or finger pressure when done manually, on the sole of the foot and particularly in the area/s where pain is present.

[0012] This pressure stimulates the lymphatic system, with the consequent acceleration of lymphatic circulation with benefits on the whole organism.

[0013] This pressure also stimulates the blood system with the purpose of improving circulation, thereby favouring the disposal of waste.

[0014] Specifically, this pressure mainly acts on the return circulatory system, i.e. on the venous system, acting as a peristaltic pump.

[0015] The second type of treatment, plantar magnetotherapy, is based on the concept that the application of magnetic fields to the human body can positively stimulate cellular action by restoring its metabolism, as documented by hundreds of scientific studies.

[0016] In particular, the application of these magnetic fields allows the restoration of the transmembrane ion balance and therefore the aforementioned membrane electrical potential, altered for example and as mentioned by mechanical stress, thereby restoring cellular metabolism and therefore cellular functions, and in some cases accelerating them (for example in the magnetic stimulation treatments for bone regrowth). These types of treatments generally require the assistance of highly qualified personnel and/or particularly expensive treatment devices.

[0017] They simultaneously require time, due both to the need to go to specialized facilities, and for the time taken to perform the treatment itself.

[0018] In order to obviate the aforesaid drawbacks, insoles are known on the market which are equipped with permanent magnets, which are completely inserted inside the thickness of the insole without changing the resting surface of the foot.

[0019] The magnetic field generated by the permanent magnets of said insoles always has the same orientation and therefore has a limited effectiveness in the magnetotherapeutic stimulation of the foot.

[0020] Such a solution is for example described in US2012304500 that discloses a shoe sole insert base and a plurality of magnets embedded and fixed within the shoe sole insert base, each one with a respective fixed orientation.

[0021] An object of the present invention is therefore to provide an insole with magnetic effects for the more effective plantar stimulation of the known devices.

[0022] A further object of the present invention is to provide an insole which is simultaneously able to exert a stimulating acupressure action on the sole of the foot.

[0023] A further object is to achieve the aforementioned objectives in the context of a rational, effective and low-cost solution.

[0024] Such purposes are accomplished by the characteristics of the invention given in the independent claim. The dependent claims outline preferred and/or

particularly advantageous aspects of the invention.

DISCLOSURE OF THE INVENTION

[0025] In particular, the invention provides an insole, comprising:

- a supporting body adapted to support by resting the sole of a foot, and
- a housing seat formed in the supporting body,

wherein the permanent magnet is inserted movably and loosely inside an internally hollow containment body inserted into the housing seat in the supporting body.

[0026] Thanks to this solution, the invention provides an insole for a magnetotherapy treatment, and therefore a treatment device that can be worn during daily activities, and which, thanks to the mobility of the permanent magnet inside the housing seat, provides a variable magnetic field at the foot which is more effective in the stimulation of the same.

[0027] It is specified that with the term movable it is intended that the permanent magnet is freely movable inside the housing seat, i.e. freely movable rotatably and/or slidingly in any direction within the housing seat.

[0028] In other words, the permanent magnet can rotate and/or roll and/or translate in any direction inside the housing seat and with respect to the housing seat itself.

[0029] Then, moving the insole, the permanent magnet inserted in the housing seat realized in the supporting body of the insole itself, can freely move (and therefore rotate and/or roll and/or translate and/or hop within the housing seat) and arrange itself randomly in any position and in any orientation within the housing seat, and therefore the permanent magnet can move inside the housing seat without rigidly following the movement of the insole.

[0030] According to the invention the permanent magnet preferably comprises a magnetic sphere.

[0031] Thanks to this solution the permanent magnet is easily moved, and with reduced friction, inside the housing seat during the movements of the foot.

[0032] According to the invention the magnetic sphere preferably comprises two hemispheres which are polarized inversely to one another.

[0033] Thanks to this solution, the magnetic sphere is movable inside the housing seat, and by rolling it is arranged towards the foot alternately with the positively polarized hemisphere or with the negatively polarized hemisphere, thereby providing a pulsed magnetic field at the foot, and in this way producing even more efficient stimulation of the foot itself.

[0034] According to the invention the magnetic sphere preferably has a diameter comprised between 2 mm and 5 mm.

[0035] Thanks to this solution, the magnetic sphere has a smaller footprint, and is therefore particularly adapted to being inserted into the supporting body of the insole. According to the invention the permanent magnet

is preferably made of a material comprising Neodymium, Iron and Boron.

[0036] Thanks to this solution, the magnetic element is particularly durable and is adapted to generate a permanent magnetic field that is particularly stable over time.

[0037] According to the invention the permanent magnet is preferably equipped with a chromium-plated surface treatment.

[0038] Thanks to this solution, the permanent magnet is protected from the phenomenon of oxidation that can occur when placed in a humid environment, as can be that of footwear, for example due to perspiration.

[0039] According to the invention the permanent magnet preferably generates a permanent magnetic field of an intensity comprised between 65 Gauss and 85 Gauss.

[0040] Thanks to this solution, the permanent magnet generates a magnetic field of particular intensity and therefore adapted to effectively stimulate the foot.

[0041] According to the invention the containment body is preferably equipped with a rounded upper infill wall adapted to protrude above a resting surface of the supporting body.

[0042] Thanks to this solution, the upper wall of the infill is adapted to contact the sole of the foot resting on the insole, performing an acupuncture action on the sole of the foot itself.

[0043] The invention further provides a footwear comprising an insole as described above. Thanks to this solution, the invention provides footwear which can be worn during daily activities, equipped with an insole with the aforesaid characteristics and therefore with the advantages connected thereto.

[0044] According to the invention the insole is preferably made integrally with a sole of the shoe.

[0045] Thanks to this solution, the footwear equipped with the insole can be made through a particularly rapid and low-cost production process.

BRIEF DESCRIPTION OF THE DRAWINGS

[0046] Further characteristics and advantages of the invention will become clear from reading the following description provided as a non-limiting example, with the help of the figures illustrated in the attached tables.

Figure 1 is a view from above of an insole according to the invention.

Figure 2 is a partial sectional view of footwear equipped with an insole according to the invention.

Figure 3 is a sectional view of a first embodiment of the insole according to the invention.

Figure 4 is an enlarged view of a portion of figure 3. Figure 5 is a sectional view of a second embodiment of the insole according to the invention.

Figure 6 is an enlarged view of a portion of figure 5. Figure 7 is a sectional view of a third embodiment of the insole according to the invention.

Figure 8 is an enlarged view of a portion of figure 7.

BEST WAY TO ACTUATE THE INVENTION

[0047] With particular reference to these figures, an insole is globally indicated with the number 10.

[0048] The insole 10 comprises a supporting body 15 adapted to support by resting the sole of a foot.

[0049] In particular, the supporting body 15 provides an upper resting surface 20 adapted to be placed in direct or indirect contact with the sole of the foot.

[0050] In the example, the insole 10 is of the integral type, i.e. the supporting body 15 has a heel portion adapted to support by resting an area of the rearfoot, a tip portion adapted to support a forefoot area and a central portion, interposed between the heel portion and the tip portion, and adapted to support a midfoot area.

[0051] However, it is not excluded that in alternative embodiments, the insole 10 can be of the partial type, i.e. the supporting body 15 can lack one or more of the aforesaid portions.

[0052] The supporting body 15 is made of flexible or semi-flexible material.

[0053] For example, the supporting body 15 can be made of ethylene vinyl acetate, cork, PPT or another suitable material.

[0054] Said supporting body 15 can have a homogeneous or non-homogeneous thickness along its extension, and can have a maximum thickness comprised between 5 mm and 12 mm, preferably having a maximum thickness of 8 mm.

[0055] The insole 10 further comprises a permanent magnet 25 adapted to generate a permanent magnetic field.

[0056] In detail, the insole 10 comprises a permanent magnet 25 equipped with at least two polarized portions which are mutually inverse, i.e. equipped with at least one positively polarized portion and at least one negatively polarized portion.

[0057] The permanent magnet 25 is adapted to generate a magnetic field, for example of an intensity between 65 and 85 Gauss, preferably a magnetic field of 75 Gauss.

[0058] Said permanent magnet 25 is, for example, made of a material comprising Chromium, Neodymium and Boron, however it can also be made of another magnetic material adapted to generate a permanent magnetic field.

[0059] Preferably, the permanent magnet 25 is further equipped with a surface treatment, for example a chromium treatment, thanks to which the permanent magnet 25 is protected from an undesired oxidation phenomenon which could occur in the presence of moisture.

[0060] In the preferred embodiment, the permanent magnet 25 comprises (i.e. is constituted by) a magnetic sphere equipped with two hemispheres 30,35 which are mutually inversely polarized, i.e. a magnetic sphere comprising a positively polarized hemisphere 30 and a negatively polarized hemisphere 35.

[0061] For example, the magnetic sphere has a diam-

eter comprised between 2 mm and 5 mm, preferably the magnetic sphere has a diameter of 3 mm.

[0062] The permanent magnet 25 (i.e. the magnetic sphere) is directly or indirectly inserted and housed inside a housing seat S open above, formed in the supporting body 15 of the insole 10 and movable (loosely) inside the same, the housing seat S being substantially defined by a cavity open upwards formed in the supporting body 15 itself.

[0063] It is specified that with the term movable it is intended that the permanent magnet 25 is freely movable inside the housing seat S, i.e. freely movable rotatably and/or slidingly in any direction within the housing seat S.

[0064] In other words, the permanent magnet 25 can rotate and/or roll and/or translate in any direction inside the housing seat S and with respect to the same (remaining however contained inside the housing seat S).

[0065] Then, moving the insole 10, the permanent magnet 25 inserted in the housing seat S realized in the supporting body 15 of the insole itself, can freely move (and therefore rotate and/or roll and/or translate and/or hop within the housing seat S) and arrange itself randomly in any position and in any orientation within the housing seat S, and therefore the permanent magnet 25 can move inside the housing seat S without rigidly following the movement of the insole 10.

[0066] For example, the housing seat S is formed in the central portion of the supporting body 15, however it can also be formed in the heel portion or in the tip portion.

[0067] It is also possible that the insole 10 can comprise multiple permanent magnets 25, each inserted (directly or indirectly) movably in a suitable housing seat S formed in the supporting body 15, and that the housing seats S can be formed at different portions of the supporting body 15 itself, or furthermore several housing seats S can be present for the same number of permanent magnets 25 in each portion of the supporting body 15.

[0068] In a first embodiment, shown in figures 3 and 4, the permanent magnet 25 is inserted directly into the housing seat S, i.e. in a complete stasis condition the permanent magnet 25 is in direct contact with at least one internal surface of the cavity formed in the supporting body 15 of the insole 10, which defines the housing seat S.

[0069] In this first embodiment, the supporting body 15 has a surface film F, which defines at least one portion of the resting surface 20, adapted to close the housing seat S above so as to keep the permanent magnet 25 contained within it.

[0070] The surface film F has an extension such to at least completely occlude the housing seat S above.

[0071] For example, it can be envisaged that such surface film F has an extension which is homologous to the extension of the supporting body 15, and which therefore defines the resting surface 20 itself.

[0072] In this way, the surface film F defines, with the housing seat S, a housing cavity for the permanent mag-

net 25 which is closed above.

[0073] In particular, this housing cavity has a volume comprised between 25 and 50 times the volume of the permanent magnet.

[0074] In this way the permanent magnet 25 has a high amount of space available for movement and is thus able to stimulate a wider area of the foot with its magnetic field, and at the same time provides a variable magnetic field at the foot itself.

[0075] Simultaneously, by moving within such a large space for movement, the permanent magnet 25 varies its orientation by arranging itself towards the sole of the foot alternately with the positively polarized portion or with the negatively polarized portion, providing a pulsed magnetic field at the foot.

[0076] The surface film F is made of a flexible material, for example it can be made of a polymer-based gel, but it can also be made of any other suitable flexible material.

[0077] In a second embodiment, shown in figures 5 and 6, the permanent magnet 25 is inserted movably (loosely) inside a containment body 40 open above and internally hollow, the containment body 40 being measurably inserted in the housing seat S formed in the supporting body 15 of the insole 10.

[0078] The containment body 40 is fixed to the housing seat S, for example by interference or by an adhesive or other means.

[0079] Said containment body 40 is made of rigid, non-magnetic material, for example plastic, and can have a substantially cylindrical shape.

[0080] For example, the containment body 40 can have an outer diameter comprised between 15 mm and 25 mm, preferably having an outer diameter of 20 mm.

[0081] In this embodiment, the supporting body 15 has a surface film F, which defines at least one portion of the resting surface 20, adapted to close the containment body 40 above so as to keep the permanent magnet 25 contained within it.

[0082] The surface film F has an extension such that at least completely occlude the containment body 40 above.

[0083] For example, it can be envisaged that such surface film F has an extension which is homologous to the extension of the supporting body 15, and which therefore defines the resting surface 20 itself.

[0084] In this way, the surface film F defines, with the containment body 40, a housing cavity for the permanent magnet 25 which is closed above.

[0085] In particular, this housing cavity has a volume comprised between 30 and 45 times the volume of the permanent magnet.

[0086] In this way the permanent magnet 25 has a high amount of space available for movement and is thus able to stimulate a wider area of the foot with its magnetic field, and at the same time provides a variable magnetic field at the foot itself.

[0087] Simultaneously, by moving within such a large space for movement, the permanent magnet 25 varies its orientation by arranging itself towards the sole of the

foot alternately with the positively polarized portion or with the negatively polarized portion, providing a pulsed magnetic field at the foot.

[0088] In a third embodiment, shown in figures 7 and 8, the permanent magnet 25 is inserted movably (loosely) inside a containment body 40, internally hollow and closed above by an upper infill wall 45, the containment body 40 being measurably inserted in the housing seat S formed in the supporting body 15 of the insole 10.

[0089] The containment body 40 is fixed to the housing seat S, for example by interference or by an adhesive or other means.

[0090] In particular, the internal cavity of the containment body 15 has a volume comprised between 30 and 45 times the volume of the permanent magnet.

[0091] In this way the permanent magnet 25 has a high amount of space available for movement and is thus able to stimulate a wider area of the foot with its magnetic field, providing a more variable magnetic field at the same area.

[0092] Simultaneously, by moving within such a large space for movement, the permanent magnet 25 varies its orientation by arranging itself towards the sole of the foot alternately with the positively polarized portion or with the negatively polarized portion, providing a pulsed magnetic field at the foot.

[0093] In practice, the containment body 40 is inserted into the housing seat S, embedded (at least partially) inside the supporting body 15 and fixed thereto, for example by means of an adhesive.

[0094] Said containment body 40 is made of rigid, non-magnetic material, for example plastic, and can have a substantially cylindrical shape.

[0095] For example, the containment body 40 can have an outer diameter comprised between 15 mm and 25 mm, preferably having an outer diameter of 20 mm.

[0096] In particular, the upper wall 45 of the containment body 40 has a rounded shape. I.e., the containment body 40 is equipped with a concave upper wall 45, with the concavity facing the internal cavity of the containment body 40 itself.

[0097] The upper wall 45 is adapted to protrude (at least partially) beyond the resting surface 20 of the supporting body 15, so as to come into contact with the sole of the foot and be pressed against it, thus carrying out an acupressure action on the same sole. In this embodiment shown, the containment body 40 is embedded in the supporting body 15 so that the upper wall 45 is placed at a height which is higher than the height at which the resting surface 20 of the supporting body 15 is located.

[0098] In an alternative embodiment not shown, the containment body 40 can be embedded in the supporting body 15 so that the upper wall 45 is substantially flush with the resting surface 20 of the supporting body 15.

[0099] In this case, the foot resting on the insole 10 is adapted to compress the supporting body 15, consequently causing the upper wall 45 of the containment body 40 to protrude (at least partially) with respect to the

resting surface 20 of the supporting body 15, the upper wall 45 therefore being adapted to come into contact with the sole of the foot and be pressed against it, thus carrying out an acupuncture action on the sole itself.

[0100] An embodiment of the invention illustrated in figure 2 further provides footwear 50, for example safety shoes, equipped with an insole 10 as described above.

[0101] In this embodiment, the insole 10 is inserted inside the footwear 50 and superimposed on a sole 55 of the footwear 50 itself.

[0102] In an alternative embodiment not shown, the insole 50 can be formed integrally with the sole 55 of the footwear 50, or the insole 10 and the sole 55 can be formed in a single body.

[0103] For example, the supporting body 15 of the insole 10 and the sole 55 can be formed in a single body.

[0104] Alternatively, the insole 10 can be fixed to the sole 55 by means of an adhesive or by sewing.

[0105] It is specified that footwear 50 is intended as shoes, safety shoes, slippers and the like.

[0106] The materials used, as well as the contingent shapes and sizes, can be whatever according to the requirements without for this reason departing from the scope of protection of the following claims.

Claims

1. An insole (10), comprising:

- a supporting body (15) adapted to support by resting the sole of a foot, and
- a housing seat (S) formed in the supporting body (15),

the insole (10) being **characterized in that** a permanent magnet (25) is inserted movably and loosely inside an internally hollow containment body (40) inserted into the housing seat (S) formed in the supporting body (15).

2. The insole (10) according to claim 1, wherein the permanent magnet (25) comprises a magnetic sphere.

3. The insole (10) according to claim 2, wherein the magnetic sphere (25) comprises two hemispheres (30, 35) polarized inversely to one another.

4. The insole (10) according to claim 2, wherein the magnetic sphere (25) has a diameter comprised between 2 mm and 5 mm.

5. The insole (10) according to claim 1, wherein the permanent magnet (25) is made of a material comprising Neodymium, Iron and Boron.

6. The insole (10) according to claim 1, wherein the

permanent magnet (25) generates a permanent magnetic field of intensity comprised between 65 Gauss and 85 Gauss.

7. The insole (10) according to claim 1, wherein the containment body (40) is equipped with a rounded upper infill wall (45) adapted to protrude above a resting surface (20) of the supporting body (15).

8. A footwear (50) comprising an insole (10) according to claim 1.

9. A footwear (50) according to claim 8, wherein the insole (10) is made integrally with a sole (55) of the footwear (50).

Patentansprüche

1. Einlegesohle (10), umfassend:

- einen Stützkörper (15), der angepasst ist, um die Sohle eines Fußes durch Aufliegen zu stützen, und
- einen Aufnahmesitz (S), der in dem Stützkörper (15) gebildet ist,

wobei die Einlegesohle (10) **dadurch gekennzeichnet ist, dass** ein Permanentmagnet (25) beweglich und lose in einen innen hohlen Umschließungskörper (40) eingesetzt ist, der in den Aufnahmesitz (S) eingesetzt ist, der in dem Stützkörper (15) gebildet ist.

2. Einlegesohle (10) nach Anspruch 1, wobei der Permanentmagnet (25) eine Magnetkugel umfasst.

3. Einlegesohle (10) nach Anspruch 2, wobei die Magnetkugel (25) zwei zueinander umgekehrt polarisierte Halbkugeln (30, 35) umfasst.

4. Einlegesohle (10) nach Anspruch 2, wobei die Magnetkugel (25) einen Durchmesser zwischen 2 mm und 5 mm aufweist.

5. Einlegesohle (10) nach Anspruch 1, wobei der Permanentmagnet (25) aus einem Material gefertigt ist, umfassend Neodym, Eisen und Bor.

6. Einlegesohle (10) nach Anspruch 1, wobei der Permanentmagnet (25) ein Permanentmagnetfeld mit einer Stärke zwischen 65 Gauss und 85 Gauss erzeugt.

7. Einlegesohle (10) nach Anspruch 1, wobei der Umschließungskörper (40) mit einer abgerundeten oberen Füllwand (45) ausgestattet ist, die angepasst ist, um über eine Auflagefläche (20) des Stützkörpers

(15) hervorzustehen.

8. Schuhwerk (50), umfassend eine Einlegesohle (10) nach Anspruch 1.

5

9. Schuhwerk (50) nach Anspruch 8, wobei die Einlegesohle (10) einstückig mit einer Sohle (55) des Schuhwerks (50) gefertigt ist.

10

Revendications

1. Semelle intérieure (10) comprenant :

- un corps de support (15) adapté pour soutenir en reposant la plante d'un pied, et
- un logement (S) formé dans le corps de support,

15

la semelle intérieure (10) étant **caractérisée en ce qu'un aimant permanent (25) est inséré de manière mobile et lâche à l'intérieur d'un corps de confinement creux (40) inséré dans le logement (S) formé dans le corps de support (15).**

20

25

2. Semelle intérieure (10) selon la revendication 1, dans laquelle l'aimant permanent (25) comprend une sphère magnétique.

3. Semelle intérieure (10) selon la revendication 2, dans laquelle la sphère magnétique (25) comprend deux hémisphères (30, 35) polarisés inversement l'un par rapport à l'autre.

30

4. Semelle intérieure (10) selon la revendication 2, dans laquelle la sphère magnétique (25) dispose d'un diamètre dont la dimension varie entre 2mm et 5 mm.

35

5. Semelle intérieure (10) selon la revendication 1, dans laquelle l'aimant permanent (25) est fait d'un matériau comprenant du Néodyme, du Fer et du Bore.

40

6. Semelle intérieure (10) selon la revendication 1, dans laquelle l'aimant permanent (25) génère un champ magnétique permanent d'intensité compris entre 65 Gauss et 85 Gauss.

45

7. Semelle intérieure (10) selon la revendication 1, dans laquelle le corps de confinement (40) est équipé d'une paroi de remplissage supérieure arrondie (45) adaptée pour faire saillie au-dessus d'une surface de repos (20) du corps de support (15).

50

55

8. Chaussure (50) comprenant une semelle intérieure (10) selon la revendication 1.

9. Chaussure (50) selon la revendication 8, dans laquelle la semelle intérieure (10) est entièrement fabriquée avec une semelle (55) de la chaussure (50).

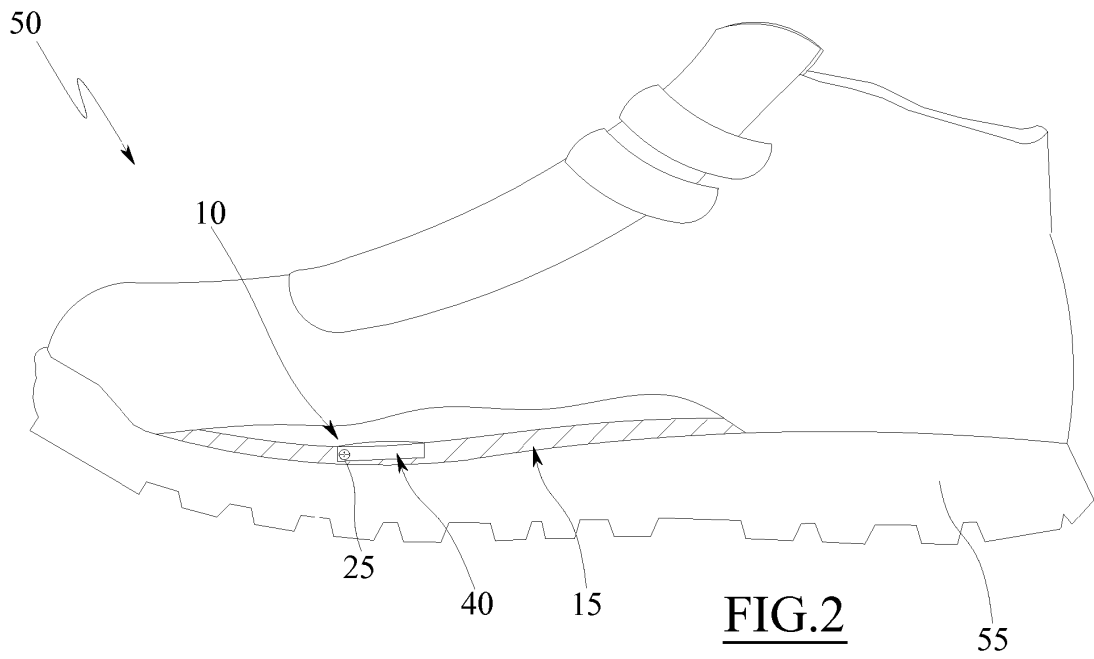
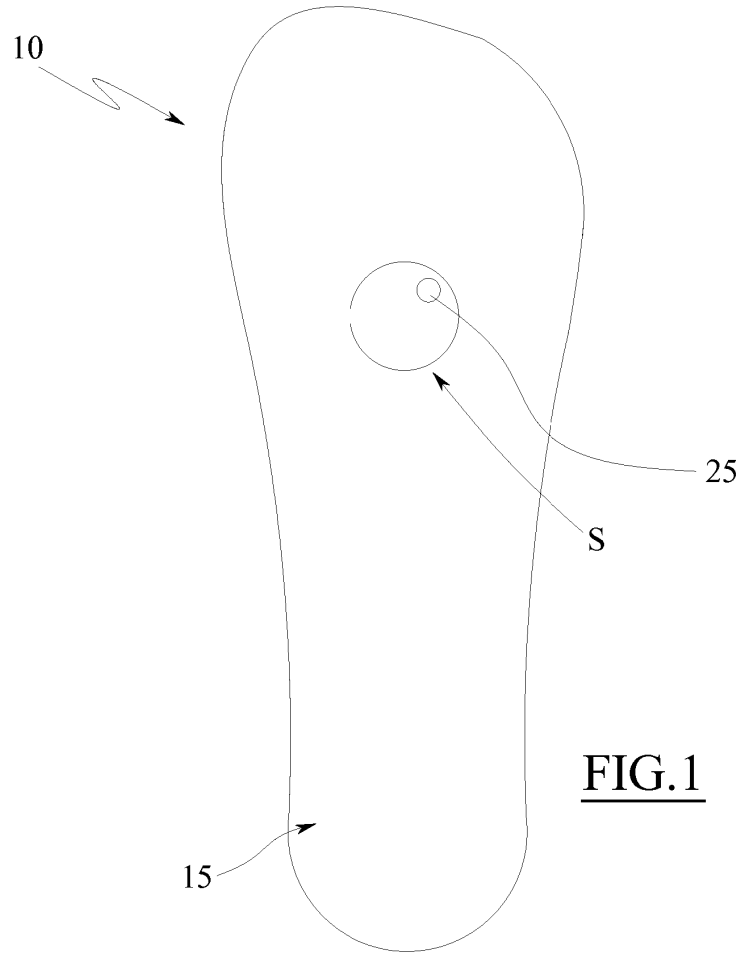

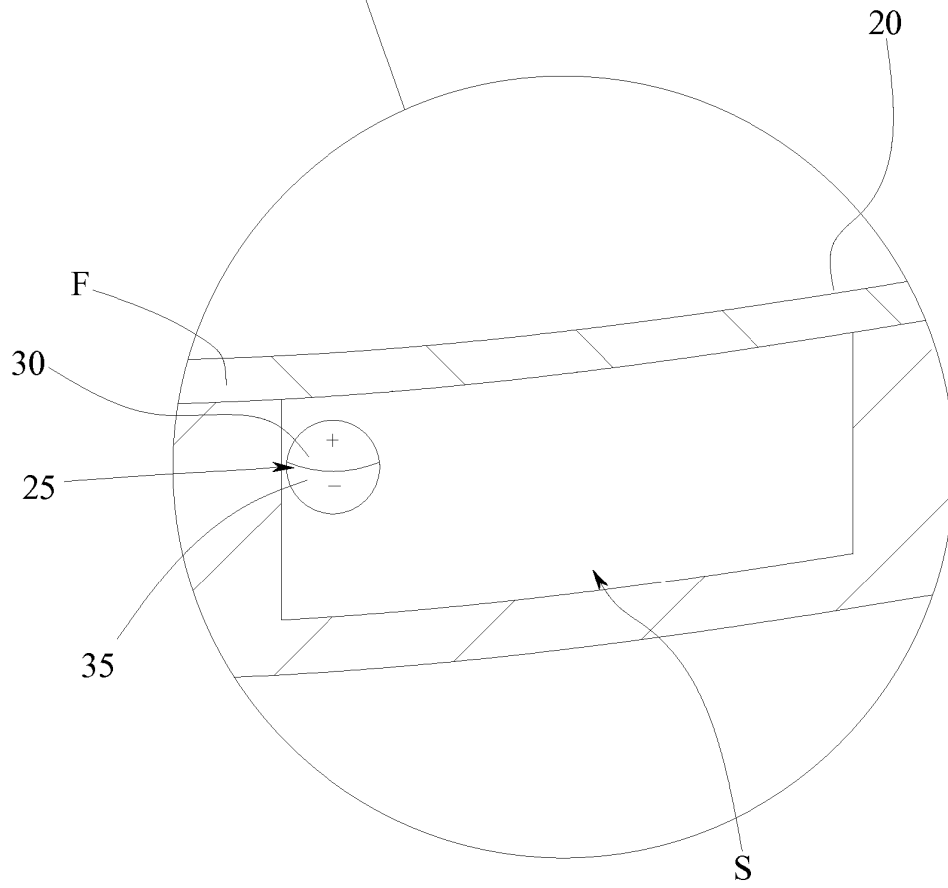
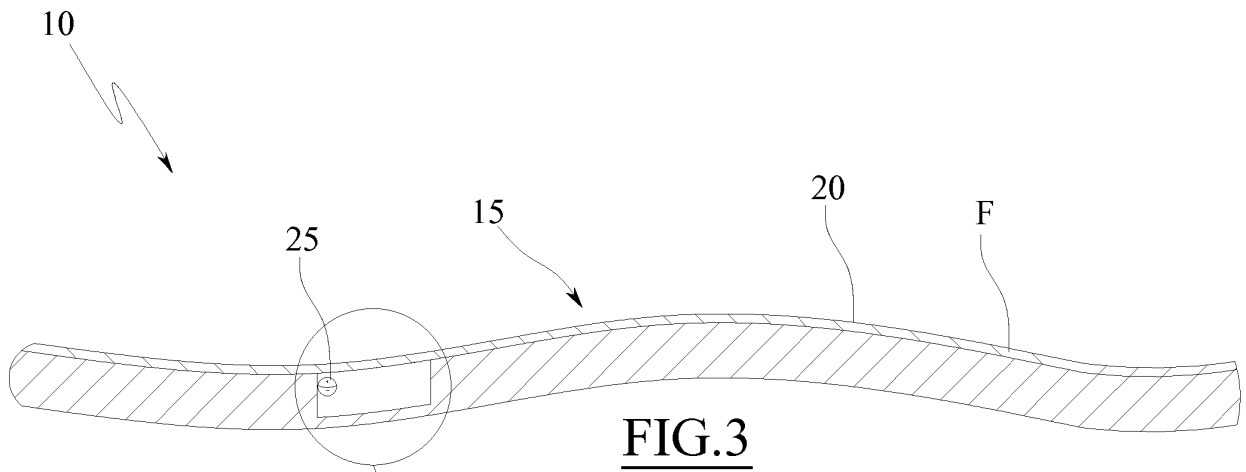

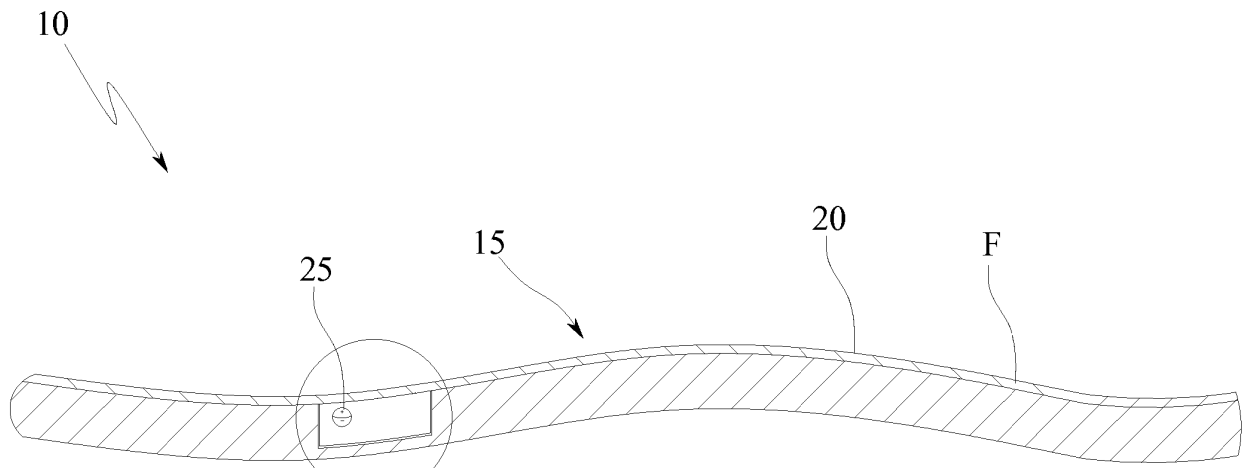

FIG. 5

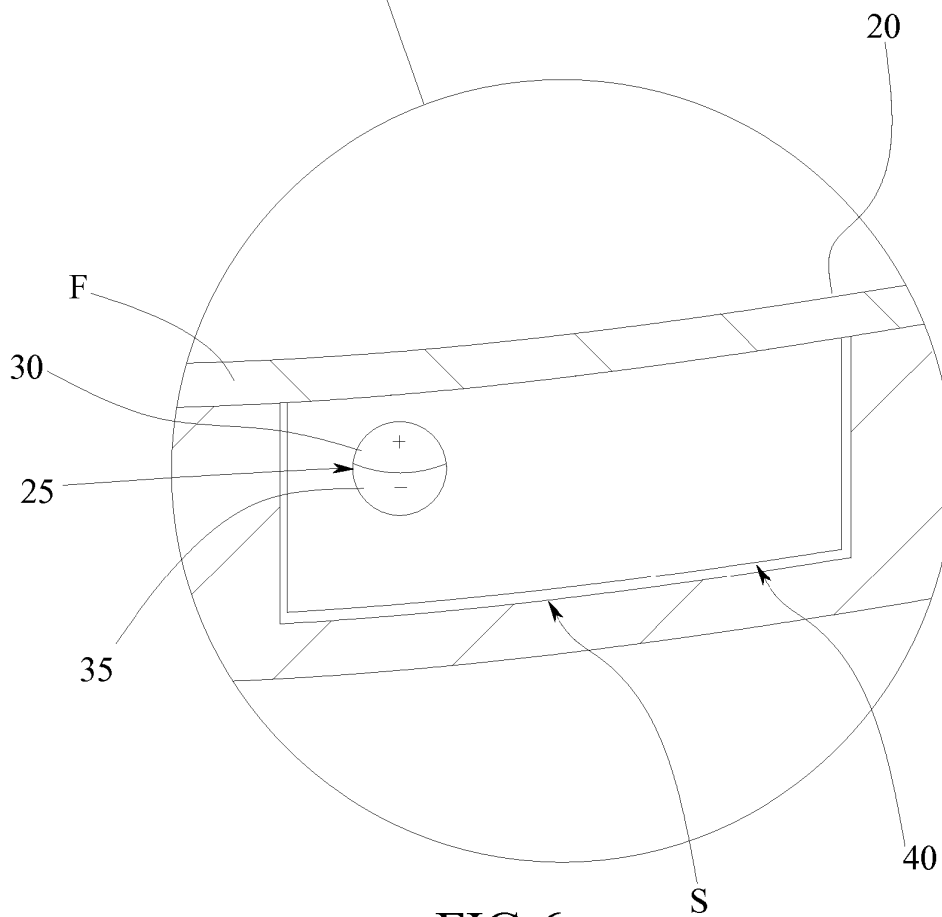

FIG. 6

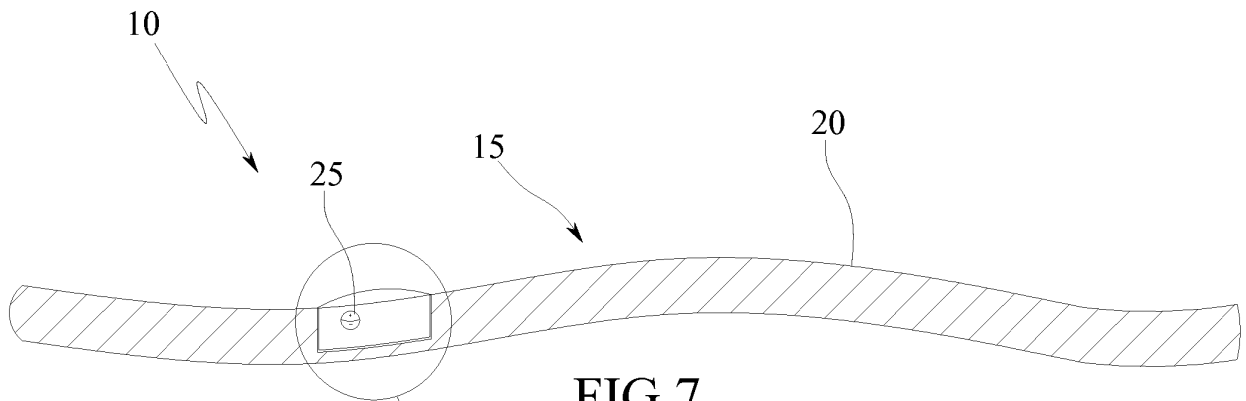

FIG. 7

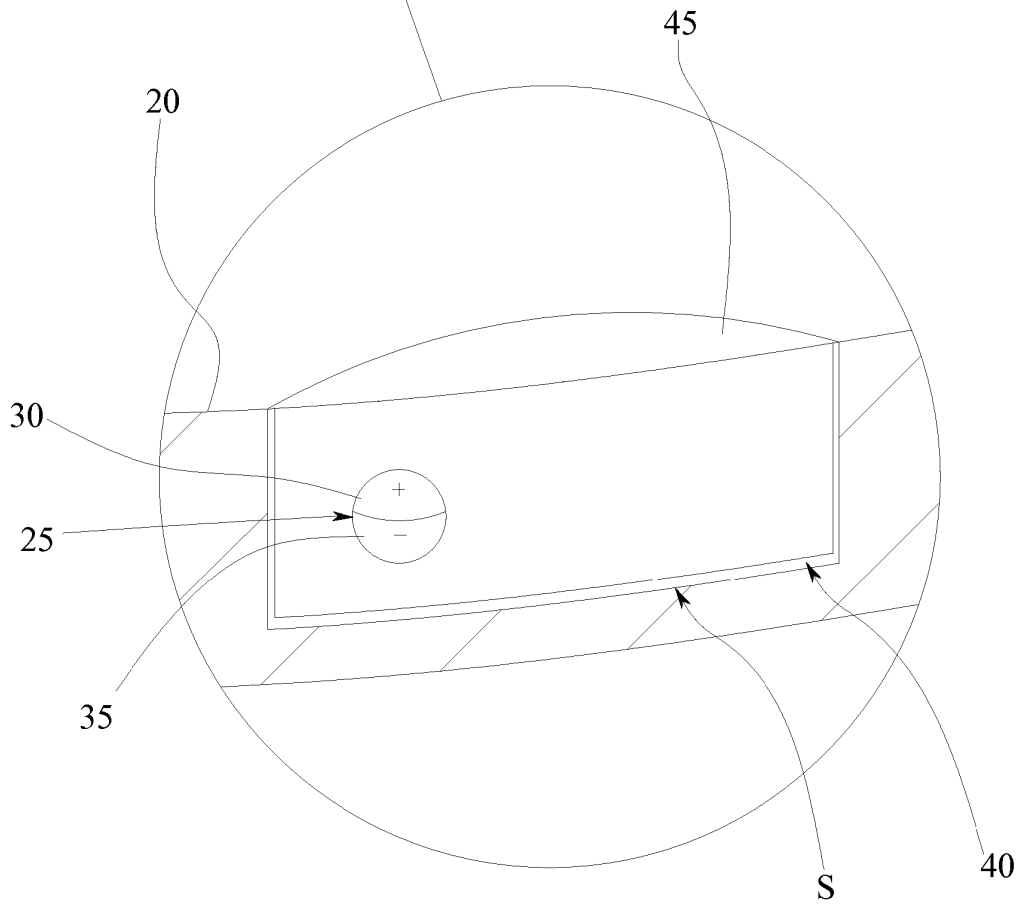

FIG. 8

REFERENCES CITED IN THE DESCRIPTION

This list of references cited by the applicant is for the reader's convenience only. It does not form part of the European patent document. Even though great care has been taken in compiling the references, errors or omissions cannot be excluded and the EPO disclaims all liability in this regard.

Patent documents cited in the description

- US 2012304500 A [0020]