



- (51) International Patent Classification:
B67B 7/04 (2006.01)
- (21) International Application Number:
PCT/GB2013/000158
- (22) International Filing Date:
8 April 2013 (08.04.2013)
- (25) Filing Language: English
- (26) Publication Language: English
- (30) Priority Data:
1206340.0 11 April 2012 (11.04.2012) GB
- (72) Inventor; and
(71) Applicant : BOMMER, Alexander Philip [GB/GB]; 131
Coronation Rd. Shouthville, Bristol, BS3 1RE (GB).

- (81) Designated States (unless otherwise indicated, for every kind of national protection available): AE, AG, AL, AM, AO, AT, AU, AZ, BA, BB, BG, BH, BN, BR, BW, BY, BZ, CA, CH, CL, CN, CO, CR, CU, CZ, DE, DK, DM, DO, DZ, EC, EE, EG, ES, FI, GB, GD, GE, GH, GM, GT, HN, HR, HU, ID, IL, IN, IS, JP, KE, KG, KM, KN, KP, KR, KZ, LA, LC, LK, LR, LS, LT, LU, LY, MA, MD, ME, MG, MK, MN, MW, MX, MY, MZ, NA, NG, NI, NO, NZ, OM, PA, PE, PG, PH, PL, PT, QA, RO, RS, RU, RW, SC, SD, SE, SG, SK, SL, SM, ST, SV, SY, TH, TJ, TM, TN, TR, TT, TZ, UA, UG, US, UZ, VC, VN, ZA, ZM, ZW.
- (84) Designated States (unless otherwise indicated, for every kind of regional protection available): ARIPO (BW, GH, GM, KE, LR, LS, MW, MZ, NA, RW, SD, SL, SZ, TZ, UG, ZM, ZW), Eurasian (AM, AZ, BY, KG, KZ, RU, TJ,

[Continued on next page]

(54) Title: CORKSCREW

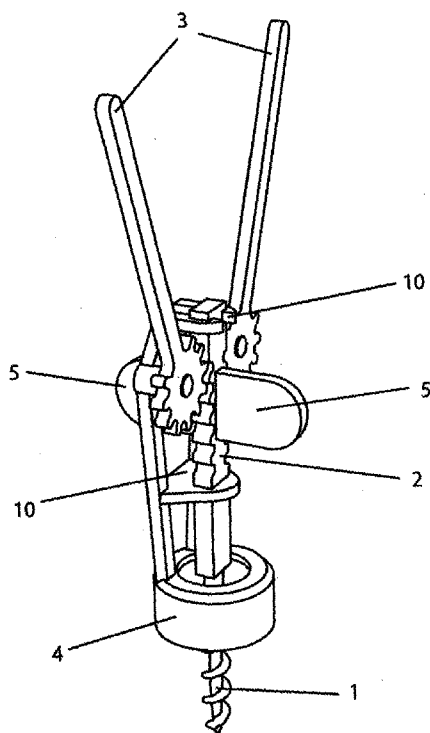

Figure 2

(57) Abstract: A lever type corkscrew with non rotating rack (2) with associated screw detail (1) which is rotatable with the whole assembly. One or more levers (3) are provided which may be offset from the a central axis of the screw detail (1). The screw detail (1) may be weighted or sprung or otherwise biased into its lowest possible position.



TM), European (AL, AT, BE, BG, CH, CY, CZ, DE, DK, EE, ES, FI, FR, GB, GR, HR, HU, IE, IS, IT, LT, LU, LV, MC, MK, MT, NL, NO, PL, PT, RO, RS, SE, SI, SK, SM, TR), OAPI (BF, BJ, CF, CG, CI, CM, GA, GN, GQ, GW, ML, MR, NE, SN, TD, TG). **Published:** — *with international search report (Art. 21(3))*

CORKSCREW

BACKGROUND:

[0001] This invention relates to a lever type corkscrew assembly with an increased level of travel in the levers.

[0002] The travel in the levers of a conventional lever type corkscrew is limited by other parts of the corkscrew getting in the way of the levers at both extremes of their travel. If the lever travel is limited then the mechanical advantage is limited and more effort is required by the user to remove a cork from a bottle. Furthermore, the users knuckles can clash with the levers as they rotate the handle that drives in the screw detail into the cork. Additionally, the restriction in travel can restrict the freedom of designers wishing to customise the appearance of the cork screw assembly as a whole.

STATEMENT OF INVENTION

[0003] To overcome this, the present invention in a general form proposes that the rotating linear rack of gear formations in conventional devices be replaced by a non-rotating rack of linear gear formations and the conventional rotational handle on top of the rotating linear rack of gear formations be replaced by a pair of rotational handles either side of the non-rotating linear rack of gear teeth, or by facilitating rotation of the screw element via rotation of the assembly as a whole, hence allowing more room for the levers to move when in their uppermost position.

[0004] According to the invention there is provided a lever type cork screw assembly including:

- a frame having a lower portion adapted to bear against a bottle neck portion adjacent a cork and an upper portion for rotably supporting one or more levers,

- at least one lever rotably connected about a pivot to said upper portion of the frame, the lever having at its connection end a plurality of gear formations radially disposed around said pivot; and

- a linear non-rotating rack formation from which depends a screw element for engaging a cork;

- the linear rack formation being disposed in interacting engagement with the gear formation on the connection end of the lever;

- 2 -

the linear rack being constrained rotationally by guiding elements on the frame but free to move axially in a direction parallel to or coincident with the centre line of the screw element;

whereby upon rotation of the assembly the screw is driven into a cork thereby causing the rack to move toward the lower portion of the frame in turn causing the lever or levers swing into an upward position, such that subsequent rotation of the lever or levers downwardly in turn moves the rack upwardly thereby extracting the cork.

[0005] Preferably, two levers are provided, ideally on opposing sides of the linear rack formation.

[0006] In various preferred form the assembly includes handle means rigidly connected with the rack formation.

[0007] In one embodiment the screw element is axially aligned with the rack formation. In other embodiments the rack formation is offset from the axis of the screw element thereby providing additional clearance in which the lever or levers can operate.

ADVANTAGES

[0008] The reduction in clashes between the levers and the other part of the lever type corkscrew increases the lever travel hence increasing the mechanical advantage. This either reduces the force the user requires to remove a cork or allows the cork to be pulled further out of the bottle. Clashes between the user's knuckles and the levers of the corkscrew are also reduced. Additionally, the restriction in travel can restrict the freedom of designers wishing to customise the appearance of the cork screw assembly as a whole.

[0009] Furthermore, in embodiments with levers offset from the centre line of the screw detail itself, it eliminates clashes in the down position of the levers.

[0010] Further, in embodiments with the component carrying the screw detail being weighted or sprung loaded in the down position, it ensures that the cork on the end of the screw detail is presented outside the frame of the corkscrew making it readily accessible for the user to remove from the screw detail once it has been pulled from the bottle.

INTRODUCTION TO DRAWINGS

[0011] Preferred examples of the invention will now be described by referring to the accompanying drawings:

[0012] Figure 1. Shows a traditional lever type corkscrew in three positions as it pulls a cork from a bottle showing clashes at both extremes of travel of the levers.

[0013] Figure 2. shows a lever type corkscrew where the rotating linear rack of gear formations and rotational handle above it, have been replaced by a non rotating linear rack of gear teeth and rotational handles either side of the linear rack according to the invention.

[0014] Figure 3. Shows a design similar to Fig 2 where the linear rack of gear formations has been offset from the centre line of the screw detail.

[0015] Figure 4. shows a design identical to figure 2 but with a spring to ensure the cork is presented outside the frame for ease of removal

[0016] Figure 5. Shows a design similar to figure 4 where the spring has been replaced by a weight to perform the same function.

DETAILED DESCRIPTION

[0017] A conventional corkscrew, such as that shown in Figures 1a-1c, is structured as follows.

[0018] A pair of levers 3 with a plurality of gear formations radially disposed around a pivot at one end are rotably connected to the frame 4 with the gear formations engaged with a linear rotating rack formation 2. A screw element 1 has a centre line which is parallel and in line with the linear rotating rack formation 2 is connected rigidly to the linear rack 2. A handle detail 5 is attached directly above and in line with the linear rack 2. The linear rack 2 is rotationally symmetrical about the centre line of the screw element 1. The linear rack 2 which is held by guides 10 on the frame 4 is free to move rotationally and axially about the centre line of the screw element 1. As the handle detail 5 is rotated it rotates the attached linear rack 2 and screw element 1 hence driving the screw element 1 into the cork 6. As the screw element 1 drives into the cork 6 it pulls the linear rack 2 down relative to the frame 4 which is fixed relative to the bottle 9 which is static relative to the cork 6. The movement of

the linear rack 2 downwards relative to the frame 4 in turn causes the levers 3 to swing into an upward position, such that subsequent rotation of the levers 3 downwardly moves the rack 2 upwardly thereby extracting the cork 6. It can be seen from figure 1a that the travel of the levers 3 is limited by the handle detail 5 in the up position while Figure 1c shows how the travel of the levers 3 is limited in the down position by the frame 4. Since the travel of the levers 3 is limited the mechanical advantage is limited and hence the effort required by the user to remove the cork is increased. The user's knuckles can also clash with the levers 3 when in their upper most position as they operate the handle detail 5.

[0019] Referring to Figure 2 there is shown a first embodiment corkscrew of the invention. In all cases like reference numerals will be used to denote corresponding features.

[0020] In this first embodiment a pair of levers 3 with a plurality of gear formations radially disposed around a pivot at one end are rotably connected to the frame 4 with the gear formations engaged with a linear non rotating rack formation 2.

[0021] A screw detail 1 has a centre line which is parallel and in line with the linear rack 2 is connected rigidly to the linear non rotational rack 2. A handle detail 5 is attached rigidly to either side horizontally of the linear rack formation 2. The linear rack formation 2 being constrained rotationally by guiding elements 10 on the frame 4 but free to move axially in the same direction as the centre line of the screw element 1;

[0022] As a frame 4 is placed on to a bottle, the screw detail 1, the linear rack 2 and attached horizontal handle details 5 are pushed in an upwards direction by the cork 6 as it moves upwards relative to the frame 4. Simultaneously the relative motion of the linear rack 2 relative to the frame 4 drives the pair of levers 3 in a downwards direction relative to the frame 4. At this point the horizontal handle details 5 are assessable to the user allowing them to apply a torsional load and hence drive the screw detail 1 into the cork. As the screw detail 1 twists into the cork 6 it pulls down the linear rack of gear teeth 2 relative to frame 4 which remains fixed relative to the cork 6. As the linear rack 2 moves downwards relative to the frame 4 the levers 3 are driven upwards relative to the frame 4. The levers 3 operate in a plane which is not penetrated or obstructed by the means by which the screw detail 1 and rack 2 operate. At some point the levers 3 are in a position sufficiently close to the height of their pivots, that they are readily accessible to the user and can also be used to apply a torsional load to the screw detail 1 via the frame 4. Once the levers 3 are in their uppermost position relative to the frame 4 with the screw detail embedded in the cork, the levers 3 are

pushed down relative to the frame 4 which drives the linear rack of gear teeth 2 and screw detail 1 up relative the frame 4, which in turn pulls the cork from the bottle. The screw element 1 can be twisted into the cork 6 by the user applying a torsional load to any part of the corkscrew assembly including, but not restricted to, the frame 4, levers 3, linear rack 2 and or the handle details 5.

[0023] Turning next to Figure 3 there is shown a second embodiment of the invention.

[0024] This second embodiment is very similar to the first except that the levers 3 and linear rack formation 2 are offset from the centre line of the screw element 1. Therefore the levers 3 are able to move further in their lowest position as their path is not blocked by the frame 4.

[0025] Turning next to Figure 4 there is shown a third embodiment of the invention.

[0026] This third embodiment is the same as the first embodiment with the addition of a spring 7 to drive down the screw element 1 to ensure the cork 6 is outside of the frame 4 to make it assessable for removal from the screw element 1. The spring 7 could also be applied to the second embodiment.

[0027] Turning next to Figure 5 there is shown a fourth embodiment of the invention.

[0028] This fourth embodiment is the same as the third embodiment with the spring replaced by a counter weight 8 to achieve the same purpose. The counter weight 8 could also be applied to the second embodiment.

[0029] It will be appreciated that the reduction in clashes between the levers and the other part of the lever type corkscrew of the invention increases the lever travel hence potentially increasing the mechanical advantage. This can be exploited to either reduce the force the user requires to remove a cork or enable the cork to be pulled further out of the bottle. Clashes between the user's knuckles and the levers of the corkscrew may also be reduced. Furthermore, in embodiments with levers offset from the centre line of the screw detail itself, it eliminates clashes in the down position of the levers.

[0030] Additionally, in embodiments with the component carrying the screw detail being weighted or sprung loaded in the down position, this ensures that the cork on the end of the

screw detail is presented outside the frame of the corkscrew making it accessible for the user to remove from the screw detail once it has been pulled from the bottle.

[0031] In further embodiments, the corkscrew may also include a bearing detail attached to the lower part of the frame and located between the bottle and the frame to aid the smooth rotation of the corkscrew assembly relative to the static bottle as the screw detail is inserted into the cork.

[0032] The corkscrew device may also include friction damping of the lever or levers rotation to reduce any rattle or vibration of the lever and ensure smooth operation. This can be achieved by any suitable means including the use of an additional flexible part fixed to the top of frame near to the pivot point to the rotatable levers and in intimate contact with the lever in order to provide frictional resistance to the rotation of the lever or levers.

[0033] Further modifications may include the use of , a spike detail on the end of the screw detail to help with locating the corkscrew assembly into the cork.

[0034] While the invention has been described with reference to specific embodiments and variations, it will be appreciated by those skilled in the art that the concepts of the invention can be embodied in many other forms. For example the assembly could use a single lever rather than two, and/or have the levers located such as to not be directly opposed.

[0035] Further, the new structure with improved travel, flexibility in structure and/or improved operation also better facilitates customisation of the appearance of the device if desired.

CLAIMS

1. A lever type cork screw assembly including:
 - a frame having a lower portion adapted to bear against a bottle neck portion adjacent a cork and an upper portion for rotably supporting one or more levers,
 - at least one lever rotably connected about a pivot to said upper portion of the frame, the lever having at its connection end a plurality of gear formations radially disposed around said pivot; and
 - a linear non rotating rack formation from which depends a screw element for engaging a cork;
 - the linear rack formation being disposed in interacting engagement with the gear formation on the connection end of the lever;
 - the linear rack being constrained rotationally by guiding elements on the frame but free to move axially in a direction parallel to or coincident with the centre line of the screw element;
 - whereby upon rotation of the assembly the screw is driven into a cork thereby causing the rack to move toward the lower portion of the frame in turn causing the lever or levers swing into an upward position, such that subsequent rotation of the lever or levers downwardly in turn moves the rack upwardly thereby extracting the cork.
2. A lever type cork screw according to claim 1 including two levers disposed on separate operational sides of the linear rack.
3. A lever type cork screw according to claim 2 wherein two levers are provided on opposing operational sides of the linear rack.
4. A lever type cork screw according to any one of the preceding claims including handle means connected with the linear rack to effect rotation thereof with the assembly.
5. A lever type cork screw according to any one of the preceding claims wherein an axis of the linear rack is generally aligned with a central axis of the screw element.
6. A lever type cork screw according to any one of claims 1 to claim 4 wherein the lever or levers and rack are offset from a central axis of the screw element.
7. A lever type corkscrew according to any one of the preceding claims including means to bias the screw detail into a position outside of the frame.

8. A lever type corkscrew according to claims 6 wherein the biasing means is a spring.
9. A lever type corkscrew according to claim 8 wherein the spring is secured between the frame and a fixing point provided on the structure that includes the rack formation.
10. A lever type corkscrew according to claim 6 wherein the biasing means is a weight.
11. A lever type corkscrew according to claim 10 wherein the weight is secured to a fixing point provided on the structure that includes the rack formation.
12. A lever type corkscrew according to claim 9 or claim 11 wherein the assembly includes handle means to effect rotation of the rack and assembly and the fixing point is located on the handle means.
13. A lever type corkscrew according to claims 1 to 6 wherein the rotation of the levers are friction damped to reduce any rattle or vibration.
14. A lever type corkscrew according to any of the claims above wherein the assembly includes a bearing detail on the lower part of the frame between the frame and the bottle to reduce friction between the bottle and frame when the corkscrew assembly is rotated.

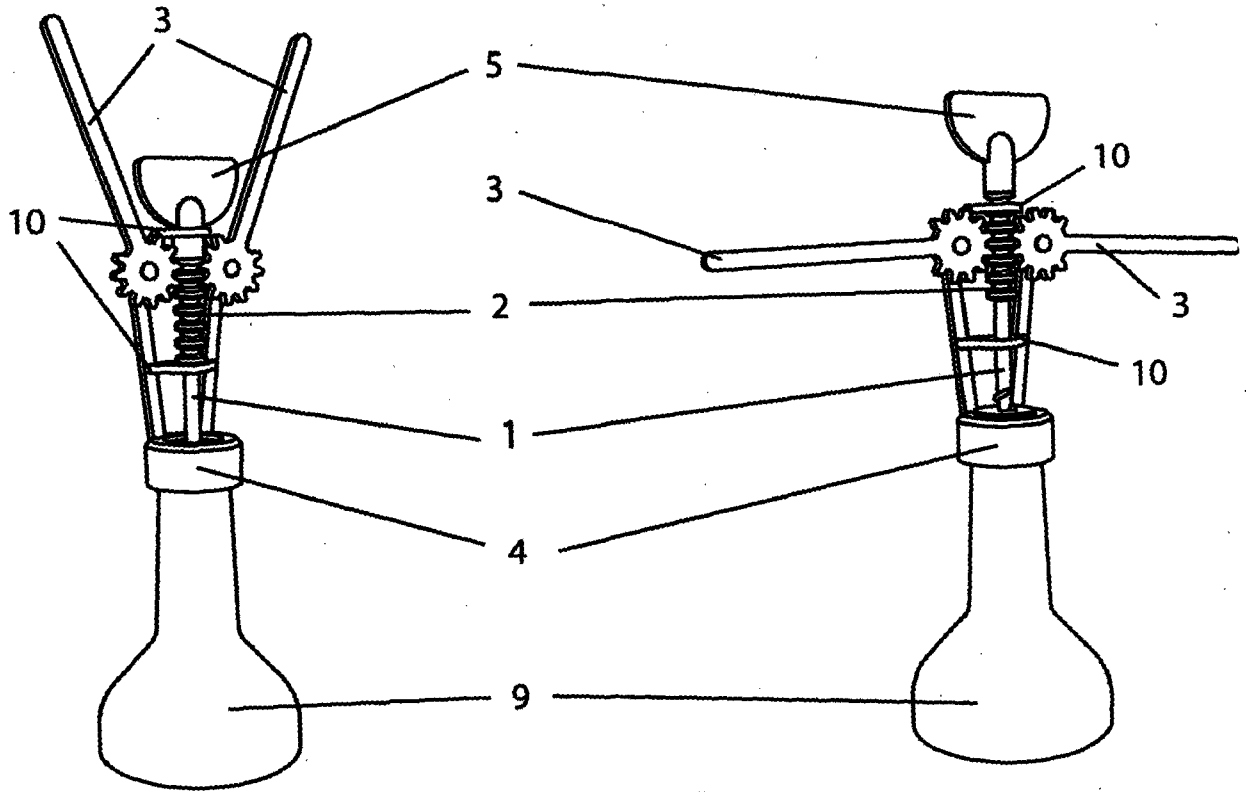

Figure 1a

Figure 1b

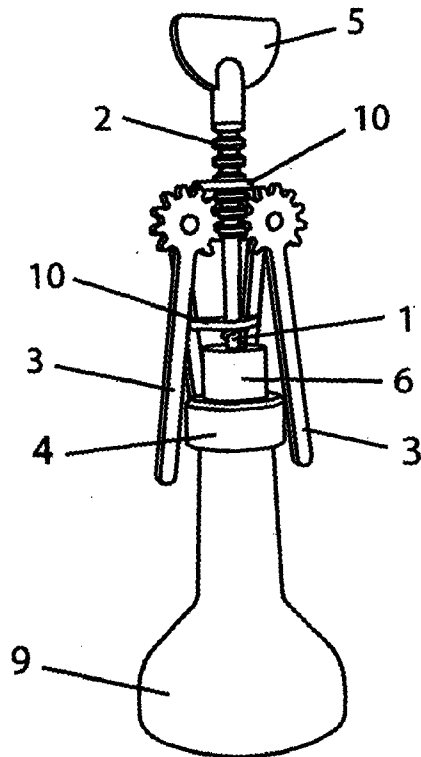

Figure 1c

Figure 1

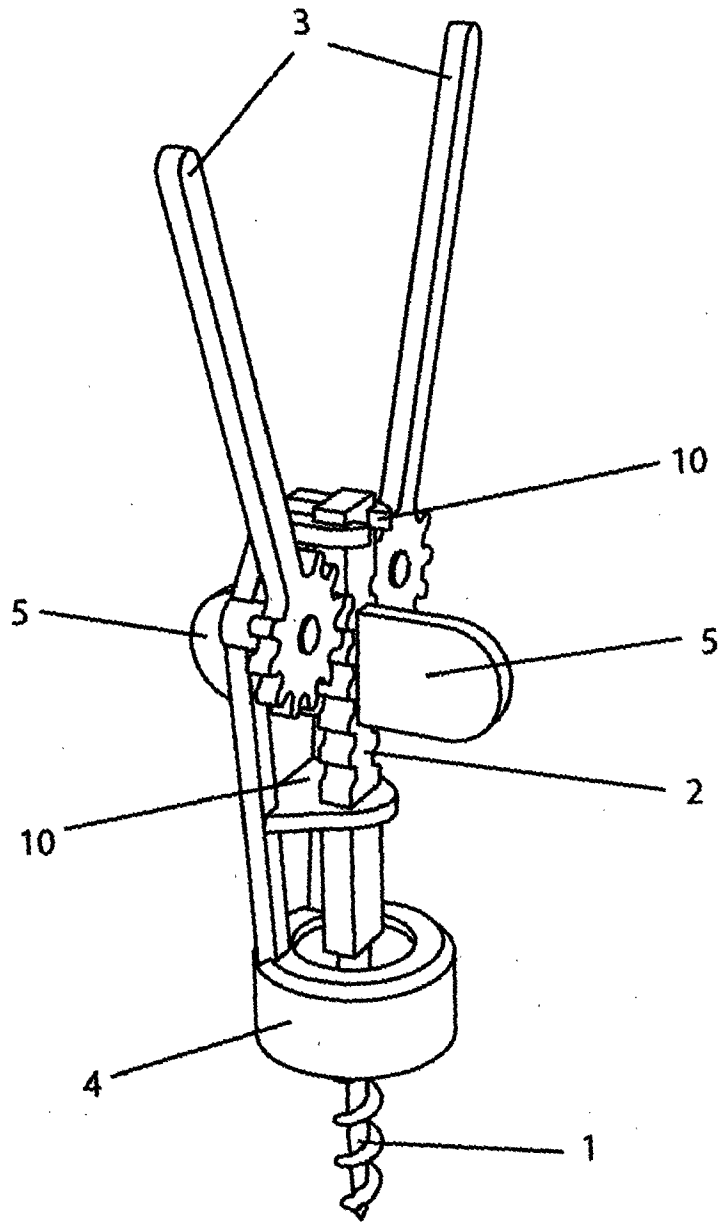

Figure 2

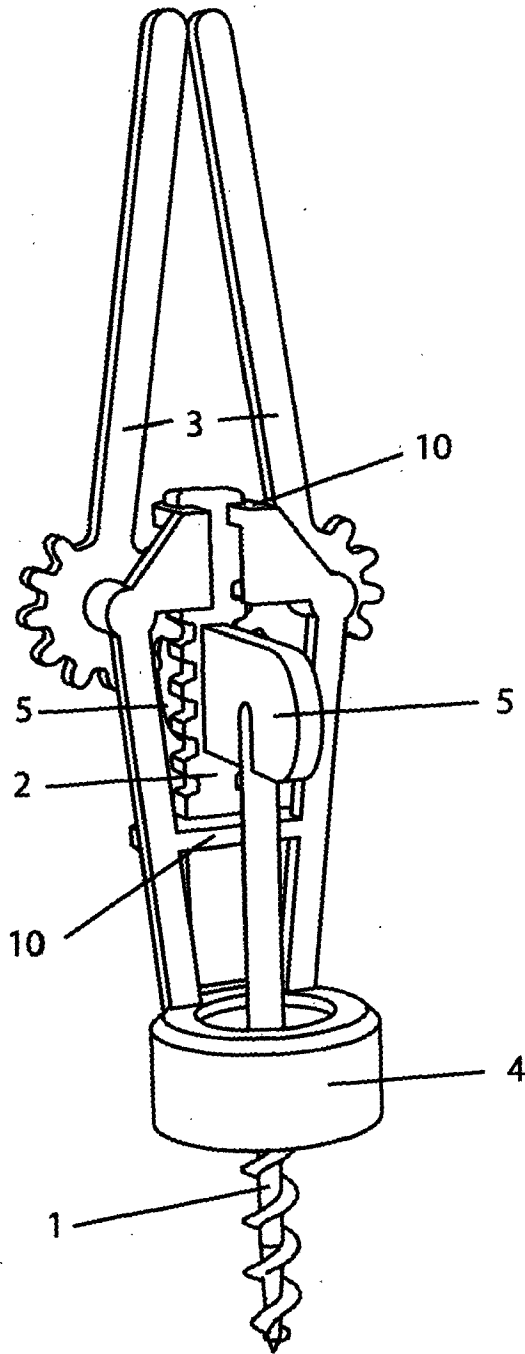

Figure 3

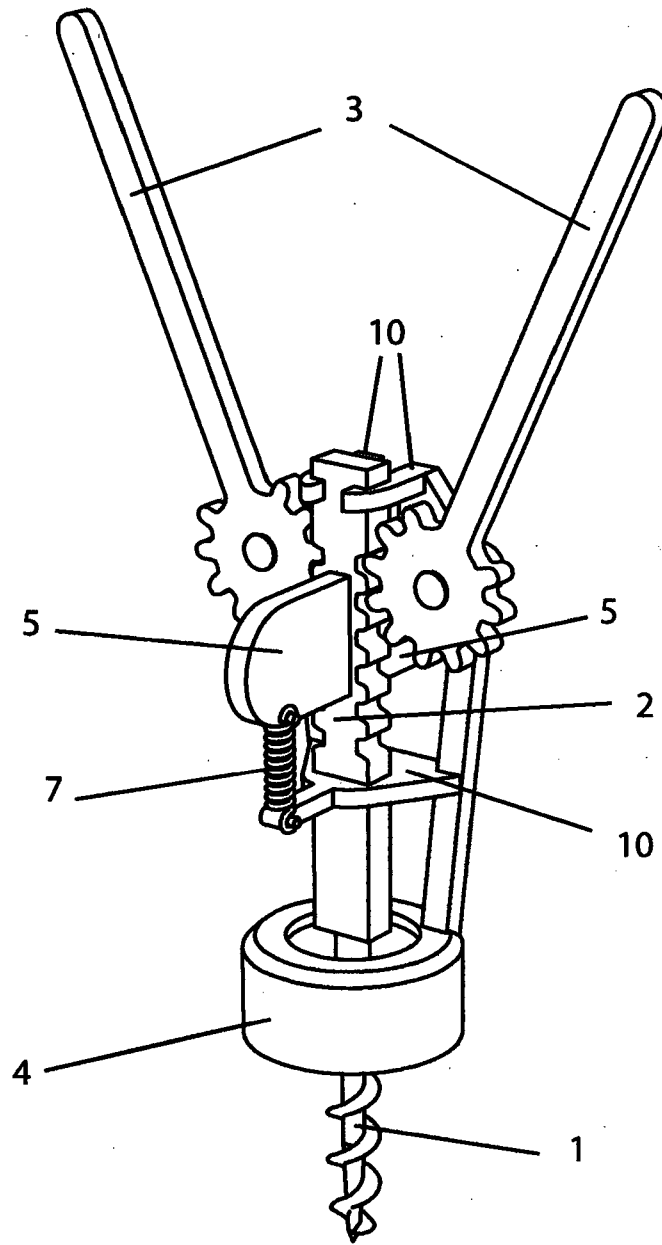

Figure 4

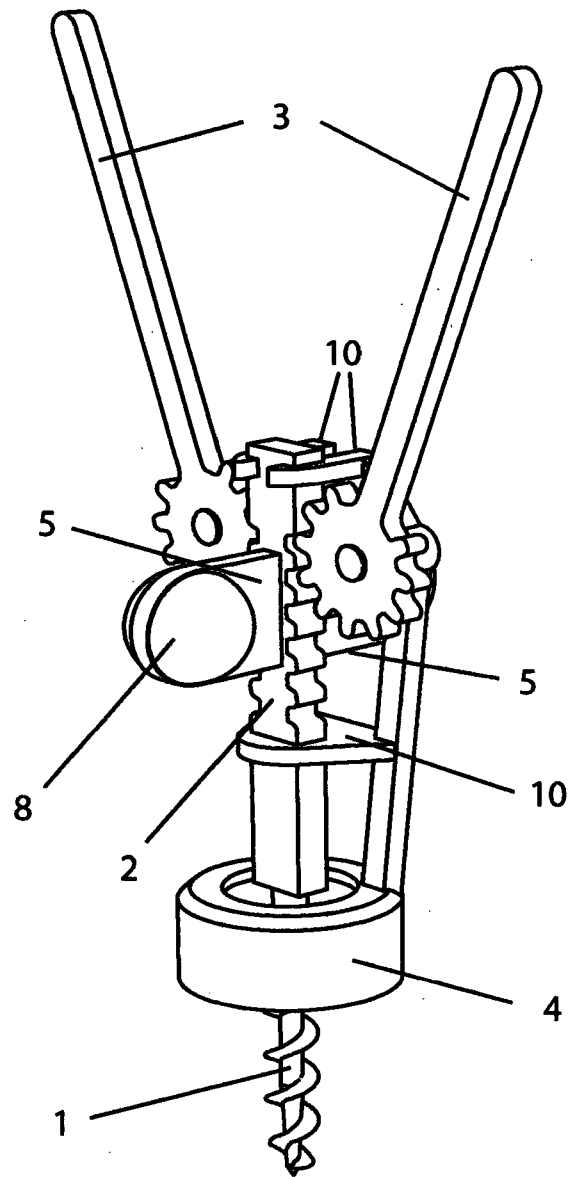

Figure 5

INTERNATIONAL SEARCH REPORT

International application No
PCT/GB2013/000158

A. CLASSIFICATION OF SUBJECT MATTER
INV. B67B7/04
ADD.

According to International Patent Classification (IPC) or to both national classification and IPC

B. FIELDS SEARCHED
Minimum documentation searched (classification system followed by classification symbols)
B67B

Documentation searched other than minimum documentation to the extent that such documents are included in the fields searched

Electronic data base consulted during the international search (name of data base and, where practicable, search terms used)
EPO-Internal, WPI Data

C. DOCUMENTS CONSIDERED TO BE RELEVANT

Category*	Citation of document, with indication, where appropriate, of the relevant passages	Relevant to claim No.
X	FR 2 359 785 A1 (ARTLEVA TOMASONI GIACOMO MARIO [IT]) 24 February 1978 (1978-02-24) figures 1-4 page 3, line 6 - page 5, line 1 -----	1-5, 7-11,13, 14
X	BE 484 196 A (GRANDFILS) 31 August 1948 (1948-08-31) figures 1-4 page 2, line 6 - page 3, line 17 -----	1,4,6-14
X	FR 668 812 A (BUSSIÈRE, PIERRE [FR]) 7 November 1929 (1929-11-07) figures 1,2 page 1, lines 19-57 ----- -/--	1,4, 6-11,13, 14

Further documents are listed in the continuation of Box C.

See patent family annex.

* Special categories of cited documents :

<p>"A" document defining the general state of the art which is not considered to be of particular relevance</p> <p>"E" earlier application or patent but published on or after the international filing date</p> <p>"L" document which may throw doubts on priority claim(s) or which is cited to establish the publication date of another citation or other special reason (as specified)</p> <p>"O" document referring to an oral disclosure, use, exhibition or other means</p> <p>"P" document published prior to the international filing date but later than the priority date claimed</p>	<p>"T" later document published after the international filing date or priority date and not in conflict with the application but cited to understand the principle or theory underlying the invention</p> <p>"X" document of particular relevance; the claimed invention cannot be considered novel or cannot be considered to involve an inventive step when the document is taken alone</p> <p>"Y" document of particular relevance; the claimed invention cannot be considered to involve an inventive step when the document is combined with one or more other such documents, such combination being obvious to a person skilled in the art</p> <p>"&" document member of the same patent family</p>
---	---

Date of the actual completion of the international search 14 August 2013	Date of mailing of the international search report 22/08/2013
---	--

Name and mailing address of the ISA/ European Patent Office, P.B. 5818 Patentlaan 2 NL - 2280 HV Rijswijk Tel. (+31-70) 340-2040, Fax: (+31-70) 340-3016	Authorized officer Pardo, Ignacio
--	--

INTERNATIONAL SEARCH REPORT

International application No

PCT/GB2013/000158

C(Continuation). DOCUMENTS CONSIDERED TO BE RELEVANT		
Category*	Citation of document, with indication, where appropriate, of the relevant passages	Relevant to claim No.
X	NL 1 024 761 C2 (VACU VIN INNOVATIONS LTD [GI]) 12 May 2005 (2005-05-12) figures 1-7 page 4, line 10 - page 7, line 5 -----	1,4,5,7, 10,13,14
X	DE 130 844 C (RIOLET, FÉLIX [CH]) 10 April 1901 (1901-04-10) the whole document -----	1,2,4,5, 7,8,10, 11,13,14
X	US 2007/079669 A1 (WROBEL DAVID J [US] ET AL) 12 April 2007 (2007-04-12) figures 1-4 paragraphs [0018] - [0028] -----	1,5, 7-11,13, 14
A	FR 2 103 715 A5 (FORTUNATO WALTER) 14 April 1972 (1972-04-14) figure 1 page 2, lines 21-30 -----	8,9
A	US 5 934 160 A (GIBSON JEREMY H [US]) 10 August 1999 (1999-08-10) figures 1-10 column 6, line 60 - column 7, line 26 column 8, lines 10-19 -----	13,14

INTERNATIONAL SEARCH REPORT

Information on patent family members

International application No

PCT/GB2013/000158

Patent document cited in search report	Publication date	Patent family member(s)	Publication date
FR 2359785	A1	24-02-1978	
		BE 857207 A1	14-11-1977
		DE 2732920 A1	02-02-1978
		FR 2359785 A1	24-02-1978
		IT 1065956 B	04-03-1985

BE 484196	A	31-08-1948	NONE

FR 668812	A	07-11-1929	NONE

NL 1024761	C2	12-05-2005	NONE

DE 130844	C	10-04-1901	NONE

US 2007079669	A1	12-04-2007	NONE

FR 2103715	A5	14-04-1972	
		BE 812449 A7	15-07-1974
		FR 2103715 A5	14-04-1972

US 5934160	A	10-08-1999	NONE
