



INTERNATIONAL APPLICATION PUBLISHED UNDER THE PATENT COOPERATION TREATY (PCT)

<p>(51) International Patent Classification ⁶ : A61F 2/44</p>	<p>A1</p>	<p>(11) International Publication Number: WO 95/15133 (43) International Publication Date: 8 June 1995 (08.06.95)</p>
<p>(21) International Application Number: PCT/US94/13709 (22) International Filing Date: 2 December 1994 (02.12.94) (30) Priority Data: 08/163,051 3 December 1993 (03.12.93) US (71) Applicant: CALCITEK, INC. [US/US]; 2320 Faraday Avenue, Carlsbad, CA 92008 (US). (72) Inventors: WAGNER, William, R.; 1225 Via Ramon, Escondido, CA 92029 (US). SLABBEKOORN, Scott, D.; 5220 Logan Avenue South, Minneapolis, MN 55419 (US). (74) Agents: GARMONG, Gregory, O.; P.O. Box 12460, Zephyr Cove, NV 89448 (US) et al.</p>		<p>(81) Designated States: JP, European patent (AT, BE, CH, DE, DK, ES, FR, GB, GR, IE, IT, LU, MC, NL, PT, SE). Published <i>With international search report.</i></p>

(54) Title: SPINAL DISK IMPLANT AND KIT

(57) Abstract

A spinal disk implant (50) comprises a solid body having four faces (64, 66, 68, 70) arranged to define a right-rectangular solid body and two faces (52, 54) that define the ends of the solid body. The faces that define the right-rectangular body include two opposed side faces (64, 66) and two opposed transverse faces (68, 70). A kit that may be used by a surgeon includes an implant (50) and an implant delivery tool (100) dimensioned to releasably hold the implant (50). The delivery tool (100) preferably has an implant holder with a pair of flexible opposed arms (102)

extending from a base (101), separated so that the implant (50) can fit between the arms (102). Optionally, the implant holder may have a breakable release band (104) extending around the implant (50) to hold it in place until a weak link (108) in the release band (104) is intentionally broken during implantation.

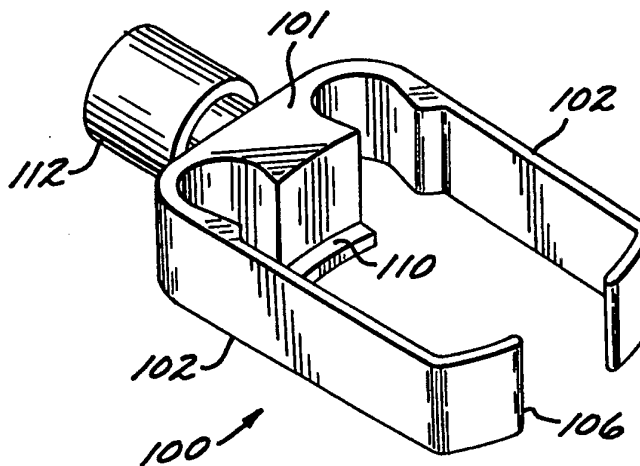

FOR THE PURPOSES OF INFORMATION ONLY

Codes used to identify States party to the PCT on the front pages of pamphlets publishing international applications under the PCT.

AT	Austria	GB	United Kingdom	MR	Mauritania
AU	Australia	GE	Georgia	MW	Malawi
BB	Barbados	GN	Guinea	NE	Niger
BE	Belgium	GR	Greece	NL	Netherlands
BF	Burkina Faso	HU	Hungary	NO	Norway
BG	Bulgaria	IE	Ireland	NZ	New Zealand
BJ	Benin	IT	Italy	PL	Poland
BR	Brazil	JP	Japan	PT	Portugal
BY	Belarus	KE	Kenya	RO	Romania
CA	Canada	KG	Kyrgystan	RU	Russian Federation
CF	Central African Republic	KP	Democratic People's Republic of Korea	SD	Sudan
CG	Congo	KR	Republic of Korea	SE	Sweden
CH	Switzerland	KZ	Kazakhstan	SI	Slovenia
CI	Côte d'Ivoire	LI	Liechtenstein	SK	Slovakia
CM	Cameroon	LK	Sri Lanka	SN	Senegal
CN	China	LU	Luxembourg	TD	Chad
CS	Czechoslovakia	LV	Latvia	TG	Togo
CZ	Czech Republic	MC	Monaco	TJ	Tajikistan
DE	Germany	MD	Republic of Moldova	TT	Trinidad and Tobago
DK	Denmark	MG	Madagascar	UA	Ukraine
ES	Spain	ML	Mali	US	United States of America
FI	Finland	MN	Mongolia	UZ	Uzbekistan
FR	France			VN	Viet Nam
GA	Gabon				

-1-

SPINAL DISK IMPLANT AND KIT

BACKGROUND OF THE INVENTION

5 This invention relates to implants surgically placed into the human body and the implant delivery tool used to perform the implantation, and, more particularly, to an implant placed between two vertebrae to fuse them together and its implant delivery tool.

10 The human spine is composed of a column of 33 bones, termed vertebrae, and their joining structures. The 24 vertebrae nearest the head, collectively termed the presacral vertebrae, are separate bones capable of individual movement. The bodies of the presacral vertebrae are generally
15 connected by anterior and posterior longitudinal ligaments and by discs of fibrocartilage, termed intervertebral disks, positioned between opposing faces of adjacent vertebral bodies. These mobile vertebrae may be classified by their position and
20 function into either cervical, thoracic, or lumbar vertebrae. The remaining 9 vertebrae are fused to form the sacrum (5 vertebrae) and the coccyx (4 vertebrae) and are incapable of individual movement.

25 This column of vertebrae and intervertebral disks forms a central axis for supporting the load of the head and torso. The vertebral body and the dorsal vertebral arch of each of the 24 mobile presacral vertebrae enclose an opening, termed the vertebral foramen, through which the spinal cord, a
30 column of nerve tissue which communicates nerve impulses between the brain and the rest of the body, and the spinal nerve roots pass and are protected from damage.

-2-

The presacral vertebrae are normally held in a precise relation to each other by the intervertebral disks, the longitudinal ligaments, and the musculature of the body. These vertebrae
5 can move relative to adjacent vertebrae in various manners, providing a wide range of flexibility to the spine. The movement between individual pairs of vertebrae is limited to prevent local pressure on the spinal cord or excessive bending of the spinal
10 cord. Such pressure or bending could possibly result in disorders associated with blockage of the nerve impulses traveling along the spinal cord, in turn producing pain, paresthesia, or loss of motor control which must be resolved by removing the
15 causative condition.

The nerve conduction disorders may also be associated with the intervertebral disks or the bones themselves. One such condition is a herniation of the intervertebral disk, in which a
20 small amount of tissue protrudes from the sides of the disk into the foramen to compress the spinal cord. A second common condition involves the development of small bone spurs, termed osteophytes, along the posterior surface of the vertebral body,
25 again impinging on the spinal cord. Progressive degeneration of intervertebral disks, commonly accompanied by loss of resiliency or integrity, is frequently a natural consequence of aging.

Upon identification of the abnormality
30 causing the conduction disorders, surgery may be required to correct the problem if more conservative treatment fails. For those problems associated with the formation of osteophytes or herniations of the intervertebral disk, one such surgical procedure is
35 intervertebral discectomy. In this procedure, the involved vertebral bodies are exposed and the

-3-

intervertebral disk is removed, thus removing the offending tissue, or providing access for the removal of the bone osteophytes. A second procedure, termed a spinal fusion, may then be
5 required to fix the vertebral bodies together to prevent movement and maintain the space originally occupied by the intervertebral disk..

During a spinal fusion following a discectomy, an implant is inserted into the
10 intervertebral space. This intervertebral implant is often a bone graft removed from another portion of the patient's body, termed an autograft. The use of bone taken from the patient's body has the important advantage of avoiding rejection of the
15 implant, but has some shortcomings. There is always a risk in opening a second surgical site for obtaining the bone graft, which can lead to increased morbidity for the patient, and the site of the bone graft is weakened by the removal of bony
20 material. The bone implant may not be perfectly shaped and placed, leading to slippage or absorption of the implant, or failure of the implant to fuse with the vertebrae.

Other options for a graft source for the
25 implant are bone removed from other human sources, termed an allograft, or from another species, termed a xenograft. In these cases, while there is the benefit of not having a second surgical site as a possible source of infection or pain, there are the
30 increased risks of graft rejection and communicable disease transmission.

An alternative approach to using a bone graft is to use a manufactured implant made of a synthetic material that is biologically compatible with the
35 body. Several compositions and geometries of such implants have been utilized, ranging from simple

-4-

blocks of material to carefully shaped implants, with varying success. No fully satisfactory implant has been reported. In some instances, the implantation is readily accomplished, but the results are unsatisfactory due to side effects or dislocation of the implant. In other instances, the implant requires a complex surgical procedure that is difficult to perform and still may not lead to correction of the problem for the reasons indicated.

There is therefore a need for an improved spinal disk implant, which is both readily utilized in a surgical procedure and has a high probability of success without undesirable side effects. The present invention fulfills this need, and further provides related advantages.

SUMMARY OF THE INVENTION

The present invention provides a readily manufactured and implanted spinal disk implant. The disk implant is configured to engage the cortical bone region of the vertebrae after implantation, so that the majority of the loading transmitted through the implant is carried by the cortical bone. Since the cortical bone is harder than the cancellous bone region of the vertebrae, it is less likely that the spinal column will post-operatively compress around the implant. The implant also provides structure to improve the engagement between the implant and the adjacent vertebrae, minimizing the likelihood that there will be post-operative slippage of the implant from its proper intervertebral position. The implant is made of an artificial material that can be fully sterilized prior to implantation.

The invention also includes a disk

-5-

implantation kit containing an implant and a
delivery tool useful in performing the
intervertebral placement of the implant during a
surgical procedure. The disk implant may be
5 provided in a presterilized, prepackaged form held
by the delivery tool, which can be used without
repositioning the implant in the tool. The
implantation tool carries the implant so as to avoid
10 damage to the implant prior to and during surgical
implantation. The tool also permits the surgeon to
securely hold the implant during implantation and to
easily place it at the proper location.

In accordance with the invention, a spinal
disk implant comprises a solid body having four
15 faces arranged to define a right-rectangular body,
including two opposed side faces and two opposed
transverse faces. At least one of the transverse
faces is provided with a central region with
three-dimensional features thereon and an anterior
20 platform region lying along an anterior margin of
the transverse face. A convexly curved anterior
face defines one end of the right-rectangular body,
and a posterior face defines the other end of the
right-rectangular body. The solid body is made of a
25 material selected from the group consisting of a
ceramic, a metal, a polymer, and a composite
material.

Stated more formally, the spinal disk implant
is a solid body made of a biocompatible synthetic
30 material and has a convexly (outwardly) curved
anterior face with a curvature of about that of the
anterior surface of a human vertebra. The anterior
face has an anterior face lateral margin and a
curved anterior face transverse margin.

35 The disk implant also has a posterior face
spaced apart from the anterior face with a posterior

-6-

face lateral margin and a posterior face transverse margin. The posterior face may be flat or convexly curved.

5 A pair of generally parallel, spaced apart, opposed side faces extend between the lateral margins of the anterior face and the posterior face.

10 A pair of spaced apart, opposed transverse faces extend between the transverse margins of the anterior face and the posterior face. The transverse faces may be flat or convexly curved. The transverse faces may be parallel or angled toward each other. Each transverse face has an anterior platform. At least one of the transverse faces, and preferably both transverse faces, has an engagement region located posterior of the anterior platform with three-dimensional features thereon. The width of the anterior platform is about that of the thickness of anterior cortical bone of a human vertebra.

20 In a preferred form, an implant is made available to surgeons in a kit prepackaged with a delivery tool comprising means for holding the implant and then controllably releasing the implant. The delivery tool preferably includes a base and a pair of flexible opposed arms extending from the base. The arms are spaced and dimensioned to releasably hold the implant therebetween. This configuration of delivery tool avoids the need for threaded bores or other types of grasping features on the implant, as these types of features may significantly weaken the implant. A delivery tool handle is also provided so that the tool can be easily manipulated by the surgeon. In one embodiment, a release band extending between the distal ends of the arms holds the implant to the delivery tool. The release band has a breakable

25
30
35

-7-

weak link, which is readily parted with a slight tug after the implant has been properly positioned by the surgeon.

In the preferred kit form, the delivery tool
5 is made of a sterilizable plastic. The kit is provided with the implant grasped between the arms of the delivery tool, in a presterilized package. The handle of the delivery tool may also be in the package integral with the delivery tool, or may be
10 provided separately. The implants are provided in a range of sizes for different size persons and different locations of the disk to be replaced. The surgeon makes a preoperative estimation of the range of sizes most likely to be required, and delivery
15 tool/implant sets spanning this range are prepared for surgery. During the implant procedure, the surgeon can select the one implant that is most appropriate, and substitute another if for some reason, typically incorrect dimensions, the first
20 choice is not operable. The surgeon need not modify the shape of the implant, but uses it directly from the package. The implant is placed into the correct position using the delivery tool, the implant is controllably released, and the delivery tool is
25 removed and discarded. This approach minimizes the time of the operation, thereby decreasing the chances of complications for the patient.

The present invention provides an important advance in the art of spinal disk implants. The
30 implant itself is configured to provide the most reliable and secure load path through the reconstructed region, and also to securely hold its position post-operatively. The delivery tool encourages the proper placement of the implant
35 during surgery, and also aids in achieving orderly functioning of the operating theater with reduced

-8-

risk of patient complications. Other features and advantages of the invention will be apparent from the following more detailed description of the preferred embodiments, taken in conjunction with the accompanying drawings, which illustrate, by way of example, the principles of the invention.

BRIEF DESCRIPTION OF THE DRAWINGS

- Figure 1 is a side elevational view of the spine;
- 10 Figure 2 is an enlarged plan view of a cervical vertebra;
- Figure 3 is a perspective view of a first embodiment of a spinal disk implant;
- 15 Figure 4 is a plan view of the spinal disk implant of Figure 3;
- Figure 5 is a side elevational view of one form of the spinal disk implant of Figure 3;
- Figure 6 is a side elevational view of a second form of the spinal disk implant of Figure 3;
- 20 Figure 7 is a side elevational view of a third form of the spinal disk implant of Figure 3;
- Figure 8 is a plan view of a cervical vertebra similar to the view of Figure 2, with the properly positioned spinal disk implant of Figure 3 indicated in phantom lines;
- 25 Figure 9 is a perspective view of a second embodiment of a spinal disk implant;
- Figure 10 is a plan view of an implant delivery tool with the disk implant of Figure 3;
- 30 Figure 11 is a plan view of an implant delivery tool with the disk implant of Figure 9;
- Figure 12 is an elevational view of one form of the implant tool of Figure 10;

-9-

Figure 13 is an elevational view of another form of the implant tool of Figure 10;

Figure 14 is a plan view of the implant delivery tool of Figure 13 and implant of Figure 10, with attached handle;

Figure 15 is a perspective view of another form of the implant delivery tool; and

Figure 16 is a plan view of the implant delivery tool of Figure 15, with an integrally formed handle.

DETAILED DESCRIPTION OF THE PREFERRED EMBODIMENTS

Figure 1 depicts a human spine 20. The spine 20 is formed from thirty-three individual vertebrae 22, with the 24 uppermost vertebrae in most cases separated by intervertebral disks 24. The spine 20 is described as having an anterior side 26 and a posterior side 28.

Figure 2 depicts one of the vertebrae, here one of the cervical vertebrae 30. (A cervical vertebra has been chosen for illustration, but the other vertebra are similar in relevant aspects and differ primarily in details of geometry.) The vertebra 30 includes a vertebral body region 32, and various processes 34. A cervical disk 36, indicated in phantom lines, overlies the vertebral body region 32 in the natural condition. A central opening through the vertebra 30 is the foramen 38, through which the spinal cord and the spinal nerve roots pass.

The vertebral body region 32 includes two distinct types of natural bone. A layer of cortical bone is found at an outer edge 42 of the vertebral body region 32. The cortical bone is a hard, dense

-10-

type of bone, having high strength. A central portion 44 of the vertebral body region 32 is made of cancellous bone, which is a more resilient, weaker, and less dense type of bone.

5 A spinal disk implant 50, shown in Figures 3-7 in several variations, has a structure designed for implantation between the vertebral body regions of two adjacent vertebrae 22. This spinal disk implant 50 is readily inserted between the vertebrae during a surgical procedure, produces a load-bearing 10 construct in which the majority of the load on the spine 20 is borne through the cortical bone, and is highly resistant to dislocation away from its proper position between the vertebrae.

15 Referring to Fig. 3-5, the spinal disk implant 50 is a solid body having an anterior face 52 and an oppositely disposed posterior face 54. The anterior face 52 of the implant 50 is convexly curved, to generally match the shape of the anterior 20 portion of the outer edge 42 of the vertebra 22 (Figure 2). As discussed herein, several features of the implant are configured to be approximately the same shape or dimension as features of the vertebrae. It is recognized that different persons 25 and different vertebrae have differing shapes and dimensions, and the implant features are selected to be close, but not necessarily exact, matches for those shapes and dimensions. As discussed subsequently, the implant may be made available to 30 surgeons in a range of sizes to accommodate extremes and normal shapes and dimensions that are encountered in different persons.

The anterior face 52 has an anterior face lateral margin 56 and an anterior face transverse 35 margin 58. The term "margin" is used herein generally in the same sense as in the "margin" of a

-11-

page, its edge region. Similarly, the posterior face has a posterior face lateral margin 60 and a posterior face transverse margin 62.

5 A pair of spaced apart, opposed, generally parallel side faces 64 and 66 extend between the respective anterior face lateral margins 56 and the posterior face lateral margins 60.

10 A pair of spaced apart, transverse faces 68 and 70 extend between the respective anterior face transverse margins 58 and the posterior face transverse margins 62. In the embodiment of Figure 5, the transverse faces 68 and 70 are parallel to each other, but that is not necessarily the case. Each transverse face (68, 70) has an anterior
15 platform 72 thereon. When the implant 50 is surgically implanted, the anterior platform 72 with the anterior face 52 generally aligned with the anterior side 26 of the vertebra 22, the anterior platform is in facing relationship with the cortical
20 bone region of the vertebra. The anterior platform 72 is therefore made to be about the same width as the cortical bone region of the vertebra.

An engagement region 74 is located on the transverse faces 68, 70 posteriorly of the anterior
25 platform 72. The engagement region 74 has one or more three-dimensional features extending above the general level of the transverse faces 68, 70. In the embodiment of Figures 3-5, these three-dimensional features are pyramids 76. After
30 the implant 50 is implanted between two vertebrae 22, as shown in Figure 8, the pyramidal engagement features contact and engage the cancellous bone of the vertebrae in the central portion 44 of the vertebrae. Since the cancellous bone is softer than
35 the cortical bone, the engagement features sink into the cancellous bone as load is applied and over time

-12-

after the patient is again carrying weight through the spine. This engagement prevents the implant 50 from shifting its position and moving away from the proper position established by the surgeon.

5 The implant is made of a ceramic, a metal, a polymer, or a composite material. The implant 50 is desirably made from a material that, after surgical implantation, bonds to the natural bone of the adjacent vertebrae to form a rigid structure. The
10 implant is preferably made from a ceramic, most preferably the ceramic calcium hydroxylapatite, having a chemical formula $\text{Ca}_{10}(\text{PO}_4)_6(\text{OH})_2$. The use of such materials in implants is known, see for example US Patent 4,863,476. The implant 50 may
15 also be made from a composite material such as the carbon-fiber reinforced plastics disclosed in US Patent 4,904,261. The implant may also be made from a biocompatible orthopedic polymer ("BOP"), such as a copolymer of methylmethacrylate and N-vinylpyrrolidone and calcium gluconate, reinforced with
20 polyamide fibers. Such a material is known in the art, and is described, for example, in G. Lozes et al., "Discectomies of the Lower Cervical spine Using Interbody Biopolymer (BOP) Implants", Acta Neurochir (Wien),
25 vol. 96, pages 88-93 (1989). The implant may be made from naturally occurring coralline. In some instances, the implant may be made from an uncoated biocompatible metal, such as titanium or a titanium alloy such as Ti-6Al-4V. The implant may
30 also be made from such a metal coated with a layer of ceramic or a porous metal coating of sintered beads, mesh, or an amorphous porous layer.

 The implant 50 may be made at least in part microporous, so that it functions as a delivery
35 vehicle for antibiotics or bone stimulating factors such as bone morphogenic protein or osteogenin,

-13-

which are introduced into the implant before implantation surgery. In the case of the preferred ceramic hydroxylapatite construction of the implant, the density and/or surface morphology of the ceramic can be varied in the sintering process so that it retains the materials to be delivered. The delivery of chemicals by this approach is known in the art, see, for example, H.A Benghuzzi et al., "The Effects of Density of the Ceramic Delivery Devices on Sustained Release of Androgens in Castrated Rodents," 17th Annual Meeting of the Society for Biomaterials, May 1-5, 1991, page 159.

In another approach, a coated implant is prepared by providing a piece of metal, such as titanium or titanium alloy, in the shape of the implant but slightly undersize in all dimensions. A coating of ceramic, metal, or polymer, of the types described previously, is applied over the piece of metal to enlarge the implant to the proper final dimensions.

Figure 6 is an elevational view of another embodiment of the implant 50, having several structural variations from that discussed previously. First, in the embodiment of Figure 6 the transverse faces 68, 70 are not parallel to each other, but rather are tapered from the anterior end toward the more closely spaced posterior end. Second, the engagement region 74 has engagement features and are depressions 78 below the general level of the transverse face 68. Third, the engagement region 74 is found on only one of the transverse faces, illustrated as the transverse face 68. Consequently, unlike the symmetrical version of Figure 5, the embodiment of Figure 6 is asymmetric about a plane halfway between the transverse faces 68, 70.

-14-

Fourth, the embodiment of Figure 6 has a graded-porosity structure, indicated in the drawing as a dense central region 80 and a less dense, partly porous face region 82. The face region 82 extends about 0.1-3.0 millimeters, preferably about 0.5-1.0 millimeters, from the surface of each transverse face 78, 80. In this embodiment, the entire implant 50 is made of calcium hydroxylapatite ("HA"). The HA in the dense central region 80 has a density of about 95-100 percent of the theoretical density, with very little porosity. The HA in the face region 82 is intentionally somewhat porous, with a density of about 60-95 percent of the theoretical density. The pore sizes in the face region 82 are about 50-500 micrometers in diameter, most preferably about 100-250 micrometers in diameter.

Figure 7 presents another structural modification to the basic implant 50. In this embodiment, the transverse faces 68, 70 are convexly bowed outwardly. The bowing may be from the anterior end to the posterior end, or from side to side, or both.

Another form of spinal disk implant 50 is shown in Figure 9. This embodiment has a convexly curved posterior face 54, as well as a convexly curved anterior face 52. With the convex curvature on both ends, the implant of Figure 9 may be made end-to-end symmetric, if desired. If the implant is made end-to-end symmetric, then a posterior platform 84 is provided symmetric with the anterior platform 72. In the design of Figure 3, a posterior platform 84 is normally present, but is not of any particular width.

Figures 6 and 7 present a number of design variations for the implant 50. These variations

-15-

have been illustrated together for convenience. However, they may be used or not used in any combination that may be convenient and appropriate in a particular circumstance.

5 The invention also extends to an implant delivery tool 100 for use in the surgical operation to implant the implant 50. As illustrated in Figs. 10-13, the tool 100 has a base 101, and a pair of flexible opposed arms 102 extending from the base
10 101. The arms 102 are spaced apart and dimensioned to releasably grasp and hold the implant 50 therebetween. Figure 10 illustrates the configuration of the tool 100 for use in holding the implant 50 pictured in Figure 3, having only the
15 anterior face curved. Figure 11 illustrates the configuration of tool 100 for use in holding the implant 50 pictured in Figure 9, having both the anterior and posterior faces curved. Other configurations could be provided as appropriate.

20 A release band 104 is fastened to the delivery tool 100 and extends around a portion of the implant 50 to releasably hold it in place on the delivery tool. In the preferred form, the release band 104 extends from the tips 106 of the arms 102
25 and around the end of the implant 50 to hold it in place between the arms 102. Equivalently, the release band could extend between other portions of the delivery tool.

30 A breakable link is provided in the structure that holds the implant to the delivery tool. The breakable link permits the implant to be controllably released from the delivery tool. In the preferred approach, a breakable weak link 108 is provided in the release band 104, so that the
35 release band 104 can be broken with a slight tug on the tool 100 after the implant is properly

-16-

positioned between the vertebrae during implantation, leaving the implant at a selected position when the tool is withdrawn. Equivalently, the breakable link could be provided in one of the arms or elsewhere.

5 It is possible that in some cases the frictional engagement between the implant 50 and the arms 102 will not be sufficient to prevent the implant 50 from tilting or sliding in an end-to-end manner. To prevent such tilting or sliding, a stabilizing lip 110 can extend outwardly from an edge of the base 101. The stabilizing lip, shown in Figure 12, engages the proximate end of the implant 50 and prevents it from tilting or sliding in an end-to-end fashion. The stabilizing lip 110 may also be provided with an optional stop 111 on its exterior edge that aids the surgeon in positioning the implant during the implantation operation. As the delivery tool 100 is used by the surgeon to insert the implant 50 between two vertebrae, the stop 111 engages the anterior edge of one of the vertebra when the implant has reached the proper position. In a further embodiment shown in Figure 13, two oppositely disposed stabilizing lips 110 (in this case having no stops 111) are provided to hold the implant 50 even more securely. The stabilizing lips can be tapered to ease their insertion between the vertebral bodies during implant placement.

15 An engagement tip 112 extends rearwardly from the base 101. This tip 112 engages with a handle, to be described subsequently. The tip may have any appropriate form that cooperates with the handle, as shown in the figures.

20 It has been found that in some cases it is preferred not to utilize the release band 104. Figure 15 illustrates a preferred form of the

-17-

delivery tool 100 that is used in these cases. The structure of the delivery tool of Figure 15 is similar in most respects to that shown in Figure 10, with a base 101, arms 102, stabilizing lip 110, and engagement tip 112. In this case, however, the tips 5 106 of the arms 102 are curved inwardly to conform to the shape of the end of the implant (not shown in Figure 15). This form of the delivery tool 100 can be made so that the implant, when in place between the arms 102, forces the arms to spread slightly and 10 thereby hold the implant securely therebetween. When the implant has been placed between the vertebrae, the delivery tool is withdrawn so that the tips 106 ride over the sides of the implant, pushing the arms 102 further outwardly. The 15 delivery tool 100 is thereby readily removed from the implant.

The base 101, arms 102, release band 104 (where present), weak link 108 (where present), engagement tip 112, and stabilizing lip or lips 110 20 are preferably made of a sterilizable plastic such as Ultem (R) available from General Electric Plastics, or Delrin (R) available from DuPont. The tool 100 can be made in one piece by injection molding, and is therefore relatively inexpensive and 25 disposable. The release band 104, when present, is a thin ribbon of such plastic, and the weak link 108 is a constricted region of the ribbon that can be easily broken by a tug on the tool 100.

The cooperative design of the implant 50 and 30 the delivery tool 100 is an important feature of the invention. In the past, it has been known in some cases to use a delivery tool that threadably engaged with a threaded bore in the implant. Studies associated with the present invention have 35 demonstrated that a bore, whether threaded or not,

-18-

in an implant 50, made of a material of relatively low ductility, can significantly weaken the implant 50 even though it is to be used in compression. Avoiding bores and threaded bores in the implant, and provision of an operable delivery tool for this design limitation, adds to the strength and reliability of the implant after implantation.

Figure 14 depicts a reusable handle 114 that can be used to place the implant 50 in the desired location during a surgical procedure. The handle 114 has a forward end 116 with a recess 118 therein, dimensioned to firmly but releasably receive the engagement tip 112 of the tool 100. A grip 120 is provided in the intermediate portion of the handle 114, permitting the surgeon to comfortably hold the handle 114 and thence the tool 100 and the implant 50 mounted therein. A blunt butt end 122 of the handle 114 is provided so that the surgeon may strike it lightly with a surgical hammer if necessary to urge the implant 50 into place between two vertebrae that have been slightly spread apart from their normal spacing during the surgical procedure.

Figure 16 illustrates another embodiment, wherein a handle 115 is integral with the delivery tool 100 and is therefore not reusable. In this embodiment, the handle is packaged in the sterile package with the delivery tool and the handle. In this case, the handle 115 would preferably be made of an injection molded polymer such as a polycarbonate, while the handle 114 of Figure 14 could be made of polymer or metal. Figures 14 and 16 illustrate the handles in conjunction with particular embodiments of the delivery tool, but the approaches are interchangeable so that any type of delivery tool could be provided with either a

-19-

permanent, integral handle or a reusable handle. The lengths and other dimensions of the handles may be varied as desired for particular applications. The handle lengths are depicted in the drawings as
5 relatively shorter than may be desired in practice, in order to show the other features in larger scale.

In a preferred embodiment, the delivery tool and implant are furnished together as a kit, for the convenience of the surgeon. The kit allows
10 sterilization of the tool and implant to be readily accomplished either by the manufacturer or in the operating room. The kit form also allows the hospital to conveniently stock a range of sizes and configurations of implant that might be needed,
15 giving the surgeon great latitude in the action taken during the procedure, while minimizing the duration of the procedure.

It is preferred to package the delivery tool and implant in a presterilized package, indicated in
20 broken lines as the package 113 in Figs. 10 and 11. The package may also be furnished so that it and the contents of the package can be sterilized in the operating room, or such that the delivery tool and implant can be removed from the package and
25 sterilized in the operating room. The first approach is preferred, because of its convenience.

To use the kit form of the invention, the required sizes or possible range of implant sizes of the kits are made available in the operating room, preferably in the presterilized package form.
30 During the surgical procedure, the surgeon selects the required implant, and affixes the delivery tool 100 to the handle 114 using the engagement tip 112. The surgeon then uses the handle 114 to manipulate
35 the implant 50 into the proper intervertebral position, tapping the butt end 122 if necessary.

-20-

When the implant 50 is properly positioned, the vertebrae are allowed to relax slightly back to their normal positions, capturing the implant 50 therebetween. If the surgeon is satisfied with the placement, he or she tugs on the handle 114 to break the weak link 108. The entire delivery tool 100 and handle 114 are withdrawn, and the placement is complete. If, on the other hand, the surgeon is not satisfied with the implant position, the vertebrae can be tensioned to spread them slightly and to permit removal of the implant. The procedure is repeated with another prepackaged implant and delivery tool available in the operating room.

The present approach provides a spinal disk implant and delivery tool for its implantation. The implant is of a design and material of construction selected to improve the fusion of the adjacent vertebrae, and to permit the implant to be readily implanted. Although particular embodiments of the invention have been described in detail for purposes of illustration, various modifications may be made without departing from the spirit and scope of the invention. Accordingly, the invention is not to be limited except as by the appended claims.

-21-

CLAIMS

What is claimed is:

1. A spinal disk implantation kit,
comprising:
 - 5 a spinal disk implant shaped and dimensioned
to fit between two vertebrae of the human body after
an intervertebral disk is removed; and
 - an implant delivery tool comprising means for
holding the implant in compression and then
10 controllably releasing the implant.
2. The kit of claim 1, wherein the implant
delivery tool comprises
 - a base, and
 - 15 a pair of spaced apart, flexible opposed arms
extending from the base, a spacing between the arms
being dimensioned to releasably hold the implant
therebetween.
3. The kit of claim 1, wherein the means for
holding and then controllably releasing includes at
20 least one breakable restraint having means for
holding the implant to the delivery tool and for
controllably breaking after the implant is placed
between the vertebrae and the delivery tool is being
withdrawn.
- 25 4. The kit of claim 1, wherein the implant
delivery tool comprises
 - an implant holder having a pair of laterally
spaced arms dimensioned to receive the implant in
compression therebetween,
 - 30 an implant delivery tool handle, and
 - means for fixing the implant holder to the

-22-

implant delivery tool handle.

5. The kit of claim 4, wherein the means for fixing includes

5 means for removably fixing the implant holder to the implant delivery tool handle.

6. The kit of claim 1, wherein the implant and the delivery tool are sterile, and further including

10 a sterile container that contains the implant and the delivery tool.

7. A spinal disk implant, comprising a solid body having

15 a convexly curved anterior face, the anterior face having a curvature of about that of the anterior surface of a human vertebra and having an anterior face lateral margin and a curved anterior face transverse margin;

20 a posterior face spaced apart from the anterior face and having a posterior face lateral margin and a posterior face transverse margin;

a pair of generally parallel, spaced apart, opposed side faces extending between the lateral margins of the anterior face and the posterior face; and

25 a pair of spaced apart, opposed transverse faces extending between the transverse margins of the anterior face and the posterior face, each transverse face having an anterior platform and at least one of the transverse faces having an engagement region located posterior of the anterior platform, the engagement region having three-dimensional features thereon raised above the transverse face, a width of the anterior platform

30

-23-

being about that of a thickness of anterior cortical bone of a human vertebra,
the spinal disk implant being made of a biocompatible synthetic material.

5 8. The implant of claim 7, wherein the solid body is formed of a ceramic, a metal, a polymer, or a composite material.

 9. The implant of claim 7, wherein the solid body is formed of calcium phosphate,
10 hydroxylapatite, titanium, or a titanium alloy.

 10. The implant of claim 7, wherein the solid body comprises
 four faces arranged to define a right-rectangular body, including two opposed side
15 faces and two opposed transverse faces, at least one of the transverse faces having a central region with three-dimensional features thereon raised above the transverse face and an anterior platform region lying along an anterior margin of the transverse
20 face;

 a convexly curved anterior face defining one end of the right-rectangular body; and

 a posterior face defining the other end of the right-rectangular body.

FIG. 1

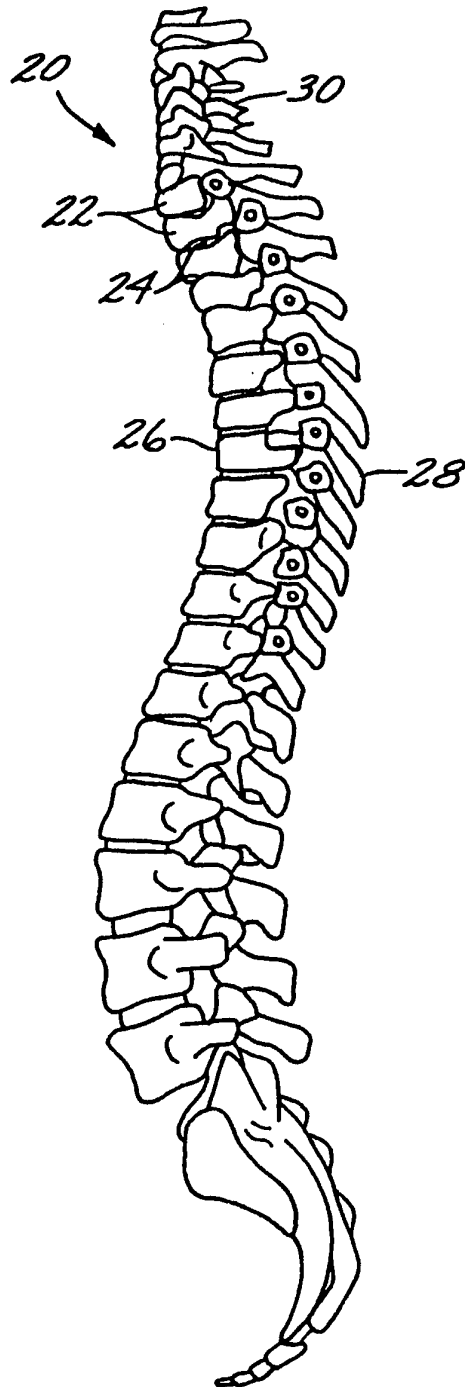
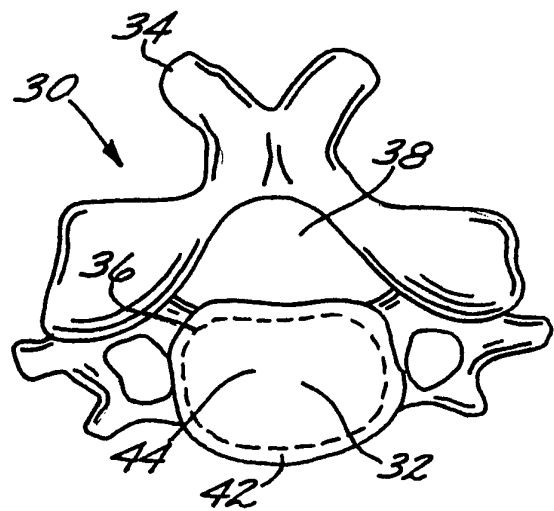

FIG. 2



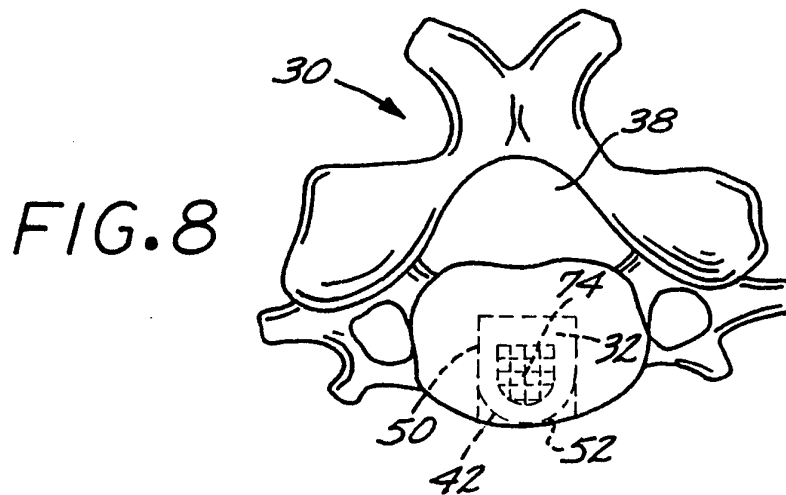
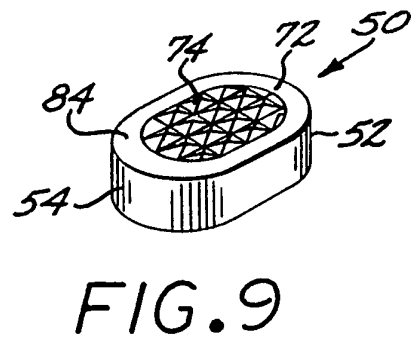
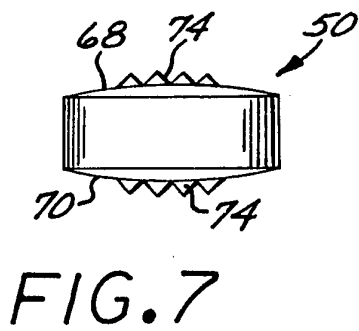
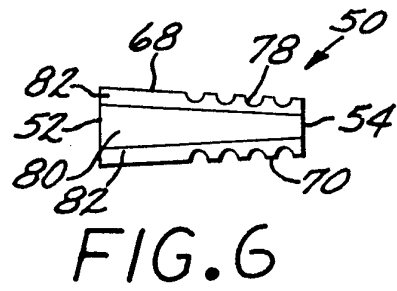
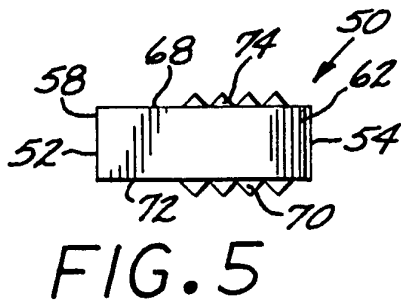
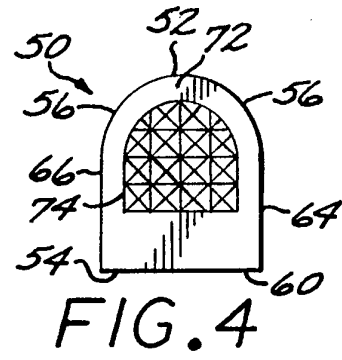
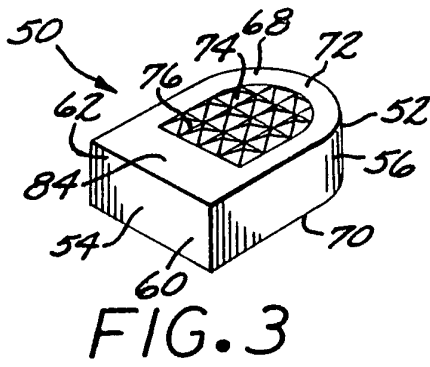

FIG. 10

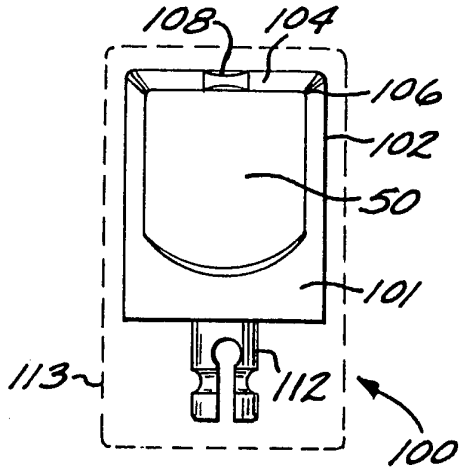

FIG. 11

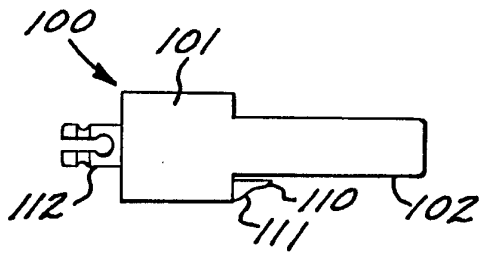
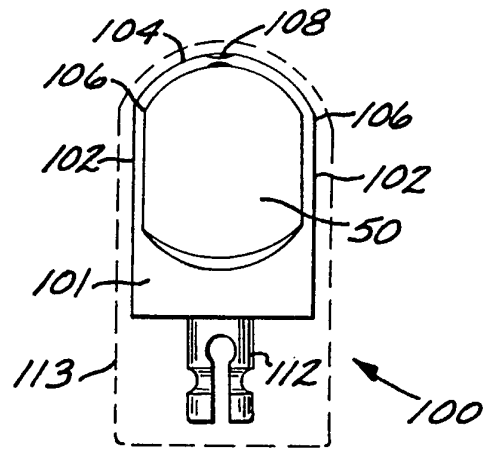

FIG. 12

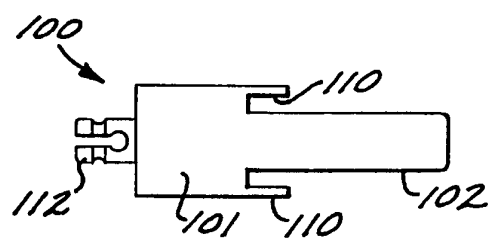

FIG. 13

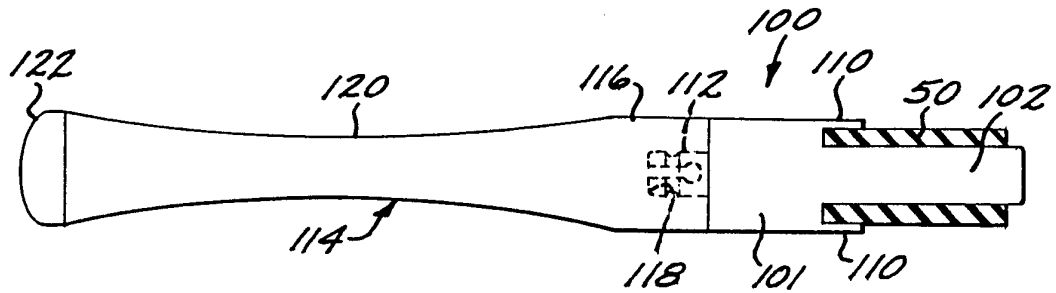

FIG. 14

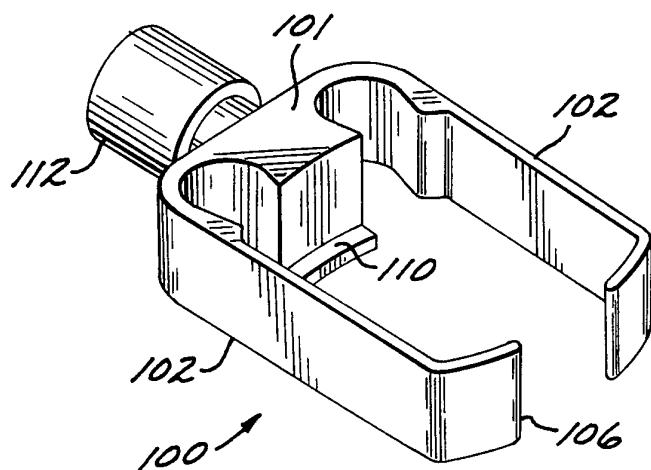

FIG. 15

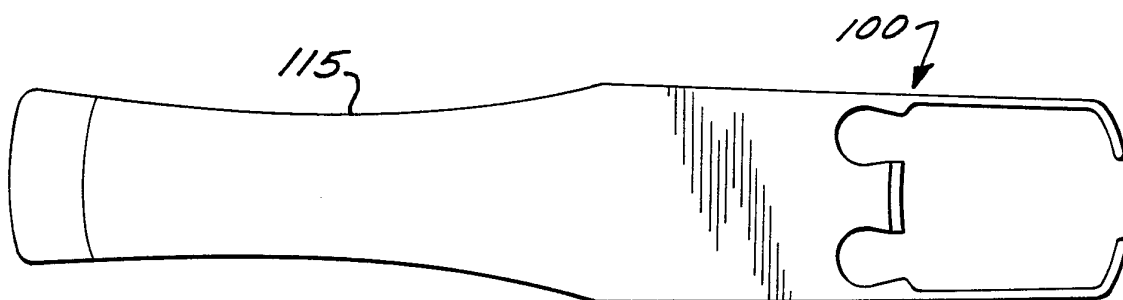
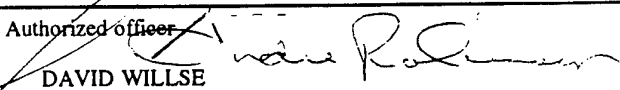

FIG. 16

INTERNATIONAL SEARCH REPORT

International application No.
PCT/US94/13709

<p>A. CLASSIFICATION OF SUBJECT MATTER IPC(6) :A61F 2/44 US CL :606/61, 99; 623/17 According to International Patent Classification (IPC) or to both national classification and IPC</p>		
<p>B. FIELDS SEARCHED Minimum documentation searched (classification system followed by classification symbols) U.S. : 402/2; 606/61, 99, 104, 105, 206; 623/17</p>		
<p>Documentation searched other than minimum documentation to the extent that such documents are included in the fields searched NONE</p>		
<p>Electronic data base consulted during the international search (name of data base and, where practicable, search terms used) NONE</p>		
<p>C. DOCUMENTS CONSIDERED TO BE RELEVANT</p>		
Category*	Citation of document, with indication, where appropriate, of the relevant passages	Relevant to claim No.
X, P	US, A, 5,306,309, (WAGNER ET AL.), 26 April 1994. See all the figures.	1-10
X --- Y	US, A, 5,192,327, (BRANTIGAN), 09 March 1993. See Figs. 6, 13 and 14, column 3 lines 9-15, column 4 lines 4 and 5; and column 7 lines 4-6.	1, 7-10 ----- 2, 4-6
X --- Y	US, A, 4,997,432, (KELLER), 05 March 1991. See Figs. 2-7.	1, 2, 4, 5 ----- 6
<p><input type="checkbox"/> Further documents are listed in the continuation of Box C. <input type="checkbox"/> See patent family annex.</p>		
<p>* Special categories of cited documents:</p> <p>*A* document defining the general state of the art which is not considered to be part of particular relevance</p> <p>*E* earlier document published on or after the international filing date</p> <p>*L* document which may throw doubts on priority claim(s) or which is cited to establish the publication date of another citation or other special reason (as specified)</p> <p>*O* document referring to an oral disclosure, use, exhibition or other means</p> <p>*P* document published prior to the international filing date but later than the priority date claimed</p>		<p>*T* later document published after the international filing date or priority date and not in conflict with the application but cited to understand the principle or theory underlying the invention</p> <p>*X* document of particular relevance; the claimed invention cannot be considered novel or cannot be considered to involve an inventive step when the document is taken alone</p> <p>*Y* document of particular relevance; the claimed invention cannot be considered to involve an inventive step when the document is combined with one or more other such documents, such combination being obvious to a person skilled in the art</p> <p>* & * document member of the same patent family</p>
<p>Date of the actual completion of the international search 07 FEBRUARY 1995</p>		<p>Date of mailing of the international search report 20 MAR 1995</p>
<p>Name and mailing address of the ISA/US Commissioner of Patents and Trademarks Box PCT Washington, D.C. 20231 Facsimile No. (703) 305-3230</p>		<p>Authorized officer  DAVID WILLSE Telephone No. (703) 308-2903</p>