

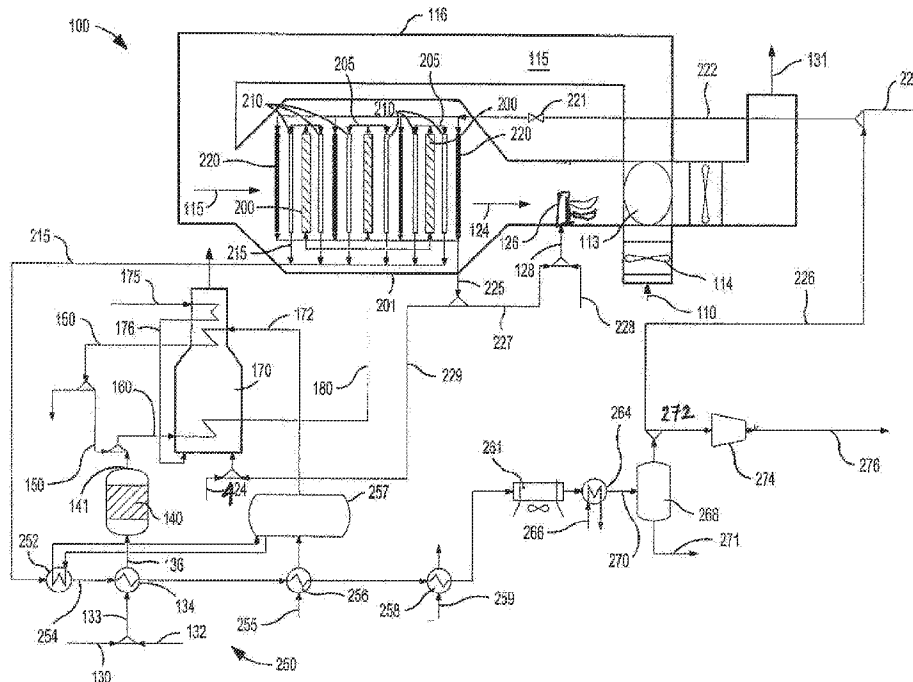

(86) Date de dépôt PCT/PCT Filing Date: 2014/12/01
 (87) Date publication PCT/PCT Publication Date: 2015/06/11
 (45) Date de délivrance/Issue Date: 2020/02/25
 (85) Entrée phase nationale/National Entry: 2016/04/06
 (86) N° demande PCT/PCT Application No.: US 2014/067928
 (87) N° publication PCT/PCT Publication No.: 2015/084729
 (30) Priorité/Priority: 2013/12/02 (US61/910,697)

(51) Cl.Int./Int.Cl. *C01B 3/38* (2006.01),
B01J 8/06 (2006.01)
 (72) Inventeurs/Inventors:
CHAKRAVARTI, SHRIKAR, US;
DRNEVICH, RAYMOND F., US;
STUCKERT, INES C., US;
SHAH, MINISH M., US
 (73) Propriétaire/Owner:
PRAXAIR TECHNOLOGY, INC., US
 (74) Agent: AIRD & MCBURNEY LP

(54) Titre : PROCÉDE ET SYSTÈME DE PRODUCTION D'HYDROGÈNE AU MOYEN D'UN SYSTÈME DE REFORMAGE A BASE DE MEMBRANE DE TRANSPORT D'OXYGÈNE AVEC UN REFORMAGE SECONDAIRE
 (54) Title: METHOD AND SYSTEM FOR PRODUCING HYDROGEN USING AN OXYGEN TRANSPORT MEMBRANE BASED REFORMING SYSTEM WITH SECONDARY REFORMING



(57) **Abrégé/Abstract:**

A method and system for producing hydrogen using an oxygen transport membrane based reforming system is disclosed that carries out a primary reforming process within a reforming reactor, and a secondary reforming process within a reactively driven

(57) **Abrégé(suite)/Abstract(continued):**

and catalyst containing oxygen transport membrane reactor with or without an auxiliary source of heat to support primary reforming process within the reforming reactor to first form a synthesis gas product. The auxiliary source of heat is disposed within the oxygen transport membrane based reforming system proximate to the reforming reactors and comprises an auxiliary oxygen transport membrane reactor or a ceramic burner. The synthesis gas product is further treated in a separate high temperature water gas shift reactor and optionally in a separate low temperature water gas shift reactor. Hydrogen is produced from the resulting hydrogen-enriched gas using hydrogen PSA.

(12) INTERNATIONAL APPLICATION PUBLISHED UNDER THE PATENT COOPERATION TREATY (PCT)

CORRECTED VERSION

(19) World Intellectual Property
Organization
International Bureau(10) International Publication Number
WO 2015/084729 A9(43) International Publication Date
11 June 2015 (11.06.2015)

- (51) International Patent Classification:
C01B 3/38 (2006.01) *B01J 8/06* (2006.01)
- (21) International Application Number:
PCT/US2014/067928
- (22) International Filing Date:
1 December 2014 (01.12.2014)
- (25) Filing Language: English
- (26) Publication Language: English
- (30) Priority Data:
61/910,697 2 December 2013 (02.12.2013) US
- (71) Applicant: **PRAXAIR TECHNOLOGY, INC.** [US/US];
39 Old Ridgebury Road, Danbury, CT 06810 (US).
- (72) Inventors: **CHAKRAVARTI, Shrikar**; 12 Gina Meadows, East Amherst, NY 14051 (US). **DRNEVICH, Raymond, F.**; 5850 Creekview Drive, Clarence Center, NY 14032 (US). **STUCKERT, Ines, C.**; 2300 Fix Road, Grand Island, NY 14072 (US). **SHAH, Minish, M.**; 84 South Castlerock Lane, East Amherst, NY 14051 (US).
- (74) Agents: **MANCINI, Ralph, J.** et al.; Praxair, Inc., 39 Old Ridgebury Road, Danbury, CT 06810 (US).

(81) Designated States (*unless otherwise indicated, for every kind of national protection available*): AE, AG, AL, AM, AO, AT, AU, AZ, BA, BB, BG, BH, BN, BR, BW, BY, BZ, CA, CH, CL, CN, CO, CR, CU, CZ, DE, DK, DM, DO, DZ, EC, EE, EG, ES, FI, GB, GD, GE, GH, GM, GT, HN, HR, HU, ID, IL, IN, IR, IS, JP, KE, KG, KN, KP, KR, KZ, LA, LC, LK, LR, LS, LU, LY, MA, MD, ME, MG, MK, MN, MW, MX, MY, MZ, NA, NG, NI, NO, NZ, OM, PA, PE, PG, PH, PL, PT, QA, RO, RS, RU, RW, SA, SC, SD, SE, SG, SK, SL, SM, ST, SV, SY, TH, TJ, TM, TN, TR, TT, TZ, UA, UG, US, UZ, VC, VN, ZA, ZM, ZW.

(84) Designated States (*unless otherwise indicated, for every kind of regional protection available*): ARIPO (BW, GH, GM, KE, LR, LS, MW, MZ, NA, RW, SD, SL, ST, SZ, TZ, UG, ZM, ZW), Eurasian (AM, AZ, BY, KG, KZ, RU, TJ, TM), European (AL, AT, BE, BG, CH, CY, CZ, DE, DK, EE, ES, FI, FR, GB, GR, HR, HU, IE, IS, IT, LT, LU, LV, MC, MK, MT, NL, NO, PL, PT, RO, RS, SE, SI, SK, SM, TR), OAPI (BF, BJ, CF, CG, CI, CM, GA, GN, GQ, GW, KM, ML, MR, NE, SN, TD, TG).

Published:

— with international search report (Art. 21(3))

(48) Date of publication of this corrected version:

14 January 2016

[Continued on next page]

(54) Title: METHOD AND SYSTEM FOR PRODUCING HYDROGEN USING AN OXYGEN TRANSPORT MEMBRANE BASED REFORMING SYSTEM WITH SECONDARY REFORMING

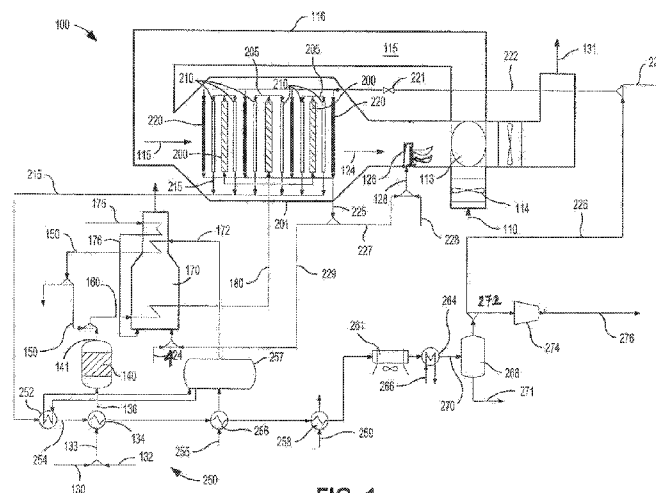

FIG. 1

(57) Abstract: A method and system for producing hydrogen using an oxygen transport membrane based reforming system is disclosed that carries out a primary reforming process within a reforming reactor, and a secondary reforming process within a reactively driven and catalyst containing oxygen transport membrane reactor with or without an auxiliary source of heat to support primary reforming process within the reforming reactor to first form a synthesis gas product. The auxiliary source of heat is disposed within the oxygen transport membrane based reforming system proximate to the reforming reactors and comprises an auxiliary oxygen transport membrane reactor or a ceramic burner. The synthesis gas product is further treated in a separate high temperature water gas shift reactor and optionally in a separate low temperature water gas shift reactor. Hydrogen is produced from the resulting hydrogen-enriched gas using hydrogen PSA.

WO 2015/084729 A9

WO 2015/084729 A9 

(15) Information about Correction:
see Notice of 14 January 2016

METHOD AND SYSTEM FOR PRODUCING HYDROGEN
USING AN OXYGEN TRANSPORT MEMBRANE BASED REFORMING SYSTEM
WITH SECONDARY REFORMING

Field of the Invention

(0001) The present invention relates to a method and system for production of hydrogen utilizing an oxygen transport membrane based reforming system that provides both primary and secondary reforming. More particularly, a method and system for hydrogen production utilizing an oxygen transport membrane based reforming system, water gas shift reactor and hydrogen PSA.

Background

(0002) Synthesis gas containing hydrogen and carbon monoxide is used for a variety of industrial applications, for example, the production of hydrogen, chemicals and synthetic fuels. Conventionally, the synthesis gas is produced in a fired reformer in which natural gas and steam are reformed in nickel catalyst containing reformer tubes at high temperatures (e.g., 850 °C to 1000 °C) and moderate pressures (e.g., 16 to 30 bar) to produce the synthesis gas. The endothermic heating requirements for steam methane reforming reactions occurring within the reformer tubes are provided by burners firing into the furnace that are fueled by part of the natural gas. In order to increase the hydrogen content of the synthesis gas produced by the steam methane reforming (SMR) process, the synthesis gas can be subjected to water-gas shift reactions to react steam with the carbon monoxide in the synthesis gas. Typically hydrogen is recovered by treating the hydrogen rich stream in a H₂ PSA. The tail gas from the H₂ PSA is utilized as a fuel in the fired reformer to facilitate endothermic reforming reactions.

(0003) A well-established alternative to steam methane reforming is the non-catalytic partial oxidation process (POx) whereby a sub-stoichiometric amount of oxygen is allowed to react with the natural gas feed creating steam and carbon dioxide at high

temperatures. The high temperature residual methane is reformed through reactions with the high temperature steam and carbon dioxide.

(0004) An attractive alternative process for producing synthesis gas is the autothermal reforming (ATR) process which uses oxidation to produce heat and a catalyst to permit reforming to occur at lower temperatures than the POx process. Similar to the POx process, oxygen is required to partially oxidize natural gas in a burner to provide heat, high temperature carbon dioxide and steam to reform the residual methane. Some steam needs to be added to the natural gas to control carbon formation on the catalyst. However, both the ATR and POx processes require separate air separation units (ASU) to produce high-pressure oxygen, which adds complexity as well as capital and operating costs to the overall process.

(0005) When the feedstock contains significant amounts of heavy hydrocarbons, SMR and ATR processes are typically preceded by a pre-reforming step. Pre-reforming is a catalyst based process for converting higher hydrocarbons to methane, hydrogen, carbon monoxide and carbon dioxide. The reactions involved in pre-reforming are generally endothermic. Most pre-reformers on natural gas streams operate in the endothermic area and operate adiabatically, and thus the pre-reformed feedstock leaves at a lower temperature than the feedstock entering the pre-reformer. Another process that will be discussed in this invention is the secondary reforming process, which is essentially an autothermal process that is fed the product from a steam methane reforming process. Thus, the feed to a secondary reforming process is primarily synthesis gas from steam methane reforming. Depending on the end application, some natural gas may bypass the SMR process and be directly introduced into the secondary reforming step. Also, when a SMR process is followed by a secondary reforming process, the SMR may operate at a lower temperature, e.g. 650°C to 825°C versus 850°C to 1000°C.

(0006) As can be appreciated, the conventional methods of producing a synthesis gas such as have been discussed above are expensive and require complex installations. To overcome the complexity and expense of such installations it has been proposed to

generate the synthesis gas within reactors that utilize an oxygen transport membrane to supply oxygen and thereby generate the heat necessary to support endothermic heating requirements of the steam methane reforming reactions. A typical oxygen transport membrane has a dense layer that, while being impervious to air or other oxygen containing gas, will transport oxygen ions when subjected to an elevated operational temperature and a difference in oxygen partial pressure across the membrane.

(0007) Examples of oxygen transport membrane based reforming systems used in the production of synthesis gas can be found in United States Patent Nos. 6,048,472; 6,110,979; 6,114,400; 6,296,686; 7,261,751; 8,262,755; and 8,419,827. There is an operational problem with all of these oxygen transport membrane based systems because such oxygen transport membranes need to operate at high temperatures of around 900 °C to 1100 °C. When hydrocarbons such as methane and higher order hydrocarbons are subjected to such high temperatures within the oxygen transport membrane, excessive carbon formation occurs, especially at high pressures and low steam to carbon ratios. The carbon formation problems are particularly severe in the above-identified prior art oxygen transport membrane based systems. A different approach to using an oxygen transport membrane based reforming system in the production of synthesis gas is disclosed in United States Patent No. 8,349,214 which provides an oxygen transport membrane based reforming system that uses hydrogen and carbon monoxide as part of the reactant gas feed to the oxygen transport membrane tubes and minimizes the hydrocarbon content of the feed entering the permeate side of the oxygen transport membrane tubes. Excess heat generated within the oxygen transport membrane tubes is transported mainly by radiation to the reforming tubes made of conventional materials. Use of high hydrogen and carbon monoxide in feed to the oxygen transport membrane tubes addresses many of the highlighted problems with the earlier oxygen transport membrane systems.

(0008) Other problems that arise with the prior art oxygen transport membrane based reforming systems are the cost of the oxygen transport membrane modules and the lower than desired durability, reliability and operating availability of such oxygen

transport membrane based reforming systems. These problems are the primary reasons that oxygen transport membranes based reforming systems have not been successfully commercialized. Advances in oxygen transport membrane materials have addressed problems associated with oxygen flux, membrane degradation and creep life, but there is much work left to be done to achieve commercially viable oxygen transport membrane based reforming systems from a cost standpoint as well as from an operating reliability and availability standpoint. Also for hydrogen production additional challenges remain. Compared to conventional steam methane reformers, the oxygen transport membrane reforming systems mentioned above produce a synthesis gas containing lower amounts of hydrogen and higher amounts of carbon monoxide (lower hydrogen to carbon monoxide molar ratio); treating this synthesis gas in a hydrogen PSA results in a tail gas having a higher flow and substantial fuel value.

(0009) The present invention addresses the aforementioned problems by providing an improved process for hydrogen production using a reactively-driven oxygen transport membrane based system, which comprises of two reactors that can be in the form of sets of catalyst containing tubes – reforming reactor and oxygen transport membrane reactor. Partial oxidation and some reforming occurs at the permeate (i.e. catalyst containing) side of the oxygen transport membranes and a reforming process facilitated by a reforming catalyst occurs in the reforming reactor in close proximity to the oxygen transport membrane reactor. The partial oxidation process, which is exothermic, and the reforming process, which is endothermic, both occur within the oxygen transport membrane based reforming system and thus have a high degree of thermal integration so that heat released in the oxidation process supplies the heat absorbed by the reforming process. Specifically, improvements to the reactively-driven oxygen transport membrane based system include: modifications to the reactively-driven oxygen transport membrane based system to carry out both a primary reforming process in a catalyst filled reforming reactor as well as a secondary reforming process within the catalyst containing oxygen transport membrane reactor, and thermal coupling of the reforming reactor with a source of auxiliary heat to balance the reforming duty between

the oxygen transport membrane reactor and the auxiliary heat source. Further improvements to obtain higher hydrogen recovery include subjecting the synthesis gas to water gas shift reactions in a high temperature or medium temperature shift reactor and optionally in a low temperature shift reactor.

Summary of the Invention

(00010) The present invention may be characterized as a method for producing hydrogen utilizing an oxygen transport membrane based reforming system, comprising at least two reactors that can be in the form of sets of catalyst containing tubes, including a reforming reactor and a reactively driven and catalyst containing oxygen transport membrane reactor. The method comprises: (i) reforming a hydrocarbon containing feed stream in a reforming reactor in the presence of a reforming catalyst disposed in the reforming reactor and heat to produce a reformed synthesis gas stream comprising hydrogen, carbon monoxide, and unreformed hydrocarbon gas; (ii) feeding the reformed synthesis gas stream to a reactant side of a reactively driven and catalyst containing oxygen transport membrane reactor, wherein the oxygen transport membrane reactor includes at least one oxygen transport membrane element configured to separate oxygen from an oxygen containing stream at the oxidant side of the reactively driven and catalyst containing oxygen transport membrane reactor and permeate separated oxygen to the reactant side through oxygen ion transport when subjected to an elevated operational temperature and a difference in oxygen partial pressure across the at least one oxygen transport membrane element; (iii) reacting a portion of the reformed synthesis gas stream with oxygen permeated through the at least one oxygen transport membrane element to produce the difference in oxygen partial pressure across the at least one oxygen transport membrane element and generate reaction products and heat, including a first portion of the heat required for the reforming of the hydrocarbon containing feed stream in the reforming reactor; (iv) reforming unreformed hydrocarbon gas in the reformed synthesis gas stream in the presence of catalysts contained in the oxygen transport membrane reactor, the reaction products and the heat to produce a

synthesis gas product stream; (v) treating at least a portion of synthesis gas product stream in a separate high temperature shift reactor to form a hydrogen-enriched synthesis gas stream; and (vi) recovering a hydrogen product stream and a tail gas stream from the hydrogen-enriched synthesis gas stream utilizing a hydrogen PSA; wherein a second portion of the heat required for the reforming of the hydrocarbon containing feed in the reforming reactor is transferred from an auxiliary heat source disposed proximate the reforming reactor. The heat generated as a result of the reaction of the reformed synthesis gas stream with permeated oxygen in the reactively driven and catalyst containing oxygen transport membrane reactor is transferred: (i) to the reformed synthesis gas stream present in the reactively driven, catalyst containing oxygen transport membrane reactor; (ii) to the reforming reactor; and (iii) to an oxygen depleted retentate stream. The auxiliary heat source generates heat for transfer to the reforming reactor utilizing one or more auxiliary oxygen transport membrane reactors wherein the auxiliary oxygen transport membrane reactor comprises a plurality of reactively driven oxygen transport membrane elements disposed proximate the reforming reactor and configured to: (i) separate oxygen from the oxygen containing stream contacting the oxidant side of the oxygen transport membrane element and permeate separated oxygen to the reactant side of the oxygen transport membrane element through oxygen ion transport; (ii) receive a hydrogen containing stream at the reactant side at a pressure of about 3 bar or less; and (iii) react the hydrogen containing stream with the permeated oxygen at the reactant side to produce the difference in oxygen partial pressure across the oxygen transport membrane element and to produce an auxiliary reaction product stream and heat. The auxiliary heat source can be configured to utilize all of a portion of the tail gas or a portion of the synthesis gas product or a light hydrocarbon containing gas or mixtures thereof. Alternately the auxiliary heat source can generate heat utilizing one or more ceramic burners disposed proximate the reforming reactor and the reactively driven and catalyst containing oxygen transport membrane reactor by combusting hydrogen, carbon monoxide, a light hydrocarbon containing gas or mixtures thereof using air or oxygen enriched air or

oxygen depleted retentate as the oxidant. The auxiliary heat source can also be configured to contain one or more auxiliary oxygen transport membrane reactors, as well as, one or more ceramic burners. Natural gas or any methane rich gas can be used as a source of the hydrocarbon containing feed stream. Sulfur containing species present in the source can be removed by desulfurization prior to feeding the hydrocarbon containing feed stream to the reforming reactor. For this purpose a portion of the hydrogen product stream can be utilized for desulfurization.

(00011) The invention may also be characterized as an oxygen transport membrane based hydrogen production system comprising: (a) an oxygen transport membrane based reactor housing containing: a reforming reactor disposed in the reactor unit and configured to reform a hydrocarbon containing feed stream in the presence of a reforming catalyst disposed in the reforming reactor and heat to produce a reformed synthesis gas stream; a reactively driven and catalyst containing oxygen transport membrane reactor disposed in the reactor housing proximate the reforming reactor and configured to receive the reformed synthesis gas stream and react a portion of the reformed synthesis gas stream with permeated oxygen and generate a first reaction product and heat, including a first portion of the heat required by the reforming reactor, wherein the reactively driven, catalyst containing oxygen transport membrane reactor is further configured to reform any unreformed hydrocarbon gas in the reformed synthesis gas stream in the presence of reforming catalyst, some of the heat and the first reaction product generated by the reaction of the reformed synthesis gas stream and permeated oxygen to produce a synthesis gas product stream ; and an auxiliary heat source disposed in the reactor housing proximate the reforming reactor and configured to supply a second portion of the heat required by the reforming reactor to produce the reformed synthesis gas stream; (b) a water gas shift reactor unit containing a high temperature water gas shift reactor; and (c) a hydrogen PSA unit. The auxiliary heat source comprises one or more auxiliary oxygen transport membrane reactors wherein the auxiliary oxygen transport membrane reactor contains a plurality of reactively driven oxygen transport membrane elements disposed proximate the reforming reactor

and configured to: (i) separate oxygen from the oxygen containing stream contacting the oxidant side of the oxygen transport membrane element and permeate separated oxygen to the reactant side of the oxygen transport membrane element through oxygen ion transport; (ii) receive a hydrogen containing stream at the reactant side at a pressure of about 3 bar or less; and (iii) react the hydrogen containing stream with the permeated oxygen at the reactant side to produce the difference in oxygen partial pressure across the oxygen transport membrane element and to produce an auxiliary reaction product stream and heat. The auxiliary heat source can be configured to utilize all or a portion of the tail gas or a portion of the synthesis gas product or a light hydrocarbon containing gas or mixtures thereof. Alternately the auxiliary heat source can be configured to contain one or more ceramic burners disposed proximate the reforming reactor and the reactively driven and catalyst containing oxygen transport membrane reactor to combust hydrogen, carbon monoxide, a light hydrocarbon containing gas or mixtures thereof using air or oxygen enriched air or oxygen depleted retentate as the oxidant. The auxiliary heat source can also be configured to contain one or more auxiliary oxygen transport membrane reactors, as well as, one or more ceramic burners.

(00012) The composition of the synthesis gas product stream depends on several factors including the steam to carbon ratio in the reforming reactor feed, temperatures at the exit of the reforming reactor and the reactively driven catalyst containing oxygen transport membrane reactor, and the heat transferred from the auxiliary heat source to facilitate endothermic reforming reactions in the reforming reactor. At a temperature of about 730 °C at the exit of the reforming reactor and a temperature of about 995 °C at the exit of the reactively driven and catalyst containing oxygen transport membrane reactor, the module of the synthesis gas product stream is from about 1.85 to about 2.15 or more and is dependent on the amount of heat supplied to the reforming reactor from the auxiliary heat source. More specifically, at the specified temperatures, the module of the synthesis gas product stream rises from a minimum of about 1.85 when the percentage of heat supplied to the reforming reactor from the auxiliary heat source is less than 15% to a maximum of about 2.15 when the percentage of heat supplied to the

reforming reactor from the auxiliary heat source is greater than about 85%. Put another way, at temperatures of about 730 °C and 995 °C at the exit of the reforming reactor and reactively driven and catalyst containing oxygen transport membrane reactor respectively, the module of the synthesis gas product stream will be from about 1.85 to about 2.00 when the second portion of heat supplied to the reforming reactor from the auxiliary heat source is 50% or less of the total required heat to be supplied to the reforming reactor and from about 2.00 to about 2.15 when the second portion of heat supplied to the reforming reactor from the auxiliary heat source is more than 50% of the total required heat to be supplied to the reforming reactor. As indicated above, the actual module of the synthesis gas product stream is also dependent on the reforming temperatures within the oxygen transport membrane based reforming system. For example, if the temperature at the exit of the reforming reactor is raised to a temperature of from about 800 °C to about 900 °C, the range of module for the synthesis gas product stream would be expected to increase to perhaps from about 1.90 to about 2.25 or more depending on the amount of heat supplied to the reforming reactor from the auxiliary heat source.

(00013) In addition to the variation of the module of the synthesis gas product stream based on the reforming duty split between the first portion of heat and the second portion of heat designed into the oxygen transport membrane based reforming system, the hydrogen to carbon monoxide ratio (H_2/CO) of the synthesis gas product stream ranges from about 2.95 to about 3.10 at a reforming temperature of about 730 °C and depending on the amount of heat supplied to the reforming reactor from the auxiliary heat source. The carbon monoxide to carbon dioxide ratio (CO/CO_2) of the synthesis gas product stream also varies from about 2.50 to about 3.30 at a reforming temperature of about 730 °C and depending on the reforming duty split between the first portion of heat and the second portion of heat.

(00014) The auxiliary heat source may be designed to provide from about 15% to about 85% of the heat required for the reforming of the hydrocarbon containing feed stream. The auxiliary heat source may be in the form of one or more auxiliary oxygen

transport membrane reactors or one or more ceramic burners disposed within the reactor housing and in close proximity to the reforming reactor.

(00015) The present invention may also be characterized as a method for producing hydrogen utilizing an oxygen transport membrane based reforming system, which may comprise at least two reactors that can be in the form of sets of catalyst containing tubes, including a reforming reactor and an oxygen transport membrane reactor, the method comprising the steps of: (i) reforming a hydrocarbon containing feed stream in a reforming reactor in the presence of a reforming catalyst disposed in the reforming reactor and heat to produce a reformed synthesis gas stream comprising hydrogen, carbon monoxide, and unreformed hydrocarbon gas; (ii) feeding the reformed synthesis gas stream to a reactant side of a reactively driven and catalyst containing oxygen transport membrane reactor, wherein the oxygen transport membrane reactor includes at least one oxygen transport membrane element configured to separate oxygen from an oxygen containing stream at the oxidant side of the reactively driven and catalyst containing oxygen transport membrane reactor to the reactant side through oxygen ion transport when subjected to an elevated operational temperature and a difference in oxygen partial pressure across the at least one oxygen transport membrane element; (iii) reacting a portion of the reformed synthesis gas stream with oxygen permeated through the at least one oxygen transport membrane element to produce the difference in oxygen partial pressure across the at least one oxygen transport membrane element and generate reaction products and heat, including the heat required for the reforming of the hydrocarbon containing feed stream in the reforming reactor; (iv) reforming unreformed hydrocarbon gas in the reformed synthesis gas stream in the presence of one or more catalysts contained in the oxygen transport membrane reactor, the reaction products and the heat to produce a synthesis gas product stream; (v) treating at least a portion of synthesis gas product stream in a separate high temperature shift reactor followed by a low-temperature shift reactor to form a hydrogen-enriched synthesis gas stream; and (vi) recovering a hydrogen product stream and a tail gas stream from the hydrogen-enriched synthesis gas stream utilizing a hydrogen PSA.

Natural gas or any methane rich gas can be used as a source of the hydrocarbon containing feed stream. Sulfur containing species present in the source can be removed by desulfurization prior to feeding the hydrocarbon containing feed stream to the reforming reactor. For this purpose a portion of the hydrogen product stream can be utilized for desulfurization.

(00016) The invention may also be characterized as an oxygen transport membrane based hydrogen production system comprising: (a) an oxygen transport membrane based reactor unit containing: a reforming reactor disposed in the reactor housing and configured to reform a hydrocarbon containing feed stream in the presence of a reforming catalyst disposed in the reforming reactor and heat to produce a reformed synthesis gas stream; a reactively driven oxygen transport membrane reactor disposed in the reactor housing proximate the reforming reactor and configured to receive the reformed synthesis gas stream and react a portion of the reformed synthesis gas stream with permeated oxygen and generate a first reaction product and heat, including the heat required by the reforming reactor wherein the reactively driven, catalyst containing oxygen transport membrane reactor is further configured to reform any unreformed hydrocarbon gas in the reformed synthesis gas stream in the presence of reforming catalyst, some of the heat and the first reaction product generated by the reaction of the reformed synthesis gas stream and permeated oxygen to produce a synthesis gas product stream; (b) a water gas shift reactor unit containing a high temperature water gas shift reactor followed by a low temperature water gas shift reactor; and (c) a hydrogen PSA unit.

(00017) The reactively driven oxygen transport membrane reactor is further configured to reform any unreformed hydrocarbon gas in the reformed synthesis gas stream in the presence of one or more catalysts and some of the heat generated by the reaction of the reformed synthesis gas stream and permeated oxygen to produce a synthesis gas product stream.

Brief Description of the Drawings

(00018) While the specification concludes with claims distinctly pointing out the subject matter that applicants regard as their invention, it is believed that the invention will be better understood when taken in connection with the accompanying drawings in which:

(00019) Fig. 1 is a schematic illustration of an embodiment of an oxygen transport membrane (OTM) based reforming system, designed to carry out both a primary reforming process and a secondary reforming process within the oxygen transport membrane reactor utilizing an auxiliary heat source comprising an auxiliary oxygen transport membrane reactor;

(00020) Fig. 2 is a schematic illustration of an embodiment of an oxygen transport membrane (OTM) based reforming system, designed to carry out both a primary reforming process and a secondary reforming process within the oxygen transport membrane reactor utilizing an auxiliary heat source comprising an auxiliary oxygen transport membrane reactor, tailored for hydrogen production utilizing a water gas shift reactor and H₂ PSA;

(00021) Fig. 3 is a schematic illustration of an alternate embodiment of an oxygen transport membrane (OTM) based reforming system, designed to carry out both a primary reforming process and a secondary reforming process within the oxygen transport membrane reactor, tailored for hydrogen production utilizing high temperature water gas shift reactor, low temperature water gas shift reactor, and a H₂ PSA;

(00022) Fig. 4 is a graph that depicts the module of the synthesis gas produced in the oxygen transport membrane (OTM) based reforming system as a function of the percent of primary reforming duty attributable to the auxiliary heat source;

(00023) Fig. 5 is a graph that depicts the hydrogen to carbon monoxide ratio (H₂/CO) of the synthesis gas produced in the oxygen transport membrane (OTM) based reforming system as a function of the percent of primary reforming duty attributable to the auxiliary heat source; and

(00024) Fig. 6 is a graph that depicts the carbon monoxide to carbon dioxide ratio (CO/CO₂) of the synthesis gas produced in the oxygen transport membrane (OTM) based reforming system as a function of the percent of primary reforming duty attributable to the auxiliary heat source.

Detailed Description

(00025) Fig. 1 provides a schematic illustration of an embodiment of an oxygen transport membrane based reforming system 100 in accordance with the present invention. As seen therein, an oxygen containing stream 110, such as air, is introduced to the system by means of a forced draft (FD) fan 114 into a heat exchanger 113 for purposes of preheating the oxygen containing feed stream 110. Heat exchanger 113 is preferably a high efficiency, cyclic and continuously rotating ceramic regenerator disposed in operative association with the oxygen containing feed stream 110 and a heated oxygen depleted retentate stream 124. The incoming air feed stream 110 is heated in the ceramic regenerator 113 to a temperature in the range of about 850 °C to 1050 °C to produce a heated air feed stream 115.

(00026) The oxygen depleted air leaves the oxygen transport membrane reforming tubes as heated oxygen depleted retentate stream 124 at the same or slightly higher temperature than the heated air feed stream 115. Any temperature increase, typically less than about 30 °C, is attributable to the portion of energy generated by oxidizing reaction of hydrogen and carbon monoxide in the oxygen transport membrane tubes and transferred by convection to the oxygen depleted retentate stream 124.

(00027) This oxygen depleted retentate stream 124 is heated back to a temperature of from about 1050 °C to about 1200 °C prior to being directed to the heat exchanger or ceramic regenerator 113. This increase in temperature of the oxygen depleted retentate stream 124 is preferably accomplished by use of a duct burner 126, which facilitates combustion of a fuel stream 128 using some of the residual oxygen in the retentate stream 124 as the oxidant. Though not shown, an alternative means is to combust the fuel stream 128 with a separate air stream in duct burner 126 and then mix

the hot flue gas with the oxygen depleted retentate stream 124. In the ceramic heat exchanger or regenerator 113, the heated, oxygen depleted retentate stream 124 provides the energy to raise the temperature of the incoming feed air stream 110 from ambient temperature to a temperature from about 850 °C to about 1050 °C. The resulting cold retentate stream exiting the ceramic heat exchanger, typically containing less than about 5% oxygen, leaves the oxygen transport membrane based reforming system 100 system as exhaust gas 131 at a temperature of around 150 °C.

(00028) Although not shown in Fig. 1, an alternate embodiment of the oxygen transport membrane based reforming system 100 could dispose the duct burner and fuel stream upstream of the reactors in intake duct 116. Such arrangement would allow use of a smaller regenerator 113, less severe operating conditions for the regenerator 113 and possibly enable the regenerator to be built with cheaper materials.

(00029) The hydrocarbon containing feed stream 130, preferably natural gas, to be reformed is typically mixed with a small amount of hydrogen or hydrogen-rich gas 132 to form a combined hydrocarbon feed 133 and then preheated to around 370 °C in heat exchanger 134 that serves as a feed preheater, as described in more detail below. Since natural gas typically contains unacceptably high level of sulfur species, the hydrogen or hydrogen-rich gas 132 is added to facilitate desulfurization. Preferably, the heated feed stream 136 undergoes a sulfur removal process via device 140 such as hydro-treating to reduce the sulfur species to H₂S, which is subsequently removed in a guard bed (not shown) using material like ZnO and/or CuO. The hydro-treating step also saturates any alkenes present in the hydrocarbon containing feed stream. Further, since natural gas generally contains higher hydrocarbons that will break down at high temperatures to form unwanted carbon deposits that adversely impact the reforming process, the natural gas feed stream is preferably pre-reformed in an adiabatic pre-reformer (not shown), which converts higher hydrocarbons to methane, hydrogen, carbon monoxide, and carbon dioxide. Also contemplated but not shown is an embodiment where the pre-reformer is a heated pre-reformer that may be thermally coupled with oxygen transport membrane based reforming system.

(00030) Superheated steam 150 is added to the pre-treated natural gas and hydrogen feed stream 141, as required, to produce a mixed feed stream 160 with a steam to carbon ratio from about 1.0 to about 2.5, and more preferably from about 1.2 to about 2.2. The superheated steam 150 is preferably at a pressure from about 15 bar to about 80 bar and at a temperature from about 300 °C to about 600 °C and generated in a fired heater 170 using a source of process steam 172. As seen in Fig. 1, the fired heater 170 is configured to combust a fuel stream 424 and a portion of the off-gas 229 produced by the oxygen transport membrane based reforming system using air 175 as the oxidant to heat the process steam 172 to superheated steam 150. In the illustrated embodiment, a source of air 175 is heated in the fired heater 170 to produce a heated air stream 176 to be used as the oxidant in the fired heater 170. The mixed feed stream 160 is also heated in the fired heater 170 producing a heated mixed feed stream 180. The heated mixed feed stream 180 has a temperature preferably from about 450 °C to about 650 °C and more preferably a temperature from about 500 °C to about 600 °C.

(00031) The illustrated embodiment of the oxygen transport membrane based reforming system 100 comprises three reactors (200, 210, 220) disposed in a single reactor housing 201. The first reactor is a reforming reactor 200 which comprises reforming catalyst containing tubes configured to reform the heated mixed feed stream 180 containing a hydrocarbon feed and steam in the presence of a conventional reforming catalyst disposed in the reforming tubes and heat to produce a reformed synthesis gas stream 205. The temperature of the reformed hydrogen-rich synthesis gas stream 205 is typically designed to be from about 650 °C to about 850 °C.

(00032) The reformed synthesis gas stream 205 is then fed as an influent to the second reactor which is an oxygen transport membrane reactor 210. More particularly, reformed synthesis gas stream 205 is fed to a reactant side of a reactively driven and catalyst containing oxygen transport membrane reactor 210. The reactively driven, oxygen transport membrane reactor 210 includes one or more oxygen transport membrane elements or tubes each having an oxidant side and a reactant side that are disposed proximate to the reforming tubes in reforming reactor 200. Each of the oxygen

transport membrane elements or tubes are configured to separate oxygen from the heated oxygen containing stream 115 contacting the oxidant side and permeate to the reactant side through oxygen ion transport. The oxygen ion transport occurs when the oxygen transport membrane elements or tubes are subjected to elevated operational temperatures and there is a difference in oxygen partial pressure across the oxygen transport membrane elements or tubes.

(00033) A portion of the reformed synthesis gas stream 205 fed to the reactant side of the oxygen transport membrane reactor 210 immediately reacts with oxygen permeated through the oxygen transport membrane elements or tubes to produce the difference in oxygen partial pressure across the oxygen transport membrane elements or tubes which drives the oxygen ion transport and separation. This reaction produces reaction products and heat. A portion of the heat produced by the reaction of the reformed synthesis gas stream 205 and the permeated oxygen is transferred via convection to the oxygen depleted retentate stream 124 and another portion of the heat is transferred via radiation to the reforming reactor 200.

(00034) The oxygen transport membrane reactor 210 is further configured to reform unreformed hydrocarbon gas in the reformed synthesis gas stream 205 and produce a synthesis gas product stream 215. This secondary reforming occurs in the presence of one or more reforming catalysts contained in the oxygen transport membrane elements or tubes, reaction products (e.g. from the reaction of a portion of the reformed synthesis gas stream 205 and oxygen permeate) and the third portion of the energy or heat produced by the same reaction. The synthesis gas product stream 215 leaving the oxygen transport membrane reactor 210 is preferably at a temperature from about 900 °C to about 1050 °C.

(00035) The third reactor in the illustrated embodiment is an auxiliary oxygen transport membrane reactor 220 that is configured to provide an auxiliary source of radiant heat to the reforming reactor 200. This auxiliary reactor 220 preferably provides from about 15% to about 85% of the heat required for the initial reforming of the heated mixed feed stream 180 that occurs in the reforming reactor 200. The auxiliary oxygen

transport membrane reactor 220 is also a reactively driven oxygen transport membrane reactor 220 that comprises a plurality of oxygen transport membrane elements or tubes disposed proximate to or in a juxtaposed orientation with respect to the reforming reactor 200. The auxiliary oxygen transport membrane reactor 220 is configured to also separate or permeate oxygen from the oxygen containing stream 115 contacting the oxidant side of the oxygen transport membrane elements or tubes to the reactant side of the oxygen transport membrane elements or tubes through oxygen ion transport. The permeated oxygen reacts with a hydrogen containing stream 222, preferably at a pressure less than about 3 bar, that is fed via a valve 221 to the reactant side of the oxygen transport membrane elements or tubes to produce the difference in oxygen partial pressure across the oxygen transport membrane element and to produce an auxiliary reaction product stream 225 and heat.

(00036) In the illustrated embodiment, the low pressure hydrogen containing stream 222 is a hydrogen and light hydrocarbon containing stream that preferably includes a recirculated portion 226 of the synthesis gas product stream and optionally a light hydrocarbon containing gas 224. A portion of the reaction product stream 225 exiting the reactant side of the oxygen transport membrane elements or tubes of the oxygen transport membrane reactor 220 is an off-gas 227 that may be mixed with a supplementary natural gas fuel 228 to the duct burner 126. Another portion of the reaction product stream 225 exiting the reactant side of the oxygen transport membrane elements or tubes is an off-gas 229 that may be mixed with a supplementary natural gas fuel 124 to fired heater 170.

(00037) Preferably, the reforming reactor 200 and the oxygen transport membrane reactor 210 are arranged as sets of closely packed tubes in close proximity to one another. The tubes in reforming reactor 200 generally contain reforming catalyst. Oxygen transport membrane reactor 210 as well as auxiliary oxygen transport membrane reactor 220 comprises a plurality of ceramic oxygen transport membrane tubes. The oxygen transport membrane tubes are preferably configured as multilayered ceramic tubes capable of conducting oxygen ions at an elevated operational temperature,

wherein the oxidant side of the oxygen transport membrane tubes is the exterior surface of the ceramic tubes exposed to the heated oxygen containing stream and the reactant side or permeate side is the interior surface of the ceramic tubes. Within each of the oxygen transport membrane tubes are one or more catalysts that facilitate partial oxidation and/or reforming, as applicable. Although only three of the reforming tubes are illustrated in Fig. 1 in close proximity to six of the secondary reforming oxygen transport membrane elements or tubes and four of the auxiliary oxygen transport membrane elements or tubes, there could be many of such oxygen transport membrane tubes and many reforming tubes in each oxygen transport membrane based reforming sub-system or assembly as would occur to those skilled in the art. Likewise, there could be multiple oxygen transport membrane based reforming sub-systems or assemblies used in industrial applications of the oxygen transport membrane based reforming system 100.

(00038) The oxygen transport membrane elements or tubes used in the embodiments disclosed herein preferably comprise a composite structure that incorporates a dense layer, a porous support and an intermediate porous layer located between the dense layer and the porous support. Each of the dense layer and the intermediate porous layer are capable of conducting oxygen ions and electrons at elevated operational temperatures to separate the oxygen from the incoming air stream. The porous support layer would thus form the reactant side or permeate side. The dense layer and the intermediate porous layer preferably comprise a mixture of an ionic conductive material and an electrically conductive material to conduct oxygen ions and electrons, respectively. The intermediate porous layer preferably has a lower permeability and a smaller average pore size than the porous support layer to distribute the oxygen separated by the dense layer towards the porous support layer. The preferred oxygen transport membrane tubes also include a mixed phase oxygen ion conducting dense ceramic separation layer comprising a mixture of a zirconia based oxygen ion conducting phase and a predominantly electronic conducting perovskite phase. This thin, dense separation layer is implemented on the thicker inert, porous support.

(00039) Oxidation catalyst particles or a solution containing precursors of the oxidation catalyst particles are optionally located in the intermediate porous layer and/or in the thicker inert, porous support adjacent to the intermediate porous layer. The oxidation catalyst particles contain an oxidation catalyst, such as gadolinium doped ceria, which are selected to promote oxidation of the partially reformed synthesis gas stream in the presence of the permeated oxygen when introduced into the pores of the porous support, on a side thereof opposite to the intermediate porous layer.

(00040) The endothermic heating requirements of the reforming process occurring in the reforming reactor 200 is supplied through radiation of some of the heat from the oxygen transport membrane reactor 210 and auxiliary oxygen transport membrane reactor 220 together with the convective heat transfer provided by heated oxygen depleted retentate stream. Sufficient thermal coupling or heat transfer between the heat-releasing ceramic oxygen transport membrane tubes and the heat-absorbing catalyst containing reformer tubes must be enabled within the design of the present reforming system. A portion of the heat transfer between the ceramic oxygen transport membrane tubes and the adjacent or juxtaposed reforming catalyst containing reformer tubes is through the radiation mode of heat transfer whereby surface area, surface view factor, surface emissivity, and non-linear temperature difference between the tubes (e.g., $T_{\text{otm}}^4 - T_{\text{reformer}}^4$), are critical elements to achieve the desired thermal coupling. Surface emissivity and temperatures are generally dictated by tube material and reaction requirements. The surface area and surface view factor are generally dictated by tube arrangement or configuration within each module and the entire reactor. While there are numerous tube arrangements or configurations that could meet the thermal coupling requirements between the oxygen transport membrane tubes and the reformer tubes, a key challenge is to achieve a relatively high production rate per unit volume which, in turn, depends on the amount of active oxygen transport membrane area contained within the unit volume. An additional challenge to achieving the optimum thermal coupling performance is to optimize the size of the ceramic oxygen transport membrane tubes and the catalyst containing reformer tubes, and more particular the effective surface area

ratio, $A_{\text{reformer}}/A_{\text{otm}}$, of the respective tubes. Of course, such performance optimization must be balanced against the manufacturability requirements, costs, as well as the reliability, maintainability, operating availability of the modules and reactor.

(00041) Advantageously, it has been found that the module of the synthesis gas product stream produced from the disclosed embodiments of the oxygen transport membrane (OTM) based reforming system varies depending on the reforming temperature and the amount of heat supplied to the reforming reactor from the auxiliary heat source. For example, as depicted in Fig. 4, the module of the synthesis gas product stream produced from the disclosed embodiments, when the temperature at the exit of the reforming reactor is about 730 °C and the temperature at the exit of the reactively driven and catalyst containing oxygen transport membrane reactor is about 995 °C, is from about 1.80 to about 2.15 or more and is a function of the amount of heat supplied to the reforming reactor from the auxiliary heat source presented as a percentage of total primary reforming duty that comes from the auxiliary heat source. Similarly, as seen in Fig. 5, at a reforming temperature of about 730 °C the hydrogen to carbon monoxide ratio (H_2/CO) of the synthesis gas product stream is maintained with a small band generally from about 2.90 to about 3.10 depending on the amount of heat supplied to the reforming reactor from the auxiliary heat source. Again, the amount of heat supplied to the reforming reactor from the auxiliary heat source is depicted in Fig. 5 as a percentage of total primary reforming duty that comes from the auxiliary heat source. Lastly, as seen in Fig. 6 and at a reforming temperature of about 730 °C, the carbon monoxide to carbon dioxide ratio (CO/CO_2) of the synthesis gas product stream ranges from about 2.50 to about 3.30 depending on the amount of heat supplied to the reforming reactor from the auxiliary heat source.

(00042) The actual module, H_2/CO ratio and CO/CO_2 ratio of the synthesis gas product (syngas) stream depends on several factors including the reforming temperatures realized within the oxygen transport membrane based reforming system. In addition, the H_2/CO ratio and CO/CO_2 ratio of the syngas generated by the oxygen transport membrane reforming system also depends on the steam to carbon ratio in the

mixed feed entering the reforming reactor. The graphs of Figs. 4-6 represent a temperature of about 730 °C at the exit of the reforming reactor and a steam to carbon ratio of about 1.5. If this temperature is raised to a temperature of from about 800 °C to about 900 °C, the range of module for the synthesis gas product stream would be expected to also increase, perhaps from about 1.90 to about 2.25 or more depending on the amount or percentage of reforming duty heat supplied to the reforming reactor from the auxiliary heat source. Increasing the temperature at the exit of the reactively driven and catalyst containing oxygen transport membrane reactor typically results in a decrease in the module of the synthesis gas. Increasing the steam to carbon ratio of the mixed feed to the reforming reactor will increase H₂/CO ratio and decrease CO/CO₂ ratio. The module is not expected to vary as significantly.

(00043) As indicated above, the auxiliary heat source is configured, or more preferably designed, to provide from about 15% to about 85% of the total heat required for the primary reforming of the hydrocarbon containing feed stream in the reforming reactor. The auxiliary heat source may be an auxiliary oxygen transport membrane reactor as shown in Fig. 1 or may comprise one or more ceramic burners, or combinations thereof. At the low end of the 15% to 85% range, the module of the synthesis gas product stream is around 1.90 whereas at the higher end of the range, the module of the synthesis gas product stream is from about 2.10 to about 2.15 or more. An alternative way to characterize the graph of Fig. 4 and the synthesis gas product produced by the presently disclosed oxygen transport membrane based reforming systems is that the module of the synthesis gas product stream is from about 1.85 to about 2.00 when the heat supplied from the auxiliary heat source to the reforming reactor is 50% or less of the total required heat to be supplied to the reforming reactor, and from about 2.00 to about 2.15 or more when the heat supplied to the reforming reactor from the auxiliary heat source is more than 50% of the total required heat to the reforming reactor. As indicated above, if the temperature at the exit of the reforming reactor is raised, one would expect a corresponding increase in module of the synthesis gas product to 2.25 or more depending on the amount of heat supplied to the reforming

reactor from the auxiliary heat source. Increasing the steam to carbon ratio of the mixed feed to the reforming reactor from about 1.5 to around 2.2 is expected to increase the H₂/CO ratio of the synthesis gas to about 3.5 and to decrease the CO/CO₂ ratio of the synthesis gas to about 2.2.

(00044) As a result, it is possible to design and/or tailor the present oxygen transport membrane based reforming system to produce a synthesis gas having the desired characteristics by simply adjusting or modifying the heat duty split between oxygen transport membrane reactor and the auxiliary heat source as well as the reforming temperature. The desired or targeted synthesis gas characteristics will depend of course on the application of the synthesis gas and other system variables, such as reforming temperatures, methane slip, reactor pressures, etc.

(00045) Turning again to Fig. 1, the synthesis gas stream 215 produced by the oxygen transport membrane reactor 210 generally contains hydrogen, carbon monoxide, unconverted methane, steam, carbon dioxide and other constituents. A significant portion of the sensible heat from the synthesis gas stream 215 can be recovered using a heat exchange section or recovery train 250. Heat exchange section 250 is designed to cool the produced synthesis gas stream 215 exiting the oxygen transport membrane reactor 210. In this illustrated embodiment, the heat exchange section 250 is also designed such that in cooling the synthesis gas stream 215, process steam 172 is generated, the combined hydrocarbon feed stream 133 is preheated, and boiler feed water 255 and feed water 259 are heated.

(00046) To minimize metal dusting issues, the hot synthesis gas product stream 215, preferably at a temperature from about 900 °C to about 1050 °C is cooled to a temperature of about 400 °C or less in a Process Gas (PG) Boiler 252. The initially cooled synthesis gas product stream 254 is then used to preheat the mixture of natural gas and hydrogen feed stream 133 in a feed preheater 134 and subsequently to preheat boiler feed water 255 in the economizer 256 and to heat the feed water stream 259 in feed water heater 258. In the illustrated embodiment, the boiler feed water stream 255 is preferably pumped using a feed water pump (not shown), heated in economizer 256 and

sent to steam drum 257 while the heated feed water stream is sent to a de-aerator (not shown) that provides boiler feed water 255. Synthesis gas leaving the feed water heater 258 is preferably around 150 °C. It is cooled down to about 40 °C using a fin-fan cooler 261 and a synthesis gas cooler 264 fed by cooling water 266. The cooled synthesis gas 270 then enters a knock-out drum 268 where water is removed from the bottoms as process condensate stream 271 which, although not shown, is recycled for use as feed water, and the cooled synthesis gas 272 is recovered overhead.

(00047) The final synthesis gas product 276 is obtained from the compression of the cooled synthesis gas stream 272 in a synthesis gas compressor 274. Prior to such compression, however, a portion of the cooled synthesis gas stream 226 may optionally be recirculated to the reactor housing to form all or part of the low pressure hydrogen containing stream 222. Depending on the operating pressures of the oxygen transport membrane based reforming system, pressure of the recovered synthesis gas is preferably in the range of about 10 bar and 35 bar and more preferably in the range of 12 bar and 30 bar. The module of the final synthesis gas product produced in the described embodiment is typically about 1.8 to 2.3.

(00048) Fig. 2 is a schematic illustration of the oxygen transport membrane based reforming system of Fig. 1 tailored for and integrated with a hydrogen production process. In many regards, this embodiment is similar to the embodiment of Fig. 1 and, for sake of brevity, the description of the common aspects of the two embodiments will not be repeated here, rather, the following discussion shall focus on the differences.

(00049) A significant portion of the sensible heat from the synthesis gas stream 215 can be recovered using a downstream heat recovery and hydrogen recovery section 400 which is designed to both cool the produced synthesis gas stream 215 exiting the oxygen transport membrane reactor 210 and produce a hydrogen product 500. In the embodiment of Fig. 2, the heat recovery and hydrogen recovery section 400 is also designed such that in cooling the synthesis gas stream 215, process steam 402 is generated, the combined hydrocarbon feed stream 403 is preheated, and boiler feed water 405 is also heated. As with the previously described embodiments, the hot synthesis gas product stream 215,

preferably at a temperature between about 900 °C and 1050 °C is cooled to a temperature of about 400 °C or less in a Process Gas (PG) Boiler 252. Steam 409 is added to the initially cooled synthesis gas product stream 254 which is then directed to a high temperature shift reactor 410 to generate additional hydrogen via the Water Gas Shift reaction:

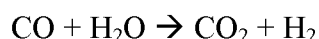

(00050) In the high temperature shift reactor 410, from about 20 to about 30% of the carbon monoxide is reacted to produce the hydrogen rich synthesis gas stream 412 containing from about 50 to about 60% molar hydrogen and having a H₂/CO ratio of from about 8 to about 20. Since the Water Gas Shift reaction is exothermic, the shifted synthesis gas stream 412 leaving the high temperature shift reactor 410 is at a temperature greater than the directly cooled synthesis gas product stream 254, and typically at a temperature of around 435°C. A portion of the sensible energy in this shifted synthesis gas 412 stream is then recovered by sequentially heating the natural gas and hydrogen feed stream 403 in a feed preheater 414 and then preheating boiler feed water stream 416 in economizer 418. In the illustrated embodiment, the boiler feed water stream 416 is preferably pumped using a feed water pump 417, heated in economizer 418 and sent to steam drum 424 while make-up water stream 425 and steam 411 are sent to a de-aerator 420 that provides the boiler feed water 405. Shifted synthesis gas leaving the economizer 418 is then cooled down to about 38 °C using a synthesis gas cooler 426 fed by a source of cooling water 428. The cooled synthesis gas 430 then enters a knock-out drum 432 used to remove moisture as a condensate stream 434 which is recycled for use as feed water, and the cooled shifted synthesis gas 440 is recovered overhead. Steam from steam drum 424 is: (i) used by the de-aerator 420; (ii) added to the pre-treated natural gas and hydrogen feed stream 141; and (iii) added to the initially cooled synthesis gas stream 254 upstream of the shift reactor 410. In small hydrogen production plants, such as shown in Fig.2, it may be preferable to design the plant for little to no steam export. However, when excess steam is required or desirable in larger hydrogen production plants, such steam can be made available by adding steam

generation capabilities into a separate fired heater, similar to the fired heater arrangement in Fig. 1.

(00051) The cooled shifted synthesis gas stream 440 is then directed to a hydrogen pressure swing adsorption (H₂ PSA) unit 450 which produces a hydrogen gas stream 452 and a tail gas 454, which contains about 30% hydrogen, about 50% carbon dioxide and from about 10 to about 20% carbon monoxide and trace amounts of unreacted methane (<1%). A portion of the hydrogen gas becomes the hydrogen product 500 and the rest of the hydrogen gas 452B is directed to a hydrogen recycle compressor 453 and mixed with the natural gas feed 130 prior to desulfurization and reforming to produce the combined hydrocarbon feed stream 403. Depending on the operating pressures of the oxygen transport membrane based reforming system, pressure of the hydrogen product is preferably in the range of about 10 bar and 35 bar and more preferably in the range of 12 bar and 30 bar. A portion or all of the tail gas 454 is directed to the auxiliary oxygen transport membrane reactor 220 and mixed with a light hydrocarbon containing gas 224 to form part or all of the hydrogen containing stream 222. During startup or even during regular operation, it is conceivable that instead of tail gas, a portion of the product syngas (hot or cooled) could be used to form part or all of the hydrogen containing stream 222. Optionally, all or a portion of the tail gas 454 could constitute all or a portion of the fuel stream 128 feeding the duct burner 126.

(00052) Another difference between the embodiment of Fig. 1 and the embodiment shown in Fig. 2 relates to the steam handling and heating of the mixed feed stream 160. As indicated above, a portion of the steam 411 from steam drum 424 is used by the de-aerator 420 while a second portion of the steam 409 is added to the initially cooled synthesis gas stream 254 upstream of the shift reactor 410. Yet another portion of the steam 413 may be added to the pre-treated natural gas and hydrogen feed stream which is then heated to a temperature preferably from about 475°C to about 650°C, and more preferably to a temperature from about 520°C to about 600°C by means of indirect heat exchange with the heated oxygen depleted retentate stream using steam coils 475 disposed in the retentate

duct 125 of the oxygen transport membrane based reforming system downstream of the reactor housing.

(00053) An alternate embodiment is shown in Fig 3. In many regards, this embodiment is similar to the embodiment of Fig. 2 and thus the description of the common aspects of the two will not be repeated here. The embodiment in Fig. 3 differs to the ones shown in Figs.1 and 2 because it lacks the auxiliary heat source 220 in the oxygen transport membrane based reforming system 100. As shown in Fig. 3, this embodiment comprises only reforming reactor 200 and oxygen transport membrane reactor 210. All the reforming duty required to produce the synthesis gas in reforming reactor 200 is provided by radiation of the heat generated in the oxygen transport membrane reactor 210. Because of the absence of the auxiliary oxygen transport membrane reactor 220, there is no need for fuel streams 222 and 224. Instead, the tail gas 454 is used directly as part of fuel stream 128 for the duct burner 126.

(00054) Another difference between the embodiments shown in Figs. 2 and 3 is the addition of a low temperature shift reactor 462 in Fig. 3. This low temperature shift reactor 462 is added to the system to increase the conversion of carbon monoxide and produce more hydrogen, therefore reducing the amount of tail gas 454 and increasing the conversion efficiency (*i.e.* BTU of NG (hydrocarbon feed) per SCF of hydrogen produced) of the system. The addition of the low temperature shift reactor 462 improves the efficiency (BTU/SCF of hydrogen produced) by up to about 25%. In the embodiment shown in Fig. 3, the cooled synthesis gas 460 enters the low temperature shift reactor 462 at about 160°C where most of the remaining carbon monoxide, typically greater than 80% and preferably greater than 95% is reacted with water to produce more hydrogen and carbon dioxide, resulting in a synthesis gas stream 464 with a H₂/CO ratio higher than about 370 and less than 1% molar of carbon monoxide. The synthesis gas stream 464 leaves the low temperature shift reactor 462 at about 190°C and is then cooled down to about 38°C using a synthesis gas cooler 466 fed by a source of cooling water 468. The cooled shifted synthesis gas stream 430 then enters a knock-out drum 432 used to remove moisture as condensate stream 434 which is recycled for use as feed water, and the cooled

shifted synthesis gas 320 is recovered overhead and sent to the H₂ PSA 450. Because of the addition of the low temperature shift reactor 462, the tail gas 454 composition is different from the previous embodiment, containing up to about 70% carbon dioxide and only trace amounts of carbon monoxide and methane (<1%).

(00055) The embodiments shown in Figs. 2 and 3 were simulated. Table 1 lists the hydrogen, carbon monoxide, carbon dioxide and methane content in the synthesis gas product 215 assuming the mixed feed 180 to have a steam to carbon ratio of 1.5. The Fig. 2 embodiment makes a synthesis gas product 215 having hydrogen to carbon monoxide ratio of 3.1; hydrogen is produced by further treating this synthesis gas in a separate high temperature water gas shift reactor followed by hydrogen PSA. The resulting tail gas from the hydrogen PSA has a lower heating value of about 156 Btu/Scf. The Fig. 3 embodiment that does not utilize an auxiliary heat source to support reforming reactions in the reforming reactor 200 makes a synthesis gas product 215 having hydrogen to carbon monoxide ratio of about 2.9, lower than that of Fig 2 embodiment. However, Fig. 3 employs both a high temperature water gas shift reactor and a low temperature water shift reactor to increase the hydrogen content in the feed to the hydrogen PSA and the resulting tail gas has a lower heating value of only about 84 Btu/Scf.

Table 1. Comparison of Typical Synthesis Gas and Tail Gas Stream Composition

Fig.	2			3			
	215	412	454	215	412	464	454
Molar Composition							
Hydrogen	51.76%	54.87%	35.69%	46.12%	49.33%	51.71%	28.51%
Carbon Monoxide	16.67%	3.88%	12.61%	15.92%	2.49%	0.11565%	0.43%
Carbon Dioxide	5.14%	14.84%	48.17%	6.39%	16.14%	18.52%	68.02%
Methane	0.72%	0.62%	2.00%	0.15%	0.13%	0.13%	0.47%
H₂/CO	3.1	14.1		2.9	19.8	447.1	
Lower Heating Value (BTU/SCF)			156				84

(00056) It is recognized that the embodiments presented in Figures 2 and 3 can also be used to co-produce syngas and hydrogen. In this case, only the portion of synthesis gas for hydrogen production is subject to water gas shift reactions at high and optionally low temperatures. This shifted syngas is sent to a H₂ PSA unit which produces a hydrogen gas product and a tail gas. The rest of the synthesis gas product is cooled and conditioned for subsequent use in end applications including synthesis of chemicals and liquid fuels.

(00057) While the present invention has been characterized in various ways and described in relation to preferred embodiments, as will occur to those skilled in the art, numerous, additions, changes and modifications thereto can be made without departing from the spirit and scope of the present invention as set forth in the appended claims.

Claims

What is claimed is:

1. A method for hydrogen production utilizing an oxygen transport membrane based reforming system, the method comprising the steps of:

reforming a hydrocarbon containing feed stream in a reforming reactor in the presence of a reforming catalyst disposed in the reforming reactor and heat to produce a reformed synthesis gas stream comprising hydrogen, carbon monoxide, and unreformed hydrocarbon gas;

feeding the reformed synthesis gas stream to a reactant side of a reactively driven and catalyst containing oxygen transport membrane reactor, wherein the oxygen transport membrane reactor includes at least one oxygen transport membrane element configured to separate oxygen from an oxygen containing stream at the oxidant side of the reactively driven and catalyst containing oxygen transport membrane reactor and permeate separated oxygen to the reactant side through oxygen ion transport when subjected to an elevated operational temperature and a difference in oxygen partial pressure across the at least one oxygen transport membrane element;

reacting a portion of the reformed synthesis gas stream with oxygen permeated through the at least one oxygen transport membrane element to produce the difference in oxygen partial pressure across the at least one oxygen transport membrane element and generate reaction products and heat, including a first portion of the heat required for the reforming of the hydrocarbon containing feed stream in the reforming reactor;

reforming unreformed hydrocarbon gas in the reformed synthesis gas stream in the presence of one or more catalysts contained in the oxygen transport membrane reactor, the reaction products and the heat to produce a synthesis gas product stream;

treating at least a portion of the synthesis gas product stream in a separate high temperature shift reactor to form a hydrogen-enriched synthesis gas stream; and

treating the hydrogen-enriched synthesis gas stream in a hydrogen PSA and recovering a hydrogen product stream and a tail gas stream;

wherein a second portion of the heat required for the reforming of the hydrocarbon containing feed in the reforming reactor is transferred from an auxiliary heat source disposed proximate to the reforming reactor, wherein the auxiliary heat source provides from about 15% to about 85% of the heat required for the reforming of the hydrocarbon containing feed stream in the reforming reactor.

2. The method of claim 1, wherein the heat generated as a result of the reaction of the reformed synthesis gas stream with permeated oxygen is transferred: (i) to the reformed synthesis gas stream present in the reactively driven, catalyst containing oxygen transport membrane reactor; (ii) to the reforming reactor; and (iii) to an oxygen depleted retentate stream.
3. The method of claim 1, wherein the auxiliary heat source comprises one or more auxiliary oxygen transport membrane reactors wherein the auxiliary oxygen transport membrane reactor comprises a plurality of reactively driven oxygen transport membrane elements disposed proximate the reforming reactor and configured to: (i) separate oxygen from the oxygen containing stream contacting the oxidant side of the oxygen transport membrane element and permeate separated oxygen to the reactant side of the oxygen transport membrane element through oxygen ion transport; (ii) receive a hydrogen containing stream at the reactant side at a pressure of about 3 bar or less; and (iii) react the hydrogen containing stream with the permeated oxygen at the reactant side to produce the difference in oxygen partial pressure across the oxygen transport membrane element and to produce an auxiliary reaction product stream and heat.
4. The method of claim 1, wherein the auxiliary heat source utilizes all of a portion of the tail gas or a portion of the synthesis gas product or a light hydrocarbon containing gas or mixtures thereof.
5. The method of claim 1, further comprising the step of reheating the oxygen depleted stream to a temperature of from about 1050°C to about 1200°C using a duct burner disposed within or proximate to the oxygen transport membrane based reforming system, where the duct burner is configured to combust a fuel stream to heat the incoming oxygen containing stream via indirect heat exchange.
6. The method of claim 1, wherein the auxiliary heat source is one or more ceramic burners disposed proximate the reforming reactor and the reactively driven and catalyst containing oxygen transport membrane reactor, the one or more ceramic burners configured to burn a light hydrocarbon containing gas using air or enriched air as the oxidant.

7. The method of claim 1, wherein the hydrogen to carbon monoxide ratio (H_2/CO) of the synthesis gas product stream is greater than 2.8 and is dependent on the reforming temperature and the amount of heat supplied to the reforming reactor from the auxiliary heat source.

8. A hydrogen production system comprising:

an oxygen transport membrane based reactor housing comprising:

a reforming reactor disposed in the reactor housing and configured to reform a hydrocarbon containing feed stream in the presence of a reforming catalyst disposed in the reforming reactor and heat to produce a reformed synthesis gas stream;

a reactively driven, catalyst containing oxygen transport membrane reactor disposed in the reactor housing proximate the reforming reactor and configured to receive the reformed synthesis gas stream and react a portion of the reformed synthesis gas stream with permeated oxygen and generate a first reaction product and heat, including a first portion of the heat required by the reforming reactor;

wherein the reactively driven, catalyst containing oxygen transport membrane reactor is further configured to reform any unreformed hydrocarbon gas in the reformed synthesis gas stream in the presence of reforming catalyst, some of the heat and the first reaction product generated by the reaction of the reformed synthesis gas stream and permeated oxygen to produce a synthesis gas product stream; and

an auxiliary heat source disposed in the reactor housing proximate the reforming reactor and configured to supply a second portion of the heat required by the reforming reactor to produce the reformed synthesis gas stream, wherein the auxiliary heat source provides from about 15% to about 85% of the heat required for the reforming of the hydrocarbon containing feed stream in the reforming reactor;

the oxygen transport membrane based hydrogen production system further comprising:

a water gas shift reactor unit; and

a hydrogen PSA unit.

9. The system of claim 8, wherein the reactively driven, catalyst containing oxygen transport membrane reactor further comprises a plurality of reforming catalyst containing oxygen transport

membrane tubes defining an oxidant side and a reactant side and configured to separate oxygen from an oxygen containing stream contacting the oxidant side and permeate separated oxygen to the reactant side through oxygen ion transport when subjected to the elevated operational temperature and the difference in oxygen partial pressure across the at least one oxygen transport membrane tube.

10. The system of claim 8, wherein the hydrogen to carbon monoxide ratio (H_2/CO) of the synthesis gas product stream is greater than 2.8 and is dependent on the reforming temperature and the amount of heat supplied to the reforming reactor from the auxiliary heat source.

11. The system of claim 8, wherein the auxiliary heat source comprises one or more auxiliary oxygen transport membrane reactors.

12. The system of claim 8, wherein the auxiliary heat source comprises one or more ceramic burners configured to burn a light hydrocarbon containing stream using air or enriched air as the oxidant.

13. A method for hydrogen production utilizing an oxygen transport membrane based reforming system, the method comprising the steps of:

reforming a hydrocarbon containing feed stream in a reforming reactor in the presence of a reforming catalyst disposed in the reforming reactor and heat to produce a reformed synthesis gas stream comprising hydrogen, carbon monoxide, and unreformed hydrocarbon gas;

feeding the reformed synthesis gas stream to a reactant side of a reactively driven and catalyst containing oxygen transport membrane reactor, wherein the oxygen transport membrane reactor includes at least one oxygen transport membrane element configured to separate oxygen from an oxygen containing stream at the oxidant side of the reactively driven and catalyst containing oxygen transport membrane reactor and permeate separated oxygen to the reactant side through oxygen ion transport when subjected to an elevated operational temperature and a difference in oxygen partial pressure across the at least one oxygen transport membrane element;

reacting a portion of the reformed synthesis gas stream with oxygen permeated through the at least one oxygen transport membrane element to produce the difference in oxygen partial

pressure across the at least one oxygen transport membrane element and generate reaction products and heat, including the heat required for the reforming of the hydrocarbon containing feed stream in the reforming reactor;

reforming unreformed hydrocarbon gas in the reformed synthesis gas stream in the presence of one or more catalysts contained in the oxygen transport membrane reactor, the reaction products and the heat to produce a synthesis gas product stream;

treating at least a portion of the synthesis gas product stream in a separate high temperature shift reactor followed by a low temperature shift reactor to form a hydrogen-rich synthesis gas stream; and

treating the hydrogen-rich synthesis gas stream in a hydrogen PSA and recovering a hydrogen product stream and a tail gas stream.

14. The method of claim 13, wherein the reactively driven oxygen transport membrane reactor further comprises a plurality of reforming catalyst containing oxygen transport membrane tubes defining an oxidant side and a reactant side and configured to separate oxygen from an oxygen containing stream contacting the oxidant side to the reactant side through oxygen ion transport when subjected to the elevated operational temperature and the difference in oxygen partial pressure across the at least one oxygen transport membrane tube.

15. The method of claim 13, wherein the hydrogen to carbon monoxide ratio (H_2/CO) of the synthesis gas product stream is from about 2.5 to about 3.5.

16. The method of claim 13, wherein the tail gas stream has a lower heating value of less than 100 Btu/Scf.

680720.1

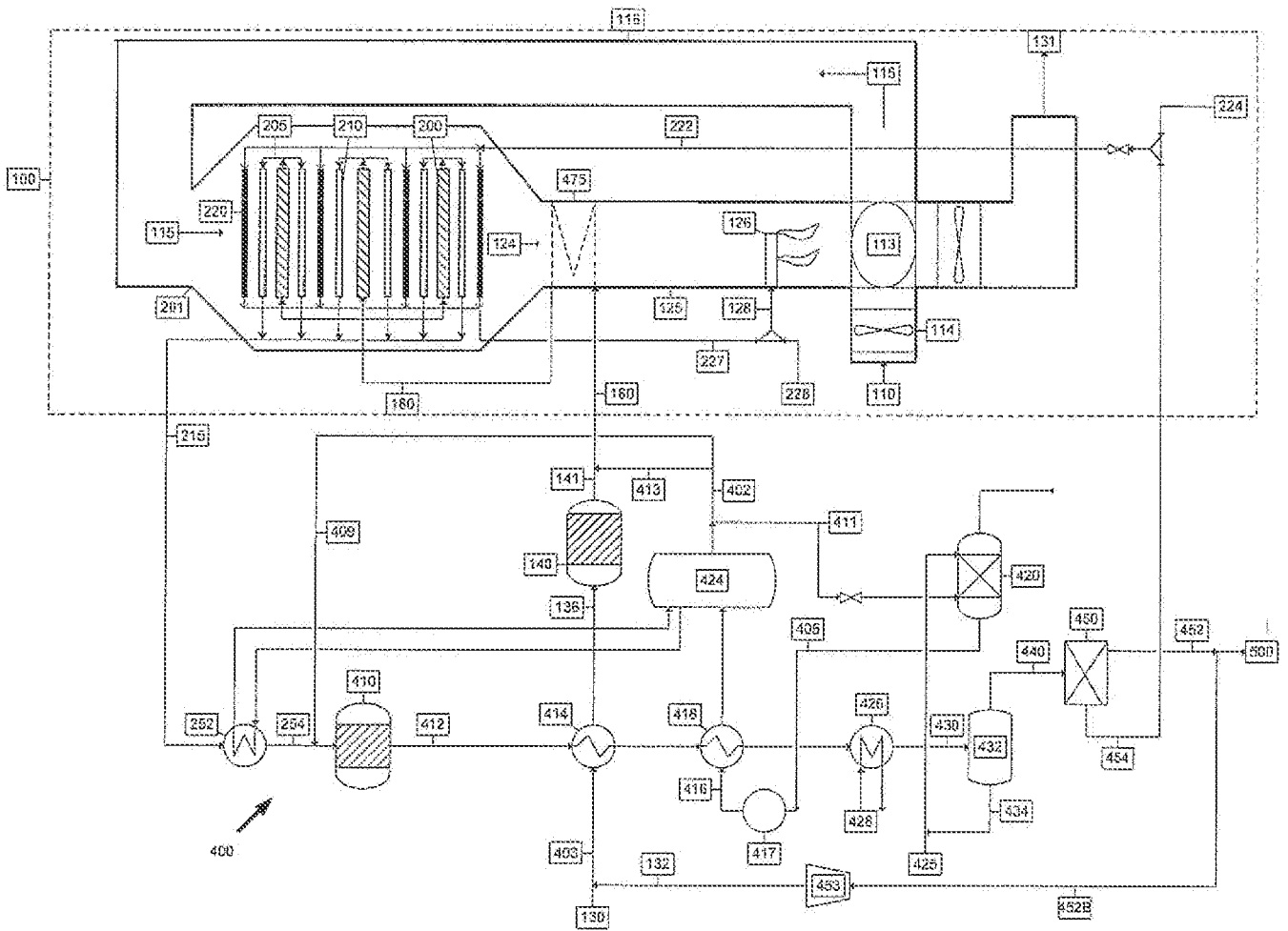

FIG. 2

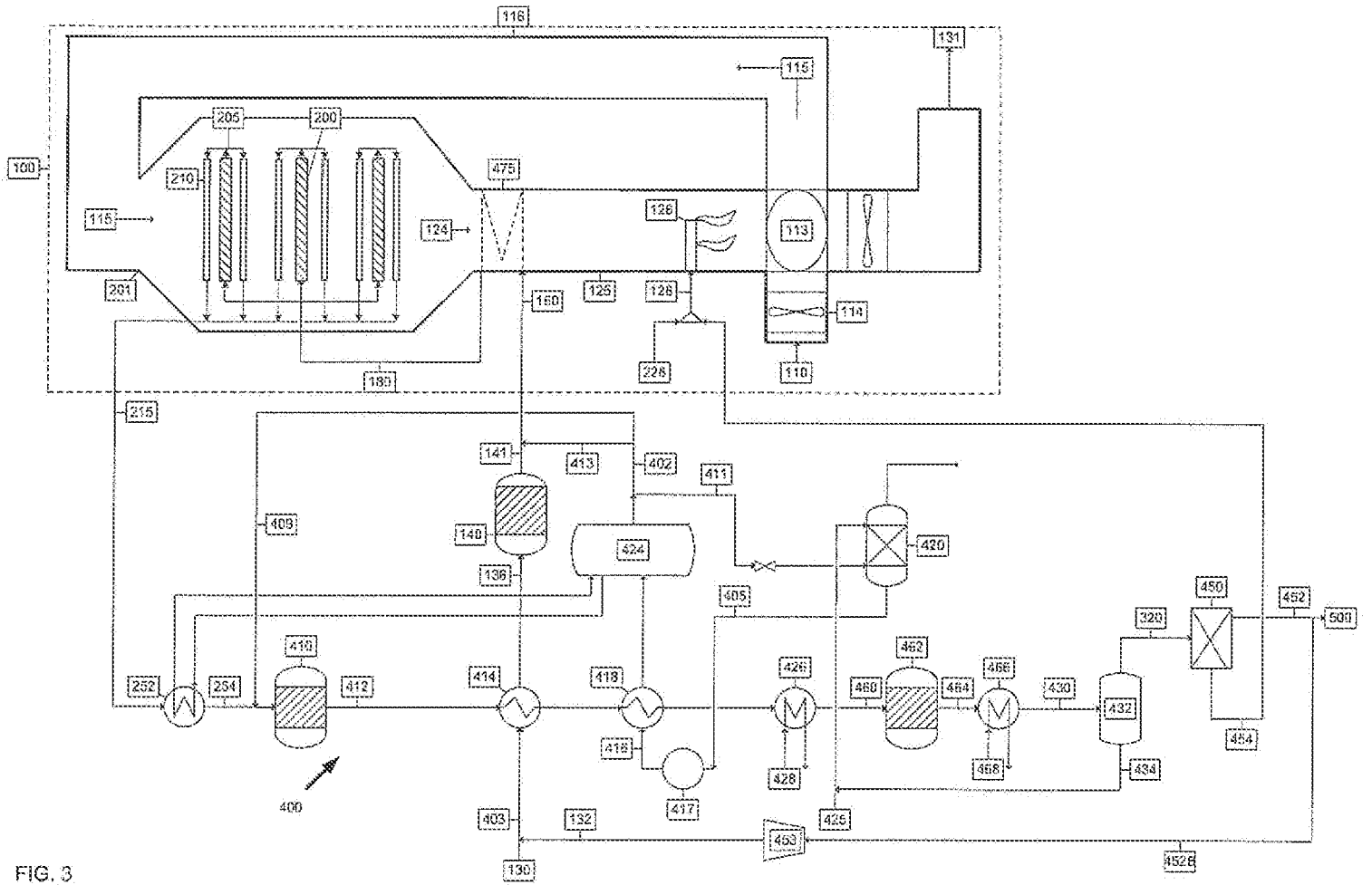
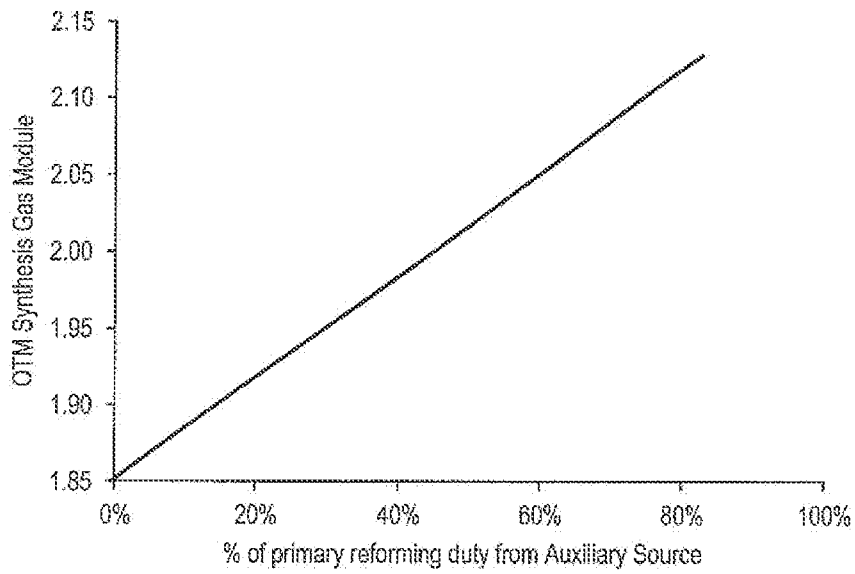
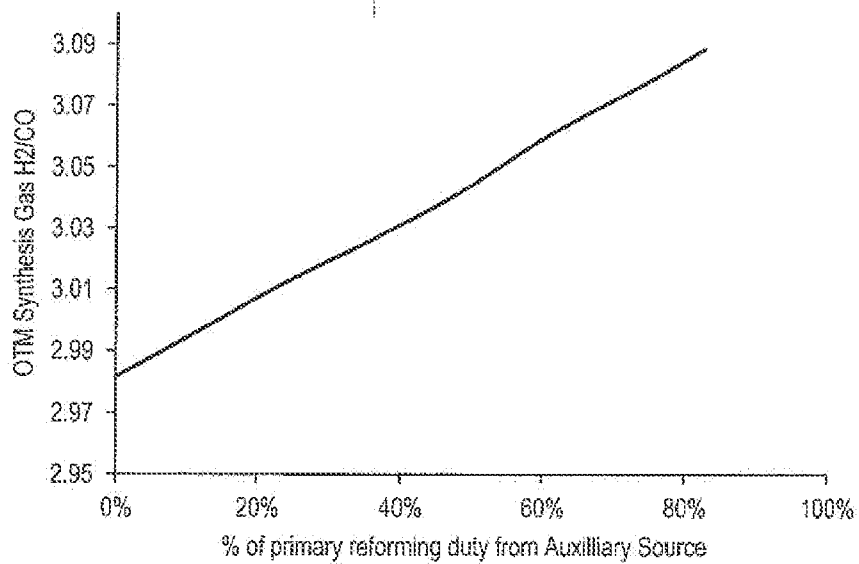

FIG. 3

4/5

**FIG. 4****FIG. 5**

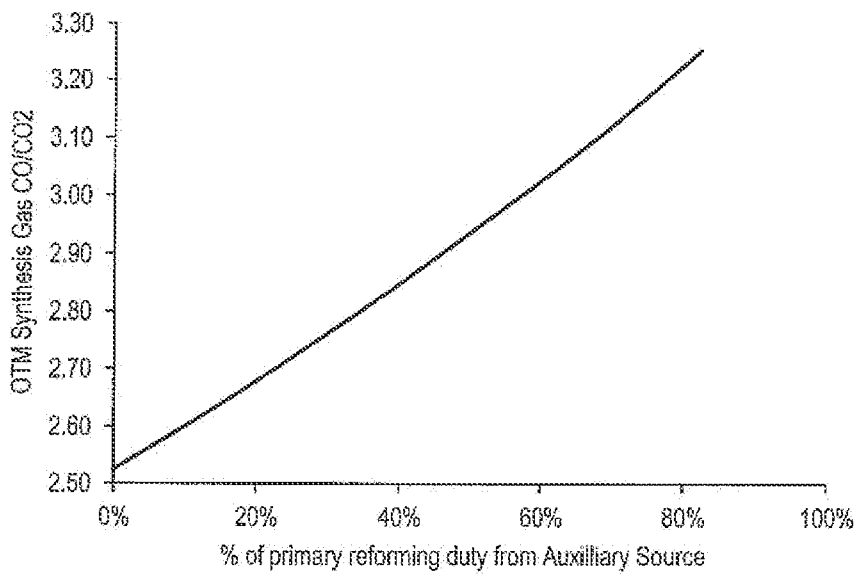

FIG. 6

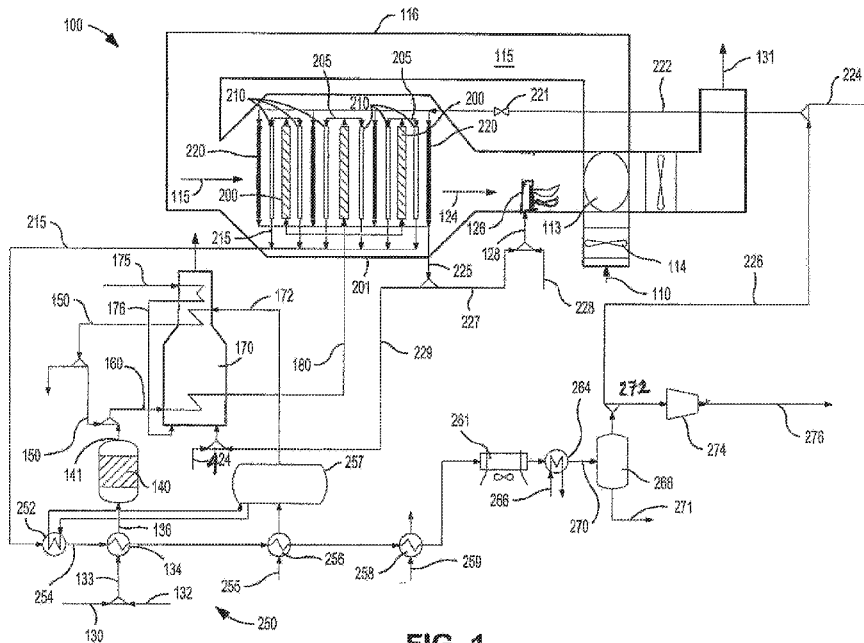

FIG. 1