



(11) **EP 1 726 773 B1**

(12) **EUROPEAN PATENT SPECIFICATION**

(45) Date of publication and mention of the grant of the patent:
19.06.2013 Bulletin 2013/25

(51) Int Cl.:
E06C 5/04 (2006.01) B66F 11/04 (2006.01)

(21) Application number: **06114454.9**

(22) Date of filing: **24.05.2006**

(54) **Turntable ladder for rescue vehicles**

Drehleiter für Einsatzfahrzeuge

Echelle tournante pour véhicules de secours

(84) Designated Contracting States:
AT BE BG CH CY CZ DE DK EE ES FI FR GB GR HU IE IS IT LI LT LU LV MC NL PL PT RO SE SI SK TR

(30) Priority: **25.05.2005 DE 102005024585**

(43) Date of publication of application:
29.11.2006 Bulletin 2006/48

(73) Proprietor: **IVECO MAGIRUS AG**
D-89079 Ulm (DE)

(72) Inventors:
• **Keller, Paul**
89601, SCHELKLINGEN (DE)

• **Hoersch, Heiner**
89129, LANGENAU (DE)

(74) Representative: **Borsano, Corrado**
Notarbartolo & Gervasi S.p.A.
Corso di Porta Vittoria, 9
20122 Milano (IT)

(56) References cited:
EP-A- 0 012 602 DE-C- 3 326 673
DE-U- 9 416 367 FR-A- 2 379 693
FR-A- 2 465 867 US-A- 5 437 345

EP 1 726 773 B1

Note: Within nine months of the publication of the mention of the grant of the European patent in the European Patent Bulletin, any person may give notice to the European Patent Office of opposition to that patent, in accordance with the Implementing Regulations. Notice of opposition shall not be deemed to have been filed until the opposition fee has been paid. (Art. 99(1) European Patent Convention).

Description

[0001] The invention concerns a turntable ladder for rescue vehicles with a number of telescopically extendable ladder elements, on the last of which a hinged arm, formed as a ladder element, is pivot-mounted about a horizontal axis.

[0002] A turntable of this type is known from the applicant's utility model DE 94 16 367 U1.

[0003] Hoist rescue vehicles are vehicles which are used above all for rescuing people in emergencies but also for providing technical assistance and for fire-fighting. The present invention applies to a turntable ladder for hoist vehicles of this type.

[0004] Turntable ladders are generally mounted on hoist vehicles on a bogie which allows rotation about a vertical axis. Further, they can be rotated about a horizontal axis with respect to the bogie and, finally, turntable ladders are generally formed out of telescopically extendable ladder elements, permitting the performing of operations at various heights. In this way, a relatively large range of targets can be reached to which either the ladder itself or a rescue cage attached to its end can be brought close. A disadvantage of ladders of this type exists in that they can only approach those points which are accessible in a straight line from the base of the ladder.

[0005] Rescue operations, however, often take place in narrow streets between buildings of various heights. In these cases, it is not always possible for the upper end of the ladder or the rescue cage to be brought close to the designated window sill or balcony parapet. The utility model mentioned suggests, therefore, mounting a collapsible hinged arm, pivoted about a horizontal axis, to the upper end of the ladder, in particular to the end of the last telescopically extendable ladder element, which can be placed over balcony parapets, edges of flat roofs etc.

[0006] In this way, in particular, overhanging walls, balustrades, edges of roofs and similar parts of buildings, but also cables, electric advertising etc. can be surmounted.

[0007] Telescopic boom platforms and articulated boom platforms are known which have an outer boom section carrying a rescue or work cage and which can be folded down with respect to the last boom section. With these types of construction, only the platform itself is usable for rescue tasks, whereas, on the other hand, it cannot be used as a ladder. Here the accessibility up to the extreme end or to the cage, as available with a ladder, is absent. Examples of the state of the art of this type are shown in the German unexamined and published applications DE 2348164 A and DE 2652244 A, the German patent specification DE 4221673 C and the European patent applications EP 217294 A and EP 522 315 A. Furthermore, reference is again made to the utility model mentioned at the beginning.

[0008] The turntable ladder with outer hinged arm described in the applicant's utility model DE 94 16 367 U offers numerous advantages in overcoming the problems

mentioned. It is, however, still not sufficiently flexible for areas difficult to access, as well as the fact that a close approach to particular positions by the end of the ladder or rescue cage requires a complex steering manoeuvre of the entire ladder.

[0009] The document DE 9416367 U describes a turntable ladder having all the features of the preamble of claim 1.

[0010] The underlying objective of the invention is to produce a turntable ladder of the type mentioned at the beginning which offers additional possibilities with respect to access to positions difficult to reach.

[0011] This objective is achieved by a turntable ladder according to claim 1.

The hinged arm has a lower member, fitted with rungs and usable as a ladder, and an upper member, serving as a railing. In the broadest sense, this results in a U-shaped cross-section.

[0012] The hinged arm consists of a base section, pivot-mounted to the end of the last ladder element, and, with respect to this, a telescopically displaceable end section, which can carry, in particular, a rescue cage.

[0013] The base section is pivot-mounted in a horizontal axis to the adjacent ladder element. The rotation follows, for example, with the help of hydraulic cylinders which are housed in a side assembly of the ladder, adjoining the axis of rotation.

[0014] All control, and other connections, are preferably relocated to the end section of the hinged arm and are accessible here or from the rescue cage. This applies, for example, to electrical sockets, fuse switches, water supplies, control switches.

[0015] Furthermore, support brackets are provided for climbing over from the end section to the rescue cage.

[0016] The end section is displaceable with respect to the base section of the hinged arm, preferably with the help of hydraulic cylinders housed in the lower member or in an appropriate way between lower and upper members.

[0017] The transfer of water for fire-fighting ensues with the help of a telescopically retractable water pipe. The electrical supply and all necessary data and control signals are transferred preferably via a drag chain.

[0018] The following explain in more detail, with the aid of the attached drawings, preferred examples of embodiments of the invention.

Fig. 1 shows in full a side view of the operational vehicle according to the invention;

Fig. 2 is a perspective view of the extreme end region of a turntable ladder with telescopically extended hinged arm;

Fig. 3 is a perspective view of the hinged arm in the extended position;

Fig. 4 is, correspondingly, a perspective view of the

hinged arm in the retracted position; and

Fig. 5 is a top view of the end region of the turntable ladder corresponding to Fig. 2.

[0019] The following description of examples of embodiment apply primarily to the extended hinged arm. For a more exact description of the basic rescue vehicle 10, the turntable ladder 12 and the hinged arm 14, as well as the rescue cage 16, the mentioned utility model 94 16 367 can additionally be referred to. The hinged arm 14 is located in the view shown in Fig. 1 in a position which rectilinearly extends the rest of the ladder. Obviously, the hinged arm can also be used in this position. In this elongated position, the hydraulic cylinders 18, which can be extended in order to lower the hinged arm, are shown in the retracted position. The rescue cage 16 has been folded down into the horizontal position in order to reduce the overall length and height. The best conditions for the total length of the vehicle and the driver's view from the driver's cabin (not shown) of the rescue vehicle 10 result in the position shown.

[0020] Fig. 2 shows the hydraulic cylinders 18 in the partially extended position. The hinged arm 14 is shown accordingly, lowered about a horizontal pivot 20 with respect to the rest of the turntable ladder. The hinged arm 14 comprises a base section 22 which has, in the construction customary for turntable ladders, lateral lower members 24, bridged by rungs 26, and upper members 28 which form a railing for the safety of rescue personnel. For reasons of stiffening, the upper and lower members are connected by means of cross members in a lattice arrangement. Details are known and do not have to be explained here.

[0021] In the construction described, the base section 22 has an essentially U-shaped cross-section. This applies for the extended end section 30, which likewise has a U-shaped cross-section with lower members 32, bridged by rungs 34, and upper members 36 which serve as a railing. The U-shaped cross-section of the end section 30 is somewhat smaller than that of the base section 22, so that the end section 30 can be slid inside the base section 22, as is customary for turntable ladders of this type. The displacement occurs with the help of a hydraulic cylinder (not shown) integrated in the structure of the base section 22. As mentioned, Fig. 2 shows the extended position of the end section 30.

[0022] One can identify that the rescue cage 16 is attached to the end of the end section by support arms 38,40. The support arms 38,40 are pivot-connected with the rescue cage 16 and a hydraulic cylinder (not shown) maintains the rescue cage 16 in the vertical position, independent of the position of the whole turntable ladder and of the hinged arm 14.

[0023] In order to secure the connection of the hinged arm 14, or rather the end section 30, to the rescue cage 16, lateral support brackets 42,44 are provided between the end section 30 and the rescue cage 16. These sup-

port brackets 42,44, which serve as a type of railing, slide along the upper members at the side of the end section 30 with the help of tracks 46, so that they can adapt to every inclination of either the ladder or rescue cage 16 respectively.

[0024] In Fig. 2, moreover, the outline of a drag chain 48 can be seen. This drag chain serves to transfer all electrical supply and control cables from the ladder via the base section 22 to the end section 30. Further connections between the end section 30 and the rescue cage 16 are not shown in detail. A telescopically extendable water supply line for the delivery of water for fire-fighting is situated in the connecting area between the base section 22 and the end section 30.

[0025] Fig. 3 corresponds to Fig. 2 and shows the hinged arm in the extended position while Fig. 4 illustrates the retracted position. The reference numbers of Fig. 2 are used for corresponding parts in Fig. 3 and 4, so that an additional, detailed explanation is unnecessary.

[0026] The same applies to Fig. 5. Fig. 5 is a top view of the end region of the ladder and hinged arm 14 in the extended position. A rotary leadthrough 50 for a fire-fighting water supply line 52 can be identified in the region of the pivot 20 of the hinged arm. In the region shown, the fire-fighting water supply line 52 consists of an outer pipe 54 and an inner pipe 56, which generate a telescopic connection at the transition from the base section 22 to the end section 30.

Claims

1. Turntable ladder for rescue vehicles with a number of telescopically extendable ladder elements, on the last of which a hinged arm (14), formed as a ladder element, is pivot-mounted about a horizontal pivot (20) **characterized in that** the hinged arm (14) is telescopically extendable and consists of a base section (22) pivot-mounted to the end of the last ladder element, and, with respect to this, a telescopically displaceable end section (30), each one of said base (22) and end (30) sections has lower members (24,32), bridged by rungs (26,34), and upper members (28, 36), serving as railings, which are connected as a lattice framework and which, as a whole, form a U-shaped cross-section.
2. Turntable ladder according to Claim 1, **characterised in that** the end section (30) can be telescopically slid inside the U-shaped base section (22).
3. Turntable ladder according to one of the preceding claims, **characterised in that** a rescue cage (16) is attached to the end of the end section (30).
4. Turntable ladder according to one or more of the preceding claims, **characterised in that** brackets (42,44), serving as railings, which slide on the upper

members (36) of the end section (30), are provided between the rescue cage (16) and end section (30).

- Turntable ladder according to one or more of the preceding claims, **characterised in that** a telescopically extendable fire-fighting water supply line (52), runs along the hinged arm (14) and forms a connection to a fire-fighting water supply at the extreme end of the end section.

Patentansprüche

- Drehleiter für Rettungsfahrzeuge mit einer Anzahl teleskopisch ausfahrbarer Leiterelemente, wobei an das letzte von diesen ein angelenkter Arm (14), der als ein Leiterelement gebildet ist, um einen horizontalen Drehzapfen (20) drehbar montiert ist, **dadurch gekennzeichnet, dass** der angelenkte Arm (14) teleskopisch ausfahrbar ist und aus einem Basisteilstück (22), das schwenkbar an dem Ende des letzten Leiterelements montiert ist, und einem mit Bezug zu diesem teleskopisch verschiebbaren Endteilstück (30) besteht, wobei ein jedes von den Basis-(22) und End-(30)-Teilstücken untere Elemente (24, 32), die durch Sprossen (26, 34) überbrückt sind, und obere Elemente (28, 36) aufweist, die als Geländer dienen, welche wie ein Gitterrahmen verbunden sind und welche insgesamt einen U-förmigen Querschnitt bilden.
- Drehleiter nach Anspruch 1, **dadurch gekennzeichnet, dass** das Endteilstück (30) teleskopisch in das U-förmige Basisteilstück (22) eingeschoben werden kann.
- Drehleiter nach einem der vorhergehenden Ansprüche, **dadurch gekennzeichnet, dass** an dem Ende des Endteilstücks (30) ein Rettungskorb (16) angebracht ist.
- Drehleiter nach einem oder mehreren der vorhergehenden Ansprüche, **dadurch gekennzeichnet, dass** Bügel (42, 44), die als Geländer dienen, welche auf den oberen Elementen (36) des Endteilstücks (30) gleiten, zwischen dem Rettungskorb (16) und dem Endteilstück (30) vorgesehen sind.
- Drehleiter nach einem oder mehreren der vorhergehenden Ansprüche, **dadurch gekennzeichnet, dass** eine teleskopisch ausfahrbare Löschwasserversorgungsleitung (52) entlang des angelenkten Arms (14) verläuft und eine Verbindung mit einer Löschwasserversorgung an dem äußersten Ende des Endteilstücks bildet.

Revendications

- Échelle pivotante pour véhicules de secours, avec un nombre d'éléments d'échelle extensibles de façon télescopique, sur le dernier desquels un bras articulé (14), sous forme d'élément d'échelle, est monté de façon pivotante autour d'un pivot horizontal (20), **caractérisé en ce que** le bras articulé (14) est extensible de façon télescopique et est constitué d'une section de base (22) montée de façon pivotante sur l'extrémité du dernier élément d'échelle, et, par rapport à celle-ci, une section d'extrémité (30) déplaçable de façon télescopique, chacune parmi lesdites sections de base (22) et d'extrémité (30) comporte des éléments inférieurs (24, 32), sur lesquels des barreaux (26, 34) s'étendent, et des éléments supérieurs (28, 36), servant de garde-corps, qui sont reliés sous forme de bâti en treillis et qui, dans l'ensemble, forment une section transversale en forme de U.
- Échelle pivotante selon la revendication 1, **caractérisé en ce que** la section d'extrémité (30) peut coulisser de façon télescopique à l'intérieur de la section de base en forme de U (22).
- Échelle pivotante selon une des revendications précédentes, **caractérisé en ce qu'**une cage de secours (16) est fixée à l'extrémité de la section d'extrémité (30).
- Échelle pivotante selon une ou plusieurs des revendications précédentes, **caractérisé en ce que** des supports (42, 44), servant de garde-corps, qui coulisser sur les éléments supérieurs (36) de la section d'extrémité (30), sont prévus entre la cage de secours (16) et la section d'extrémité (30).
- Échelle pivotante selon une ou plusieurs des revendications précédentes, **caractérisé en ce qu'**une conduite d'alimentation en eau (52) de lutte contre l'incendie, extensible de façon télescopique, se trouve le long du bras articulé (14) et forme un raccordement à une conduite d'alimentation en eau de lutte contre l'incendie à l'extrémité de la section d'extrémité.

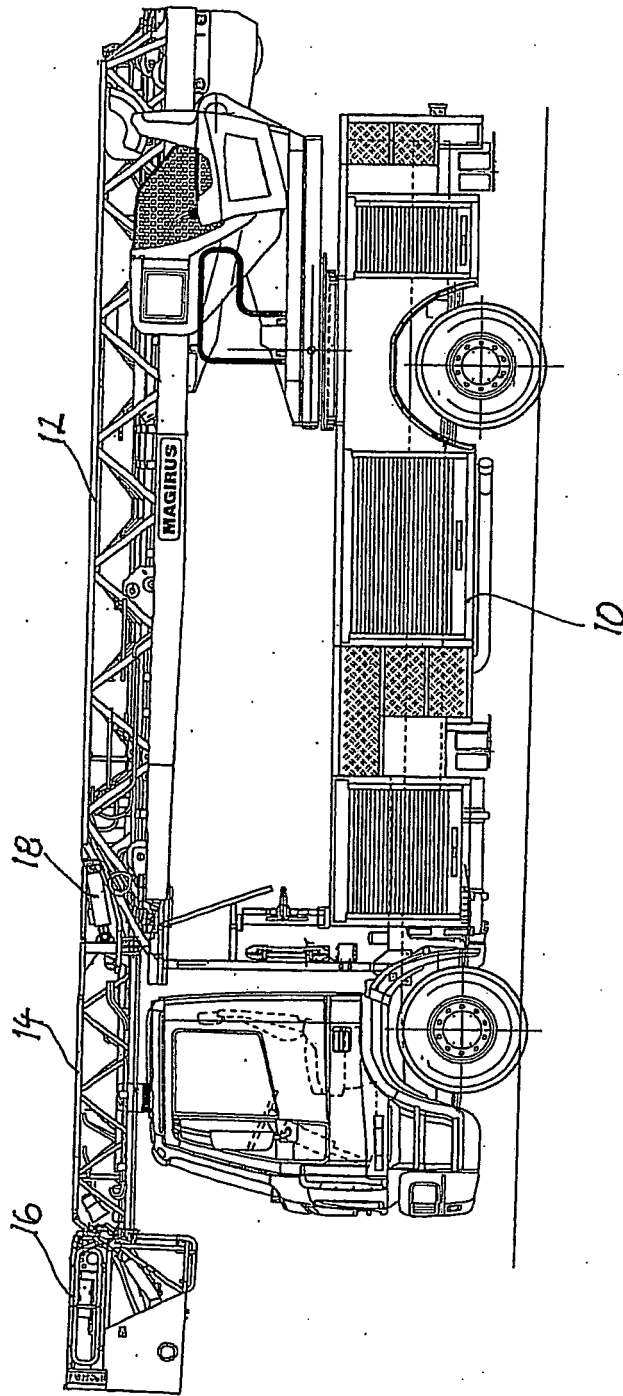
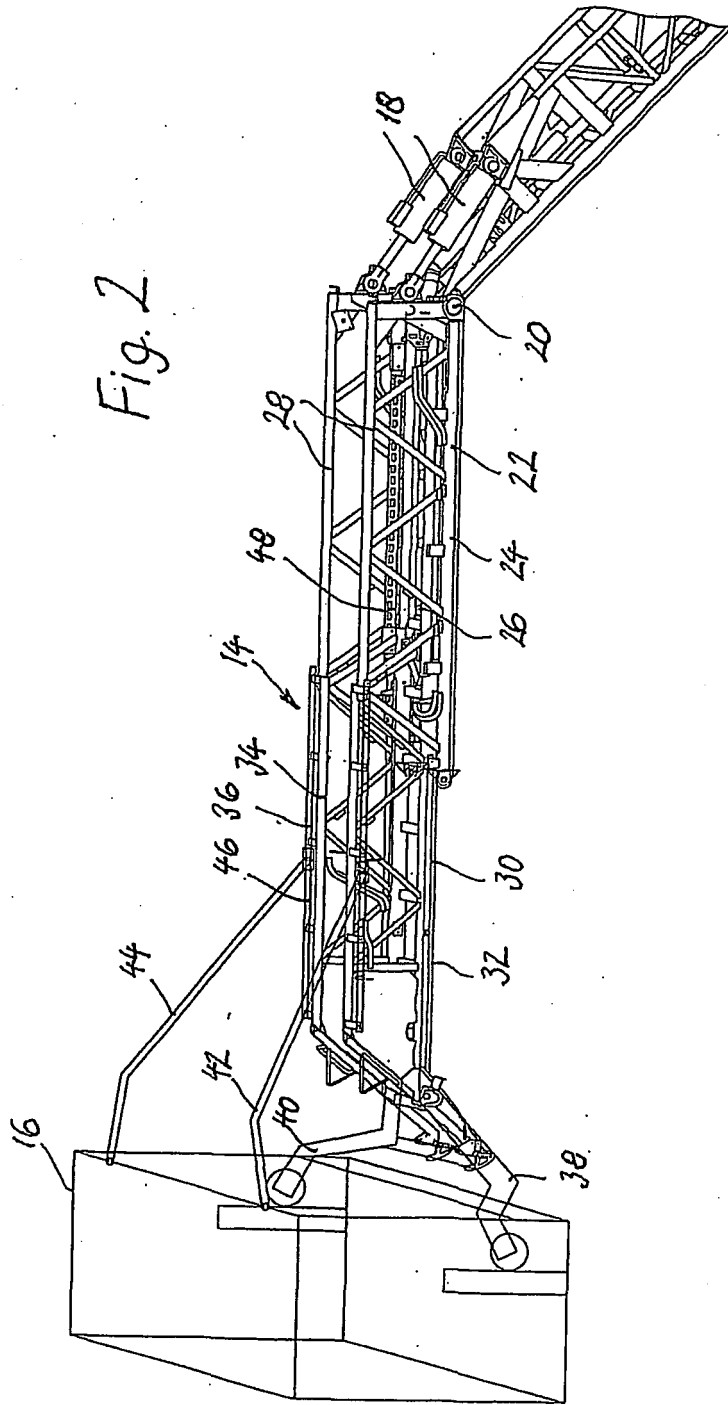
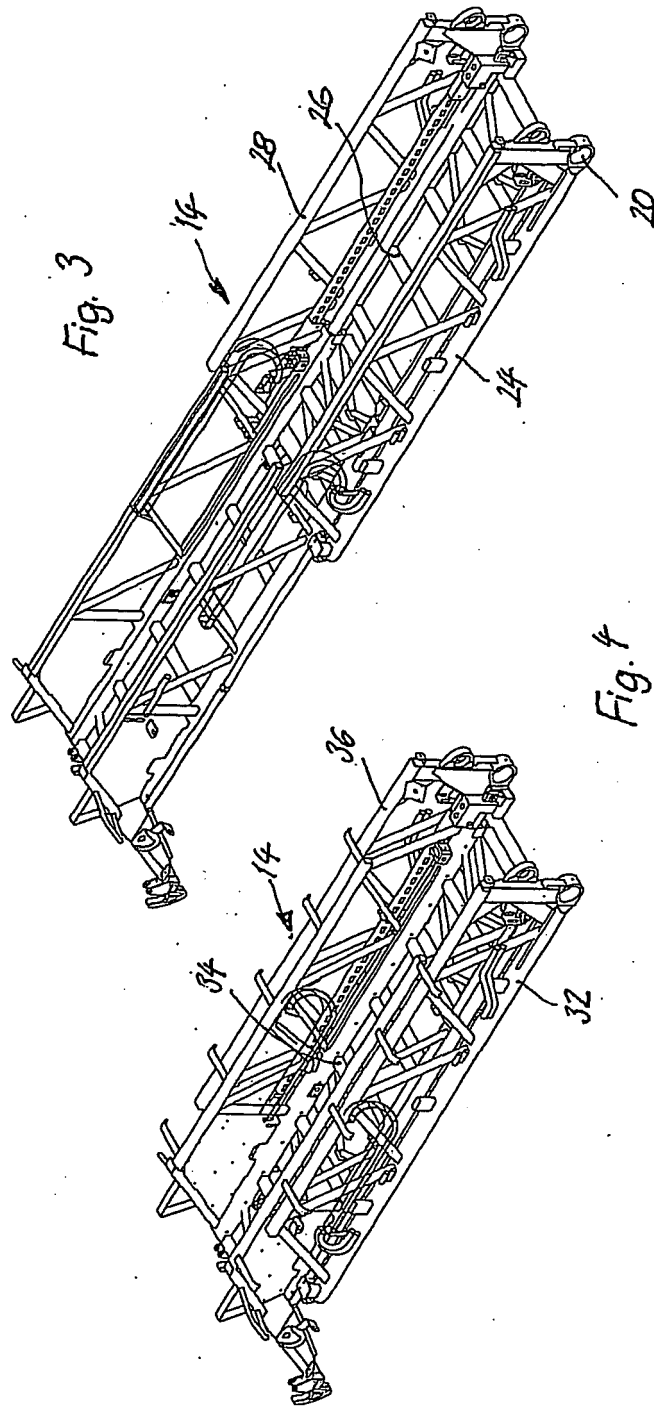
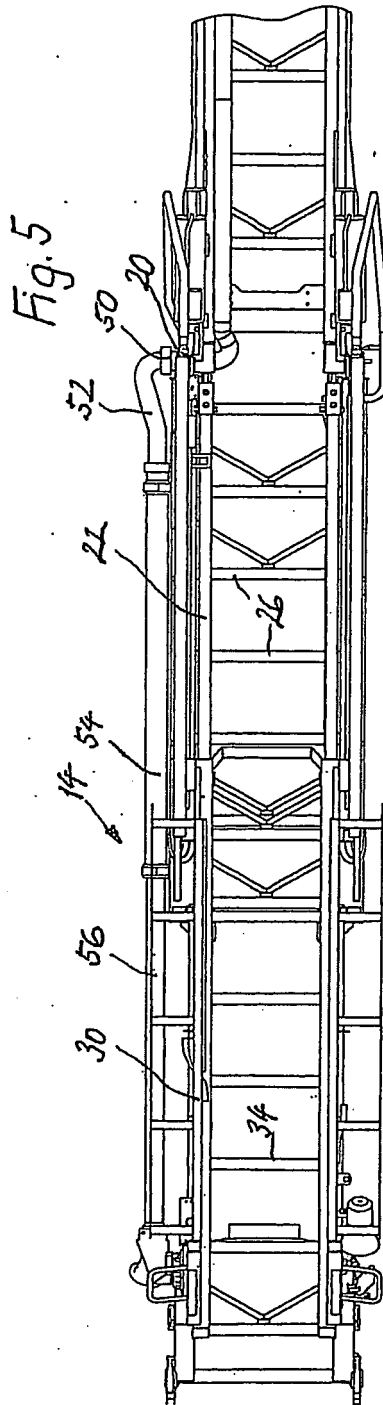

Fig. 1







REFERENCES CITED IN THE DESCRIPTION

This list of references cited by the applicant is for the reader's convenience only. It does not form part of the European patent document. Even though great care has been taken in compiling the references, errors or omissions cannot be excluded and the EPO disclaims all liability in this regard.

Patent documents cited in the description

- DE 9416367 U1 [0002]
- DE 2348164 A [0007]
- DE 2652244 A [0007]
- DE 4221673 C [0007]
- EP 217294 A [0007]
- EP 522315 A [0007]
- DE 9416367 U [0008] [0009]