



US 20060260603A1

(19) **United States**

(12) **Patent Application Publication**
Shah

(10) **Pub. No.: US 2006/0260603 A1**

(43) **Pub. Date: Nov. 23, 2006**

(54) **GAS FLOW CONTROL SYSTEM FOR GAS BARBEQUE AND THE LIKE**

(52) **U.S. Cl. 126/41 R**

(75) **Inventor: Reza H. Shah, Acton (CA)**

(57) **ABSTRACT**

Correspondence Address:
OGILVY RENAULT LLP
1981 MCGILL COLLEGE AVENUE
SUITE 1600
MONTREAL, QC H3A2Y3 (CA)

(73) **Assignee: Pioneering Technology Inc.**

A gas control system having: a valve body having a preliminary chamber, an inlet orifice in communication with said preliminary chamber, an outlet orifice on said valve body in communication with a gas burning device, a main chamber within said valve body, said main chamber and said preliminary chamber communicating through a valve opening, a stopper in said preliminary chamber and normally urged by a compression spring located in said preliminary chamber to engage with said valve opening to close communication between said preliminary chamber and said main chamber, an elongated slidable rod slidably mounted in said valve body and having an inner end portion juxtaposed with said stopper washer, and a pressing arm juxtaposed with another end of said slidable rod and operative for pressing said slidable arm inwards to disengage said stopper washer from said valve opening for releasing the gas in said preliminary chamber into said outlet orifice.

(21) **Appl. No.: 11/417,194**

(22) **Filed: May 4, 2006**

Related U.S. Application Data

(60) **Provisional application No. 60/677,819, filed on May 5, 2005.**

Publication Classification

(51) **Int. Cl.**
F24C 3/00 (2006.01)

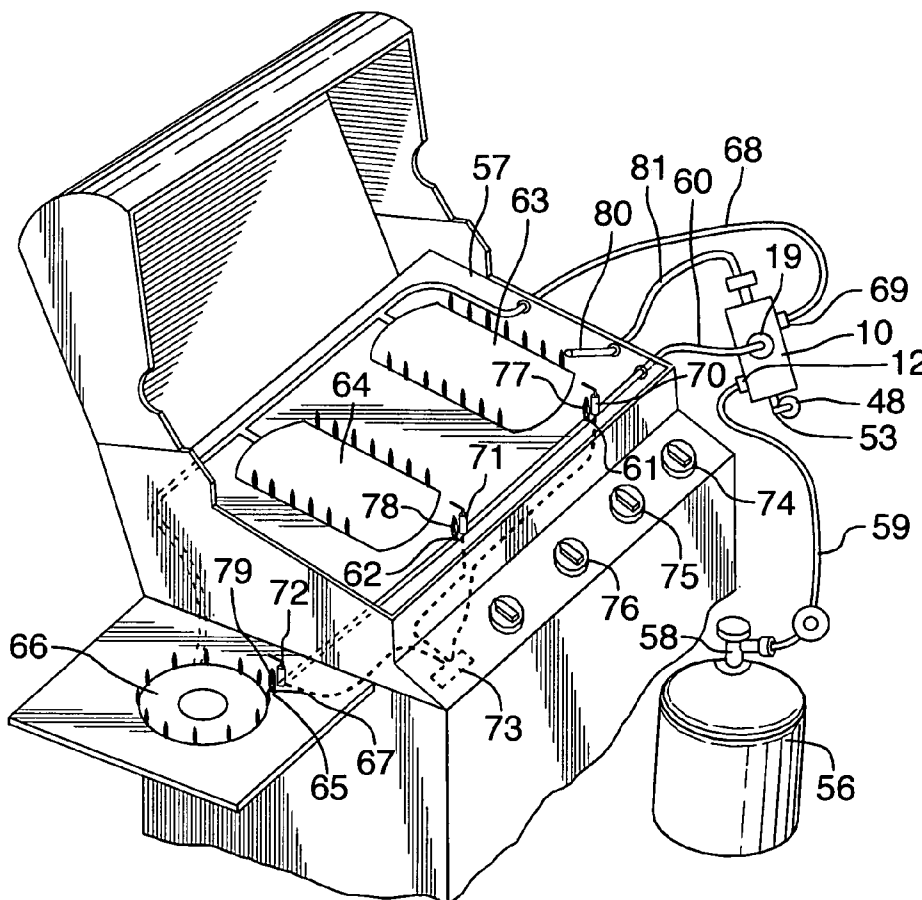

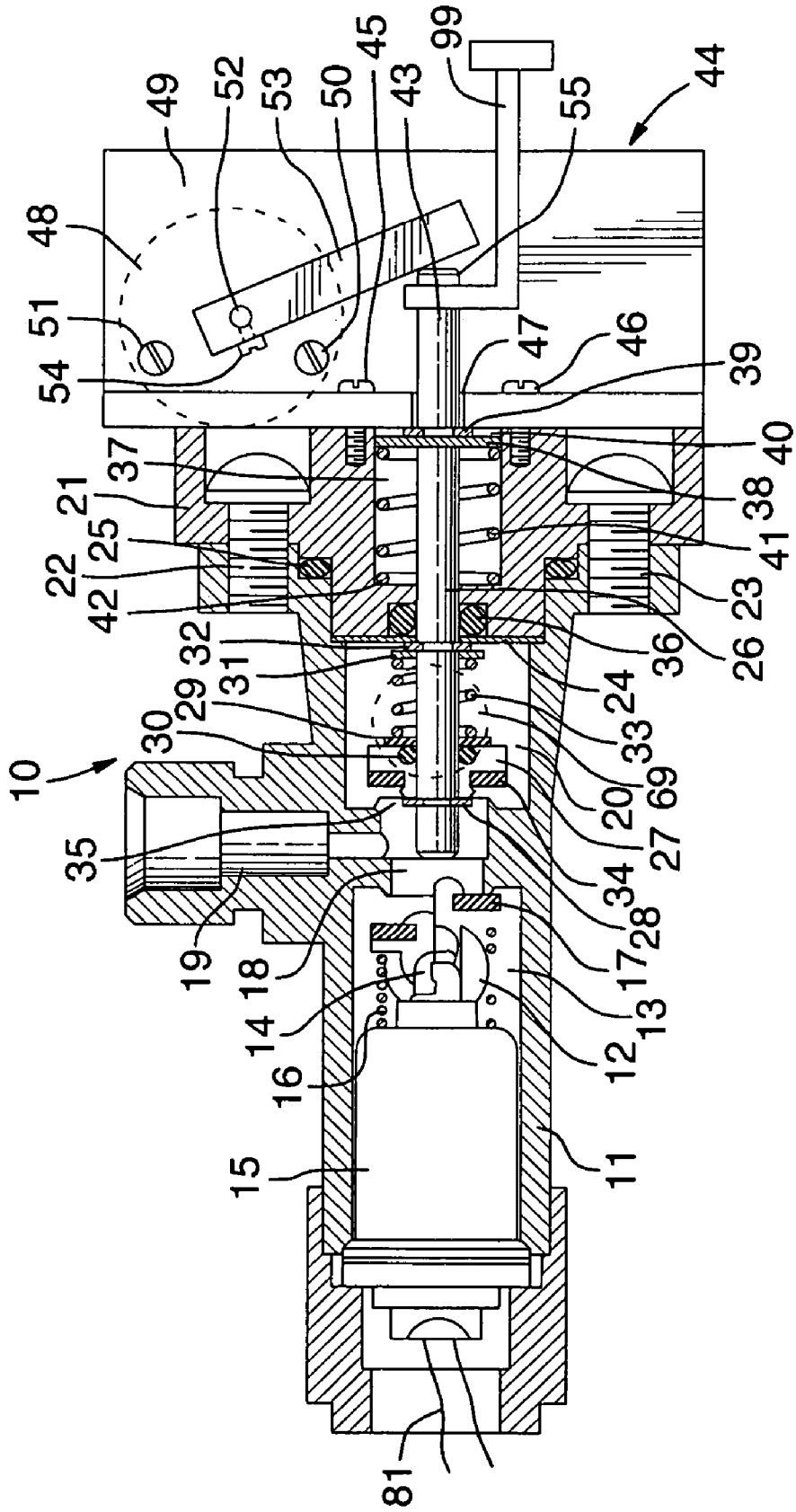

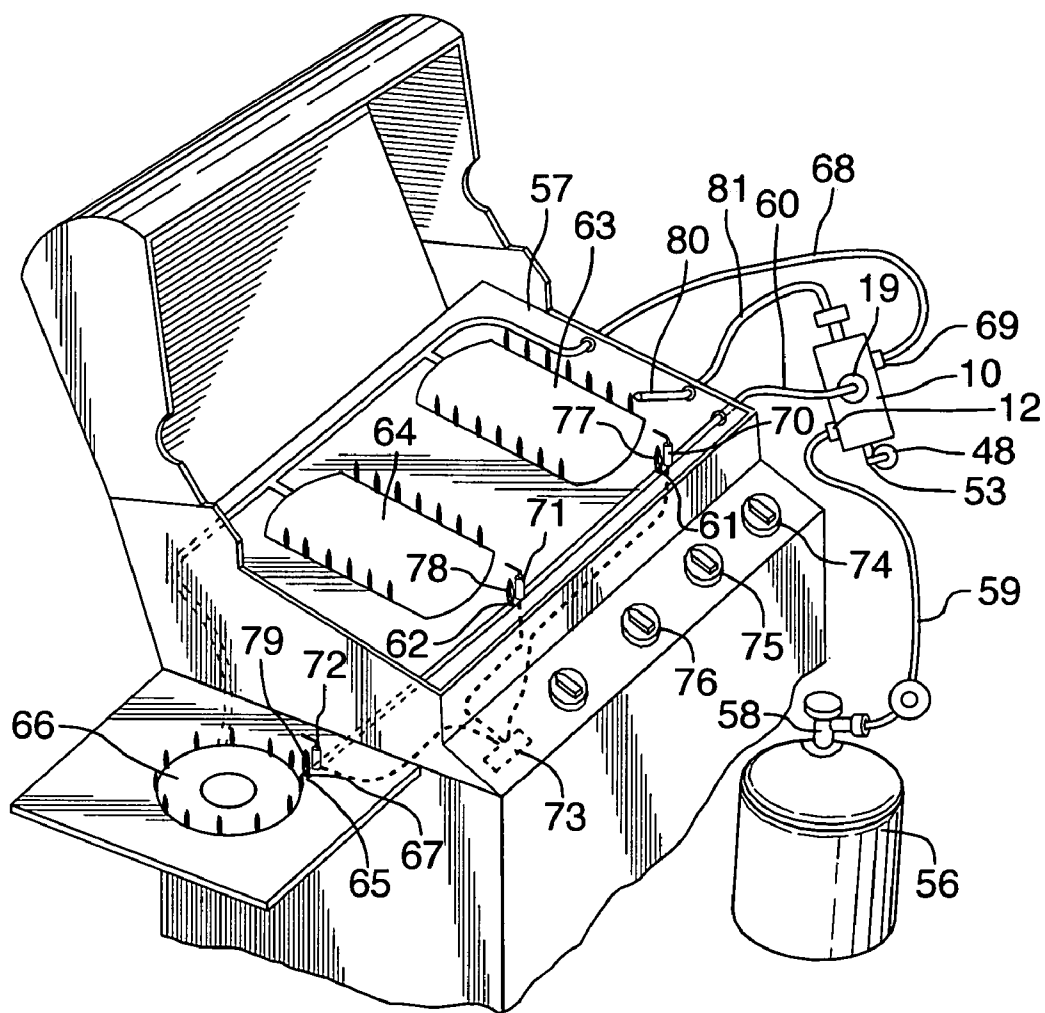

FIG.2

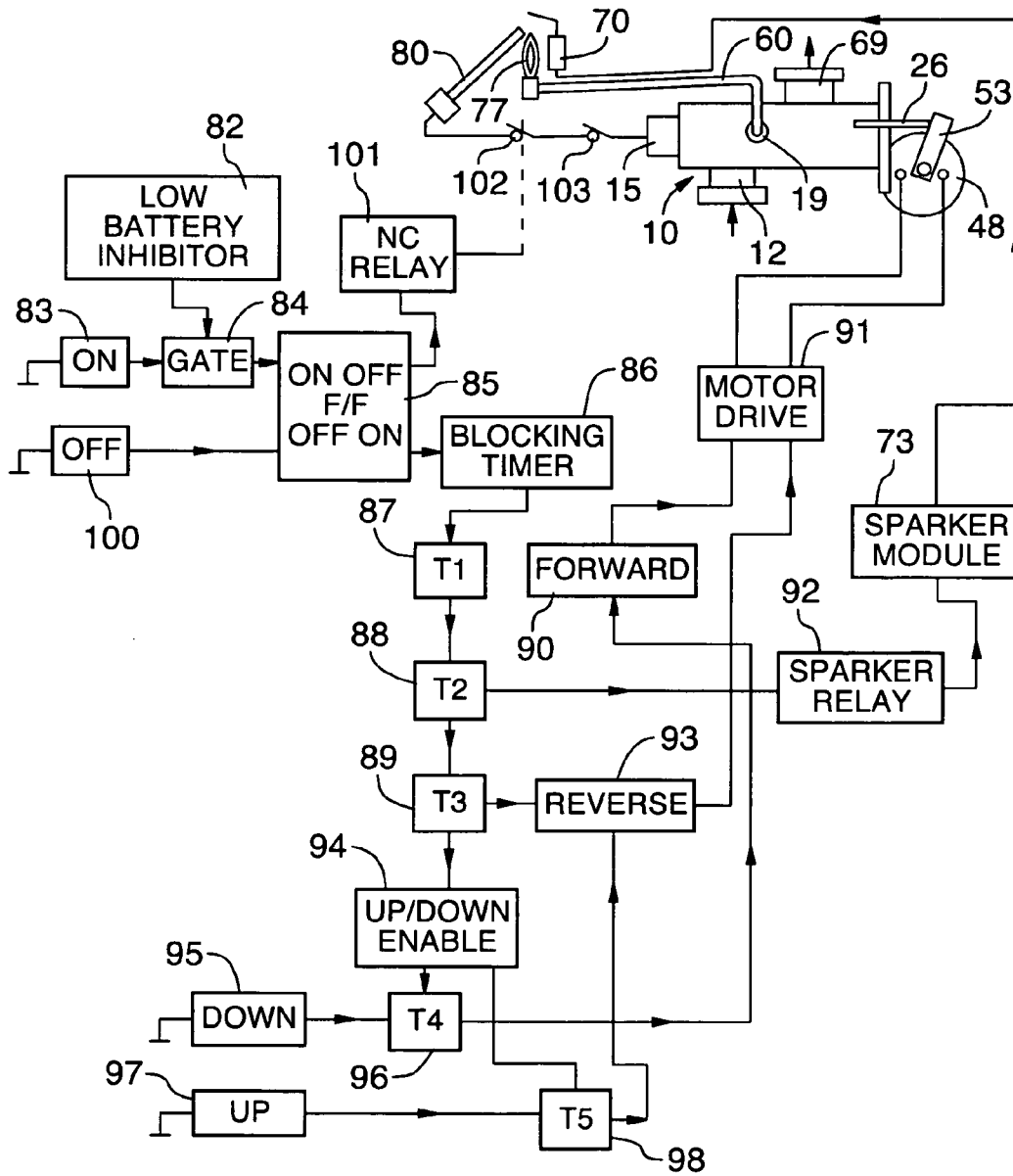

FIG.3

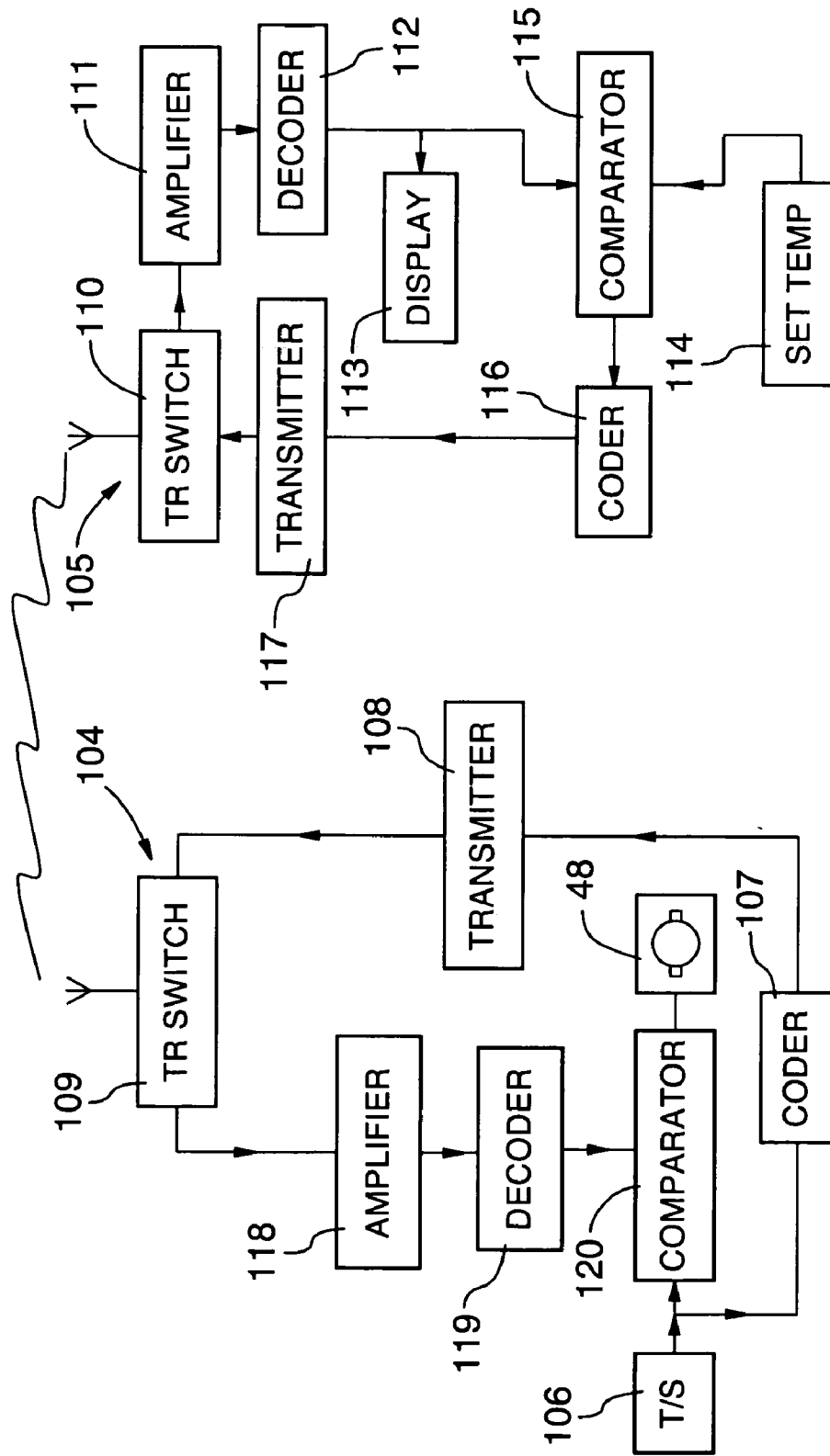

FIG.4

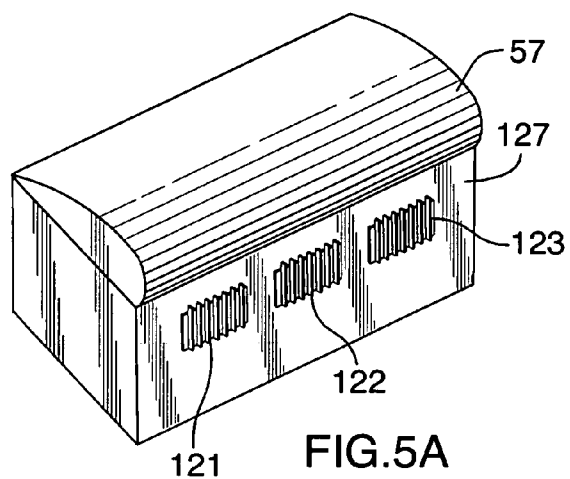

FIG. 5A

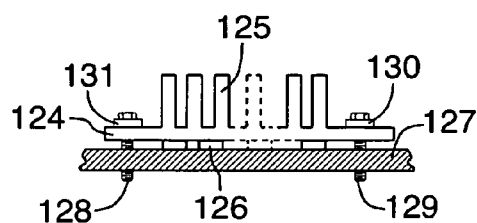

FIG. 5B

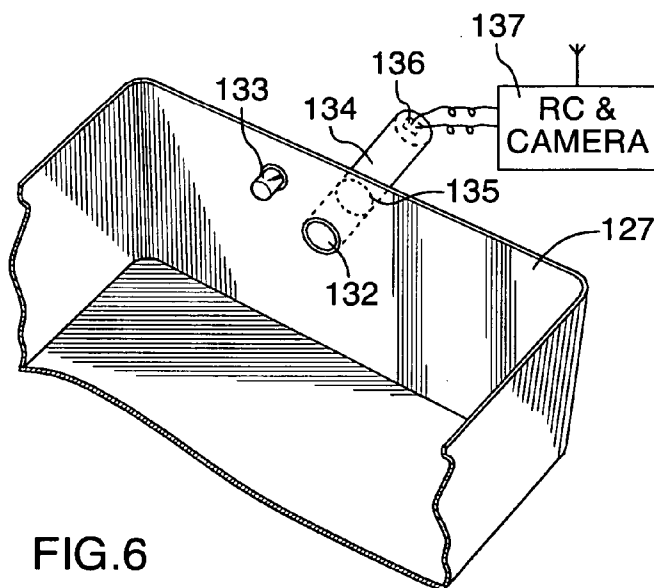

FIG. 6

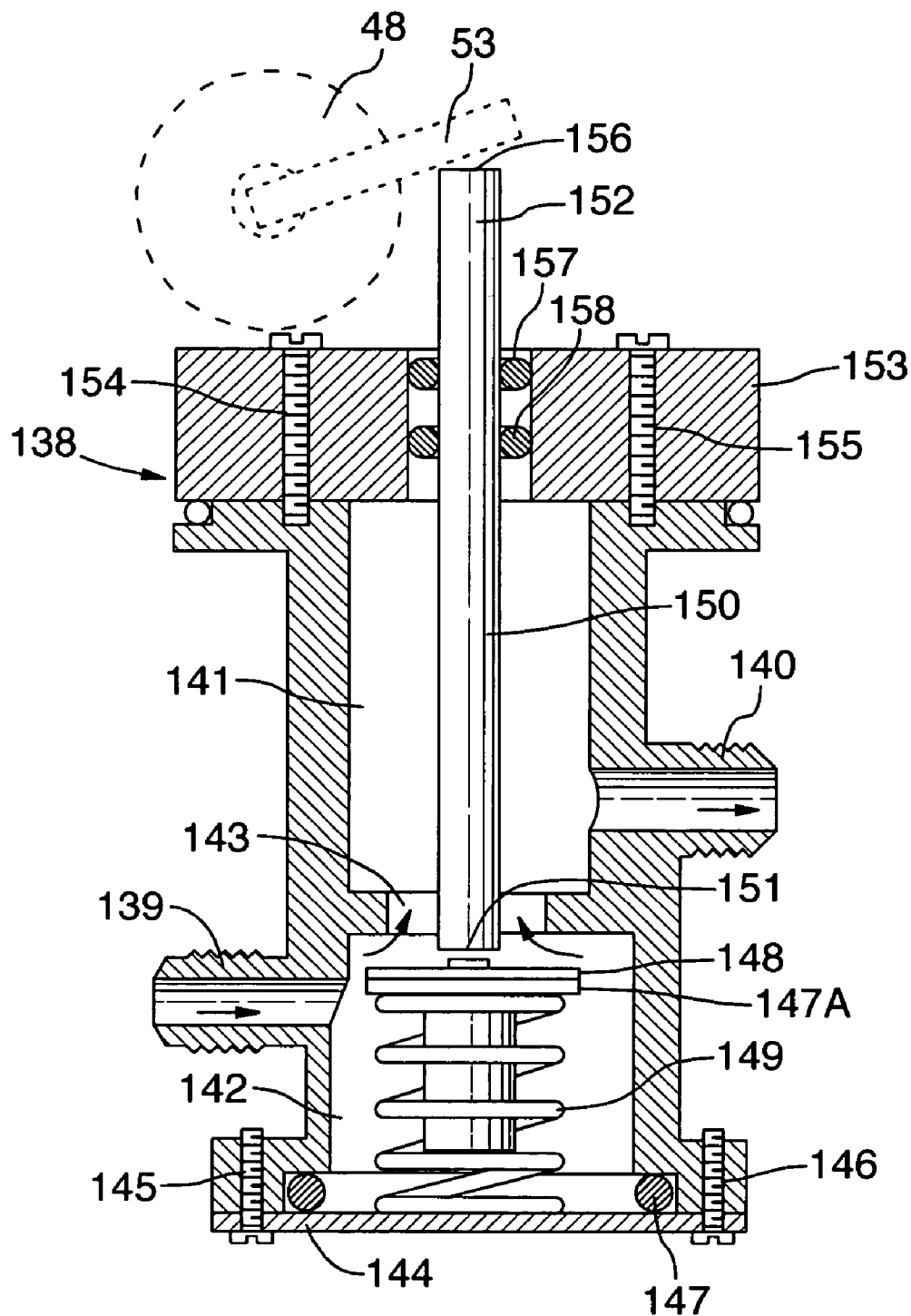

FIG. 7

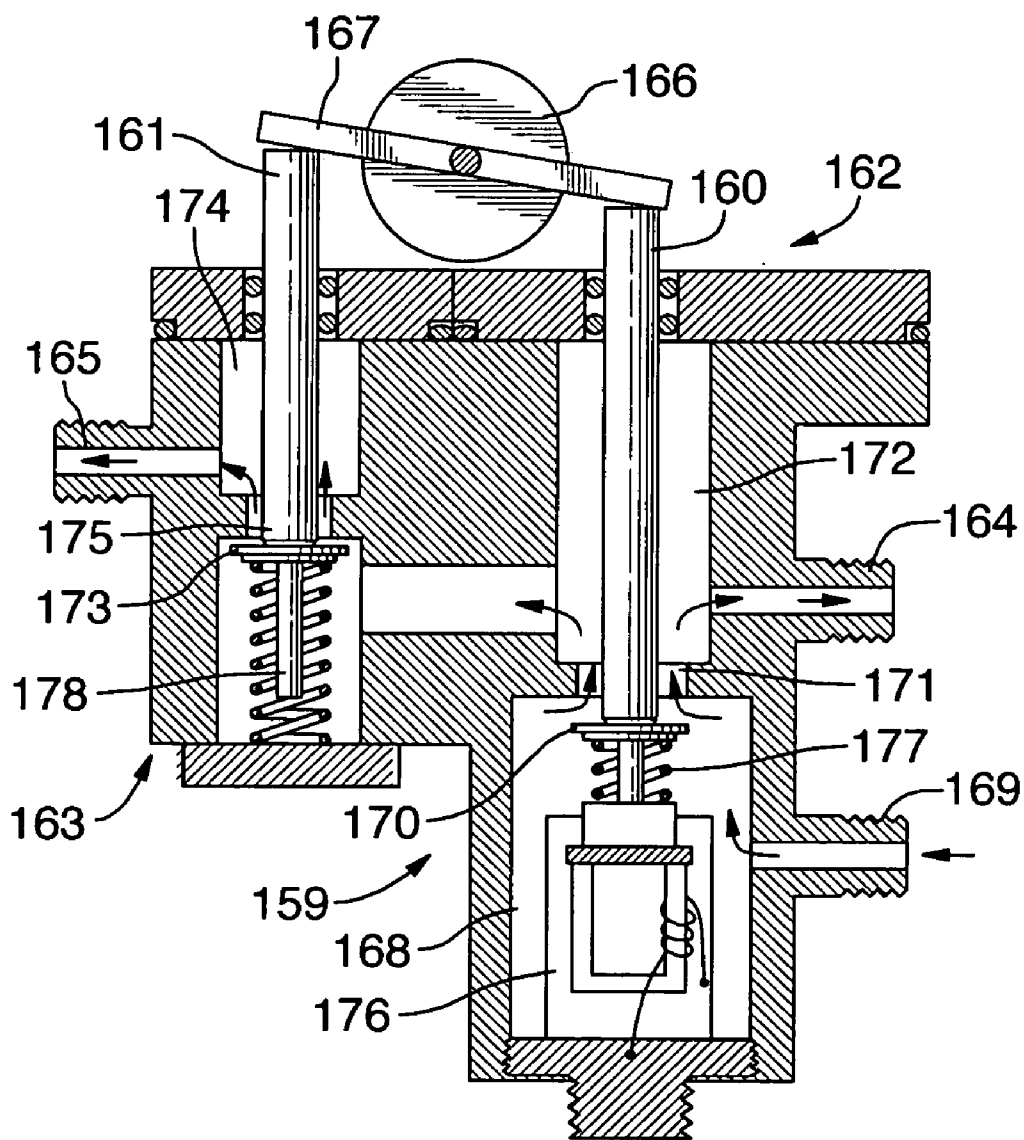

FIG.8

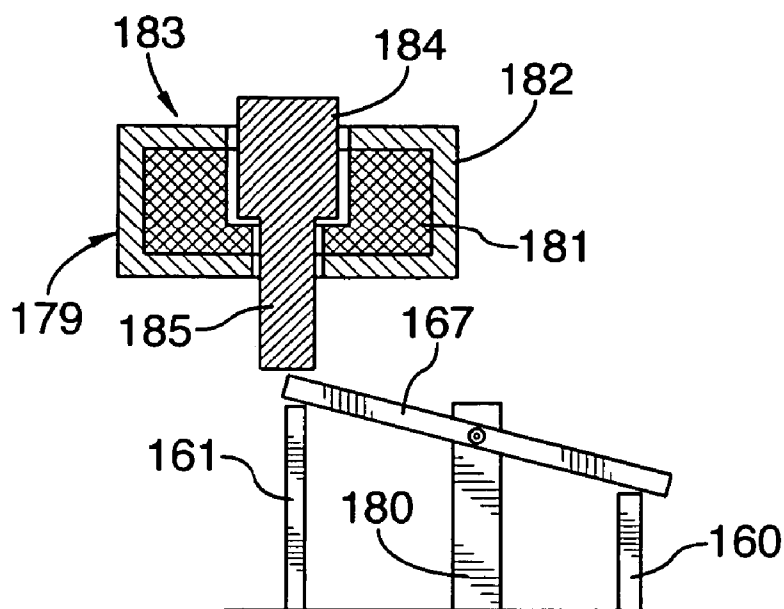

FIG. 9

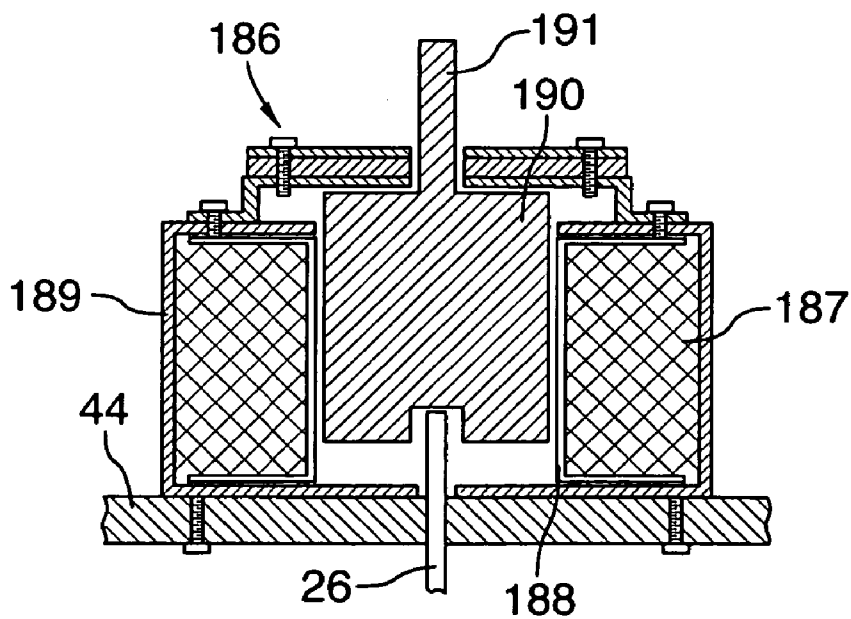

FIG. 10

GAS FLOW CONTROL SYSTEM FOR GAS BARBEQUE AND THE LIKE

TECHNICAL FIELD

[0001] The invention relates to a remote control system for igniting and controlling a plurality of operations of a gas burning device such as a barbeque for example.

BACKGROUND OF THE ART

[0002] Gas burning devices such as barbeque devices are usually convenient to use and are easy to maintain. However, users of gas barbeque devices in particular have been fearful in igniting and adjusting the operation of the gas burner in the device in use because of the potential danger of gas accumulation and explosion in such operation. Particularly, since the user must stand immediately close to the device to perform the igniting operation usually with a match or lighter, and repeated failure to ignite the device, such as in a windy condition, would result in leakage of gas into the area around the device that could result in a gas explosion, and a gas explosion until such circumstances could cause fatal harm to the user. In areas of cold climate it is also very uncomfortable to ignite a barbeque device outdoors. Remote controlled syrods have been developed for igniting a gas barbeque device without the user situated immediate adjacent to the device. However, they do not address all the requirements of the users such as the capability of controlling the operation of the device after it has been ignited.

[0003] To reduce the difficulties associated with manually ignited gas burning devices, it is advantageous to produce a remote control system for igniting on a pilot on demand basis and controlling a plurality of operations of a barbeque device during use. A desirable remote control system may be operative for monitoring the temperature and condition of the food being cooked in the barbeque. To reduce energy requirements and need for battery replacements a thermoelectric generating system may be desired for operating various components

[0004] Objects of the invention will be apparent from review of the disclosure, drawings and description of the invention below.

DISCLOSURE OF THE INVENTION

[0005] The invention provides a gas control system having: a valve body having a preliminary chamber, an inlet orifice in communication with said preliminary chamber, an outlet orifice on said valve body in communication with a gas burning device, a main chamber within said valve body, said main chamber and said preliminary chamber communicating through a valve opening, a stopper in said preliminary chamber and normally urged by a compression spring located in said preliminary chamber to engage with said valve opening to close communication between said preliminary chamber and said main chamber, an elongated slidable rod slidably mounted in said valve body and having an inner end portion juxtaposed with said stopper washer, and a pressing arm juxtaposed with another end of said slidable rod and operative for pressing said slidable arm inwards to disengage said stopper washer from said valve opening for releasing the gas in said preliminary chamber into said outlet orifice.

DESCRIPTION OF THE DRAWINGS

[0006] In order that the invention may be readily understood, embodiments of the invention are illustrated by way of example in the accompanying drawings.

[0007] FIG. 1 is a sectional view of the control valve for controlling the flow of gas to the burner and the pilot on demand arrangement in a first embodiment of the system of the present invention.

[0008] FIG. 2 is a perspective top elevation of the gas barbeque device provided with the control valve of the remote control system of the present invention.

[0009] FIG. 3 is a schematic block diagram showing the remote control system of the present invention.

[0010] FIG. 4 is a schematic block diagram showing the two way communication between the remote control and the barbeque device in the remote control system of the present invention.

[0011] FIG. 5A is a perspective top rear elevation view of the barbeque unit provided with a plurality of thermoelectric generating modules for providing operating electrical power to components of the present system.

[0012] FIG. 5B is an enlarged view of the thermoelectric generating module of FIG. 5A.

[0013] FIG. 6 is a top view of the barbeque device with open lid showing the provision of video components for monitoring the condition of the food being cooked in the barbeque device.

[0014] FIG. 7 is a sectional view of a gas valve according to a second embodiment of the invention for controlling the gas supplied to the barbeque device.

[0015] FIG. 8 is a sectional view of a third embodiments of a gas valve having a counterbalance lever arrangement for controlling the gas supplied to the barbeque device.

[0016] FIG. 9 is a sectional view of an electromagnetic drive for the gas valve of FIG. 8.

[0017] FIG. 10 is a sectional view of an electromagnetic drive for the syrod of the present invention.

[0018] Further details of the invention and its advantages will be apparent from the detailed description included below.

DETAILED DESCRIPTION OF PREFERRED EMBODIMENTS

[0019] With reference to FIG. 1, a first embodiment of the invention includes a gas control valve 10 for the remote control system of the present invention has a main body 11 which has a gas inlet orifice 12 for admitting the incoming gas into a preliminary chamber 13. The inlet orifice 12 is normally closed by a plunger 14 operated by an electromagnetic control safety device 15 and a biasing spring 16. The plunger 14 has a rubber washer 17 which is normally maintained engaged with the admitting opening 18 by the biasing spring 16 to prevent the incoming gas from passing through the admitting opening 18 to the pilot orifice 19 and the main chamber 20. A top body 21 is mounted to the main body 11 by bolts 22 and 23 and a circular washer 24 together with O-ring 25 seal the joint between the two bodies. An

elongated rod 26 is slidably mounted within the top body 21. A bushing 27 is mounted at the inner portion of the rod 26 located within the main chamber 20. The bushing 27 is retained in place by a retaining ring 28 and a rubber washer 29 fixedly mounted on the rod 26. An O-ring 30 is located between the rubber washer 29 and the bushing 27. Another washer 31 is mounted on the rod 26 and located adjacent to the circular washer 24. The washer 31 is retained in place by a retaining ring 32. A compression spring 33 is located between the rubber washer 29 and the washer 31 to maintain the bushing 27 firmly pressing against the retaining ring 28. A rubber washer 34 is mounted on the bushing 27 on the side facing the main opening 35 leading into the main chamber 20. An O-ring 36 is provided between the circular washer 24 and the top body 21 to prevent any leakage of gas between the slidable rod 26 and the top body 21. The middle portion of the slidable rod 26 is located in an inner chamber 37. A washer 38 is mounted on the slidable rod 26 adjacent to a front opening 39 of the inner chamber 37, and retaining ring 40 maintains the washer 38 fixedly mounted in place on the slidable rod 26. A compression spring 41 is located in the inner chamber 37 and extends between the rear wall 42 of the inner chamber 37 and the washer 38. The spring force of the compression spring 41 cooperating with the washer 38 to maintain the slidable rod 26 normally in the position with its front end portion 43 extending outside the front opening 39 as best shown in FIG. 1. An angle support 44 is mounted to the front side of the top body 21 by bolts 45 and 46. The front end portion 43 of the slidable rod 26 extends outwards of an opening 47 of the angle support 44. A drive motor 48 preferably having a high step down gear ratio as shown in a dotted circular line in FIG. 1 is mounted on the perpendicular plate 49 of the angle support 44 by screws 50 and 51. The drive shaft 52 of the motor 48 extends outwards of the perpendicular plate 49, and a pivotal arm 53 is mounted to the drive shaft 52 by a set screw 54. The side of the pivotal arm 53 is juxtaposed to the front end 55 of the slidable rod 26 so that the pivotal arm 53 is pivotable to push the slidable rod 26 to move inwards of the gas control valve 10.

[0020] As shown in FIG. 2, the gas control valve 10 is connected between the gas supply such as the natural gas supply or a portable propane gas tank 56 and the barbeque unit 57. For simplicity of illustration, a propane gas tank is shown. In the well known manner, a gas regulator 58 is provided between the gas supply and the barbeque unit when a propane gas tank is used. The gas supply line 59 connects between the gas regulator 58 and the inlet orifice 12 of the gas control valve 10. An elongated pilot gas tube 60 is connected to the pilot orifice 19 of the gas control valve 10. The pilot gas tube 60 extends into the barbeque unit 57 and it is provided with pilot openings 61 and 62 located closely adjacent to the gas burners 63 and 64. Only one pilot opening may be provided if the barbeque unit has only one gas burner. Two burners are shown as an example. The end 65 of the pilot tube 60 may also extend to locate adjacent to a side burner 66 if such side burner is provided on the barbeque unit, and a pilot opening 67 is provided at the end portion of the pilot tube 60. A main gas line 68 is connected between the output orifice 69 of the gas control valve 10 and the gas burners 63 and 64 and the side burner 66. Pilot flame igniters 70, 71 and 72 are located adjacent to the pilot openings 61, 62 and 67 respectively. The pilot flame igniters 70, 71 and 72 are operated by a sparker module 73 mounted on the barbeque unit 57. The barbeque unit 57 may be

provided with manually adjustable gas control valve 74, 75 and 76 for manual adjustment of the burner flame in the well known manner. The two burner and one side burner barbeque unit is shown as an example for illustrating the present invention. The system may be adapted for use with barbeque units have only one burner or a plurality of burners and with or without a side burner by the appropriate elimination or addition of components.

[0021] In operation, the gas control valve 10 is operated by actuating the motor 48 is so that the pivotal arm 53 is pivoted in a clockwise direction to push the slidable rod 26 to move inwards of the valve 10 until the rear end 56 of the slidable rod 26 pushes the rubber washer 17 of the plunger 14 to disengage from the admitting opening 18 while the rubber washer 34 of the bushing 27 is pressed tightly against the opening 35 to seal the communication between the preliminary chamber 12 and the main chamber 20 so that in the incoming gas flows into the pilot orifice 19 through the admitting opening 18 to the pilot tube 60. The igniters 70, 71 and 72 are actuated by the sparker module 73 to provide the spark for igniting the gas emitting from the pilot openings 61, 62 and 67 to provide the pilot flames 77, 78 and 79 adjacent to the gas burners 63, 64 and 66 respectively. After the pilot flames 77, 78 and 79 have been ignited, the heat of the pilot flame 77 is detected by a thermoelectric converter 80 to provide an electric current which is conducted by lead wires 81 connected to the electromagnetic control safety device 15 to operate the latter so as to hold the plunger 14 down in order for the gas to continue flowing to the pilot orifice 19. The motor 41 is then operated in the reverse direction so as to pivot the pivotal arm 53 in the counter-clockwise direction to allow the slidable rod 26 to move outwards by the spring force of the compression springs 33 and 41. The washer 34 of the bushing 27 is then engaged from the main opening 35 so that incoming gas flows into the main chamber 20 to exit through the outlet orifice 69. The incoming gas continues to flow to the pilot tube 60 through the pilot orifice 19 since the plunger 14 is now held down by the electromagnet control safety device 15. The gas emitting from the gas burners 63, 64 and 66 are then ignited by the pilot flames 77, 78 and 79 respectively. After the burners 63, 64 and 66 have been ignited, the motor 48 may be operated to move the slidable rod 26 in or out in selective degree so as to modulate the amount of gas flowing to the burners 63, 64 and 66 for adjusting the size of the flame of the burners to select the desirable cooking requirement. The motor 48 of the gas control valve 10 operate through the above three time period sequence including starting the barbeque unit until controlling the required cooking conditions during cooking.

[0022] As shown in FIG. 3, the electronic system for operating the gas control valve 10 is, for example, a CMOS logic circuit system. A low battery inhibitor device 82 is provided in the system to ensure that the sequence to start the motor 48 of the gas control valve 10 is not initiated if there is insufficient power for the motor to proceed with the entire sequence of operation as described above. The operation is initiated by actuating an ON signal generator 83 which provides a pulse signal through a gate circuit 84 to the flip-flop circuit 85 to initiate a blocking timer 86 to operate the motor 48 through the above three-period sequence as represented by timing blocks 87, 88 and 89. In the time period T1 as indicated in timing block 87, a forward signal is sent from a forward signal generator as represented

pictorial by the block 90 to drive the motor 48 clockwise as pictorial represented by the block 91 so that the pivotal arm 53 pushes the slidable rod 26 of the gas control valve 10 inwards to permit the incoming gas to flow to the pilot orifice 19. It would also provide the sufficient time period to ensure that the electromagnetic safety device 15 is actuated to hold the plunger 14 in place for the gas to flow from the pilot orifice 19 to the pilot tube 60. The second time period T2 as pictorial represented by block 88 commences when the gas flows to the pilot tube 60. In the time period T2, the motor is not operated while the sparker module 73 is operated by actuating a sparker relay 92 to ignite the igniters 70, 71 and 72 so as to create the pilot flames 77, 78 and 79 from the gas emitting from the pilot openings 61, 62 and 67. After the pilot flame 77 is ignited, the flame actuates the thermoelectric converter 80 to provide the electric power to maintain the plunger 14 down so that gas continues to flow to the pilot tube 60. The time period T3 as represented pictorial by block 89 commences at the termination of time period T2. In the time period T3, the motor 48 is first operated by a reverse signal generated by a reverse signal generator as pictorial represented by reverse block 93 sent to the motor drive 91 to pivot the pivotal arm 53 counterclockwise so that the slidable rod 26 is returned to the position to allow gas to flow through the gas line 68 to the burners 63, 64 and 66. The gas emitting from the burners 63, 64 and 66 is ignited by the pilot flames 77, 78 and 79 thus completing the sequence for igniting the barbeque unit 57.

[0023] After the barbeque unit 57 has been ignited, the condition of the flame of the burners 63, 64 and 66 may be controlled by actuated a flip-flop circuit 94. The flip-flop circuit 94 is actuated by operating a down signal generator 95 which provides a signal to the forward signal generator 90 to rotate the motor 48 in the clockwise direction over a short time period T4 as represented by block 96. Thus, the valve 10 may be adjusted in small incremental steps to reduce the size of the flame of the burners each time the down signal generator 95 is actuated. Similarly, an up signal generator 97 to provide a signal to the reverse signal generator 93 to rotate the motor 48 in the counterclockwise direction over a short time period T5 as represented by block 98. Thus, the valve 10 is adjusted in small incremental steps to increase the size of the flame of the burner flames each time the up signal generator 97 is actuated. The timing of the up and down signal pulses are such that a larger time is allowed when the motor 48, and in turn the slidable rod 26, is operated against the spring force whereas a smaller time pulse is allowed to drive the motor 48 when the latter is cooperated with the spring force to move the slidable rod 26 outwards, which may be a rod secured on a cap attached to cover the front end 55 passing through arm 53 with a button on the end for depressing.

[0024] An override bar 99 is mounted on the front end portion 43, as best shown in FIG. 1, such that the slidable rod 26 may be operated manually by pushing or pulling this override bar.

[0025] To turn the barbeque unit 57 off, an Off signal generator 100 is operated to provide an off signal to the flip-flop circuit 85 to enable a close relay 101 which is in series with the thermoelectric converter 80 and the electromagnetic safety device 15. The close relay 101 is momentarily energized so that the thermocouple switch 102 of the thermoelectric converter 80 is open thus turning off the

operating power to the electromagnetic safety device 15 to release the plunger 14. The valve 10 will then return to the normal condition with the admitting opening 18 closed by the rubber washer 17 to shut off the gas flow to both the pilot orifice 19 and the outlet orifice 69. A manual switch 103 in series with the thermocouple switch 102 may be provided so that the barbeque unit 57 may be conveniently and alternatively turned off by operating this manual switch 103 to shut off the valve 10.

[0026] The gas control valve 10 may be operated with a remote control system as shown in FIG. 4. The remote control system consists of a sensing and control unit 104 and a selection unit 105. The sensing and control unit 104 may be mounted at a strategic location in the barbeque unit for sensing the temperature of the barbeque unit or the food selectively. The temperature of the barbeque unit or the food is detected by a temperature sensor 106 of the sensing and control unit 104. The detected temperature level is converted into a digital or analog signal by a coder 107, which is transmitted via an RF transmitter 108 and channelled through a T/R switch 109. The selection unit 105 receives the temperature level signal via a T/R switch 110. The signal is amplified by an amplifier 111 and decoded by a decoder 112 so that the detected temperature level is shown by a display 113. When the user, after observing the temperature level displayed, may select or alter the temperature to a desirable level by actuating a set temp unit 114 in the selection unit 105. The signal of the set temp unit 114 is compared with the detected temperature level signal from the decoder 112 by a comparator 115 and the resulting temperature level differential is converted to the digital or analog temperature selection coded signal by a coder 116. The temperature selection coded signal is transmitted by transmitter 117 via the T/R switch 110. When the temperature selection coded signal is received by the T/R switch 109 of the sensing and control unit 104 it is amplified by an amplifier 118 and is decoded by a decoder 119. The decoded signal is compared with the temperature level signal from the temperature sensor 106 by a comparator 120 and the resulting differential signal is applied to the motor 48 to operate the motor in a clockwise or counterclockwise direction for adjusting the flame level of the barbeque burners accordingly.

[0027] The electrical power required for operating the sensing and control unit 104 and the gas control valve 10 may be provided by a plurality of thermoelectric generator modules mounted on the barbeque unit. As best shown in FIG. 5A, for example, three thermoelectric generator modules 121, 122 and 123. As best shown in the isolated enlarged top elevation view of FIG. 5B, each thermoelectric generator module has a heat sink 124 having a plurality of spaced parallel fins 125 and a plurality of transducers 126 mounted on the surface opposite to the fins 125. Each thermoelectric generator module 121-123 is mounted to the rear wall 127 of the barbeque unit by bolts 128 and 129 with the transducer therein contacting the barbeque rear wall 127. The bolts 128 and 129 are insulated by ceramic washers 130 and 131. The thermoelectric generator modules 121, 122 and 123 are positioned such that the fins 125 are extending vertically to facilitate the heat emitting by convection from the barbeque unit rear wall 127 or some other convenient location on the barbeque to flow through the vertical spacing between the fins 125. The transducers 126 are connected in series to provide a voltage level sufficient to operate various

electrical components of the system of the present invention. Also, thermopiles may be used as transducers 126 to generate the electrical power with a large voltage level.

[0028] A visual monitoring system as shown in FIG. 6 may be incorporated for viewing and monitoring the condition of the food inside the barbeque during operation. An observation window 132 is formed at the rear wall 127 of the barbeque unit. A light 133 is provided to illuminate the interior of the barbeque unit. A tube 134 is mounted over the observation window and extending outwards rearwardly from the rear wall 127. The view within the barbeque unit as illuminated by the light 133 is enlarged by a lens 135 to provide an image detected by an image sensor 136 such as a CCD device mounted at the rear end of the tube 133. The image may be retrieved by a remote-controlled video camera and transmitter 137 to a video display.

[0029] A simplified gas control valve 138 may be used with a pilot-on-demand barbeque unit. The valve 138 has a gas inlet orifice 139 and a single outlet orifice 140 which provides the gas to both the pilot tube and the burner tube as described above. The valve 138 has a main chamber 141 and a preliminary chamber 142 separated by an opening 143. The preliminary chamber 142 is enclosed by a panel 144 mounted to the valve by bolts 145 and 146. An O-ring 147 is provided between the valve body and the panel 144 to prevent any gas leakage from the valve 138 through the preliminary chamber 142. The inlet orifice 139 communicates with the preliminary chamber 142 and the outlet orifice 140 communicates with the main chamber 141. A T-shaped plunger 147A is located in the preliminary chamber 142. A rubber washer 148 is mounted on the plunger 147A, and the plunger 147A is normally biased by the spring force of a compression spring 149 in the preliminary chamber 142 to press the rubber washer 148 against the opening 143. Thus, the compression spring 149 maintains the opening 143 closed by the rubber washer 148 of the plunger 147A so that gas incoming to the preliminary chamber 142 can not flow through the opening 143 into the main chamber 141. A slidable rod 150 is slidably mounted in the valve 138 and it is largely located in the main chamber 141 with its rear end 151 juxtaposed to the rubber washer 148 of the plunger 147A and its front end portion 152 extending outwards from the top body 153 of the valve 138. Similar to the gas control valve 10 described above, a motor 48 is mounted on an angle support 44 which is attached to the top body 153 by bolts 154 and 155. The pivotal arm 53 is in contact with the front end 156 of the pivotal arm 53 so that operation of the motor 48 will cause the slidable rod 150 to move inwards to disengage the rubber washer 148 from the opening 143 so as to allow incoming gas in the preliminary chamber 142 to flow to the outlet orifice 140 through the main chamber 141. O-rings 157 and 158 are provided between the slidable rod 150 and the top body 153 to prevent gas leakage from the main chamber 141. The valve 138 operates closely similar to the gas control valve 10 with the operation of the motor 48 as described above.

[0030] Another alternative embodiment of the gas control valve is shown in FIG. 8, which is a combination of valve 10 and valve 138 described above. This combination valve 159 has two slidable rods 160 and 161. The slidable rod 160 is provided in the right portion 162 having a construction similar to valve 10 and a left portion 163 similar in construction to valve 138. The right portion 162 controls the gas

flowing to the pilot orifice 164 and the left portion 163 controls the gas flowing to the main gas outlet orifice 165. The slidable rods 160 and 161 are operated by a single motor 166 with a seesaw bar 167 mounted to the motor shaft. One end portion of the seesaw bar 167 is juxtaposed to the outer end of the slidable rod 160 while the other end portion of the seesaw bar 167 is juxtaposed to the outer end of the slidable rod 161. Gas is admitted into the preliminary chamber 168 through the inlet orifice 169. The motor 166 is first operated to rotate in a clockwise manner for pushing the slidable rod 160 inwards so that the rubber washer 170 mounted at the rear end of the slidable rod 160 is disengaged from the opening 171 to facilitate the gas to flow to the pilot orifice 164 through the main chamber 172. At this stage, the opening 173 between the main chamber 172 and the outlet chamber 174 is closed by the rubber washer 175 mounted on the slidable rod 161 so that no gas is flowing from the main chamber 172 to the outlet chamber 174. The pilot flame is ignited when the gas is flowing out of the pilot orifice 164 as described previously. The pilot flame then generates an electrical voltage to energize the electromagnetic safety device 176 to maintain the slidable rod 160 in the inward position and the opening 171 remaining open for gas to continue flowing out of the pilot orifice 164. The motor 166 is then operated to rotate in a counterclockwise direction so that the other end portion of the seesaw bar 167 presses the slidable rod 161 inwards to disengage the rubber washer 175 from the opening 173 so that gas will flow from the main chamber 172 to the outlet chamber 174 and will exit from the outlet orifice 165 to the burners to be ignited by the pilot flame. At this stage, the slidable rod 160 is still maintained in the inward position by the electromagnetic safety device 176 so that gas continues to flow out of both the pilot orifice 164 and the outlet orifice 165. The valve 159 is turned off by de-energizing the electromagnetic safety device 176 so that the compression spring 177 returns the rubber washer 170 to the position pressing against the opening 171 and the compression spring 178 returns the rubber washer 175 to the position pressing against the opening 173, therefore, gas is prevented from flowing into the main chamber 172 and the outlet chamber 174. The advantages of this embodiment are that the force exerted on the seesaw bar 167 is counterbalanced and the distance for moving the slidable rods 160 and 161 is much smaller.

[0031] As best shown in FIG. 9 the seesaw bar 167 of the valve 159 may be operated by an electromagnet assembly 179 with seesaw bar 167 mounted in a pivotable manner to a supporting post 180. The electromagnet assembly 179 has an electromagnetic winding 181 wound on a mild steel core 182. A solenoid plunger 183 is slidably mounted within the core 182. The solenoid plunger 183 has a mild steel portion 184 surrounded by the electromagnetic winding 181 and a non-magnetic plunger arm 185 extending outwards to contact the seesaw bar 167. The electromagnet assembly 179 may be operated to pivot the seesaw bar 167 in a manner similar to that operated by the motor 166.

[0032] An electromagnetic device 186 as shown in FIG. 10 may be incorporated in the gas control valve 10 for operating the slidable rod 26 in an overriding manner. The electromagnetic device 186 has an electromagnetic winding 187 wound on a bobbin 188 located within a mild steel enclosure 189. A mild steel plunger 190 is slidably mounted within the electromagnetic device 186 and it is operative to move in a back and forth sliding movement by energizing

the electromagnetic winding 187. The plunger 190 has an arm 191 extending outward of the enclosure 189. The electromagnetic device 186 is mounted on the angle support 44 with the outer end portion of the slidable rod 26 slidably extending within the electromagnetic device 186 to engage with the plunger 190. Thus, the operation of the plunger 190 in the back and forth sliding movement will cause the slidable rod 26 to move in the similar manner to provide the functions of the valve 10 as described above. The arm 191 may also be operated manually to move the slidable rod 26 to provide the various functions.

[0033] The valve 10 can be disabled easily using a permanent magnet applied externally adjacent the electromagnetic control device 15 to hold the plunger 14 in an open position. Further modification of the system can include use of multiple pilot lights 77 with multiple thermocouples 80 to light multiple burners 63, 64 (as shown in FIG. 2) where the pilot lights 77 are supplied from a common gas manifold.

[0034] Although the above description relates to a specific preferred embodiment as presently contemplated by the inventor, it will be understood that the invention in its broad aspect includes mechanical and functional equivalents of the elements described herein.

I claim:

1. A gas control system comprising:
 - a valve body having a preliminary chamber,
 - an inlet orifice in communication with said preliminary chamber,
 - an outlet orifice on said valve body in communication with a gas burning device,
 - a main chamber within said valve body, said main chamber and said preliminary chamber communicating through a valve opening,
 - a stopper in said preliminary chamber and normally urged by a compression spring located in said preliminary chamber to engage with said valve opening to close communication between said preliminary chamber and said main chamber,
 - an elongated slidable rod slidably mounted in said valve body and having an inner end portion juxtaposed with said stopper washer, and
 - a pressing arm juxtaposed with another end of said slidable rod and operative for pressing said slidable arm inwards to disengage said stopper washer from said valve opening for releasing the gas in said preliminary chamber into said outlet orifice.
2. A gas control system according to claim 1 including a stepping motor mounted to said valve body, said pressing arm being mounted to a rotary shaft of said stepping motor whereby rotation of said motor pivots said pressing arm to press said slidable arm inwards of said valve body.
3. A gas control system according to claim 2 wherein said outlet orifice is connected to gas burners and pilot flame units.
4. A gas barbeque control system comprising:
 - a valve body having a preliminary chamber for receiving the gas for operating said barbeque,

- an inlet orifice provided on said valve body operative by an electromagnetic control member for admitting gas into said preliminary chamber;

- an outlet orifice provided on said valve body operative for directing the gas to gas burners in said barbeque from a main chamber in said valve;

- a pilot orifice provide on said valve body operative for directing the gas to flow to a pilot flame gas tube of said barbeque;

- a first valve opening located between said preliminary chamber and said pilot orifice; a first stopper washer located in said preliminary chamber and normally biased by a first compression spring to engage with said first valve opening; said electromagnetic control member being operative for disengaging said first stopper washer from said first opening whereby the gas in said preliminary chamber flows to said pilot flame gas tube through said pilot orifice.

5. A gas barbeque control system according to claim 3 including a second valve opening located between said preliminary chamber and said main chamber, an elongated slidable rod mounted in said valve body, a bushing mounted on said slidable rod and operative by said slidable rod to engage and disengage with said second valve opening selectively.

6. A gas barbeque control system according to claim 5 including a compression spring located in said main chamber and normally applying a spring force for urging said bushing towards said second valve opening.

7. A gas barbeque control system according to claim 6 including a pressing arm juxtaposed to an outer end of said slidable rod and operative for pressing said rod inwards to engage said bushing with said second valve opening.

8. A gas barbeque control system according to claim 7 including a ring washer fixedly mounted on a middle portion of said elongated slidable rod located within an inner chamber of said valve body, a second compression spring located in said inner chamber and cooperative with said ring washer and an end wall of said inner chamber for normally urging said slidable rod to extend outward of said valve body whereby disengaging said bushing from said second valve opening when said pressing arm is not pressing said rod inwards whereby gas in said preliminary chamber flows into said main chamber to exit said outlet orifice.

9. A gas barbeque control system according to claim 8 including a stepping motor mounted to said valve body, and said pressing arm is a pivotal arm having one end mounted to a rotary shaft of said stepping motor and a free end portion juxtaposed with said outer end of said slidable rod.

10. A gas barbeque control system according to claim 9 including a mechanical button mounted on said outer end of said slidable rod and operative manually for pressing said slidable rod inwards of said valve body.

11. A gas barbeque control system according to claim 9 wherein said pressing arm is a slidable plunger of an electromagnetic solenoid operative for pressing said slidable rod inwards of said valve body.

12. A gas barbeque control system according to claim 8 including a remote control system having a sensing and control unit mounted on said barbeque and a remote selection unit, said sensing and control unit and remote selection unit communicative with one another through a transmitter in each unit, said sensing and control unit having a tem-

perature sensor mounted on said barbeque, a comparator means operative for comparing electrical signal from said temperature sensor and from said stepping motor for providing a status signal indicative of temperature condition of said barbeque, said status signal being transmitted to said remote selection unit.

13. A gas barbeque control system according to claim 12 wherein said remote selection unit having a temperature setting means operative for generating a selection signal indicative of a desirable temperature of said barbeque, a second comparator means in said remote selection unit operative for comparing said selection signal with said status signal transmitted to said remote selection unit to generate a control signal transmitted back to said sensing and control unit for operating said pressing arm to press on said slidable rod in a selected manner to vary amount of said gas flowing through said second valve opening to said outlet orifice and in turn setting the degree of flame of said burners of said barbeque.

14. A gas barbeque control system according to claim 8 including a motor control device connected to said stepping motor and being operative for rotating in a clockwise direction and counterclockwise direction selectively for varying amount of said slidable rod pressing into said valve body for varying the amount of gas flowing to said burners of said barbeque.

15. A gas barbeque control system according to claim 8 wherein said pilot flame gas tube having pilot flame openings located adjacent to said gas burners, and sparker devices located adjacent to said pilot flame openings and being operative for igniting the gas emitting from said pilot flame openings.

16. A gas barbeque control system according to claim 15 wherein said motor control device is operated by batteries, and a low battery inhibitor is included therein to render said motor control device operative only when said batteries have sufficient power to operate said control system through a complete cycle.

17. A gas barbeque control system according to claim 1 wherein said valve body includes a first body portion and a second body portion, said inlet orifice and outlet orifice being provided in said first body portion and a pilot orifice provided in said second body portion, said preliminary chamber and said main chamber being located in said first body portion, and an intermediate chamber and pilot gas outlet chamber located in said second body portion, a first valve opening located between said preliminary chamber and said main chamber, and a second valve opening located between said intermediate chamber and pilot outlet chamber, a first spring biased valve seat located in said preliminary chamber and operative to close said first valve opening normally, a second spring biased valve seat located in said intermediate chamber and operative to close said second valve opening normally, a first elongated rod slidably mounted in said first body portion, and a second elongated rod slidably mounted in said second body portion,

a seesaw bar operative for pressing selectively said first elongated rod and said second elongated rod inward of said first body portion and second body portion respectively for opening said first valve opening and second valve opening whereby gas flow from said inlet orifice to said outlet orifice and said pilot outlet orifice.

18. A gas barbeque control system according to claim 15 including thermoelectric transducers mounted on said barbeque and operative for converting heat of said barbeque for operating electrical components of said control system.

19. A gas barbeque control system according to claim 18 including a light operative for illuminating the interior of said barbeque, and an imaging device mounted on a side wall of said barbeque and operative for generating an electronic image of said interior of said barbeque and transmitting said image to a display device for monitoring cooking condition of food in said interior.

* * * * *