

Dec. 4, 1923.

1,475,962

S. OLSON

TRANSFER DEVICE FOR CONVEYERS

Filed Sept. 9, 1922

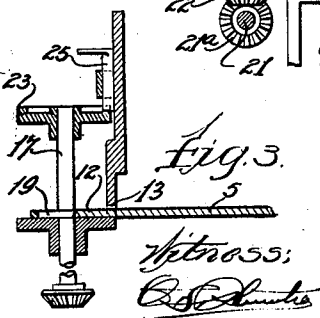
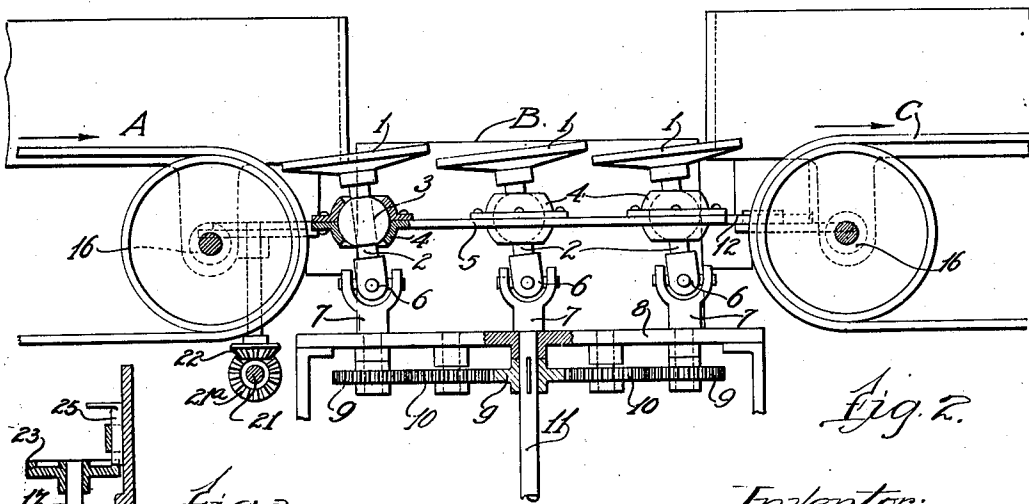
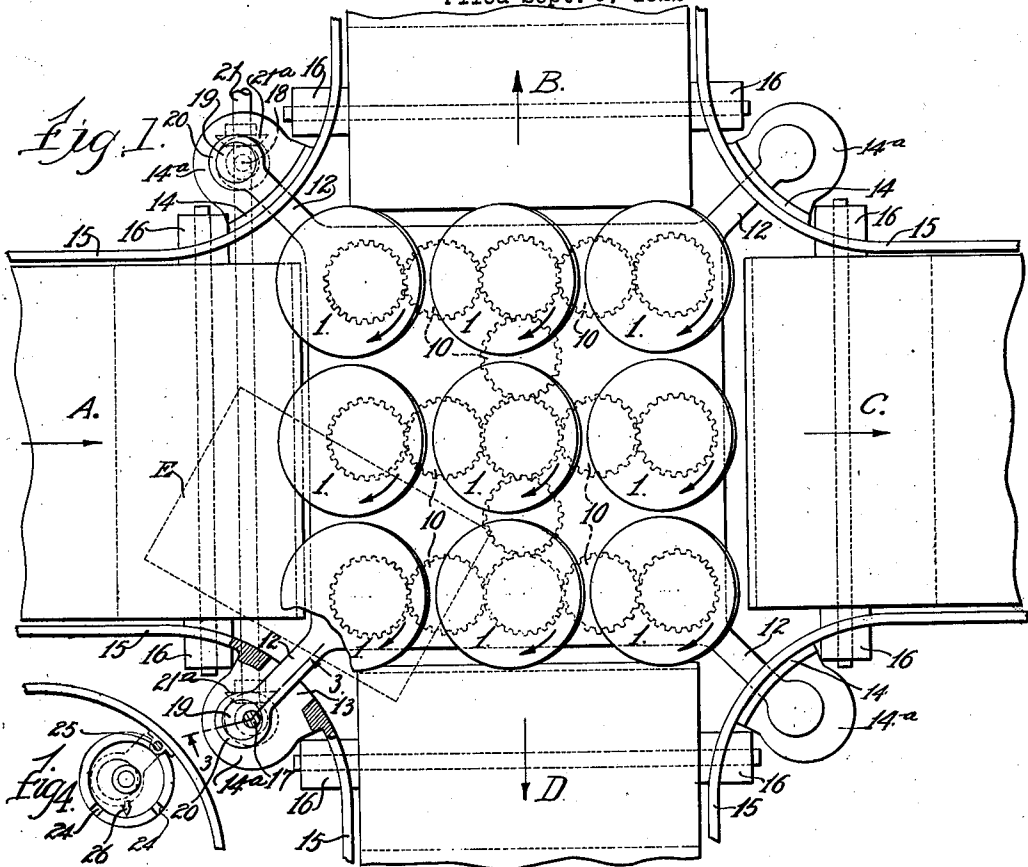

Inventor:  
 Samuel Olson,  
 by *Samuel Olson*  
 his Atty's.

Witness:  
*C. J. Adams*

# UNITED STATES PATENT OFFICE.

SAMUEL OLSON, OF CHICAGO, ILLINOIS, ASSIGNOR TO SAMUEL OLSON & COMPANY, OF CHICAGO, ILLINOIS, A CORPORATION OF ILLINOIS.

## TRANSFER DEVICE FOR CONVEYERS.

Application filed September 9, 1922. Serial No. 587,045.

*To all whom it may concern:*

Be it known that I, SAMUEL OLSON, a citizen of the United States, residing in the city of Chicago, county of Cook, and State of Illinois, have invented certain new and useful Improvements in Transfer Devices for Conveyers, of which the following is a specification, reference being had to the accompanying drawings, forming a part thereof.

This invention relates to conveyers of the type designed to carry loads principally in horizontal direction although it is applicable to conveyer systems in which the track consists of a succession of rollers arranged upon a slight incline so that gravity propels the loads. The invention is herein illustrated in connection with horizontally travelling belts which constitute moving floors or supports for loads. The purpose of the invention is to furnish means to facilitate the transfer of a load from one conveyer or track to another conveyer along which it shall move in a direction transverse to the direction travelled on the first conveyer; and the invention is further designed to provide such a transfer device in conjunction with conveyers leading to it and extending from it in several directions, together with means by which the transfer of a load may be effected from one of the conveyers to any of the others. It consists of certain features and elements of construction and their combination as hereinafter described and shown in the drawings and as indicated by the claims.

In the drawings:

Figure 1 is a top plan view of a transfer device embodying this invention showing also the terminal positions of several conveyers with which it is associated.

Figure 2 is principally a side elevation of the transfer device shown in Figure 1 with certain parts shown in section and with one of the conveyer terminals omitted to avoid obscuring the transfer elements.

Figure 3 is a detail section of the adjusting device taken as indicated at line 3—3 on Figure 1.

Figure 4 is a top plan view of an adjusting device omitted from Figure 1.

For purpose of illustration I have shown four bolt conveyers A, B, C and D respectively, which happen to be arranged at right angles to each other, with the transfer de-

vice which is the subject of this invention at their intersection. As indicated by the arrow the conveyer, A, moves toward this intersection while the arrows associated with each of the other conveyers, B, C and D indicate that they all travel away from the intersection. With this particular arrangement the conveyer, A, may be considered as the feeding conveyer and the function of the transfer device is to distribute loads to the receiving conveyers, B, C and D.

The transfer mechanism consists of a plurality of driving or feeding members in the form of disks, 1, all mounted to rotate about axes which are slightly inclined from the vertical so that the circular periphery of each disk, 1, is exposed upwardly and owing to the slight tilt or inclination of the disks, only a limited portion of each periphery extends as high as the common plane of the conveyer belts, A, B, C and D. The disks, 1, are sufficient in number, however, and are so arranged that these upper portions of their peripheries may support loads delivered from the conveyer belt A; and by rotating all the disks simultaneously in the same direction I make them serve as driving means for the load thus supported to propel it in the general direction of travel of these upwardly exposed peripheral portions of the disks.

For example, in Figure 1 a box is represented by the dotted outlines, E, as being just delivered from the conveyer belt, A, on to three of the disks, 1, at one corner of the transfer device. As viewed in the drawing the right edges of all the disks are uppermost and the disks travel in clockwise direction, therefore the tendency is for the box received to be fed toward the conveyer belt, D, while it is supported by the disks, 1, and as the leading corner of edge of the box, E, arrives on the belt, D, the motion of the latter will assist in completing the transfer.

As shown in Figure 2 each of the disks, 1, is mounted on a shaft, 2, having a spherical or globular enlargement, 3, journalled in a spherically formed bearing, 4. All the bearings, 4, are carried in a single plate or support, 5, for a purpose to be explained. At the lower end each shaft, 2, is connected by universal joint, 6, with a drive shaft, 7, journalled in a fixed support, 8, and carrying a gear, 9, at its lower end. By means of idler gears, 10, the gears, 9, are all con-

5 nected together to rotate in the same direction whenever motion is communicated to any one of them. The drawing shows a drive shaft, 11, connected directly to one of the gears, 9, for this purpose and this shaft will be continuously driven whenever the belts A, B, C and D are running though not necessarily in any particular speed relation to said belts.

10 Since the shafts, 2, are all connected to the drive shafts, 7, by universal couplings, 6, it is possible to vary the direction of inclination of the shafts, 2, without disturbing the drive relation. This is done by shifting the plate, 5, substantially in its own plane so that, for example, the left hand portions of the peripheries of the disks, 1, may be brought uppermost instead of right hand portions as shown in the drawings and thus the transfer device will be adjusted to deliver loads to the belt, B, instead to the belt, D. Or, if the shafts, 2, are tilted to bring uppermost the edges or the disk, 1, which are nearest the belt, B, disks will then serve to carry a load directly across to the conveyer belt, C.

For guiding the plate, 5, in such adjustment it is provided with arms, 12, extending from its four corners through guide slots or openings, 13, formed in brackets, 14, supported by the guide rails, 15, which are mounted adjacent the terminals of the belt conveyers and incidentally support bearings, 16; for the rollers or pulleys around which the belts travel. The end portions of the arms, 12, rest upon tablets, 14<sup>a</sup>, and in two of said tablets there are journalled vertical adjusting shafts, 17 and 18, each carrying an eccentric, 19. The ends of the arms, 12, are apertured to form eccentric straps, 20, and the shafts, 17 and 18, are connected by a cross shaft, 21, whose bevel gears, 21<sup>a</sup>, mesh with the gears, 22, on the lower ends of said shafts, 17, and 18, respectively. The shaft, 17, may be extended upward to any convenient height where it is provided with a hand wheel, 23, having notches, 24, in its rim to receive a locking dog, 25, for holding the parts at any definite position of adjustment. With this arrangement a single revolution of the wheel, 23, and its shaft, 18, causing one complete revolution of the eccentrics, 19, will shift the plate, 5, through its full range of adjustment, maintaining the axes of the shafts, 2, at all times parallel to each other. In this range three positions of adjustment are those in which the disks, 1, are so tilted as to deliver loads either to the belt, B, or to the belt, C, or to the belt, D, and the notches, 24, correspond to such positions. In addition a direction arrow, 26, may be marked upon the hand wheel, 23, to indicate the direction of travel which will be caused by a particular adjustment of the parts; as shown

in Figure 1 the arrow points in the direction of travel of the belt, D, to which, as already explained the disks, 1, will deliver the box, E, if adjusted as shown.

I claim:

1. In combination with a plurality of conveyers arranged with adjacent termini, a transfer device comprising a group of driving members interposed between said termini and all mounted to rotate about axes slightly inclined from strictly vertical direction for exposing upwardly a limited portion of the circular driving surface of each member which extends in a plane substantially perpendicular to the axis of rotation of the member.

2. In the combination defined in claim 1, said driving members being mounted to permit adjustment of their axes for exposing different portions of their circular driving surfaces at will to control the direction of a load supported and fed by said driving members.

3. In the combination defined in claim 1, said driving members being adjustable for positioning of their axes of rotation parallel to each other.

4. In the combination defined in claim 1, said driving members being adjustably mounted to permit changing the direction of inclination of their axes of rotation and controlling means for shifting said axes simultaneously.

5. In the combination defined in claim 1, inter-connected gearing arranged for driving all the driving members from a common source of power.

6. In the combination defined in claim 1, inter-connected gearing by which all the driving members of said group are connected for simultaneous rotation.

7. In the combination defined in claim 1, inter-connected gearing by which all the driving members of said group are connected for simultaneous rotation in the same direction.

8. In the combination defined in claim 1, each of said driving members comprising a shaft with a disk secured to its upper end extending in a plane perpendicular to the shaft axis.

9. In the combination defined in claim 1, each of said driving members including a shaft having a spherical portion disposed below the circular driving surface of the member and a spherical bearing above said portion to permit adjusting the direction of inclination of the shaft.

10. In the combination defined in claim 9, a universal drive coupling connected to the shaft of said driving member below said bearing, a power shaft and means operatively connecting said power shaft with the drive coupling.

11. In the combination defined in claim 9, 130

the spherical bearings for the entire group of driving members being rigidly connected together by a suitable carrier and means for adjusting the carrier transversely of the shaft axes for altering the direction of said axes at will.

12. In the combination defined in claim 11, the axes of the driving members extending parallel to each other and the range of adjustment of said bearing carrier being a circular orbit with means for controlling the carrier in its orbit to maintain the axes of the driving members in parallel relation throughout said range of adjustment.

13. In the combination defined in claim 11, said carrier having a pair of circular apertures fitted upon eccentrics connected for simultaneous adjustment about vertical axes and means for rotating said eccentrics to shift the carrier plate for alternating the direction of inclination of the driving members.

14. In combination with a feeding conveyer and a plurality of receiving conveyers arranged with their termini adjacent the

end of the feeding conveyer, a transfer device interposed between said conveyers comprising a group of driving disks all journaled to rotate about axes slightly inclined from vertical direction for exposing upwardly limited portions of their circular edges for driving engagement with loads discharged from the feeding conveyer, together with means for simultaneously shifting said driving members to vary their inclination and to change the portions of their driving edges which are upwardly exposed for contact with loads, and for thus selectively distributing such loads to the receiving conveyers.

15. In the combination defined in claim 14, indicating means associated with the means for shifting the driving members and adapted to show to which receiving conveyer the transfer device is adjusted to direct a load.

In testimony whereof, I have hereunto set my hand at Chicago, Illinois, this 17th day of February, 1922.

SAMUEL OLSON.