

(No Model.)

E. J. REED.

11 Sheets—Sheet 1.

BUOYANT SUBAQUEOUS TUNNEL FOR RAILWAYS, &c.

No. 408,748.

Patented Aug. 13, 1889.

Fig. 1

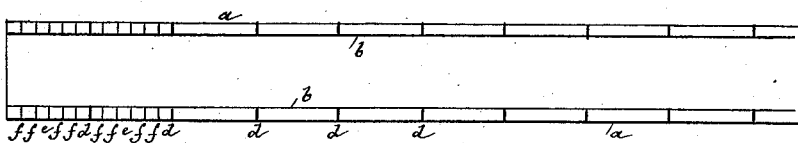
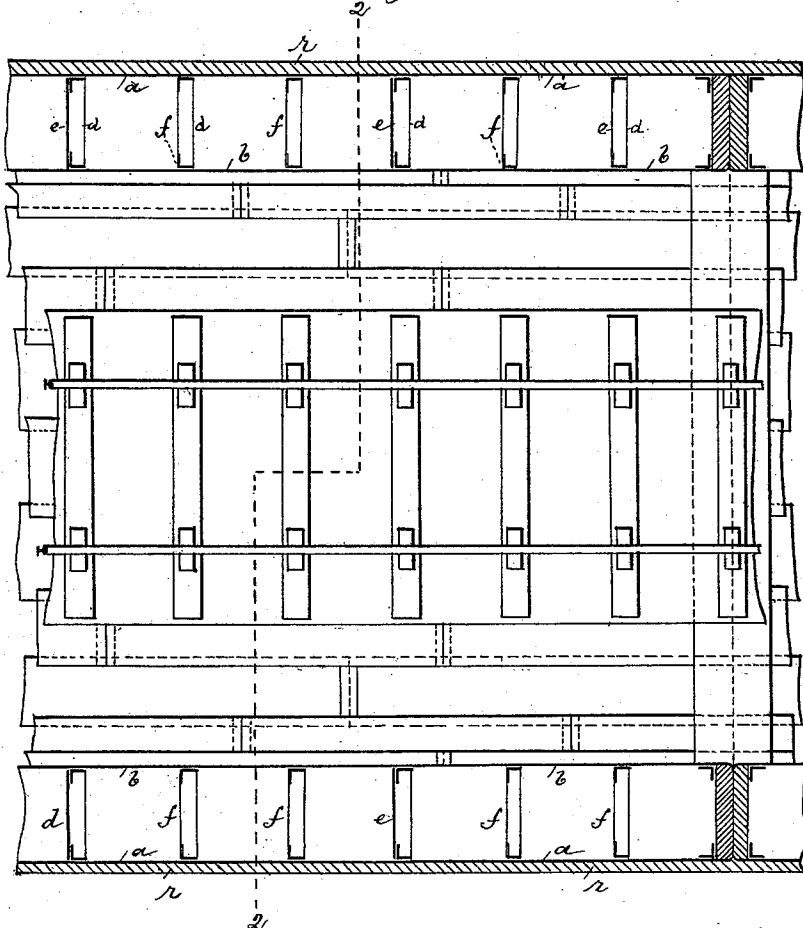

Fig. 4



WITNESSES:

E. B. Bolton
J. B. Spaulding

INVENTOR:

Edward J. Reed
 By his Atty.
Henry Conner

(No Model.)

11 Sheets—Sheet 2.

E. J. REED.

BUOYANT SUBAQUEOUS TUNNEL FOR RAILWAYS, &c.

No. 408,748.

Patented Aug. 13, 1889.

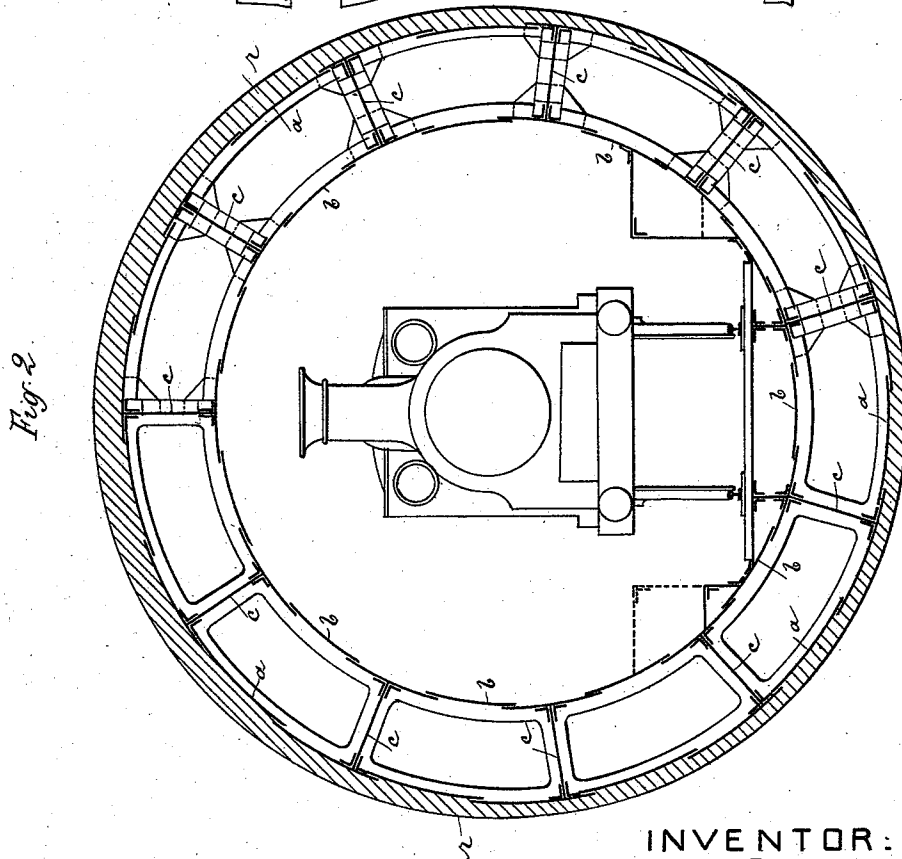
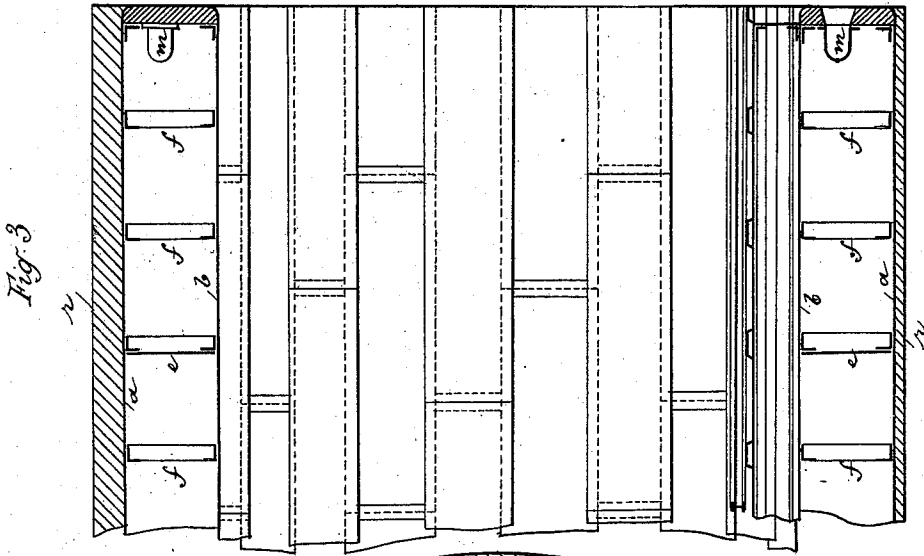

WITNESSES:

E. B. Bolton
H. C. Caplinger

INVENTOR:

Edward J. Reed
By his Atty-
Henry Council

E. J. REED.

BUOYANT SUBAQUEOUS TUNNEL FOR RAILWAYS, &c.

No. 408,748.

Patented Aug. 13, 1889.

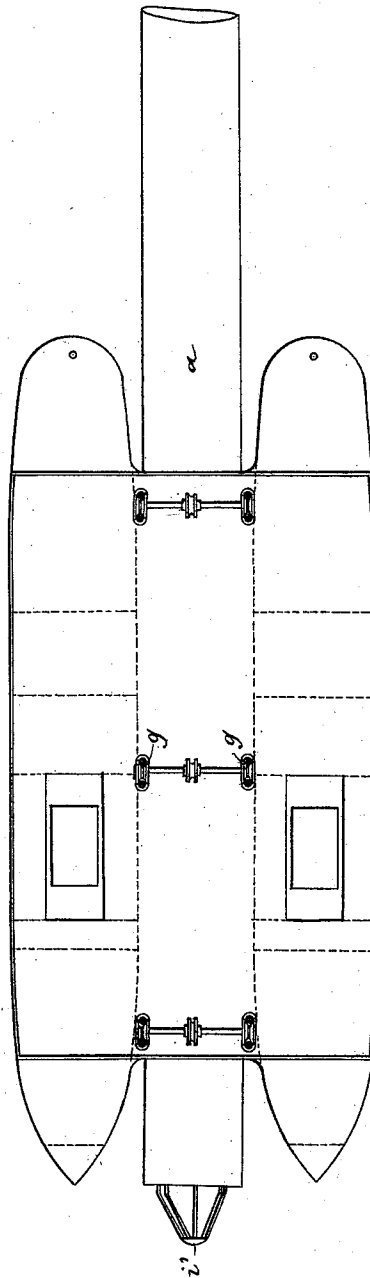
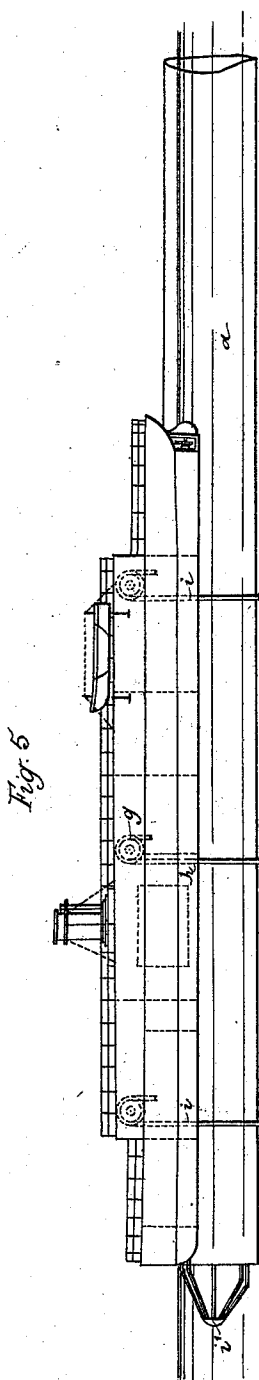

WITNESSES:

E. B. Bolton
J. H. Waplinger.

INVENTOR:

Edward J. Reed
 By his Atty.
Henry Combs

E. J. REED.

BUOYANT SUBAQUEOUS TUNNEL FOR RAILWAYS, &c.

No. 408,748.

Patented Aug. 13, 1889.

Fig. 8

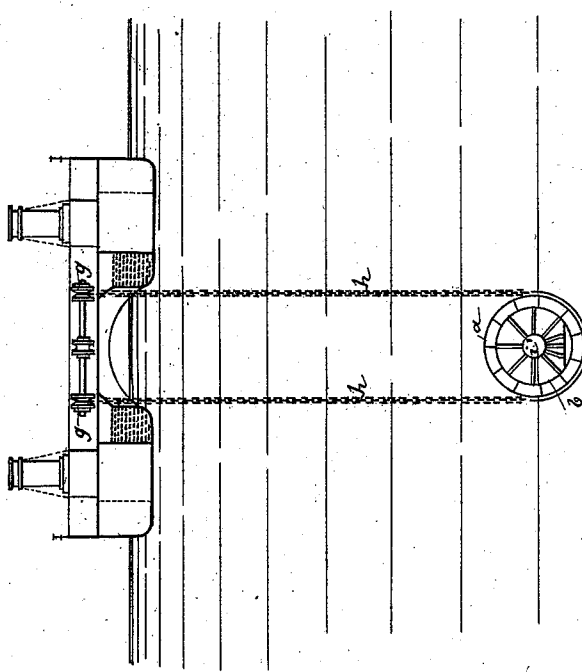
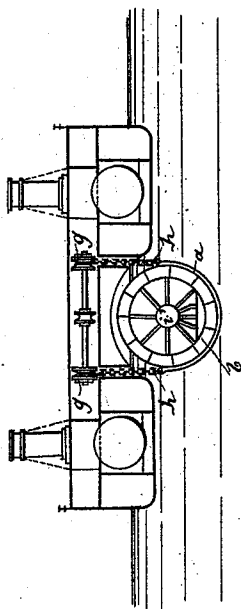

Fig. 6



WITNESSES:

E. B. Bolton
J. H. Barlingen

INVENTOR:

Edward J. Reed
By his Atty -
Harry Conner

E. J. REED.

BUOYANT SUBAQUEOUS TUNNEL FOR RAILWAYS, &c.

No. 408,748.

Patented Aug. 13, 1889.

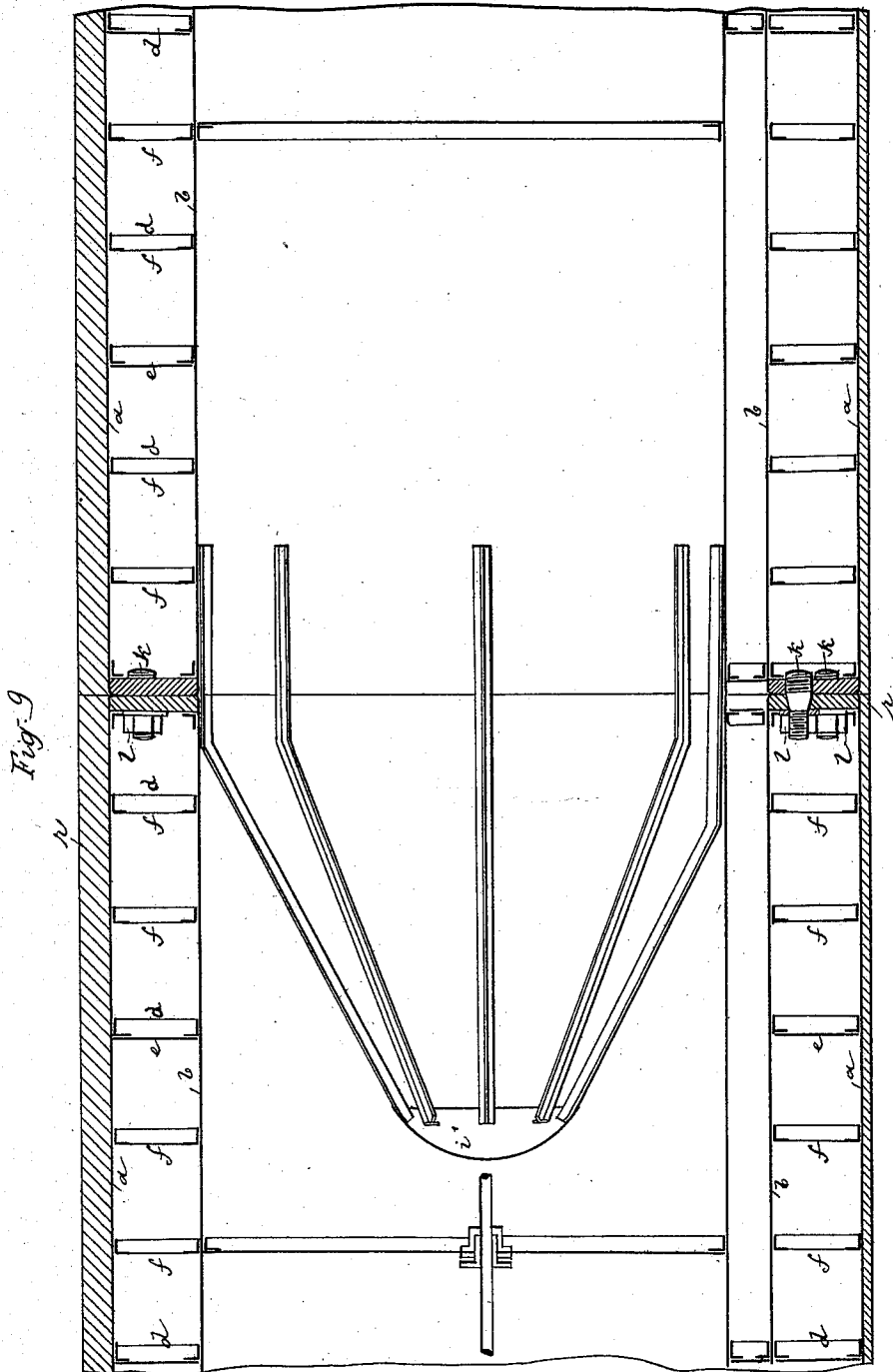

WITNESSES:

E. B. Bolton
J. H. Caplinger

INVENTOR:

Edward J. Reed
By his Atty.
Henry Conner

E. J. REED.

BUOYANT SUBAQUEOUS TUNNEL FOR RAILWAYS, &c.

No. 408,748.

Patented Aug. 13, 1889.

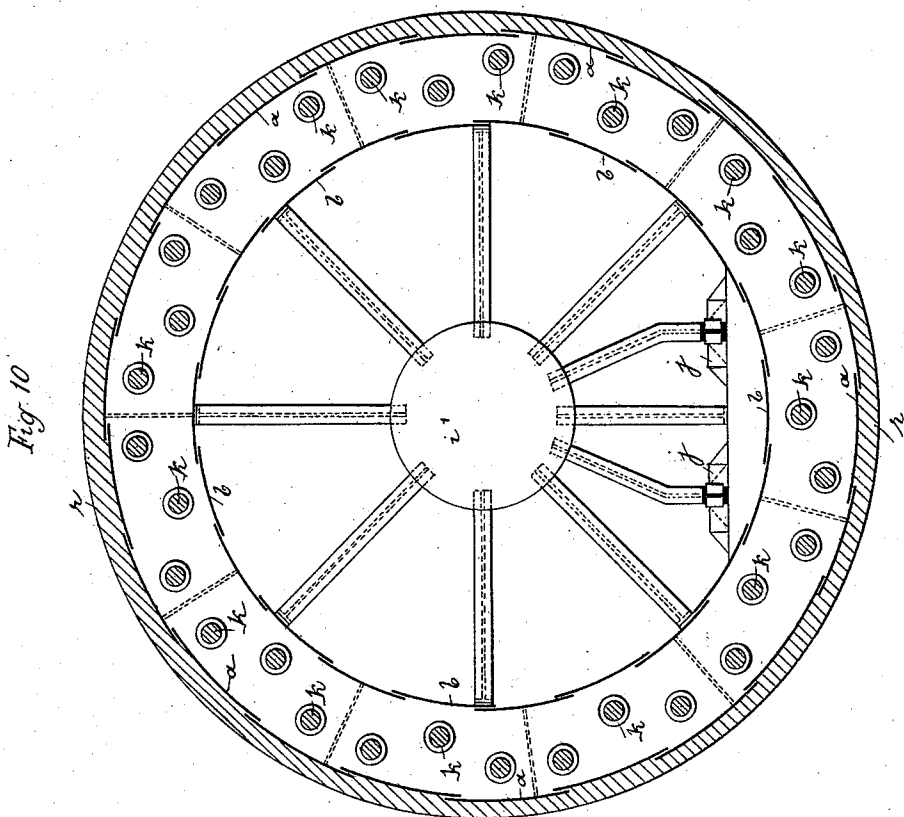

WITNESSES:

E. R. Bolton
J. B. Springer.

INVENTOR:

Edward J. Reed
By his Atty -
Henry Comstock

E. J. REED.

BUOYANT SUBAQUEOUS TUNNEL FOR RAILWAYS, &c.

No. 408,748.

Patented Aug. 13, 1889.

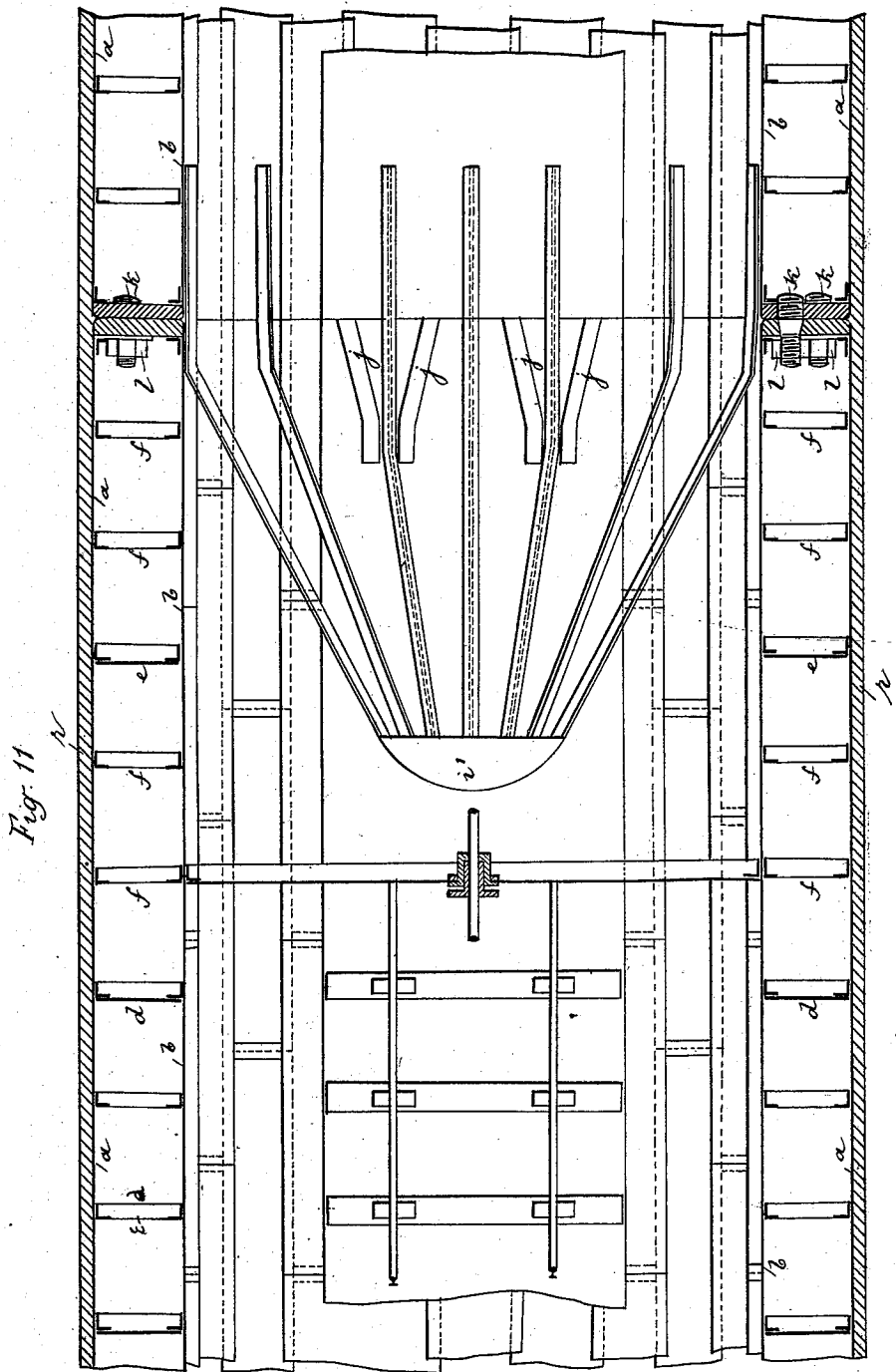

WITNESSES:

E. B. Bolton
J. H. Caplinger

INVENTOR:

Edward J. Reed
By his Atty.
Henry Comstock

E. J. REED.

BUOYANT SUBAQUEOUS TUNNEL FOR RAILWAYS, &c.

No. 408,748.

Patented Aug. 13, 1889.

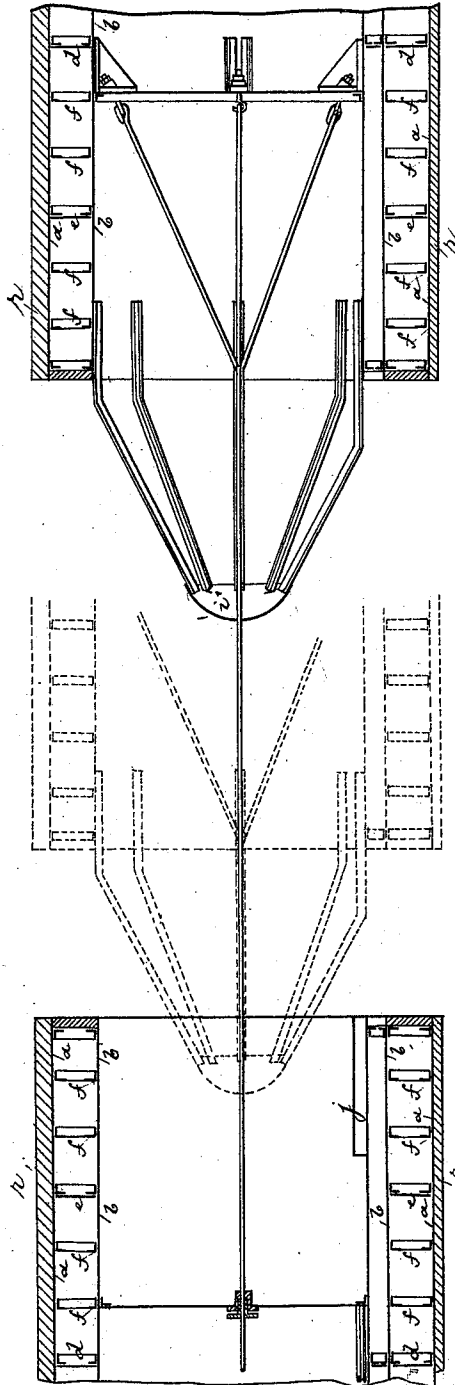

Fig. 12.

WITNESSES:

E. B. Bolton
H. Caplinger

INVENTOR:

Edward J. Reed
By his Atty.
Henry Curcio

(No Model.)

11 Sheets—Sheet 9.

E. J. REED.

BUOYANT SUBAQUEOUS TUNNEL FOR RAILWAYS, &c.

No. 408,748.

Patented Aug. 13, 1889.

Fig. 14

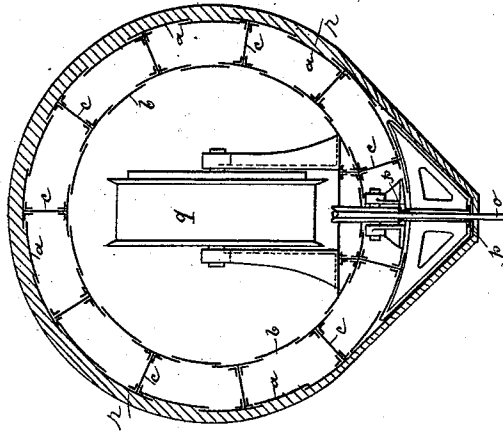
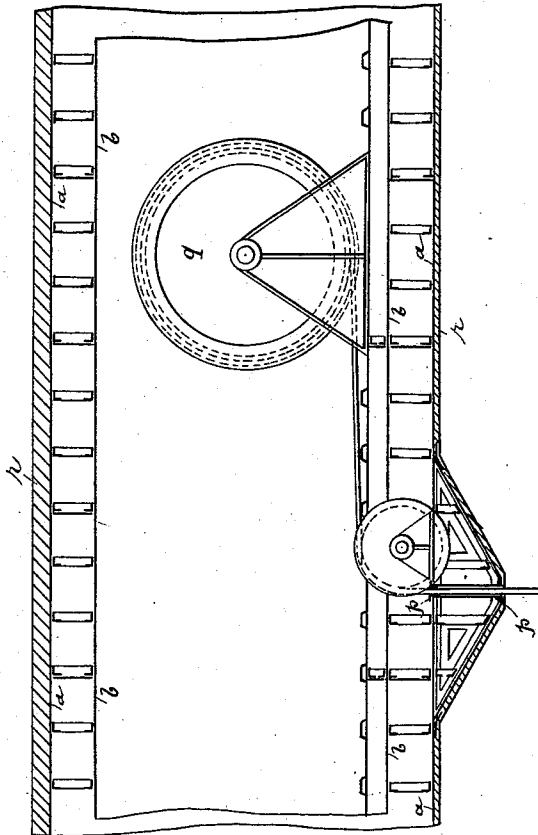

Fig. 13



WITNESSES:

E. B. Bolton
H. Caplinger

INVENTOR:

Edward J. Reed
By his Atty-
Henry Combs

(No Model.)

11 Sheets—Sheet 10.

E. J. REED.

BUOYANT SUBAQUEOUS TUNNEL FOR RAILWAYS, &c.

No. 408,748.

Patented Aug. 13, 1889.

Fig. 15

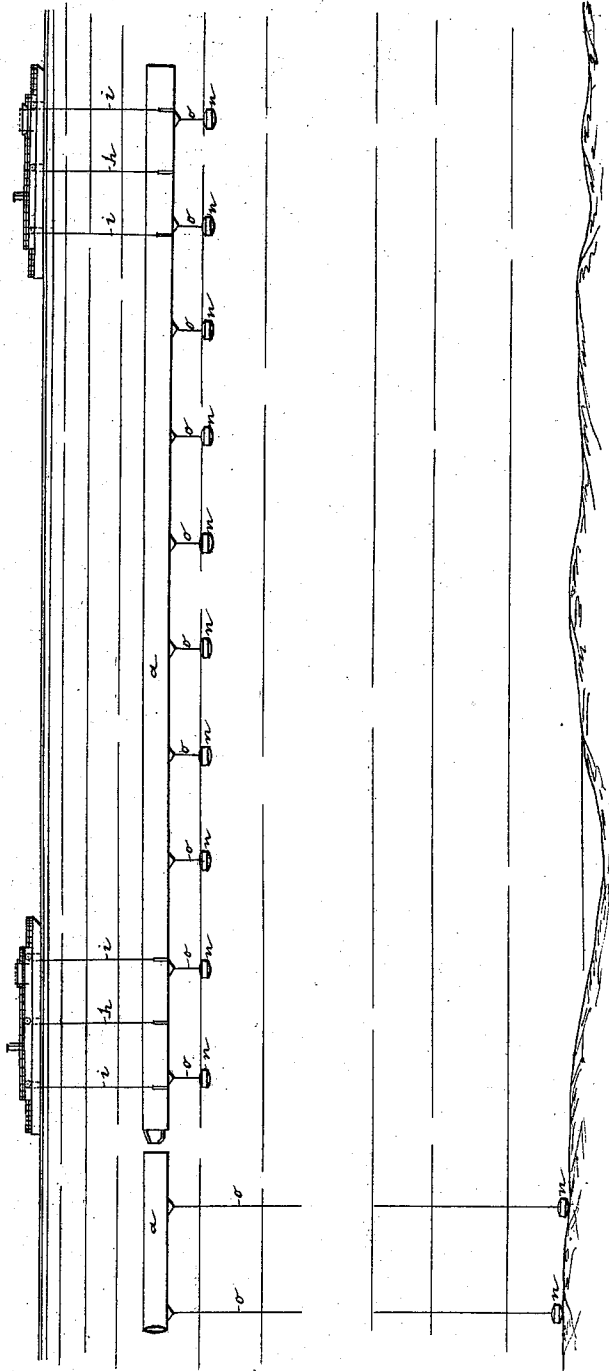

WITNESSES:

E. B. Bolton
J. H. Caspinger

INVENTOR:

Edward J. Reed
By his Atty-
Henry Connors

(No Model.)

11 Sheets—Sheet 11.

E. J. REED.

BUOYANT SUBAQUEOUS TUNNEL FOR RAILWAYS, &c.

No. 408,748.

Patented Aug. 13, 1889.

Fig: 16.

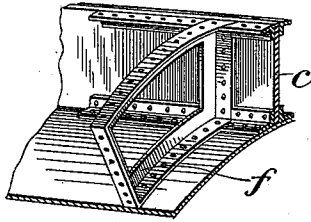

Fig: 17.

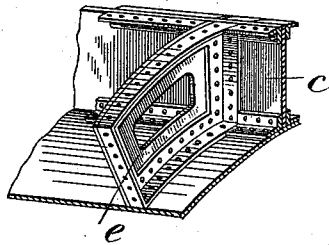
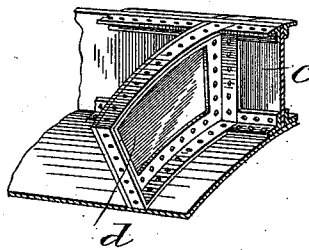

Fig: 18.



INVENTOR:

Edward J. Reed,

WITNESSES:

John J. Kennid
J. S. Caplinger

By *Henry Commins*
Attorney.

UNITED STATES PATENT OFFICE.

EDWARD J. REED, OF LONDON, ENGLAND.

BUOYANT SUBAQUEOUS TUNNEL FOR RAILWAYS, &c.

SPECIFICATION forming part of Letters Patent No. 408,748, dated August 13, 1889.

Application filed December 13, 1886. Serial No. 221,376. (No model.) Patented in England July 23, 1886, No. 9,558; in France October 21, 1886, No. 179,166; in Belgium October 26, 1886, No. 74,995; in Germany October 26, 1886, No. 41,263; in Denmark November 6, 1886; in Spain November 26, 1886, No. 6,383; in Canada March 10, 1887, No. 26,192, and in Italy March 31, 1887, XX, 20,696, XLII, 155.

To all whom it may concern:

Be it known that I, EDWARD JAMES REED, K. C. B., a subject of the Queen of Great Britain, and a resident of London, England, have invented certain Improvements in Buoyant Subaqueous Tunnels for Railways, &c., (for which patents have been granted in England July 23, 1886, No. 9,558; in France October 21, 1886, No. 179,166; in Belgium October 26, 1886, No. 74,995; in Germany October 26, 1886, No. 41,263; in Spain November 26, 1886, No. 6,383; in Canada March 10, 1887, No. 26,192; in Denmark November 6, 1886, (no number,) and in Italy March 31, 1887, R. G. XX, 20,696, R. A. XLII, 155,) of which the following is a specification.

My invention relates to that class of tunnels which are suspended in the water by their own buoyancy and anchored to maintain them in position; and the object of the invention is to improve the construction of a tunnel of this character with a view of imparting to it strength and durability, to protect it against injury from collisions, and to facilitate the building and anchoring of the same.

I employ in the construction of my tunnel tubes more or less buoyant and of peculiar construction, by preference formed in whole or in part of iron or steel, these tubes or constructions supported wholly or in the main by the water of the water-way in which they are placed; and said tubes or constructions need not ordinarily be submerged, except to a depth sufficient for them to clear the bottoms of vessels of the deepest draft, which depth may be marked or indicated at the point of crossing. Such a tube or construction connects the opposite margins or banks of the water-way, in which there are not tides nor currents, situated at a depth of thirteen meters, for example, below the surface of the water, and is fixed at its ends in a stanch or water-tight manner in tunnels or trenches in the earth, closed at one end or the other. This tube will serve perfectly for the passage of trains, provided the dimensions and strength of the tube shall be sufficient to resist the

tendency to depression or flexure which will be caused by the weight of the train in passing through the same. If the tube is supported at its extremities and has sufficient strength to bear the weight without producing flexure, there is no great difficulty. If the water of the water-way is always calm and without a tide and is not used for navigation, such a tube or construction, once in place, may with advantage, if of considerable length, be sustained by buoyant floats. These floats may have dimensions and be in number sufficient to relieve the tube in the main from the flexing or depressing tendency of a train passing through the same. Under certain suitable conditions I propose sometimes to carry out my invention by the above means. On the other hand, when the conditions are the same as above stated, except that the water-way is to be left open to navigation of such a kind that the presence of numerous floating bodies would be troublesome, the tube or construction may be placed at a proper depth below the level of the waters in which the boats float, and one may then have recourse to inverse means—that is to say, the tube is made buoyant to excess, and is drawn and held down by a suitable number of anchors or other attachments to the bottom of the water-way. The excess of buoyant upward pressure that the tube itself experiences at all points, or at different parts of its length, will relieve the tube of the whole or a part of the strain from the weight of a passing train. I propose sometimes to carry out my invention in this manner.

In places where the water-way to be crossed is wide, and where the tube or hollow construction must in consequence have great length, and in places where, beyond this, there are tides or currents to encounter, the placing and fixing of such a tube or construction necessitates numerous arrangements for their sure, efficacious, and durable execution. In order to properly handle the tube or the large sections thereof when brought to the place the tube is to occupy, I

sometimes attach to the tube, (besides the floats, tow-boats, and other ordinary contrivances,) or I construct in one with it, but in such a manner as to be separated therefrom when necessary, a float or buoy in the form of a boat or ponton, or several of these boats furnished each with steam motive power and engines for handling it, constructed and situated in such a manner as to maintain the tube at the desired distance below the surface of the water and to regulate its movements while it is being placed in position. To resist the perturbing effects of tides or currents, I propose to anchor the tube at intervals, not only vertically but laterally, and to furnish the tube with all the frame-work and all the arrangements necessary for bringing the anchors, cables, &c., into their proper positions and for resistance to future strains.

It is hardly necessary for me to say that the tube should be formed and constructed in such a manner as to be very strong and to possess an exceptionally great ability to resist all the efforts or strains that may be exercised on it or brought to bear on it, not only when it is new, but when it shall have suffered from inevitable corrosion and other deteriorations to which it will be submitted during its submersion for the predetermined period of its duration or life-time.

The vertical upward buoyant strain or pressure to which the tube is submitted should be great enough to compensate for the increase of weight due to accumulations of vegetation and marine incrustations which will form on the tube, cables, &c. It is evident that this end can be perfectly attained by making the tube sufficiently large to secure an initial supplementary buoyant upward pressure, which may be resisted by the corresponding anchors.

In applying my invention to straits and rivers open to navigation of importance I propose to cover the upper parts and partially also the sides of the tube with solid *béton* or concrete, or with other suitable material, to prevent all damage from an anchor that may be let fall on it by accident or damage that may arise from any other analogous cause, and to take all other necessary or practicable precautions against all possible sources of damage or perturbation. As a large tube constructed of iron or steel, although constructed of very great strength for the motives stated above, should have, nevertheless, a very considerable supplementary upward buoyant pressure, the execution of all the labors precedent will present no difficulty.

When I construct the tube or tubular way entirely or mainly of iron or steel, I ordinarily prefer to construct it with a stanch or tight interior tube, dividing the space between it and the exterior tube into a number of stanch or tight compartments. In certain cases, when the circumstances will permit, I prefer to establish a connection between the tube and the bottom of the water-way at in-

tervals and in suitable positions. In other cases I build the tube by successive steps out from one or both edges of the water-way, employing tight caissons constructed and arranged expressly for the purpose.

In order that my invention may be well understood and put in practice, I will now describe one means of carrying it out.

I will choose, for example, the case of a tube to be placed across a lake or strait at a considerable depth below the surface and under conditions which render desirable the placing of the tube in position in several lengths or sections—say, for example, each of about three hundred and fifty meters in length. The tube is in this case supposed to be constructed for a single-track railway, and being subject to a very great supplementary buoyant push or pressure it is held in position by a suitable number of anchors.

In order that the description may be the better understood, reference may be had to the accompanying drawings, wherein—

Figure 1 is a longitudinal axial section of the tube on a small scale. This view is somewhat diagrammatic and does not show all of the details. Fig. 2 is a transverse section of the tube on a large scale in the plane indicated by line 2 2 in Fig. 4. Fig. 3 is a vertical axial section of a part of the tube, showing the construction at the end of the tube-section. Fig. 4 is a horizontal axial section of a fragment of the tube on the same scale as Figs. 1 and 2, and showing the railway therein in place. Figs. 5, 6, 7, and 8 are views on a smaller scale, showing the boat and other means employed in transporting the section of the tube and placing it in position. Fig. 9 is a vertical axial sectional view of the abutting ends of two sections of the tube on the same scale as Figs. 2, 3, and 4. This view illustrates the centering-guides and securing devices. Fig. 10 is an end view of the tube seen at the right in Fig. 9, and is on the same scale as the latter figure. In this view the connecting-bolts and the concrete covering of the tube are represented in section. Fig. 11 is a horizontal axial section of the abutting ends of the tubes on the same scale as Figs. 9 and 10. Fig. 12 is a sectional elevation on a somewhat smaller scale than Figs. 9, 10, and 11, illustrating the manner of bringing together and centering the sections of the tube. Figs. 13 and 14 are respectively a sectional elevation and a transverse section of the tube on the same scale as Fig. 12, and showing the winding apparatus in the tube. Fig. 15 is a view on a small scale, illustrating the manner of anchoring the tube. Figs. 16, 17, and 18 are fragmentary views, on a large scale, illustrating the construction. These will be described hereinafter.

One of the sections or lengths, three hundred and fifty meters in length, hereinbefore referred to, is shown on a small scale in Fig. 1, and in this figure are indicated the transverse partitions and the frame-work between the

two tubes, which I will now explain. This tube is seen on a much larger scale in transverse section in Fig. 2, in sectional elevation in Fig. 3, and in sectional plan or horizontal section in Fig. 4. The tube is double, being composed of the exterior tube *a* and the interior tube *b*, the space between them being divided into tight compartments by longitudinal partitions *c* and the water-tight transverse partition *d*. Besides these tight partitions *d*, there are intermediate plates *e*, which are not tight, but have openings or apertures in them to lessen their weight, and iron corner or angle frame *s f*. Figs. 16, 17, and 18 illustrate this construction on a larger scale. Fig. 16 represents the partition formed of angle-frames *f*. Fig. 17 illustrates the partition made up of open plates *e*, and Fig. 18 represents the tight partition *d*. The tube is covered with Portland cement or other suitable material, which is thickest on the upper part of the tube for protection of the tube against injury that may result from the falling of an anchor thereon or from other causes.

Assuming that the extreme section of the tube fixed to the earth is placed and anchored and we wish to attach to it another section, I employ for this purpose, in the present case, two "placing-steamboats" with double hulls, furnished with good propelling or propulsive power and with a steam-capstan, for purposes that will be explained. The tube or tube-section to be placed in position is brought into deep water, and it carries its weight of anchors, chains, &c., and ballast, this latter being sufficient to sink the tube nearly down to the surface of the water, but with a little of its upper part above the water-level. This permits the placing-boats to be arranged over or astride the tube in its state of partial immersion. When they are thus placed, the cables, which have been passed under the tubes, are attached at the edges of the boats by means of strong steam-winchies, as seen in Figs. 5, 6, and 7, which are respectively a side view, an end view, and a plan. The tube may be thus maintained, either to be brought by the boats very near to its proper and final position and there lowered, the extremity of the tube being held at some meters from the end of the tube already in place, or it may be first lowered, as seen in Fig. 8, and afterward towed into position. The lowering is effected by the admission into the tight compartments of the tube of water sufficient to entirely submerge the tube and give it a tendency to sink to the bottom, the steam-winchies *g g* lowering it gradually by means of cables *h h* to the prescribed depth, which will have been carefully determined. There are two auxiliary cables *i i*, which support the tube from each boat, as seen in Figs. 5 and 7, to serve as checks or stops to prevent any injury that may result from an accident or from an error in the employment of the principal lowering-cables *h h*. These dispositions assure the tube being properly brought and

lowered to its position and depth desired, or approximately thereto.

To move laterally the tube that has been lowered, and thus bring it exactly facing or coincident with the tube-section already in position, I employ anchors carried by auxiliary boats to a considerable distance from the placing-boats at either side, and afterward lowered to the bottom, their cables passing around steam-capstans disposed for this purpose in said placing-boats. The precise position to be given to the tube will be indicated by marks placed on the shore, and by hauling in on the anchor-cables arranged on one side of the placing-boats and relaxing or slacking those on the opposite side until the submerged tube shall be in line with the marks on the shore the tube will be brought to its exact position laterally. It is only necessary now to advance the tube in the direction of its axis until it encounters the extremity of the tube already in position, and then to secure the two together.

To prevent injury or derangement from the shock of one tube against the other, I take care, as before explained, to arrest the tube that is being moved at a short distance from the other while the placing-boats are advancing into position. Now in order to bring the tube being moved into its exact position I employ the following-described means, observing that at this moment the principal interior spaces or hollows of the tubes are closed against the water by tight partitions placed at some meters from their ends. On the moving section or length of tube that is being put in position I have previously constructed a nose or conical appendage or conoid *i'*, to enter into the adjacent or fixed tube and guide the tube proper into its correct position. The moving tube or section may slightly deviate from the vertical position. I also furnish the two lengths or sections of the tube with horizontal guides *j j*, to correct this slight deviation. The guides *i'* and *j* are best shown in Figs. 9, 10, and 11, which are respectively a sectional elevation, an end elevation, and a sectional plan of the extremities of the two sections or lengths of the tube supposed to be brought together and connected. Fig. 12 shows the section of the tube being moved into place in two different positions, (one position being indicated by dotted lines,) which positions it successively assumes as the section is advanced to position. This drawing of the tube into place is effected by the following-described means: A steel cable passes through the stuffing-box arranged in the partition in the fixed section of the tube. The outer end of this cable is sustained or buoyed at the surface of the water, and the inner end is led through the tube to the shore, where a steam-engine and a powerful hydraulic machine are installed. A similar steel cable is attached rigidly to the moving tube-section by passing said cable through the cone *i'*, and its other end passes to the placing or conduct-

ing boat. When the moving tube-section is brought into place, the two cables are connected, the buoys supporting that first mentioned being removed. The machine on the shore then winds up the slack of the cable and draws it taut. The end of the cable on shore is then brought to the hydraulic machine, and the moving section of the tube is thus brought into perfect contact with the tube already in place, the guide i' and j, j assuring precision and exact correspondence. I would observe that the ends of the tube-sections, with all their attachments, must be primarily constructed and adjusted with the greatest care, one face or end with reference to that to which it is to be joined, before the tube-sections are placed in the water or submerged. The attachments consist of a series of bolts k, k . (Seen in Figs. 9 and 10.) These bolts are fixed firmly, by screwing or otherwise, to the face-plate of the moving tube-section, which is quite thick, and they are formed with conical shoulders, so as to the better enter the holes (also coned) in the face-plate of the fixed tube-section. Beyond these shoulders the bolts have screw-threaded extremities, upon which are screwed the nuts l, l . This construction has for its effect that each bolt when it enters the conical hole in the other face-plate serves as a supplementary guide to insure the exact adjustment of one face-plate to the other. To prevent the water from entering at the conical holes in the face-plate, metal caps m, m are arranged as seen in Fig. 3, these caps being removed when the two face-plates have been brought tightly together, the screws k being then in place and the holes stopped. The nuts are then screwed on and the joints made tight.

In order to get at the ends of the screws k for the purpose of removing the caps m and applying and screwing up the nuts l , the workmen obtain access to the annular space between the outer and inner tube-walls of the section previously fixed in position at a point where the tube is free from water through water-tight man-holes in the inner tube-wall.

In the case just described I effect the direct anchorage of the tube by the following-described means: The anchors (employed for the vertical anchorage) are only heavy masses or weights n, n , Fig. 15, and not anchors like those employed by ships, and each of them is attached to a steel or iron cable of suitable construction. Before the tube has been taken up by the placing-boats to be put into position each anchor-weight n is attached to a cable o of a length (determined by sounding) approximately equal to the depth of water below the tube when the latter is in place. This cable passes through a stuffing-box p in the bottom or attached to the bottom of the inner tube, and is wound on a large barrel q , placed for the time in the tube and controlled by powerful hydraulic brakes. As soon as the tube-section is placed in its proper position and secured to its adjacent section, the water about

the cone or guide i' is free to flow into the hollow of the fixed tube-section, (whence it is expelled or pumped out at the shore,) and tight doors which have been constructed in the temporary partitions are opened for the passage of the workmen into the newly-attached tube-section. These workmen lower each of the anchor-weights to the bottom. This done, each anchor-cable is gripped mechanically before its ends can escape, and the ends of the cables inside the tube are strongly and firmly attached in a permanent manner. Sometimes I effect this anchoring in part or principally by the means stated, and augment this by other weights connected by an anchor-cable, one of such weights (of each pair) being lowered to the bottom and the other simply lowered on the opposite side of the tube until the cable is tense in a transverse sense. In certain cases I adopt a similar arrangement to this latter; but I pass the cable over a pulley or sheave of brass or other material not likely to be injured by the water. The first part of the preceding anchor dispositions or arrangements, which is all that requires illustration, is represented in Figs. 13 and 14, of which the first is a side elevation and the latter an end view. Fig. 15 is a view of a length or section of the tube supported by the placing-boats.

At points where it is necessary, by reason of currents or for other causes, to anchor the tube laterally, I propose to transport by boats, to positions at some distance away on each side of the tube, anchors of the usual kind, and to lower them to the bottom at the proper points. As many anchors will be thus placed as may be found necessary by calculation. The cables of these anchors will be drawn taut by means of steam or hydraulic capstans, either placed in the tube or on the shore. The anchor-cables pass into the tube through stuffing-boxes, and when they are drawn or strained taut they will be fixed or secured in a permanent manner.

In certain cases I propose, when the circumstances will permit and the length of the tube is not too great, to construct the tube in a single length and in a curved form, the curvature being horizontal when the tube is in process of construction, the finished tube being put into position in the manner following: The ends of the tube are brought to their places at or near the shore and the water let into the tight compartments at or near the central part of the tube, thus causing this part to sink until the tube is put in the desired position, with its ends either raised above the water or otherwise, as may be preferred, the connections with the shore being afterward completed.

In other cases I commence a length or section of tube on inclined ways, lowering it into the water (at a point where it is tranquil and with little or no current) from time to time as it is extended by additions to its length, continuing to build toward the shore

after each launching until all of the tube or a length determined upon shall be completed, being careful to charge the immersed end with water or ballast in such a manner as to always maintain as nearly as possible a uniform depth of immersion. In general, I prefer, however, to construct my tube in sections or lengths and launch these separately, allowing them to float in the water and afterward to assemble and connect these sections, as described.

Having thus described my invention, I claim—

1. The combination, with the two sheet-metal tubes *a* and *b*, arranged concentrically, of the tight partitions *c*, extending longitudinally, the apertured transverse partitions *e*, the water-tight transverse partitions *d*, and the angle-irons *f*, all arranged within the annular space between tubes *a* and *b* and connecting the latter, as set forth.

2. The tube-section having tight partitions near its ends to prevent the entry of water into its interior, and having at one end a conical projection or nose, as *i'*, to enable said tube to be axially aligned with the adjacent section while submerged.

3. The tube-section having at one end a

projecting conical nose *i'* for axially aligning it with the adjacent section, and having at its other end guides *j j* to effect the proper coincidence of the bolt-holes in the two sections, substantially as set forth.

4. In a subaqueous tunnel, the combination of two tube-sections, one of which is provided with conical bolt-holes and the other with conical bolts *k k*, secured in the said section in position to engage said bolt-holes in the abutting or adjacent section, as set forth.

5. The combination, with the tube provided with windlasses or winding apparatuses in its interior and with stuffing-boxes in its bottom for the passage of chains, of the said chains, connected each to the barrels of one of said windlasses and passing out through said stuffing-boxes, and anchor-weights, one connected to each chain, substantially as set forth.

In witness whereof I have hereunto signed my name in the presence of two subscribing witnesses.

EDWARD J. REED.

Witnesses:

FRANÇOIS DELONELY,
ALFRED MATTE.