

L. D. ROBERTS.
Horseshoe-Machine.

No. 101,513.

Patented Apr. 5, 1870.

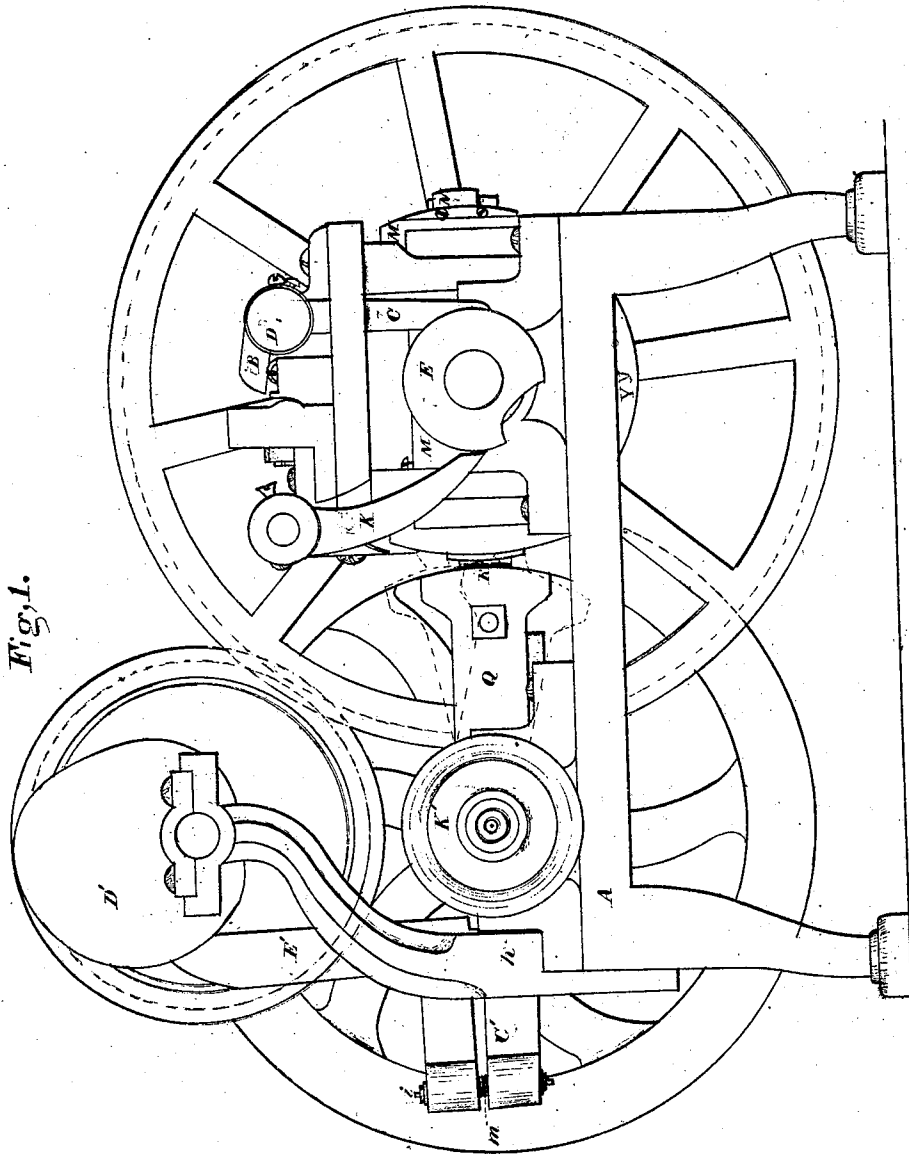

Fig. 1.

Inventor.
L. D. Roberts
Per. Burridge & Co.

Witnesses,
J. H. Burridge
D. B. Humphrey

L. D. ROBERTS.
Horseshoe-Machine.

No. 101,513.

Patented Apr. 5, 1870.

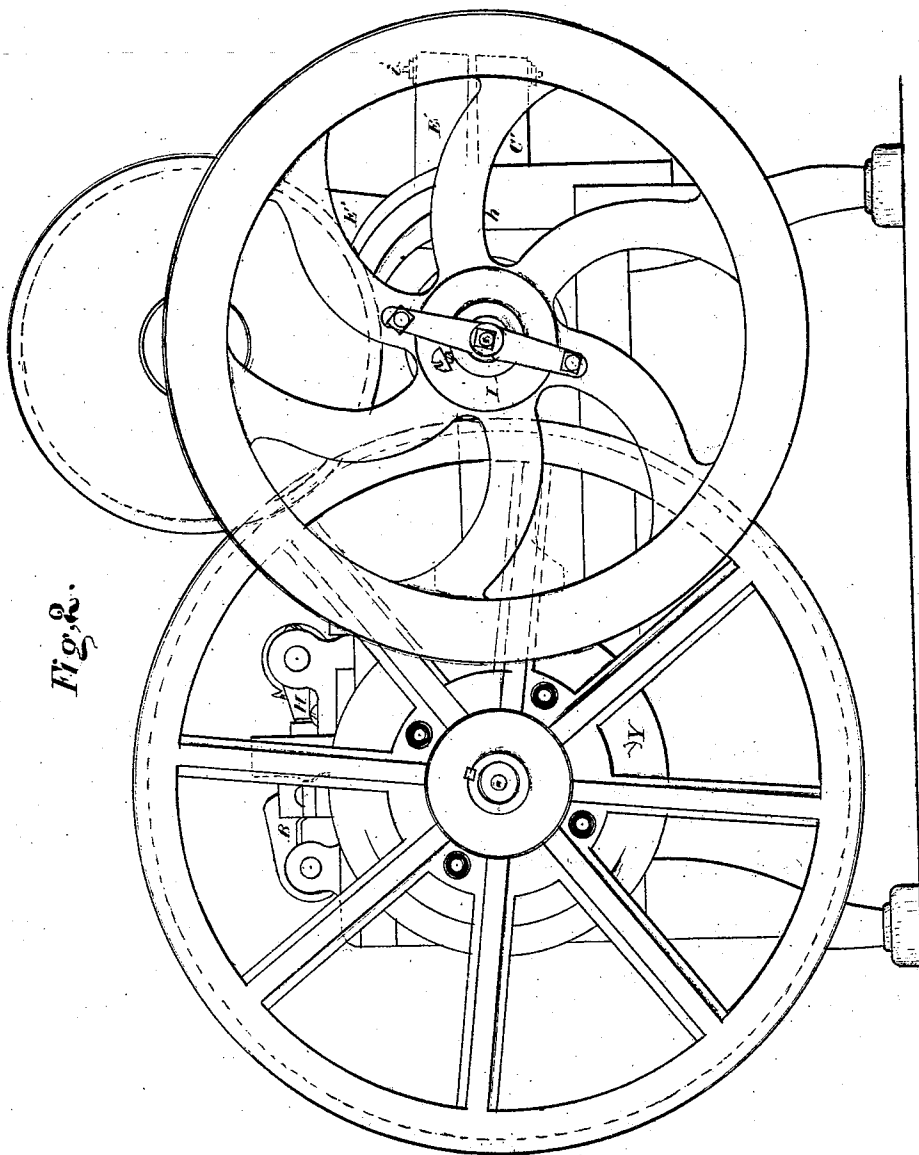

Fig. 2.

Inventor.
L. D. Roberts.
Per. Burridge & Co.

Witnesses.
J. G. Burridge
D. S. Humphrey.

L. D. ROBERTS.
Horseshoe-Machine.

No 101,513.

Patented Apr. 5. 1870.

Fig. 3.

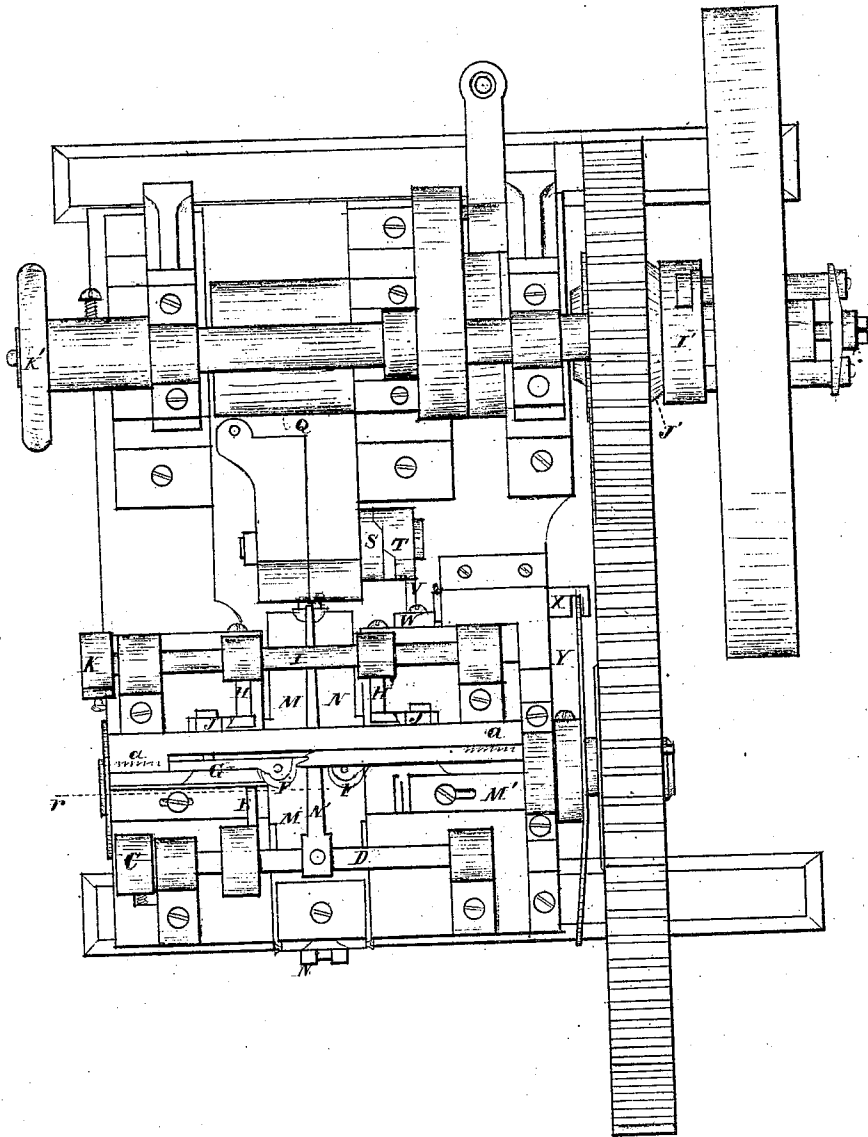

Inventor.
L. D. Roberts
Per Burridge & Co.

Witnesses.
J. H. Burridge
D. S. Humphrey

L. D. ROBERTS.
Horseshoe-Machine.

No. 101,513.

Patented Apr. 5, 1870.

Fig 4.

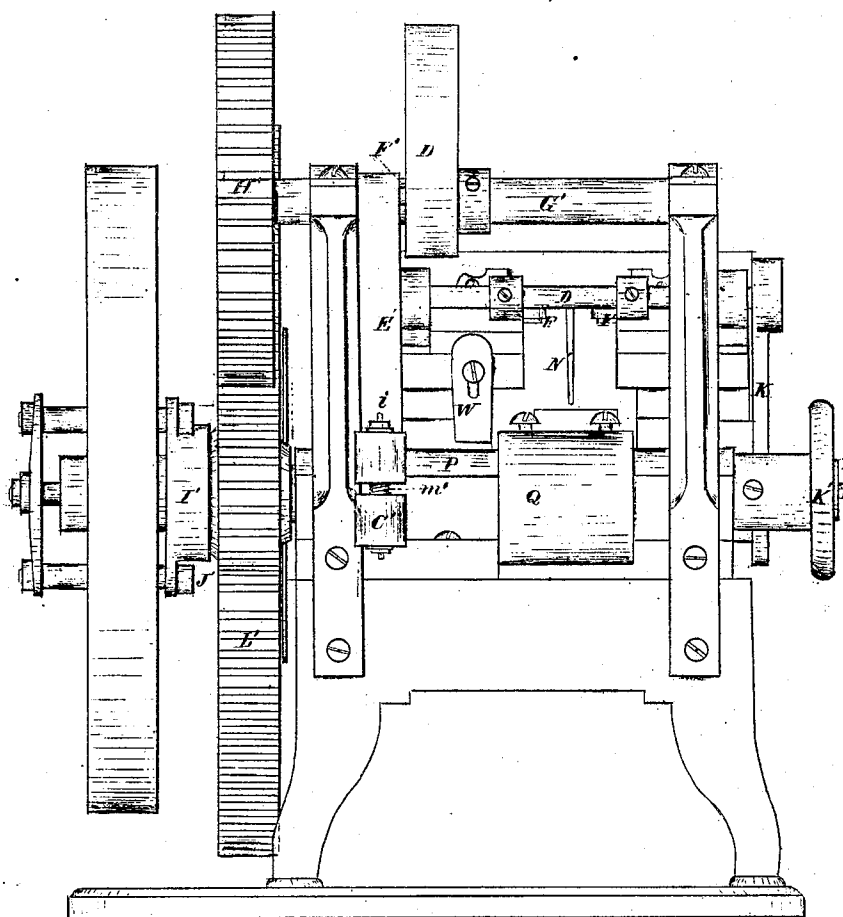

Inventor.
L. D. Roberts.
Per Burridge & Co.

Witnesses.
G. G. Burridge.
W. D. Humphrey.

L. D. ROBERTS.
Horseshoe-Machine.

No. 101,513.

Patented Apr. 5, 1870.

Fig. 5.

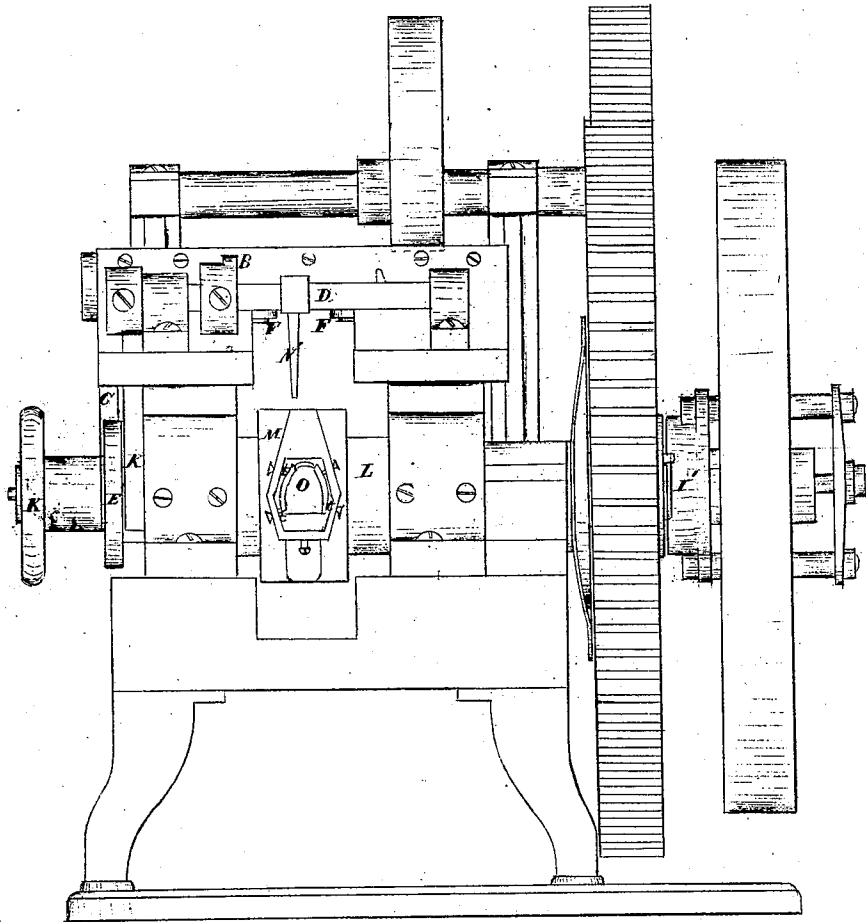

Inventor.
L. D. Roberts
Per. Burridge & Co.

Witnesses.
J. H. Burridge
D. S. Wumprey.

L. D. ROBERTS.
Horseshoe-Machine.

No. 101,513.

Patented Apr. 5, 1870.

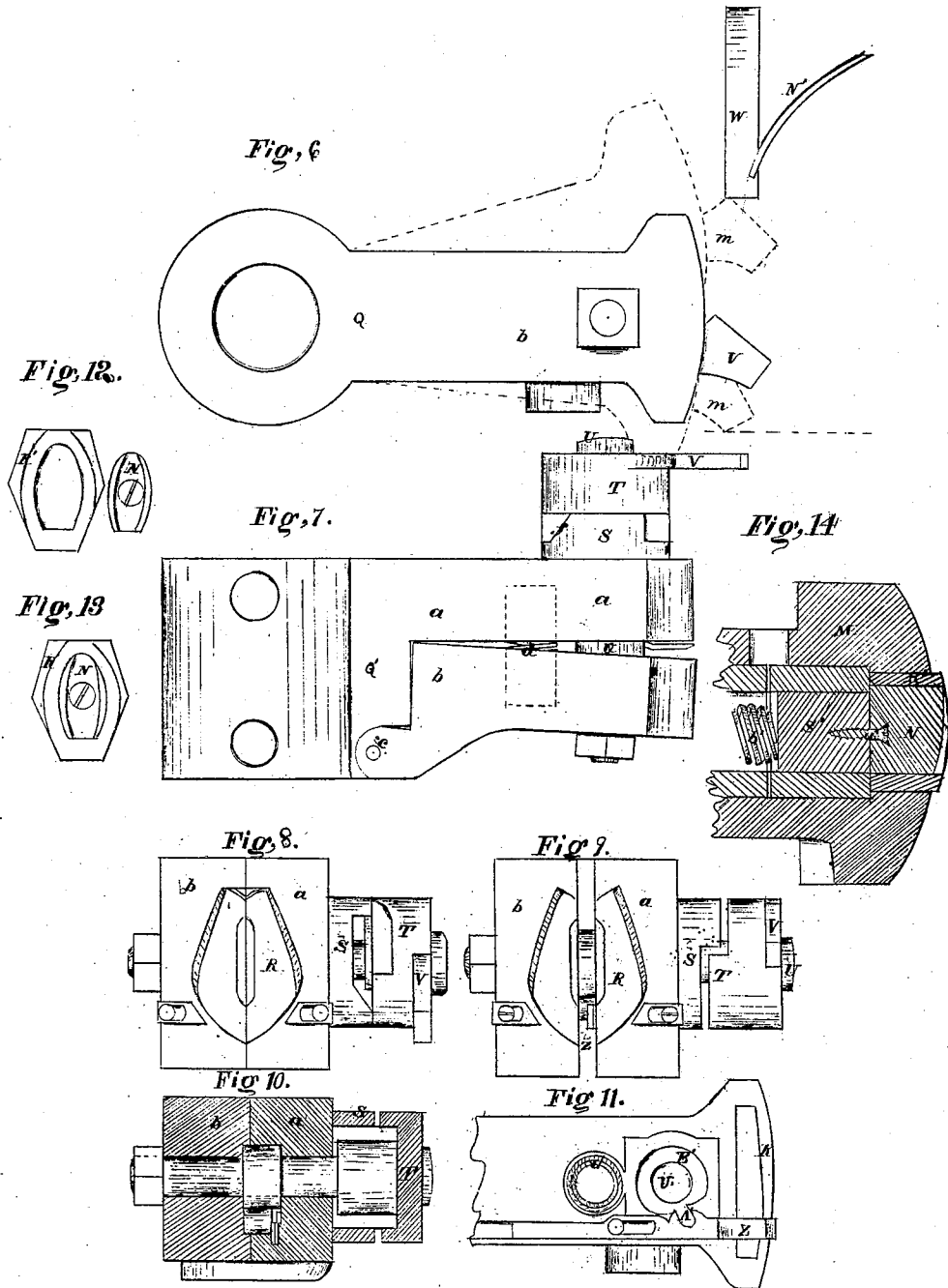

Inventor.
L. D. Roberts.
Per Burridge & Co.

Witnesses.
G. H. Burridge
S. D. Humphrey

United States Patent Office.

LAVAN D. ROBERTS, OF CLEVELAND, OHIO.

Letters Patent No. 101,513, dated April 5, 1870.

IMPROVED MACHINE FOR MAKING HORSESHOES.

The Schedule referred to in these Letters Patent and making part of the same.

To all whom it may concern:

Be it known that I, LAVAN D. ROBERTS, of Cleveland, in the county of Cuyahoga and State of Ohio, have invented a certain new and improved Horse-shoe Machine, being an improvement on a patent issued to me December 22, 1863, No. 41,922, for a horse-shoe machine; and I do hereby declare that the following is a full, clear and complete description of the same, reference being had to the accompanying drawings, making part of this specification, in which—

Figures 1 and 2 are side views of the machine, plates 1 and 2.

Figure 3 is a view of the top, plate 3.

Figure 4, a view of the rear end, plate 4.

Figure 5, a view of the front, plate 5.

Figures 6, 7, 8, 9, 10, 11, 12, 13, and 14, of plate 6, are detached sections, to which reference will be made.

Like letters of reference refer to like parts in the several views.

Objective.

This invention has for its object the manufacturing of horseshoes from a bar of iron, from which a piece is cut of the proper length for a shoe, is then bent over a former of the shape required, pressed, creased, partially punched, and discharged from the machine in one continuous automatic operation, as hereinafter more fully described.

Descriptive.

In fig. 1—

A represents a frame, upon and in which the several parts of the machine are arranged, and which consists of a knife, B, whereby a length for the shoe is cut from a bar.

Said knife has a vertical movement given to it by means of the arm C, depending from the end of the shaft D, fig. 3, to which the knife is secured.

Said arm is actuated by a cam, E, fig. 1, against the inner side of which the end of the arm engages, and thereby made to vibrate the shaft and knife at certain and equal times for the purpose of cutting the bars above-said.

Immediately in front of the knife referred to is a pair of rollers, F, fig. 4, a top view of which is shown in fig. 3.

Said rollers have a deep flange projecting from their upper side, and to them is given an inward lateral movement by means of a spring indicated by the dotted lines *a*, fig. 3, actuating the slides G, in which the rollers are pivoted.

Said sliders and rollers are actuated outwardly by a pair of arms, H, fig. 3, projecting from the shaft I,

and which impinge upon a pair of cam-lugs, J, attached to the slides, whereby they are forced outwardly and return back by the spring referred to.

The arms H obtain their vertical vibratory movement by means of the arm K, fig. 1, which in turn is operated by the cam E above described.

Below the above-described sections of the machine is secured, on the shaft L, figs. 5 and 3, a cross-arm, M.

In one end of the arm is secured a former or male die, N R', fig. 1, the shape and size of which conforms to that of the inside of a shoe.

A detached view of said die is shown in fig. 12, plate 6, in which it will be seen that it consists of two sections, N and R'.

Section R' is tightly fitted in the arm M, as shown in fig. 4; whereas, section N is closely but loosely fitted in section R', as shown in fig. 13.

At the bottom of the hole inclosing the die is a sliding core or bolt, S, fig. 14, to which the die N is secured by a screw, *a*.

At the inner end of the bolt is a spring, *b*', whereby the bolt and die are forced outwardly after being forced inwardly by contact with the female die.

The purpose of this movement of the die is to prevent unusual strain being exerted upon the dies in the event of a bar of iron of unusual thickness for the shoe being used.

The tension of the spring is such as to resist all necessary pressure for forming the shoe when a bar of proper thickness is used, but will yield to the increment of pressure caused by the use of a bar of more than the proper thickness.

In the opposite end of the arm referred to is secured a die, O, fig. 5, the purpose of which is to make the creases and nail-hole marks in the face of the shoe.

On the rear end of the machine is journaled a shaft, P, to which is secured an arm, Q, fig. 1, a detached section of which is shown in plate 6, fig. 7, in which it will be seen that it is constructed in two sections, *a* and *b*.

Section *b* is pivoted to section *a* at the point *c*, whereby the two sections are allowed to open and close like unto a pair of jaws.

In the end of said arm is sunk a female die, R, fig. 8, in shape and size to that of a shoe, and into which the partially-formed shoe is received, pressed, creased, and its shape completed, in the manner hereinafter shown.

The two sections of the arm just referred to are opened and closed as follows:

A spring, *d*, fig. 7, is secured between the jaws or sections, as shown in the drawings, and whereby the sections are opened, as shown in figs. 7 and 9.

The jaws are closed by a cam, S, attached to the side of the section *a*, operated by a corresponding cam, T, secured to a short shaft, U, fitted loosely in and projecting from the jaws, and which is operated by an arm, V, extending from the cam T, whereby an oscillating movement is given to it and the cam, by an adjustable dependent arm, W, fig. 4, with which the arm engages, at certain and equal times, thus:

The relative position of the two sections of the cam, as shown in fig. 7, are such as to bring their two inclined planes, faces, *f*, together, thereby allowing the jaw *b* to recede from the jaw *a*, as shown in figs. 7 and 9.

Now, as the movable section T of the cam may be turned by a downward direction given to its arm V by its contact with the end of the dependent arm W, the section will be forced away from section S, as shown in fig. 8, thereby drawing the jaws close, as shown in said figure.

To facilitate the closing of the jaws by the spring referred to, section T of the cam is given a reverse movement by its arm being made to come in timely contact with a slide, X, fig. 3, to which a reciprocating movement is given by a cam, Y, operating as will be seen, in a notch cut in the outer end of the slide, so that as the cam revolves the slide is given a lateral reciprocating movement, to the extent that the inner end of the slide is thrown so far that the descending arm of the cam strikes thereon, thereby reversing the action of the cam and allowing the jaws to open by the strength of the spring.

The shoe, when pressed into the die, as hereinafter shown, is forced therefrom by a slide, Z, fig. 11, operated backward and forward therein by a lug, A', projecting from the hub B' on the cam-shaft U into a notch in the slide, as shown in the drawing.

Said lug A' is operated by the arm V of the cam in its contact with the slide X at the instant that the arms are free for the opening of the die, in the manner as above described.

The arm Q is given a vibratory movement by an arm, C', fig. 1, connected to the shaft of said arm, and which is put in connection with a cam, D', fig. 4, by means of a supplementary right-angled arm, E', the vertical limb of which engages the cam by means of a pin or lug, F', projecting from the side of the limb into a groove cut around the margin of the cam or eccentric secured to the shaft G', to which motion is given by a gear-wheel, H'.

The supplementary arm E', referred to, is pivoted to the arm C' at the point *k*, and is also connected thereto by a bolt, *i*, passing through the outer extreme ends of the arms, and between which is interposed a spring, *m*, the purpose of which will presently be shown.

I, fig. 4, is a friction-clutch, consisting of a shell, in which is fitted a cone, secured to the end of a screw-shaft and operated by the hand-wheel K, whereby the cone is forced into the shell or therefrom, as may be required, for throwing the machine in and out of gear.

Operative.

Having thus described the construction and arrangement of the machine, the practical operation of the same is as follows, viz:

On motion being given to the several parts of the machine by the gearing H' and L', the end of a bar of iron, of the proper size, is now inserted under the knife or cutter B, as indicated by the dotted lines *r*, fig. 3. The length to be cut off is determined by the gauge M' at the instant that it is cut off.

The former or male die N, in the course of its revolutions, carries the piece thus cut off between the rollers F, directly under the flanges thereof, which

prevents any upward displacement of the iron while being bent around the former or die.

The rollers at this time are approximated by the timely movement of the spring *a*, actuating the slides of the rollers, thereby allowing them to roll along the edge of the iron in the line of its assuming curvature.

The iron thus bent around the die is retained thereon by the spring-finger N', under which it lies until it arrives at the female die R, which, by the exact adjustment of its movements by the cam or eccentric D' and arms above described, comes in line with and its face in direct relation to that of the male die, and receives the shoe, into which it is pressed by the male die, and rolls partially around therewith, but is (the female die) immediately returned back by the upward movement of the cam D', thereby bringing the female die and shoe again in proper position for receiving the creasing-die O, of which *t* are the creasers.

The said male die, in its rotation with the arm, is brought in contact with and bends the blank, as shown, into a U-shape, and being depressed or forced back as it comes in contact with the female die, leaves the blank therein for the action of the other male die, for creasing and pressing the shoe or blank left in the said female die.

The die R and shoe are again carried partially around with the creasing-die, as in the above instance, and receives from the die O the creases, and from the female die the completion of its form and joint.

This being done, the jaws of the die are opened, as shown in fig. 9, by the cams S T, operated as above described by the slide X, which at this moment is pushed forward toward the cams, and upon which the finger or arm thereof strikes, thereby disengaging them and allowing the jaws of the die to open by means of the spring.

As the jaws of the die open simultaneously therewith, the slide Z is pushed outwardly by the lug A', above described, which dislodges the shoe from the die, which falls to the ground, leaving the die free for the reception of another shoe.

It will be observed that the arm M, in the ends of which the forming and creasing-dies are placed, has a continuous rotating movement, whereas, the arm Q of the female die has an oscillating one.

The movements of the two arms are so timed that one-half the entire revolution of each of the dies of the arm M, is equal to one vibratory movement of the arm Q, the result of which is to bring the male and female dies in co-relation at a particular point in the revolution of the one and the vibratory movement of the other, whereby the pressing and creasing is done, and is continued so long as the contact of the two dies, male and female, continues with the shoe, which is during the downward movement of the arm Q for each die, O and N. Such movement is indicated by the dotted lines in fig. 6, which also indicate the movement of the cam, arm, or finger V.

It will be seen that the shoe on being received into the female die from the forming-die N is retained therein during two consecutive vibrations of the arm M, the first vibration, the partially-shaped shoe is received and completed, and during the second vibration of the arm it receives the creases from the die O, and is then discharged from the die in the manner above-said.

Should there be a variation in the thickness of the iron, or should it become displaced on entering, an unequal strain, as a consequence, will be exerted upon the machine while pressing, forming, and creasing the shoe.

To avoid this unequal strain and consequent danger of breaking some parts of the machine, the arm E',

fig. 1, which, as above said, is pivoted to the arm C' and between the outer limbs of which is interposed a spring, M, will relieve such unusual pressure by expending it more or less upon the strength of the spring instead of upon the dies, which would be the result were the connection between the shaft of the arm Q and the cam D' of a more rigid character.

By this means, bars of iron of more than the proper thickness for a shoe will exert less strain upon the dies and machine; hence, accidents are less liable to occur to the machine by breaking of any of its parts while in operation, in consequence of an unusually thick bar of iron being used.

It will also be observed that the male die N is not rigidly secured in the end of the arm, but loosely, so that there is allowed to it a movement in the direction of the arm, and therefore can be forced back into the arm, even with the face of the die, and which it will be on its contact with the female die, but again forced out by a spring situated at its inner end.

The purpose of this movement of the die is to allow it to free itself from the shoe after pressing, as above said, the horizontal limbs of the arms C' and E', are connected to each other by a bolt.

The purpose of the bolt is also for giving more or less tension to the spring *m* interposed between the arms, and thereby graduate the pressure of the dies according to the thickness of the iron used for the shoe.

Claims.

What I claim as my improvement, and desire to secure by Letters Patent, is—

1. The arm C', spring *m*, in combination with the arm E, wrist-pin F, cam D', and operating-shaft, conjointly in the manner and for the purpose substantially as set forth.

2. In combination with the vibrating jaws *b a*, shaft U, the slide Z, and hub B', provided with the lug A', or its equivalents, substantially as and for the purpose set forth.

3. The spring-finger N', in combination with the forming and facing-die N R', and the cross-arm M, for the purpose and in the manner substantially as set forth.

4. The forming and facing-die N R', in combination with the spring *b'*, and cross-arm M, substantially as and for the purpose set forth.

5. The combination with the cams S T, vibrating jaws of the arm Q, and adjustable stop W, the slide X, and cam Y, substantially as described and for the purpose set forth.

L. D. ROBERTS.

Witnesses:

J. H. BURRIDGE,
J. HOLMES.