

No. 748,362.

PATENTED DEC. 29, 1903.

J. A. GIBBONS.  
LUBRICATING DEVICE.  
APPLICATION FILED APR. 25, 1903.

NO MODEL.

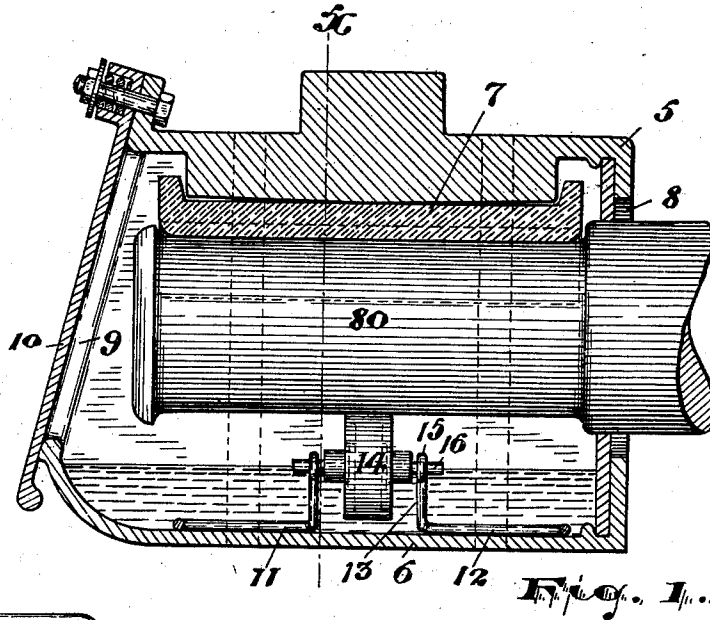

Fig. 1.

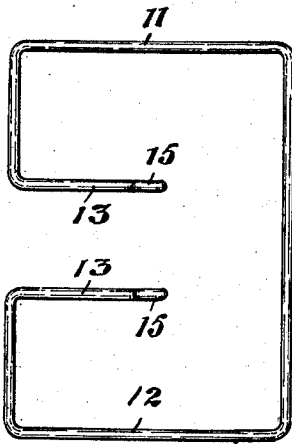

Fig. 3.

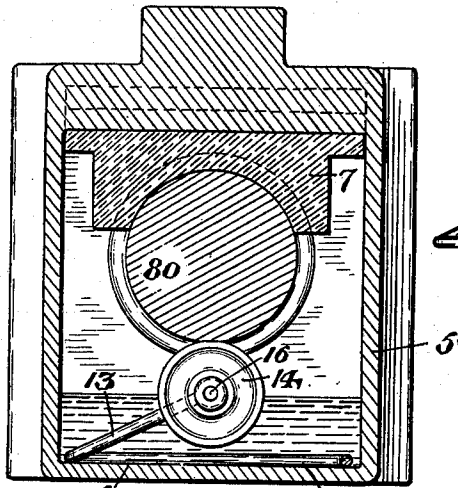

Fig. 2.

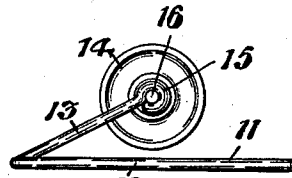

Fig. 4.

WITNESSES:  
*Ralph Lancaster.*  
*Russell M. Everett.*

INVENTOR:  
*John A. Gibbons,*  
BY  
*Charles H. Pell*  
ATTORNEYS

# UNITED STATES PATENT OFFICE.

JOHN A. GIBBONS, OF ELIZABETH, NEW JERSEY.

## LUBRICATING DEVICE.

SPECIFICATION forming part of Letters Patent No. 748,362, dated December 29, 1903.

Application filed April 25, 1903. Serial No. 154,223. (No model.)

*To all whom it may concern:*

Be it known that I, JOHN A. GIBBONS, a citizen of the United States, residing at Elizabeth, in the county of Union and State of New Jersey, have invented and produced a new and useful Improvement in Lubricating Devices; and I do hereby declare the following to be a full, clear, and exact description of the invention, such as will enable others skilled in the art to which it appertains to make and use the same, reference being had to the accompanying drawings, and to numerals of reference marked thereon, which form a part of this specification.

The objects of this invention are to facilitate the work of lubricating a car-axle, to secure a more perfect and continuous lubrication, to enable the lubricator to be easily applied to the axle without interference with the normal relations of the axle and its bearings, to enable the feed-roller to be easily removed from the spring for the purposes of renewal or repair, and to secure other advantages and results, some of which may be referred to hereinafter in connection with the description of the working parts.

The invention consists in the improved lubricating device for car-axles and in the arrangements and combinations of parts of the same, all substantially as will be hereinafter set forth, and finally embraced in the claim.

Referring to the accompanying drawings, in which like numerals of reference indicate corresponding parts in each of the several figures, Figure 1 is a vertical sectional view of a journal-bearing box for cars. Fig. 2 is a section of the same, taken at line *x*. Fig. 3 is a detail plan of the spring for supporting the feed-roller, and Fig. 4 is a side elevation showing the feed-roller arranged on its bearings in said spring.

In said drawings, 5 indicates the journal-box, having at its bottom a receptacle for a liquid lubricant, the floor 6 of said receptacle being flat to provide a suitable surface on which the spring may be firmly seated. The top of said box provides a bearing for the axle-plate 7 on the inside and a seat on the outside, on which the body of the car rests directly or indirectly. At one side of said box the same is open, as at 8, to permit the axle 80 to pass through, and at the opposite side

is an opening 9, through which the liquid lubricant, &c., may be inserted, the last said opening being closed by a cover 10 of any suitable construction. On said flooring is seated the supporting-spring 11. This is shown in plan in Fig. 3 and comprises an oblong right-angular base-frame 12, of resilient wire, the ends of which at one side of the frame extend toward one another; but before meeting at the center said ends are bent inward and upward from the plane of the said base-frame, as shown in Fig. 4, forming parallel arms 13 13, which lie a little apart from one another to receive the feed-roller 14 therebetween. The extremities of the arms are bent or turned to form eyes 15, in which the shaft or pivotal pins 16 of the said feed-roller are loosely arranged. The arms 13 of the resilient wire tend to normally hold the roller so that it presses with considerable force against the axle, and thus said roller is turned frictionally on its axial pins or shaft 16 to raise the adhering lubricant. Said feed-roller 14 is of a size smaller than the diameter of the axle 80, and thus when pressed up against said axle it rotates with an augmented speed, and the liquid lubricant, in which the lower part of the roller lies, is thrown or carried copiously upward by said roller to the axle and thence to the joint between the axle and bearing-plate.

The resilient wire permits the arms 13 13 to be pressed laterally apart, so that the roller may be freely detached. It also permits the frame to be easily bent temporarily, and so removed from the box through the opening 9. The peculiar bending of the ends of the wire at the open side permit the roller to be removed without at the same time removing the frame with peculiar ease, and yet the roller is held normally within the eyes with great security.

Having thus described the invention, what I claim as new is—

The improved lubricating device for car-axles, comprising a frame consisting of a single piece of resilient wire bent into oblong form, the free ends of the said wire, at one side of the frame, extending toward one another and, near the center of said side, being bent inward from said side of said frame, and being separate from one another at their in-

ward bends to form an open space between  
at said one side of said frame, the inward ex-  
tensions or arms of said ends being integral  
with the body portion of the frame and par-  
5 allel with one another and at their inner ex-  
tremities being turned to form eyes to receive  
the pins of the oil-feeding roller and hold the  
same in place, and said feeding-roller adapted  
to be arranged between said inwardly-extend-  
10 ing arms, the pivotal pins thereof lying in

said eyes and being removable therefrom  
when the arms are sprung outwardly and away  
from said roller, substantially as set forth.

In testimony that I claim the foregoing I  
have hereunto set my hand this 22d day of 15  
April, 1903.

JOHN A. GIBBONS.

Witnesses:

CHARLES H. PELL,  
C. B. PITNEY.