

[54] MATERIAL STRIPPING APPARATUS AND BLADE

[76] Inventor: Wesley J. Oliverius, 1332 Fisherman Road, Norfolk, Va. 23503

[22] Filed: May 28, 1971

[21] Appl. No.: 147,766

[52] U.S. Cl.299/37, 173/24

[51] Int. Cl.E04d 15/00

[58] Field of Search299/37; 15/93

[56] References Cited

UNITED STATES PATENTS

3,272,559	9/1966	Haynes.....	299/37
2,874,946	2/1959	Singleterry et al.	299/37
2,777,680	1/1957	Robb.....	299/37
3,475,841	11/1969	Delfino et al.	299/37 X

Primary Examiner—Ernest R. Purser
Attorney—Beveridge and De Grandi

[57] ABSTRACT

A material stripping machine including a movable carriage on which is located a motor for providing reciprocating motion to a blade member having a cutting edge for stripping material. Mounted on the carriage behind the blade member is a diverter means for diverting stripped material to either side of the carriage so that it does not block the forward movement of the machine. The cutting edge of the blade member comprises a series of beveled teeth, and the body of the blade member has projecting upwardly therefrom at least one subsidiary cutting member having a cutting edge facing the cutting edge of the blade member for cutting through material stripped by the blade.

11 Claims, 7 Drawing Figures

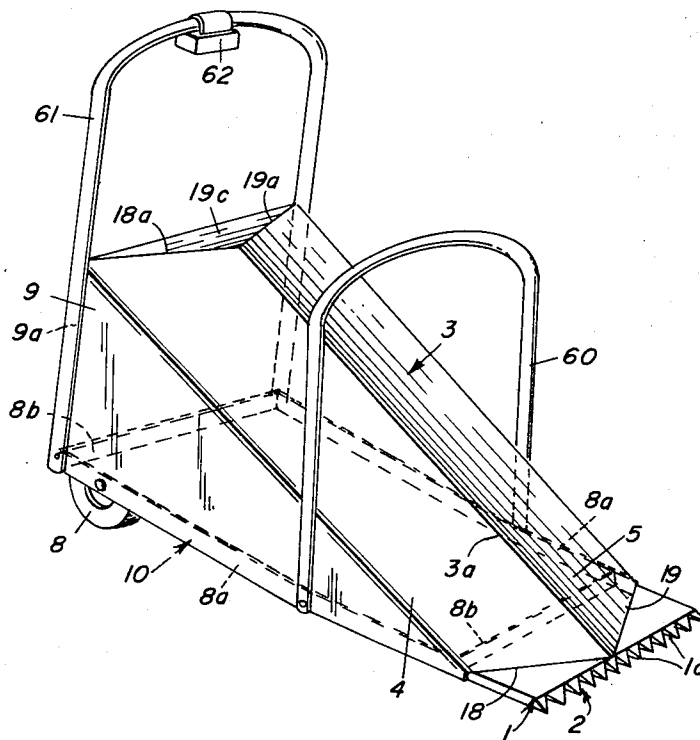

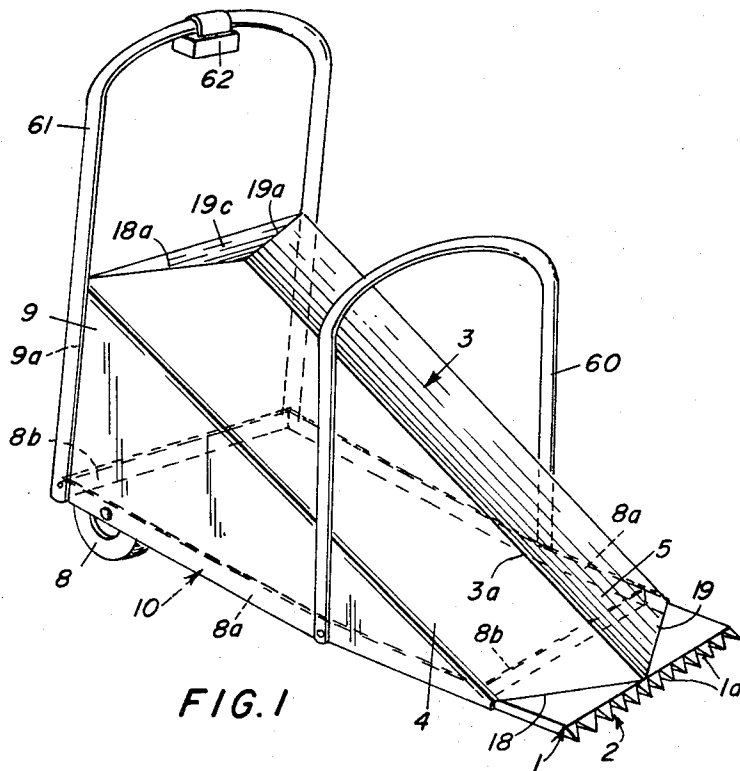

FIG. 1

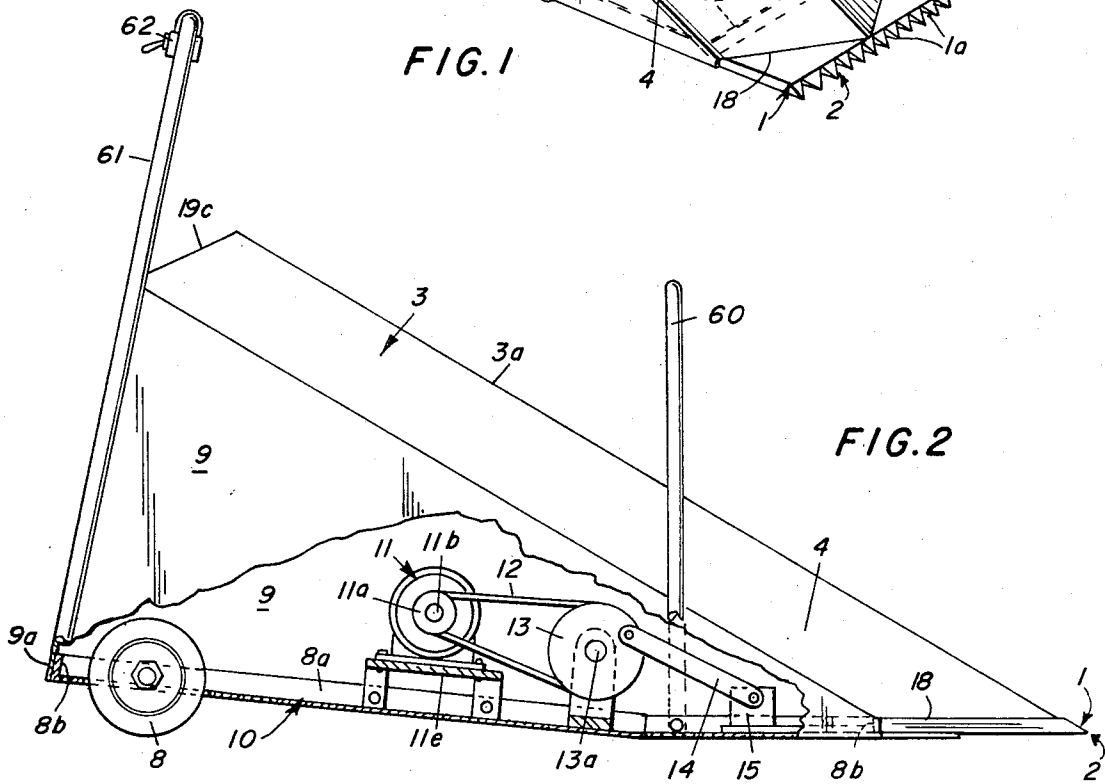
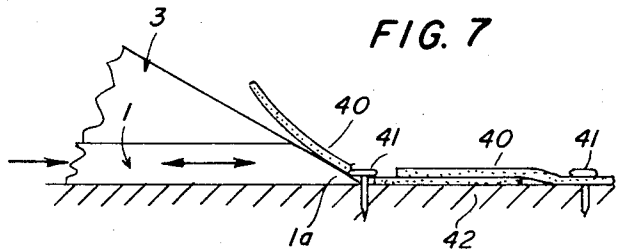
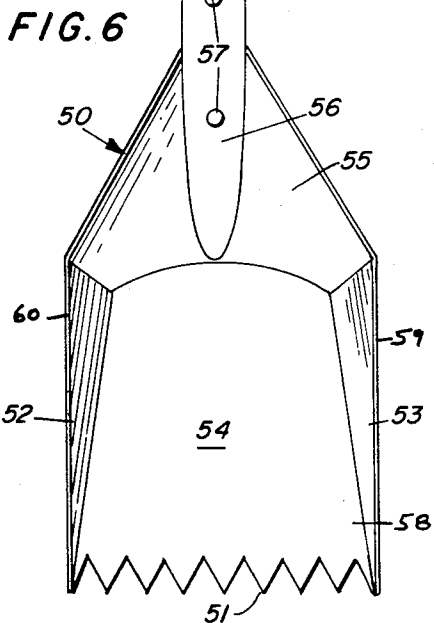
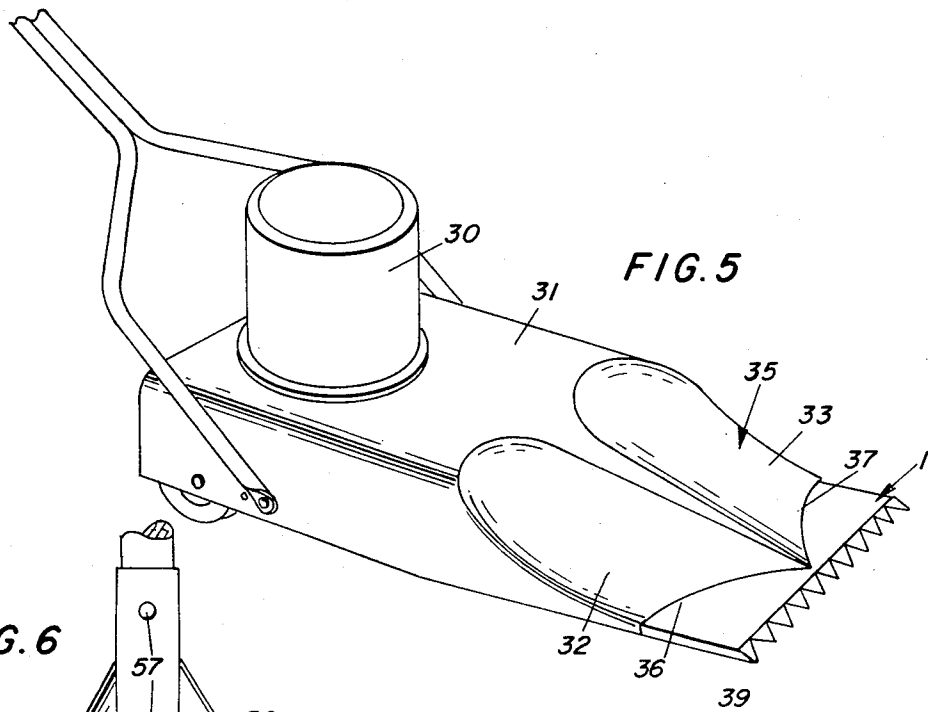
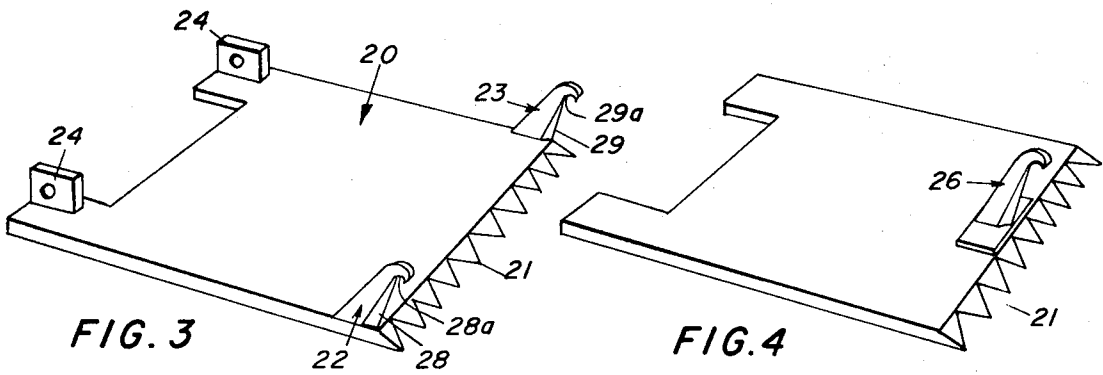

FIG. 2

INVENTOR
W. J. OLIVERIUS

BY *Beveridge and DeGrandi*
ATTORNEYS



INVENTOR
W. J. OLIVERIUS

BY *Beveridge and de Grandi*
ATTORNEYS

MATERIAL STRIPPING APPARATUS AND BLADE**BACKGROUND OF INVENTION AND OBJECTS**

This invention relates to a new and improved stripping machine which is used to strip sections of material from a surface to which they are bonded and/or nailed. The invention further relates to a new and improved blade member which may be used with a material stripping machine and to a manual stripping tool which incorporates the new and improved blade member. Although the material stripping machine and manual stripping tool of the present invention are highly suited for the purpose of removing shingles from a roof surface, they may also be used for stripping sections of any type of covering material.

One disadvantage of the prior art stripping machines has been their inability to move stripped material out of the way so as to provide a clear path for the forward movement of the stripping machine. As a result the stripped material would accumulate immediately in front of the stripping machine and consequently impede progress of the stripping operation. The present invention solves this problem by providing a diverter means immediately behind the stripping blade for diverting stripped material to one side of the machine or the other. Thus with the use of the present invention, stripped material will not accumulate in front of the machine and block the forward progress thereof.

Another problem associated with stripping machines of the prior art has been their inability to effectively remove shingles or sections of other material which are wider than the width of the stripping blade. The present invention obviates this problem by providing a stripping blade member which has projecting upwardly therefrom, at least one subsidiary cutting member for cutting through the portion of the shingle or section of other material which is operated on by the stripping blade. Thus the blade of the present invention is effective to strip shingles or sections of material even though the shingles or sections are much wider than the width of the stripping blade.

Another deficiency of prior stripping machines has been their inability to get under the material to be stripped and also to sever and remove nails or other similar fasteners securing the material to the underlying surface. This problem is also overcome by the present invention.

It is therefore an object of the present invention to provide improved material stripping apparatus which incorporates a diverter means located behind the stripping blade to divert stripped material to one side or the other.

It is a further object of the invention to provide a material stripping apparatus incorporating a novel stripping blade which has thereon at least one subsidiary cutting member for cutting through material stripped by the blade member.

A still further object of the invention is to provide a new and improved stripping blade which in operation, will pass under the material to be stripped and sever and remove any nails or other fasteners securing the material to thus provide highly effective stripping.

Another object of the present invention is to provide such material stripping apparatus that may be easily and safely handled by a single operator even when employed on a sloped roof of a building.

Another object of the invention is to provide a manual stripping tool which incorporates the new and improved stripping blade of the present invention and which is effective to remove any fasteners securing the material to be stripped and to cut through and sever the material stripped.

One embodiment of the present invention achieving the above object includes a movable carriage in which a motor is mounted for reciprocating a stripping blade situated in the front end of the carriage. The cutting edge of the stripping blade has a plurality of beveled teeth extending thereacross which teeth have the ability to dig under the material to be stripped and to sever and remove nails holding down the material to be stripped. It is preferred that the stripping blade have at least one subsidiary cutting member projecting upwardly therefrom for cutting through material stripped by the blade. Located behind the stripping blade is a diverter structure for diverting stripped material to either side of the apparatus. The diverter includes a pair of angularly disposed, inclined surfaces and is located rearwardly of the stripping blade sloping downwardly to opposite sides of the apparatus. These surfaces may be flat or curved and may also form a hood for the carriage enclosing the motor.

Other objects and advantages of the present invention will become apparent from the following detailed description in conjunction with the attached drawings in which:

FIG. 1 is a perspective view of a machine embodying the present invention;

FIG. 2 is a side view of the machine shown in FIG. 1 with a side wall of its housing partially removed to show components therein;

FIGS. 3 and 4 are perspective views showing alternate embodiments of the improved blade of the present invention;

FIG. 5 is a perspective view of another embodiment of the present invention;

FIG. 6 is a view of a manual stripping tool according to the invention;

FIG. 7 is a side view showing the blade member in the process of stripping a section of material from a surface.

DETAILED DESCRIPTION

Referring to the drawings in detail and initially FIGS. 1 and 2, there is shown for illustrative purposes only, one embodiment of the present invention including a carriage 10 supported at its rear end by wheels 8 which are mounted in any suitable frame which may comprise opposite side members 8a interconnected by opposite end members 8b to form a rigid rectangular structure. The frame members may be made from any suitable material such as steel. Wheels 8 may be mounted directly to the frame members themselves as in the shown embodiment or may be mounted on a cross axle (not shown) which in turn is mounted in the frame members 8a.

Located on carriage 10 is a motor generally designated 11 which includes a drive pulley 11a operatively connected to a fly wheel 13 to drive the same in rotation by means of a pulley belt 12. Pulley belt 12 in this specific embodiment is mounted to a pulley (not shown) which in turn is secured to a shaft 13a to which

the fly wheel 13 is rigidly fixed. In this specific embodiment, another pulley 11a and fly wheel 13 combination is provided on the other side of the carriage; the pulleys 11a being fixed to a shaft 11b driven by motor 11. Motor 11 may be supported on frame 8a by a cross strut 11e having its opposite ends fixed to frame members 8a. Fly wheels 13 each have a linkage member 14 eccentrically mounted thereto which linkage member 14 is pivotally connected at its other end with respect to blade member 1 by means of an attachment lug 15 for providing reciprocating motion to the blade member. The carriage and motor mechanism is enclosed by a housing including opposite vertical side walls 9, an end wall 9a, and a diverter means 3 located between the side walls and projecting forwardly and downwardly from end wall 9a. A conventional U-shaped handle 61 with an on-off switch 62 for switching the motor on is located at the rear of the carriage and another U-shaped handle 60 is located at a point in front of the mid-point of the carriage.

In the front of the machine, blade member 1 is slidably mounted on frame 10 for reciprocation in a plane parallel to the frame 10. Blade member 1 has across its front end, a cutting edge 2 comprised of a plurality of beveled teeth 1a. Beveled teeth 1a are used in the manner illustrated in FIG. 7 to engage under and strip material such as shingles 40 from an underlying surface 42. The bevel of the cutting edge teeth 1a allows them to dig under material to remove it from the surface to which it is bonded or otherwise secured. Additionally, the spacing of the teeth 1a is arranged so that nails or tacks such as 41 shown in FIG. 7, which secure material 40 to surface 42 may be engaged and severed in the space between teeth 1a and pried out of surface 42 when the blade member moves forwardly during operation.

Diverter means 3 includes surface 4 and 5 which act to divert stripped material to either side of the machine out of the path of the machine during operation. Surfaces 4 and 5 are flat, and at their forward ends, have bottom edges 18 and 19 respectively which meet each other substantially at the center of the cutting edge 2 of blade 1. Additionally, surfaces 4 and 5 incline upwardly in the direction away from the blade towards the rear of the machine while also sloping laterally downwardly to opposite sides of the machine from a common line 3a which joins the juncture of edges 18 and 19 at the plane of blade member 1. In this specific embodiment shown, surfaces 4 and 5 terminate at their upper ends at edges 18a and 19a such that surfaces 4 and 5 are connected to rear end wall 9a by a triangular section 19c as shown in FIG. 1.

The unique geometrical arrangement of surfaces 4 and 5 provides extremely effective diversion of shingles or other sections of material stripped by the machine. In this latter regard, material stripped by blade 1a begins to move upwardly along surfaces 4 and 5 and subsequently laterally and downwardly along surfaces 4 and 5 to opposite sides of the machine. It will be seen that the hood and diverter structure also acts as a guide member for the blade 1a to ensure that it remains in a plane generally parallel to the frame of the carriage. During use, the machine is pushed forwardly by the operator via handle 61 and the machine is manipulated upwardly or downwardly by pivoting it about wheels 8;

it being understood that no wheels are provided at the front end of the carriage. An additional handle 60 is provided at the front of the machine and in certain circumstances it may be more expedient to manipulate the machine by the use of this handle. Additionally, the second handle may be used by a second man in situations where it is desirable to have two men manipulate the machine.

The embodiment of the machine shown in FIG. 5 may be considered to be a streamline version of the machine shown in FIGS. 1 and 2. In this embodiment, the motor is located within motor housing 30 situated on top of housing 31 which is considerably lower in height than the housing used in the embodiment of FIGS. 1 and 2. Diverter means 35 is comprised of surfaces 32 and 33 which are concave surfaces as shown in FIG. 5 having curved bottom surfaces which extend rearwardly of the cutting blade. The diverting action of diverter means 35 is very similar to that of the diverter means 3 in the embodiment of FIGS. 1 and 2. The drive and reciprocating mechanism in the present embodiment may be similar to that in the embodiment of FIGS. 1 and 2.

FIGS. 3 and 4 illustrate two embodiments of an improved blade member further in accordance with the present invention. Blade member 20 has a transverse cutting edge 21 in its forward end consisting of a plurality of beveled teeth which are used to strip material in the manner shown in FIG. 7 as explained above. In the FIG. 3 embodiment, the blade member has a pair of subsidiary cutting members 22 and 23 projecting upwardly therefrom on the opposite side edges of the blade member just rearwardly of cutting edge 21 as shown in FIG. 3. Subsidiary cutting members 22 and 23 may be fixed in any suitable manner such as by welding to the blade member. Subsidiary cutting members 22 and 23 have forwardly facing cutting edges including vertically extending edges 28 and 29 terminating in hooked cutting edges 28a and 29a at the top thereof. Additionally, blade member 20 has a pair of attachment means 24 at the rear end thereof for attachment to a drive member. In the embodiment of FIG. 4 which is illustrated without attachment means 24, a single subsidiary cutting member 26 is secured to the central portion of the blade in alignment with the mid-point of the cutting edge 21 of the blade. Cutting member 26 is the same as 22 and 23.

The function of the subsidiary cutting members 22, 23 and 26, is to cut through material such as roofing shingle or tar paper which has been stripped by cutting edge 21. This is extremely useful in cases where the shingle or material to be stripped is several times wider than the cutting edge 21, in which case without the subsidiary cutting members, it would be difficult if not impossible to remove sections of the shingle from the surface in one pass of the machine. It will further be seen that the subsidiary cutting members will cut the stripped material into discrete pieces which not only allows the cutting operation to proceed but further facilitates guidance of the removed pieces to either side of the machine by the diverter mechanism and subsequent handling and disposal of the removed pieces.

FIG. 6 shows a manual stripping tool 50 which resembles a shovel. Handle member 56 (not shown in its entirety) is secured to curved connecting member

55 by attachment means 57. Curved connecting member 55 is attached at its lower end to plane surface 54 which has a cutting edge comprised of a plurality of beveled teeth at its front end. Extending rearwardly from cutting edge 51 at each end thereof are subsidiary cutting members 52 and 53. These members have knife-edge cutting edges 60 and 59 on their topmost surfaces and are tapered upwardly as they extend rearwardly so that the height of the cutting edge is greater near the rear of plane surface 54 than at the front of it. Additionally, members 52 and 53 are flanged outwardly so that they join plane surface 54 at an angle between 90° and 180°. Members 52 and 53 may be integrally formed with plane surface 54. Additionally, members 52 and 53 join curved connecting member 55 at their rear ends to form a unitary structure.

Manual stripping tool 50 is manipulated by handle 56 to strip shingles or other material which may be secured by nails or other fasteners. It is moved in a forward motion under the material to be stripped so that the nails or fasteners are engaged and removed by teeth 51 as shown in FIG. 7. Additionally, subsidiary cutting members 52 and 53 cut through material which is stripped by cutting edge 51. In this way a piece of material such as a shingle which is several times as wide as cutting edge 51 can be effectively stripped.

While the improved blade of the present invention has been illustrated in use with the two stripping machines disclosed and with the manual stripping tool disclosed it is not intended to be limited to such use but rather can be used with any material stripping machine or manual stripping tool.

What is claimed is:

1. Material stripping apparatus comprising in combination; a movable carriage, a blade member mounted at the front end of said carriage, said blade member having a cutting edge for stripping material, and a diverter means mounted on said carriage behind said blade member for diverting stripped material to either side of said carriage, said diverter means comprising a body extending upwardly from the base in the rearward direction of the carriage and having a pair of angularly disposed inclined surfaces sloping downwardly to opposite sides of said carriage respectively.

2. Apparatus defined in claim 1 wherein said surfaces meet at a common line located behind the center of said blade member in general alignment therewith.

3. Apparatus defined in claim 2 wherein said surfaces have a bottom edge and wherein said common line therebetween runs into said bottom edge.

4. Apparatus defined in claim 3 wherein each of said surfaces is a plane surface.

5. Apparatus defined in claim 3 wherein each of said surfaces is a curved surface.

6. Apparatus defined in claim 2 further including a motor means mounted on said carriage and operatively connected to said blade member for reciprocating the same, and wherein said diverter means including said surfaces thereof constitutes a hood for said carriage enclosing said motor means.

7. Apparatus defined in claim 1 further including motor means for reciprocating said blade member, said blade member being positioned with respect to said carriage so that when said carriage rests on a horizontal plane, the blade member lies in a horizontal plane to be reciprocated in said horizontal plane.

8. The machine of claim 7 wherein said blade member has at least one subsidiary cutting member projecting upwardly therefrom to cut through material stripped by the cutting edge of said blade member.

9. The machine of claim 8 wherein the cutting edge of said blade member comprises a plurality of beveled teeth.

10. The machine of claim 9 wherein said motor means is located on said carriage and said diverter also constitutes a hood for said carriage enclosing said motor means.

11. Material stripping apparatus comprising in combination; a movable carriage, a blade member mounted at the front end of said carriage, said blade member having a cutting edge for stripping material, said blade member further including at least one subsidiary cutting member projecting upwardly therefrom to cut through material stripped by the cutting edge of said blade member, and a diverter means mounted on said carriage behind said blade member for diverting stripped material to either side of said carriage, and wherein the cutting edge of said blade comprises a plurality of beveled teeth extending across and constituting said cutting edge of the blade member, and wherein each of the teeth have a generally triangular shape including opposite sides converging to pointed extremities.

* * * * *

50

55

60

65