

A. W. NICHOLLS.
 GAS TUBE TIP.
 APPLICATION FILED JAN. 24, 1910.

1,006,588.

Patented Oct. 24, 1911.

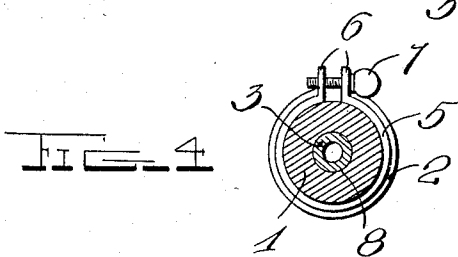
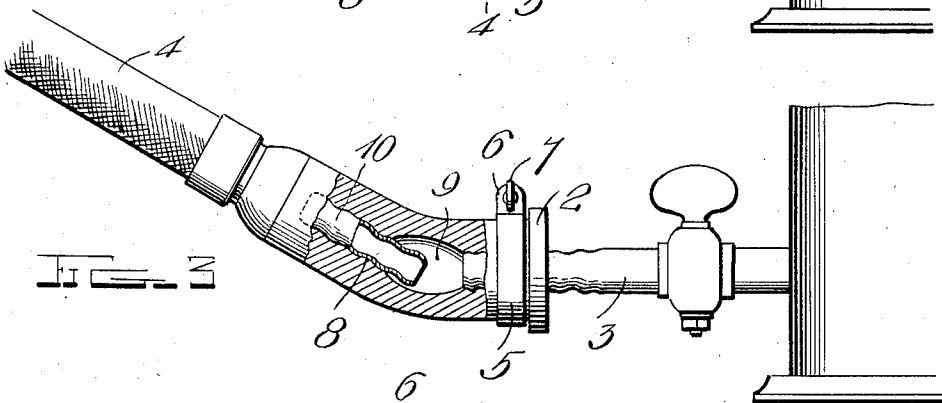
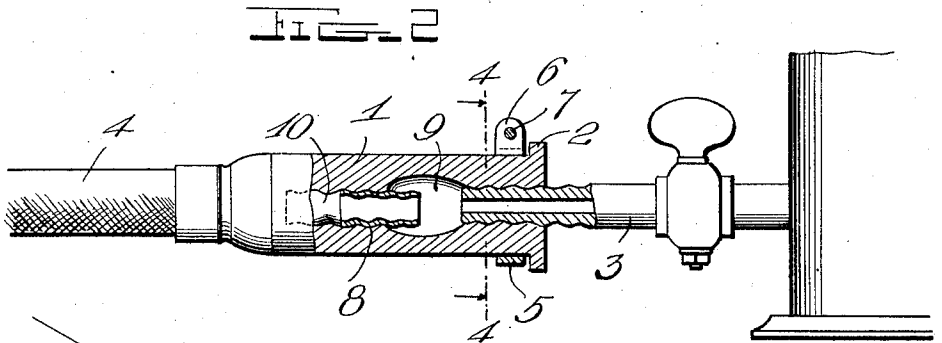
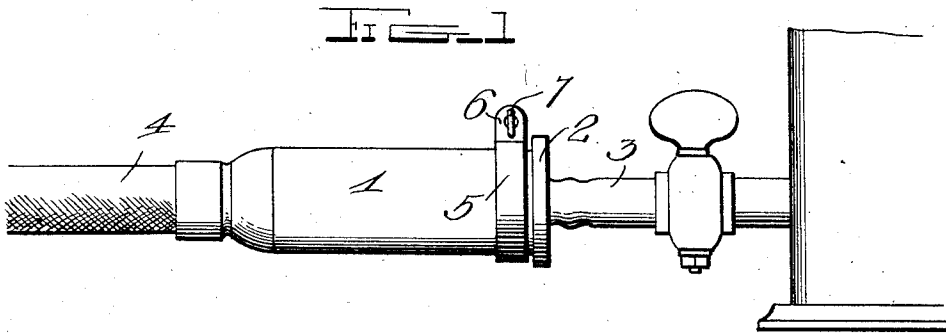

Witnesses

J. Reunke
C. H. Christman

Inventor

A. W. Nicholls

by *A. B. Wilson & Co.*
 Attorneys

UNITED STATES PATENT OFFICE.

ALBERT W. NICHOLLS, OF EAST NORWALK, CONNECTICUT.

GAS-TUBE TIP.

1,006,588.

Specification of Letters Patent. Patented Oct. 24, 1911.

Application filed January 24, 1910. Serial No. 539,783.

To all whom it may concern.

Be it known that I, ALBERT W. NICHOLLS, a citizen of the United States, residing at East Norwalk, in the county of Fairfield and State of Connecticut, have invented certain new and useful Improvements in Gas-Tube Tips; and I do declare the following to be a full, clear, and exact description of the invention, such as will enable others skilled in the art to which it appertains to make and use the same.

This invention relates to an improved rubber gas tip for connecting a hose to a gas stove.

One object of the invention is to provide a simply constructed and efficient gas tip of this class for use on gas stove tubes provided with means for securely connecting it to a stove nipple.

Another object is to provide a tip of this class with reinforcing and strengthening means at a point where the most strain is exerted.

With the foregoing and other objects in view, the invention consists of certain novel features of construction, combination and arrangement of parts as will be more fully described and particularly pointed out in the appended claim.

In the accompanying drawings, Figure 1 is a side elevation of this improved tip applied; Fig. 2 is a longitudinal section thereof; Fig. 3 is a similar view showing the tube sleeve arranged at an angle within the tip; Fig. 4 is a transverse section taken on the line 4-4 of Fig. 2.

In the embodiment illustrated, the rubber tip 1 is provided with a longitudinal bore throughout its length and at its outer end on its exterior surface with an annular reinforcing flange or rib 2, to adapt it to securely fit on the stove nipple 3 and prevent its slipping off when the gas supply tube 4 with which it is connected is bent either up or down. Arranged on this tip 1 adjacent the flange 2 is a split clamping ring or collar 5, the ends of which are provided with laterally extending apertured ears as 6. A winged tightening screw or bolt 7 is oper-

able in said ears for drawing them together to cause the clamp to firmly engage the rubber tip 1 and reliably lock it to the stove nipple 3. The longitudinal bore 8 of this tip 1 is provided intermediately of its ends with an enlarged recess 9 for the reception of the outer end of a metal tube or nipple 10 which is carried by the hose to be connected being secured thereto by any suitable means. This recess 9 permits the free end of said tube 10 to move freely to provide for the lateral movement of the hose 4 without danger of forcing the tip 1 off the stove nipple or tearing it at the point where the end of tube 10 is arranged which is the point where the greatest strain is exerted when the hose is moved laterally and the elongated reduced bores at the opposite ends of the recess form extended grip members for reliable engagement with the metal nipples 3 and 10 to be connected.

From the foregoing description taken in connection with the accompanying drawings, the construction and operation of the invention will be readily understood without requiring a more extended explanation.

Various changes in the form, proportion and the minor details of construction may be resorted to without departing from the principle or sacrificing any of the advantages of this invention as defined in the appended claim.

Having thus described my invention, what I claim is:—

A rubber connecting tip comprising a member having an enlarged recess formed in its interior intermediately of its ends, said ends forming extended gripping members, and a metal nipple inserted in the bore of one of said members and having one end projecting into said recess to provide for the bending of the tip without danger of injuring it.

In testimony whereof I have hereunto set my hand in presence of two subscribing witnesses.

ALBERT W. NICHOLLS.

Witnesses:

HAZEL B. POTTER,
ETHEL L. McLEAN.