

(12) PATENT
(19) AUSTRALIAN PATENT OFFICE

(11) Application No. AU 199914788 B2
(10) Patent No. 747186

(54) Title
Conveyor system

(51)⁷ International Patent Classification(s)
B65G 021/22 E01B 025/10
B65H 029/00 E01B 025/26

(21) Application No: **199914788**

(22) Application Date: **1998.12.17**

(87) WIPO No: **WO99/33720**

(30) Priority Data

(31) Number	(32) Date	(33) Country
2978/97	1997.12.29	CH

(43) Publication Date : **1999.07.19**

(43) Publication Journal Date : **1999.09.23**

(44) Accepted Journal Date : **2002.05.09**

(71) Applicant(s)
IPT Weinfeld AG

(72) Inventor(s)
Jurg Eberle

(74) Agent/Attorney
GRIFFITH HACK,GPO Box 1285K,MELBOURNE VIC 3001

(56) Related Art
US 3999730
DE 4014069
CH 667636

14788199



PCT WELTORGANISATION FÜR GEISTIGES EIGENTUM
Internationales Büro
INTERNATIONALE ANMELDUNG VERÖFFENTLICHT NACH DEM VERTRAG ÜBER DIE
INTERNATIONALE ZUSAMMENARBEIT AUF DEM GEBIET DES PATENTWESENS (PCT)

<p>(51) Internationale Patentklassifikation ⁶ : B65G 21/22, B65H 29/00, E01B 25/10, 25/26</p>	<p>A1</p>	<p>(11) Internationale Veröffentlichungsnummer: WO 99/33720 (43) Internationales Veröffentlichungsdatum: 8. Juli 1999 (08.07.99)</p>
---	------------------	--

<p>(21) Internationales Aktenzeichen: PCT/CH98/00543 (22) Internationales Anmeldedatum: 17. Dezember 1998 (17.12.98) (30) Prioritätsdaten: 2978/97 29. Dezember 1997 (29.12.97) CH (71) Anmelder (für alle Bestimmungsstaaten ausser US): IPT WEINFELDEN AG [CH/CH]; Tannenwiesenstrasse 5, CH-8570 Weinfelden (CH). (72) Erfinder; und (75) Erfinder/Anmelder (nur für US): EBERLE, Jürg [CH/CH]; Bergstrasse 7, CH-8340 Hinwil (CH). (74) Anwalt: FREI PATENTANWALTSBÜRO; Postfach 768, CH-8029 Zürich (CH).</p>	<p>(81) Bestimmungsstaaten: AL, AM, AT, AU, AZ, BA, BB, BG, BR, BY, CA, CH, CN, CU, CZ, DE, DK, EE, ES, FI, GB, GE, GH, GM, HR, HU, ID, IL, IN, IS, JP, KE, KG, KP, KR, KZ, LC, LK, LR, LS, LT, LU, LV, MD, MG, MK, MN, MW, MX, NO, NZ, PL, PT, RO, RU, SD, SE, SG, SI, SK, SL, TJ, TM, TR, TT, UA, UG, US, UZ, VN, YU, ZW, ARIPO Patent (GH, GM, KE, LS, MW, SD, SZ, UG, ZW), eurasisches Patent (AM, AZ, BY, KG, KZ, MD, RU, TJ, TM), europäisches Patent (AT, BE, CH, CY, DE, DK, ES, FI, FR, GB, GR, IE, IT, LU, MC, NL, PT, SE), OAPI Patent (BF, BJ, CF, CG, CI, CM, GA, GN, GW, ML, MR, NE, SN, TD, TG).</p> <p>Veröffentlicht <i>Mit internationalem Recherchenbericht.</i></p> <div data-bbox="890 896 1276 1108" style="border: 1px solid black; padding: 5px; text-align: center;"> <p>IP AUSTRALIA 19 JUL 1999 RECEIVED</p> </div>
--	---

(54) Title: **CONVEYOR SYSTEM**

(54) Bezeichnung: **FÖRDERSYSTEM**

(57) Abstract

The invention relates to a conveyor system provided for conveying along a conveying section (1/2). The system has a guide (3) which extends along the conveying section, and has at least one conveying organ (5) which is guided by the guide (3) and which can be moved along the conveying section by means of a suited drive mechanism. The guide (3) and the conveying organ (5) are provided for conveying a conveyed item in a manner which is essentially unaffected by gravity. In order to connect the conveying section to a plurality of connections (A.1-A.3) according to choice, the conveyor system comprises a variable conveying section area (2) which is connected to an invariable conveying section area (1) with a guide, said guide being mounted in a fixed manner. The guide (3) can be reversibly flexed and turned in the variable conveying section area. A connection means (8) which can be driven is provided for a specific flexing and/or turning of the guide and for holding the guide in a flexed and/or turned position which is necessary for a certain connection. The variable conveying section area (2) is, for example, an end area of the conveying section.

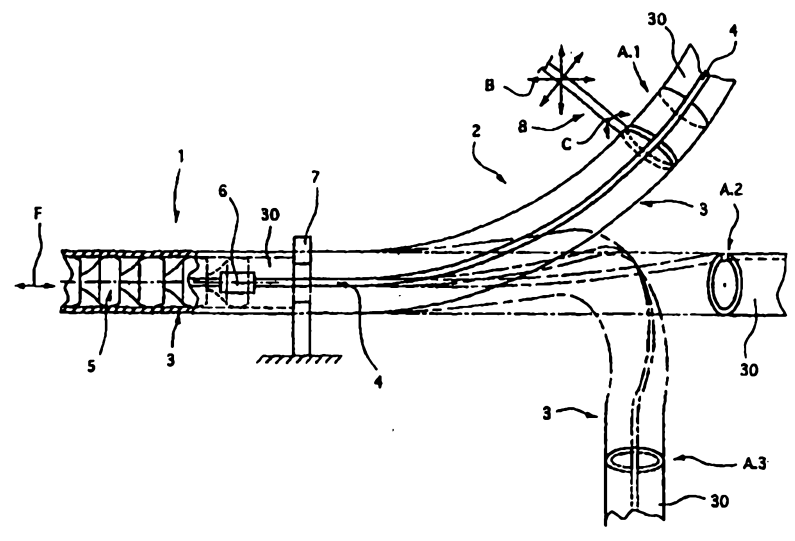

The variable conveying section area (2) is, for example, an end area of the conveying section.

5

ABSTRACT

10 The conveying system serves for conveying items along a conveying line (1/2) and
comprises a guide means (3) extending along the conveying line and at least one
conveying element (5) movable along the conveying line being guided by the guide
means (3). Guide means (3) and conveying element (5) are designed for conveying
the items substantially independently of gravity. For selectable connection of the
15 conveying line to a plurality of connecting points (A.1 - A.3) the conveying system
comprises connected to a invariable conveying line region (1) with a fixedly
mounted guide means, a variable conveying line region (2) in which the guide means
(3) is reversibly bendable and twistable. For bending and/or twisting the guide means
and for supporting the guide means in a bent and/or twisted position necessary for a
20 specific connection, a drivable connecting means (8) is provided. The variable
conveying line region (2) is e.g. an end region of the conveying line.

(Figure 1)

25



CONVEYING SYSTEM

The invention is in the field of conveying technology and relates to a conveying system according to the generic part of the independent claim. The conveying system serves for conveying material to be conveyed along a conveying line and comprises a guide means extending along the conveying line and at least one conveying element being movable along the conveying line with or without the material while being guided by the guide means and being driven by a suitable drive. The guide means and the at least one conveying element are designed such that the movement of the conveying element and conveyance of the material to be conveyed is substantially independent of gravity, i.e. the conveying line can be designed such that conveying element and material to be conveyed can have different spatial positions ~~relative to gravity~~ in different locations of the conveying line.

Conveying systems with a guide means and with at least one conveying element being movable along the guide means for which conveying system the spatial position of the conveying element and the material to be conveyed can be different in different locations of the conveying line, are e.g. known as comprising a conveying chain running in a guide channel and carrying grippers protruding from the channel, wherein each gripper grips an item (material to be conveyed) and supports it during conveyance. This kind of system is in particular known from its application in conveyance of streams of printed products in substantially all possible spatial positions.

Similar systems are known, using instead of a transport chain with a plurality of links, a plurality of conveying elements being independent of each other and being driven individually. Further known are systems combining characteristics of both



systems mentioned above by using a plurality of conveying elements being connected to each other but with distances between each other which are to a limited degree variable.

5

For conveyance to be substantially independent of gravity the guide means of the named conveying systems are e.g. designed to form a cage or channel in which a guided part of the conveying element is enclosed (guided part within guiding part) or to be surrounded by a part of the conveying element (guiding part within guided part). The conveying elements are designed e.g. for gripping and supporting items to be conveyed, they are e.g. grippers.

10

Conveying systems for conveyance in particular of printed products along freely selectable conveying lines and substantially independently of gravity, are e.g. described in the following publications CH-623283 (F086), CH-592562 (F070), EP-387318 (F270).

15

The guide means of conveying systems as described above are usually mounted along a conveying line being predetermined by the conveying function. For simple mounting of the guide means along curved regions of conveying lines bendable guide means have been described, e.g. in the patent applications CH-2917/96 (F444) and CH-801/97 (F453) or in publication EP-0628109 (Richter).

20

Usually switch points are used for connecting the end of a conveying line defined by a fixedly mounted guide means to a selected one of a plurality of further conveying lines or to a selected one of a plurality of different installations. Such switch points e.g. consist of a pivoting guide piece having a restricted length and being hingedly

25

30

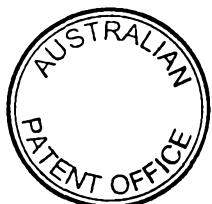

connected the end of the fixedly mounted guide means. This pivoting guide piece can be pivoted such that its distal end facing away from the fixedly mounted guide means connects the fixedly mounted guide means to one or another of the further conveying lines or installations.

5

Such switch points restrict arrangement and design of possible connecting points to be connected with the fixedly mounted guide means within narrow limits. The connecting points must have an exactly defined distance from the end of the fixedly mounted guide means, they must all lie in the pivoting plane of the pivoting guide piece and they must all be designed such that they can take over conveying elements and/or conveyed items with the same orientation defined by guide means of the conveying line further upstream and the switch point. The same is valid for switch points according to CH-558285 (F61) which comprise a bendable guide piece instead of a pivoting guide piece.

10
15

Selectable connection of a conveying system, as described above, to one of two connecting points is in most cases realized by a fixedly mounted guide ramification and a controllable switching element (e.g. flap in a canal ramification) with two positions, whereby the switching element in each one of the two positions forces movement of a passing conveying element to one of the two guide means branching away from the ramification point.

20
25

The object of the invention is to create a conveying system with a guide means extending along a conveying line and with at least one conveying element, which conveying system is selectively connectable to one of a plurality of connecting points. The inventive conveying system is to restrict to a considerably lesser degree than known conveying systems the conditions regarding spatial position of the

30



connecting points and spatial position of the conveyed items. The term "connecting point" is to be understood as an area in which either the at least one conveying element (e.g. together with conveyed items) passes from the guide means of the regarded conveying system to a further guide means (connection to a further, similar
5 conveying system) or in which the conveyed items are transferred from the at least one conveying element of the regarded conveying system (connection to a further different or similar conveying system or to a different installation with transfer of conveyed items).

10

This object is achieved by the conveying system defined in the claims.

The inventive conveying system comprises, following an invariable region of
15 conveying line with a fixedly mounted guide means, a variable conveying line region comprising a guide piece being reversibly bendable and twistable such that the end of this guide piece by predetermined bending and/or twisting is selectively connectable to one of a plurality of connecting points. The variable conveying line region is e.g. the end region of a conveying line. The bendable and twistable guide piece is bent
20 and/or twisted in a predetermined manner and held in the bent and/or twisted position with the aid of a drivable connecting means which e.g. acts on the distal end of the bendable and twistable guide piece.

25 As will be shown further down, the variable region of conveying line does not have to be an end region of a conveying line. An intermediate region of a conveying line can also comprise a bendable and twistable guide piece and thus act as a connecting region.

30



The bending and twisting capacity of the guide means in the variable conveying line region is to be matched to the at least one conveying element such that conveying line curves created by bending and/or twisting have a bending radius which is at least large enough for the curves to be passed by the conveying element without problems.

5

The length of the reversibly bendable and twistable guide piece in the variable conveying line region is advantageously matched to the mechanical stability of the guide means such that the form of this guide piece is defined by its connection with the at least one fixed guide means and the effect of the connecting means and such that it has (advantageously without further devices) a stability sufficient for operation, i.e. is self-supporting.

15 If the guide means in a conveying line end region is bendable the end of the conveying line can be coupled to connecting points at different distances from a fixedly mounted region, arranged in space in any manner, whereby, for different connections, the guide means is bent more or less, in different directions or forming a loop or loops. If the guide means in a conveying line end region is twistable the
20 spatial position of the conveying element and thus of the conveyed items can be matched to specific requirements of each individual connecting point.

The principal function and exemplified embodiments of the inventive conveying system are described in more detail in connection with the following Figures, whereby

Figure 1 shows an exemplified embodiment of the inventive conveying system, the variable conveying line end region of which is selectively connectable to a plurality of similar conveying systems;

30



Figure 2 shows a further, exemplified embodiment of the inventive conveying system the variable conveying line end region of which is selectively connectable to a plurality of different or similar conveying systems or different installations (transfer of conveyed items);

Figures 3 to 7 show exemplified embodiments of bendable and twistable guide means usable in conveying systems according to the invention;

Figure 8 shows a further exemplified embodiment of the inventive conveying system not comprising a variable conveying line end region but a variable conveying line intermediate region;

Figure 9 shows a further exemplified embodiment of the inventive conveying system with two variable conveying line end regions.

Figure 1 very diagrammatically shows a first exemplified embodiment of the inventive conveying system. In this embodiment the connections to further similar conveying systems are designed such that the at least one conveying element is movable across the connecting point and is guided by the guide means of the further similar conveying system beyond the connecting point. Fig 1 shows of the inventive conveying system only one end of an invariable conveying line region 1 with a fixedly mounted guide means and a variable conveying line end region 2 comprising a reversibly bendable and twistable guide piece which is selectably connectable to three different connecting points A.1 to A.3.

The guide means 3, at least in the variable conveying line end region 2, substantially consists of a guide channel 30 (e.g. guide tube) being reversibly bendable and



twistable and comprising a continuous longitudinal slot 4. The conveying element consists of a chain 5 which can be driven by pushing or pulling and which comprises at least one gripping device 6 protruding from the longitudinal slot 4 for gripping one item to be conveyed. For conveyance the chain 5 is driven in the corresponding
5 direction (double arrow F) by a suitable drive (not shown).

In the invariable conveying line region 1 the guide channel 30 (or generally the guide means 3) can in principle be bendable and twistable or not. However, in this region 1
10 the guide channel 30 is fixedly mounted such that the course of the conveying line and the local spatial orientation of the longitudinal slot 4 remain fixed (invariable). This is indicated in Figure 1 by means of a shackle 7, which connects the guide channel 30 with a stationary support.

15 Open ends of similar guide channels 30 with longitudinal slots 4 are provided as connecting points A.1 to A.3. As can be seen from Figure 1, the spatial position of these channel ends is freely selectable within wide limits and the position of longitudinal slot 4 on these channel ends which defines in the connecting point the
20 spatial position of the gripping device 6 and of a conveyed item is independent of the slot position in the invariable conveying line region 1 and for each connecting point it is freely selectable within a wide range.

25 In order to connect the distal end of the variable conveying line end region 2 to connecting point A.1 the bendable and twistable guide means 3 need only be bent and not twisted, because the longitudinal slot 4 has the same spatial orientation where the guide means is fixedly mounted as in connecting point A.1.

30



In order to connect the distal end of the variable conveying line end region 2 to connecting point A.2 the bendable and twistable guide means need not be bent but twisted, because the connection A.2 is arranged on a straight extension of the invariable conveying line region 1 and at a distance corresponding to the length of
5 the bendable and twistable guide piece, but its longitudinal slot 4 is offset by ca. 90° relative to the longitudinal slot of the fixedly mounted guide means.

In order to connect the distal end of the guide piece of the variable conveying line
10 end region 2 to connecting point A.3 the guide means 3 must be bent and twisted by ca. 180°.

For changing connections, drivable connecting means 8 are provided (shown in a
15 very schematic manner). These connecting means 8 are advantageously connected to the distal end of the guide piece of the variable conveying line region and are equipped such that they can move this distal end to each of the connecting points A.1 to A.3 (double arrows B), such that they can twist the distal end around its own axis (double arrow C) and such that they can hold the distal end in each bent and/or
20 twisted position corresponding to any one of the connecting points. The design of the connecting means 8 is to a high degree dependent of the arrangement and the equipment of the connecting points A.1 to A.3, but all the same can be realized without problems by one skilled in the art e.g. with a lever system and a combination of suitably controlled linear motors.

25

When operating the chain shown in Figure 1 as a single conveying element 5 care must be taken that before a change of connection the chain does not reach across the connecting point. Its front end must, therefore, at least be withdrawn into the

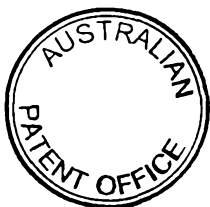

bendable and twistable guide piece or the chain links must be separated in the area of the connecting point before the connection is changed.

5 In publication DE-19604999 (F409) a system is described, which comprises a guide means as illustrated in Fig. 1 and a conveying element in form of a chain being bendable in all directions and applicable in pulling and pushing operation. In this kind of system the end of a conveying line as shown in Figure 1 can be integrated as a switch point function.

10

Conveying elements which are independent of each other can also be moved in a guide means 3, as shown in Fig. 1, e.g. elements as described in patent application CH-2338/96 (F441).

15

Figure 2 shows a further, exemplified embodiment of the inventive conveying system. This embodiment is especially suitable for connections to conveying systems different from the looked at system or to other installations, i.e. it is suitable for connecting points which are passed by the conveyed items only (transfer of items) but not by the conveying element or elements. Again, only one end of the conveying line with an invariable conveying line region 1 and a variable conveying line end-region 2 is shown. The conveying system comprises a double guide means (not shown, e.g. a double channel according to Figure 7), of which the one part defines the conveying path of an endless chain 10 (diagrammatically shown as broken line) and the other part defines the return path of this chain. The distal end of the variable conveying line region is at the same time a point in which the chain 10 is redirected by ca. 180°.

30



The items to be conveyed are e.g. gripped and held on being conveyed by grippers 11 arranged on the chain links and protruding from the guiding channel. Of the grippers 11 only a few are shown as small circles and the conveyed items are shown as narrow rectangles representing e.g. printed products seen in parallel to their main surfaces.

In a connecting point as illustrated by Figure 2 the conveyed items are transferred from the transport element or gripper 11 respectively to a further conveying element of a further conveying system or to a different installation (not shown), i.e. passage of the connecting point always means transfer for the conveyed items.

In Figure 2 three connecting points A.4 to A.6 are shown schematically, whereby the further conveying means or other installations, which take over the conveyed items are not shown and thus are not further defined. It can, however, be seen from Fig. 2 that the three connecting points require different spatial position of the conveyed items 12 and therefore the items must be handed over in different spatial positions, depending on the connection.

At the end of the fixedly mounted guide means (invariable conveying line region 1) the conveyed items 12 are e.g. conveyed in a hanging manner, i.e., the guide means of the conveying path is e.g. arranged below the guide means of the return path. This arrangement is also required for connecting point A.4. In order to connect to A.4 the guide means must thus only be correspondingly bent but not twisted. In connecting point A.5 the items are to be handed over in lying position, i.e. the guide means for the return path is to lie underneath the guide means of the conveying path. The reversibly bendable and twistable guide means of the variable conveying line region 2 must therefore not only be bent for handing over but also be twisted by 180°. For



handing over at connecting point A.6 the bendable and twistable guide means must be bent and twisted by 90°.

5 In the embodiment of the inventive system according to Fig. 2 again, the variable conveying line region 2 can also be arranged in a loop. A loop even of a relatively large bending radius makes it possible to serve different connecting points all lying relatively near to the end of the invariable conveying line region.

10

Figures 3 to 7 show, in more detail, exemplified embodiments of reversibly bendable and twistable guide means 3 applicable in a conveying system according to the invention.

15

Figure 3 shows, in a cross section, a guide means 3 and a conveying element 5 of a conveying system as described in publication EP-387318 (F270) and in the patent application CH-2917/96 (F444). The guide means 3 comprises a guide channel 30 with a longitudinal slot 4 similar to the guide channel a schematically shown in Fig.

20

1. For guiding the internally running conveying element 5 which is a rolling body and comprises groups of three balls 40, rails 50 are arranged within guide channel 30. The rails are fixed to the inner surface of the guide channel e.g. by positive engagement. These rails may extend in parallel to each other over the whole length of the channel 30, are advantageously made of an indestructible material, e.g. of a suitable

25

metal and have e.g. a circular cross section.

30

The guide channel 30 with rails 50 is reversibly bendable and twistable and therefore applicable in a variable conveying line region if it consist of a deformable, advantageously elastically deformable material and if the rails 50 can move to an at



least limited degree in the direction of the conveying line, i.e. in parallel to the channel axis relative to the channel. Rails 50 must also be bendable. If they have a circular cross section they must not necessarily be twistable as long as their fixing in channel 30 allows a rotation in relation to channel 30.

5

Figure 4 shows a further embodiment of a guide means 3 for an inventive conveying system. The guide means serves for guiding an externally running conveying element 5. The guide means comprises a reversibly bendable and twistable guide rod 31, which may be hollow. Rails 50 for rolling bodies 41 of conveying element 5 are arranged on the outside of guide rod 31. For guide rod 31 and rails 50 the same conditions are valid as described above regarding guide channel 30 and rails 50 as illustrated by Fig. 3.

15

Figure 5 shows a further guide means 3, which corresponds regarding function to guide channel 30. The reversibly bendable and twistable channel 30 is, however, replaced by a plurality of distanced channel elements 32 which can be displaced relative to each other due to the flexibility of rails 50 and thus form a reversibly bendable and twistable channel without having to be bendable and twistable themselves.

20

Figure 6 shows a further guide means 3, which regarding function again corresponds to the guide channel of Fig. 3 and which, in the same way as the guide channel of Fig. 5, comprises channel elements 32. The channel elements 32 are mounted on a reversibly bendable and twistable carrier element 33. It is easily possible to mount a second channel on carrier element 33 which channel consists of rails 50 and channel elements 32 and thus to realize the "double channel" according to Figure 2.

25
30

Of course it is possible also to replace the guide rod according to Fig. 4 with rod elements (in analogy to the channel elements 32), which rod elements are combined by means of rails to form a reversibly bendable and twistable guide means.

5

Figure 7 shows a further guide means 3 in the form of a double guide channel, which is applicable in a system according to Figure 2. The guide means again consists of a reversibly bendable and twistable carrier element 33 and of two guide channels mounted on it, the guide channels comprising channel elements 32 and rails 50. A chain, which rolls on rails 50 with rolls 42, e.g. serves as conveying element.

Figure 8 shows an exemplified embodiment of the inventive conveying system with a variable conveying line intermediate region 2, which connects two invariable conveying line regions 1 on both sides. The guide means 3 is shown as guide channel with a longitudinal slot 4. Depending on the position of the variable conveying line region 2 it serves for item transfer at connection points A.7 or A.8, by being connected to one of two further conveying lines 60 or 61 respectively, whereby the position of the longitudinal slot 4 is to be adapted to the position of the same longitudinal slot of the guide means of conveying systems 60 and 61 in the indicated manner by means of twisting guide means 3.

Figure 9 shows a further exemplified embodiment of the inventive conveying system, which is derived from the embodiment according Fig. 1. The conveying line comprises an intermediate, invariable region 2. The corresponding guide means 3 is again shown as guide channel with longitudinal slot 4 and the connecting points A.9 to A.12 as distal ends of similar guide means. With the aid of selectable connection of the one variable conveying line region 2 to connecting points A.9 or A.11 and the

30



other variable conveying line region 2 to connecting points A.10 or A.12, four different connection variants are possible. (A.9 - A.10: shown in unbroken lines; A.11 - A.12: shown in broken lines; A.9 - A.12 and A.11 - A.10: not shown).

5

The shown embodiments of the inventive conveying system are examples and are not intended to limit the invention. Combinations of characteristics other than the shown ones can easily be derived from the description and the Figures and lead to further, possible embodiments of the inventive conveying system.



5

CLAIMS

- 10 1. Conveying system for conveyance along a conveying line (1, 2), which
conveying system comprises guide means (3) extending along the conveying
line and at least one conveying element (5) being movable along the
conveying line guided by the guide means and driven by a suitable drive,
wherein guide means and conveying element are designed for conveyance of
15 items substantially independent of gravity, characterized in that the
conveying line comprises at least one invariable conveying line region (1)
with fixedly mounted guide means and connected to an end of the invariable
conveying line region (1) at least one variable conveying line region (2) with
reversibly bendable and twistable guide means (3) and that for selective
20 connection of the variable conveying line region (2) to one of a plurality of
connecting points (A.1 - A.3, A.4 - A.6, A.7 - A.8, A.9 - A.12) driven
connecting means (8) are provided for selectively bending and/or twisting the
reversibly bendable and twistable guide means (3) of the variable conveying
line region (2).
- 25
2. Conveying system according to claim 1, characterized in that bendability
and twistability of the guide means (3) of the variable conveying line region
(2) is designed such that on bending and/or twisting the bending radii of the

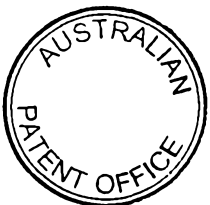

conveying line are matched to conveying properties of the at least one conveying element (5).

- 5
3. Conveying system according to one of claims 1 or 2, characterized in that the bendable and twistable guide means (3) of the variable conveying line region (2) in a connected condition is fixed in its end regions and is self-supporting.
- 10
4. Conveying system according to one of claims 1 to 3, characterized in that the guide means (3) is, at least in the variable conveying line region (2), a reversibly bendable and twistable guide channel (30) with a longitudinal slot (4).
- 15
5. Conveying system according to one of claims 1 to 3, characterized in that the guide means (3), at least in the variable conveying line region (2), is a reversibly bendable and twistable guide rod (31).
- 20
6. Conveying system according to one of claims 4 to 5, characterized in that the guide means (3) additionally comprises a plurality of rails (50) running in parallel to each other and being at least to a limited degree movable in the
- 25
- direction of the conveying line relative to the guide channel (30) or the guide rod (31).



7. Conveying system according to claim 6, **characterized** in that the guide channel or guide rod is formed by a plurality of distanced channel elements (32) or rod elements.

5

8. Conveying system according to one of claims 5 to 7, **characterized** in that the reversibly bendable and twistable guide means (3) comprises a reversibly bendable and twistable carrier element (33) on which a guide channel or a guide rod is mounted.

10

9. Conveying system according to one of claims 1 to 8, **characterized** in that the variable conveying line region (2) is a conveying line end region and its distal end is connectable to a similar conveying system in a manner that the at least one conveying element (5) is movable across the connecting point.

15

10. Conveying system according to claim 8, **characterized** in that on the reversibly bendable and twistable carrier element (33) two guide channels or guide rods are mounted and that on one distal end of the variable conveying line region (2) the guide channel or the guide rod changes direction.

20

11. Conveying system according to claim 10, **characterized** in that the variable conveying line region (2) is a conveying line end region and its end is connectable to a different or similar conveying system or connectable to a different installation.

25



12. Conveying system according to one of claims 1 to 9, **characterized** in that the variable conveying line region (2) is an intermediate conveying line region connected to invariable conveying line regions (1) on both sides.



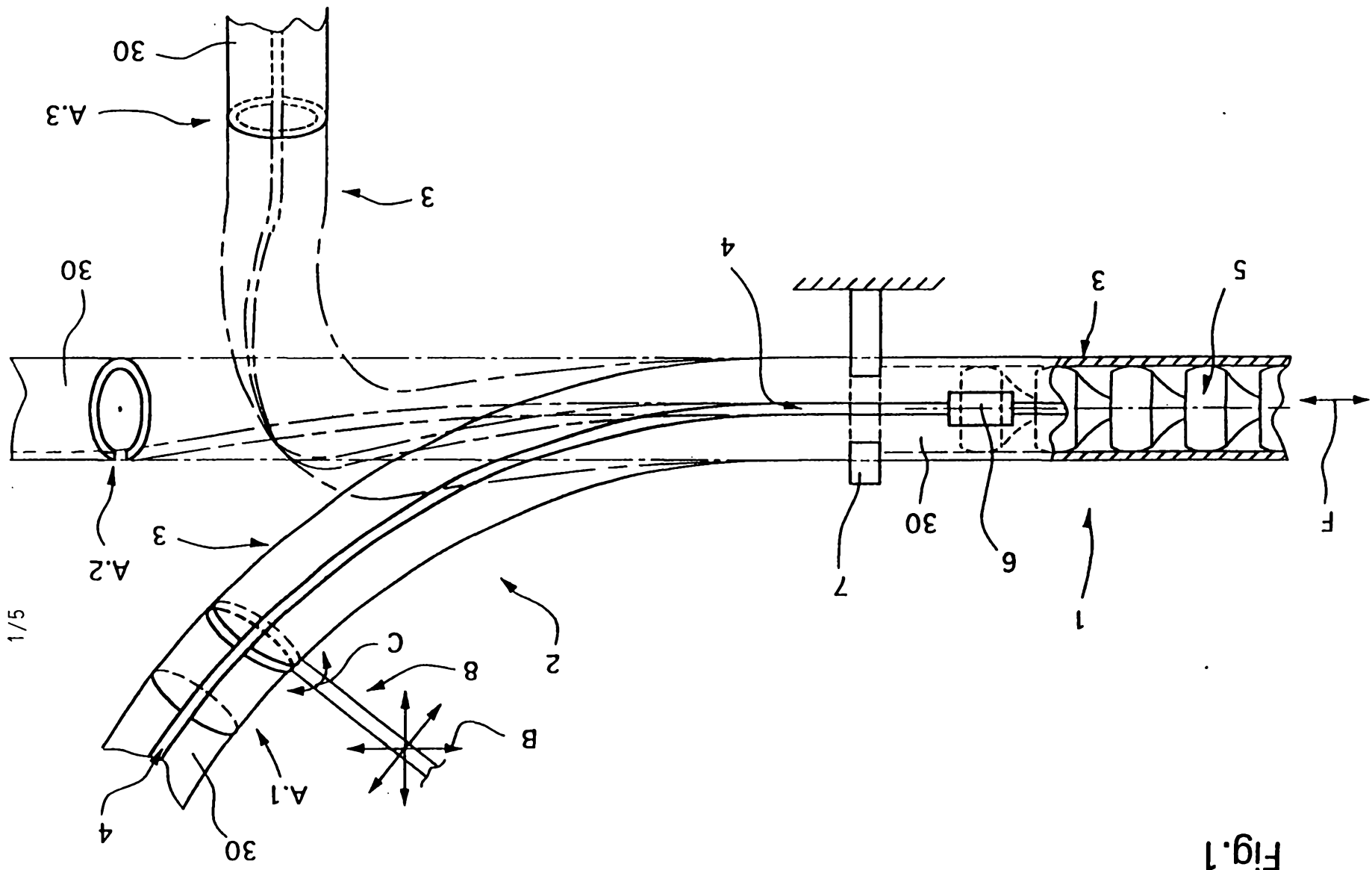

Fig. 1

Fig.2

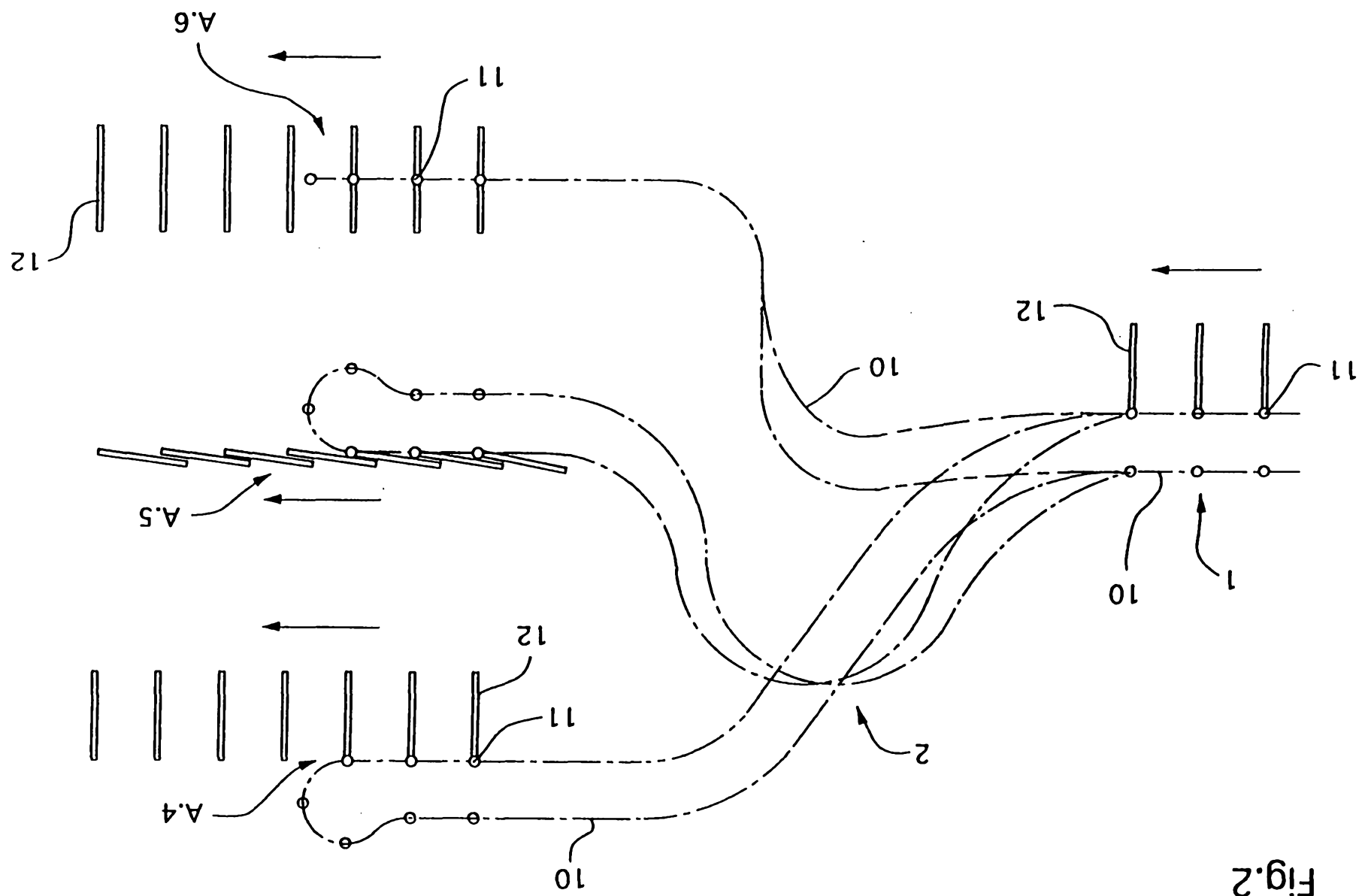

Fig.3

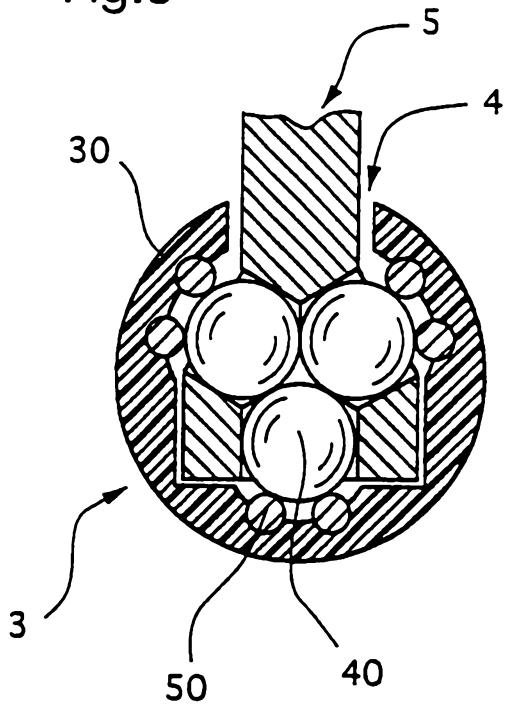

Fig.4

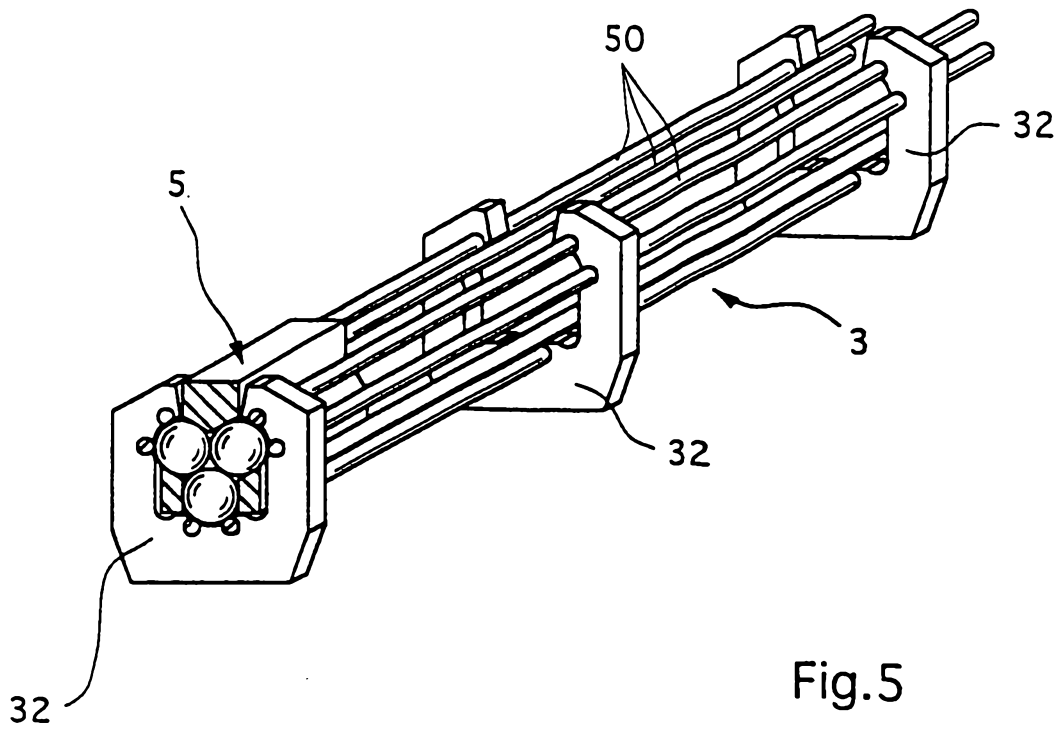
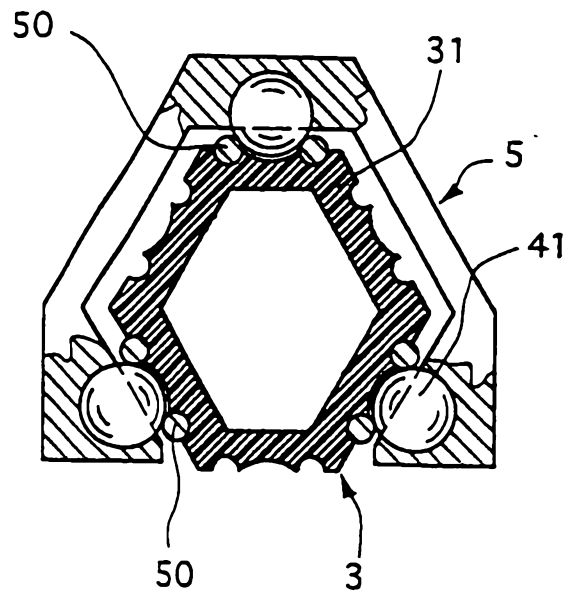

Fig.5

Fig.6

4/5

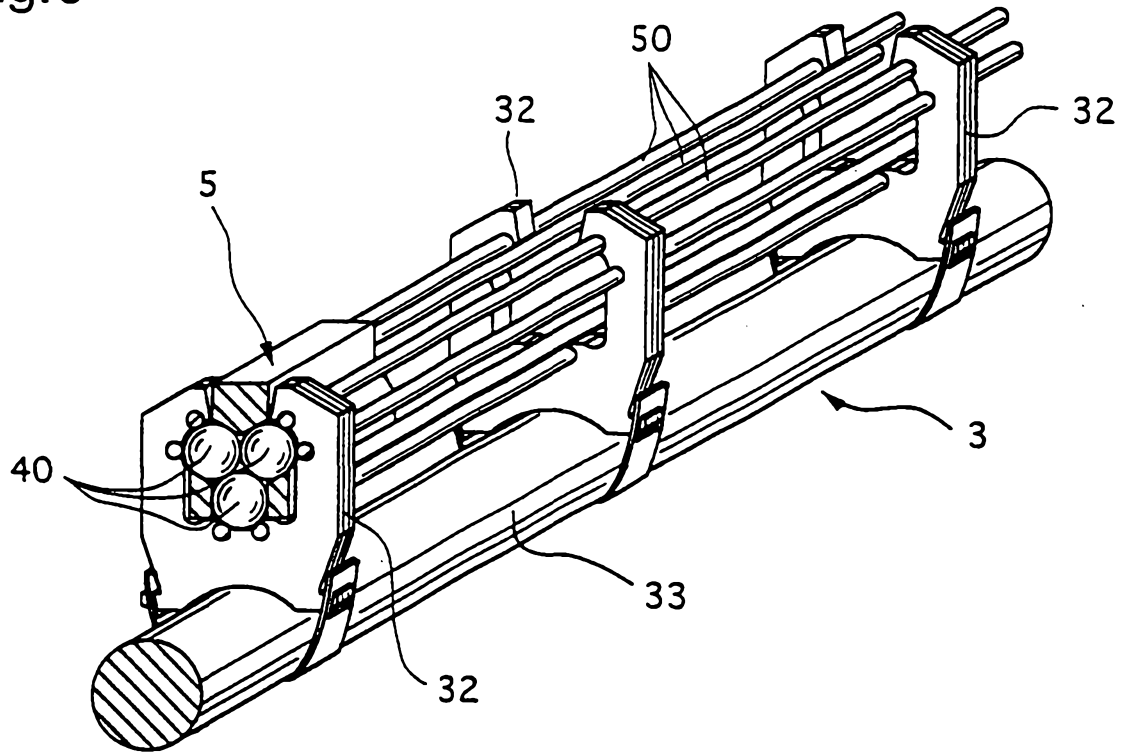

Fig.7

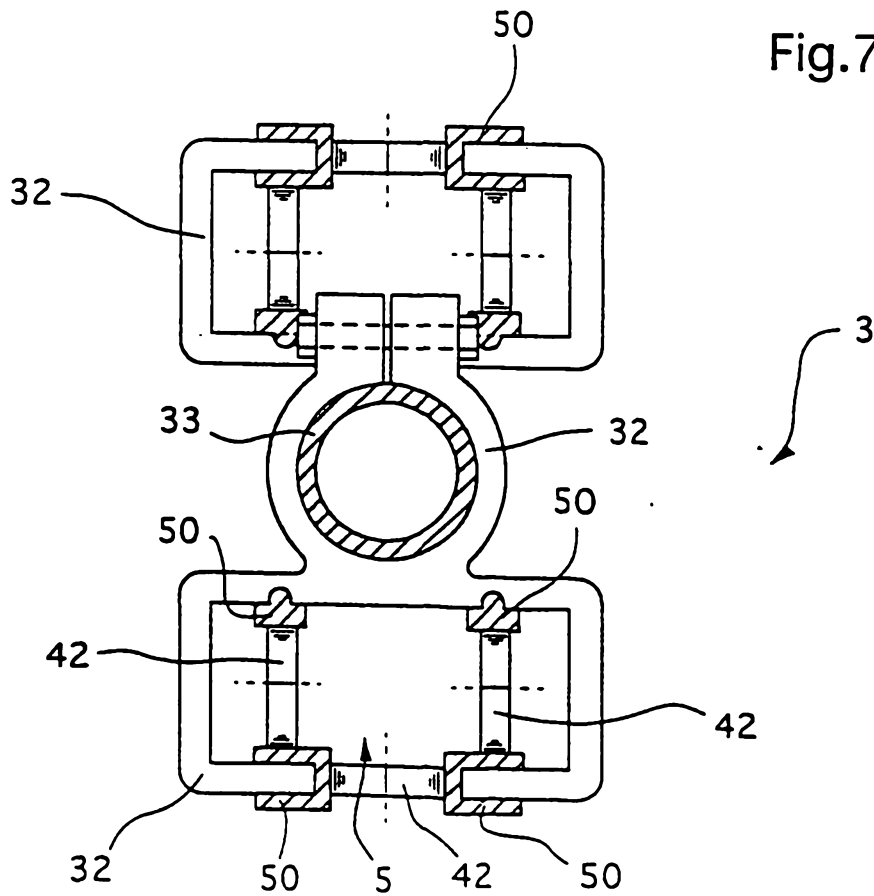

Fig.8

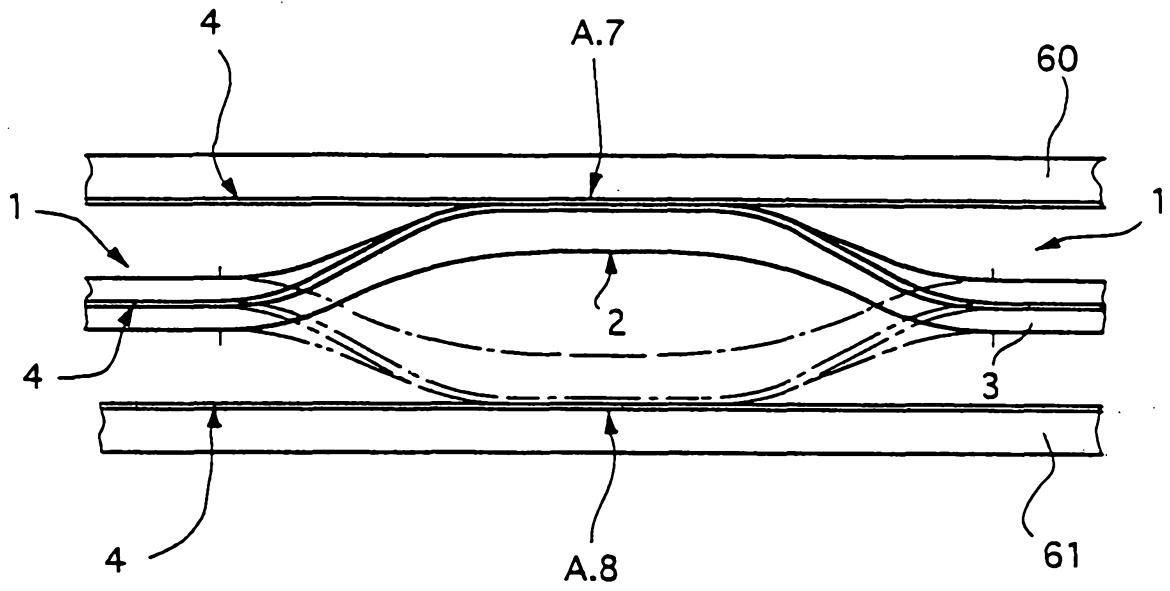

Fig.9

