



INTERNATIONAL APPLICATION PUBLISHED UNDER THE PATENT COOPERATION TREATY (PCT)

<p>(51) International Patent Classification ⁶ : B01J 19/00</p>	<p>A1</p>	<p>(11) International Publication Number: WO 98/10857</p> <p>(43) International Publication Date: 19 March 1998 (19.03.98)</p>
<p>(21) International Application Number: PCT/US97/16343</p> <p>(22) International Filing Date: 11 September 1997 (11.09.97)</p> <p>(30) Priority Data: 60/026,002 12 September 1996 (12.09.96) US</p> <p>(71) Applicant: CHIRON CORPORATION [US/US]; 4560 Horton Street, Emeryville, CA 94608 (US).</p> <p>(72) Inventors: ZUCKERMANN, Ronald; 1126 Keeler Avenue, Berkeley, CA 94708 (US). SIEGMUND, Aaron, C.; 20 Dias Court, El Sobrante, CA 94803 (US). SPEAR, Kerry, L.; Icagen, P.O. Box 14487, Research Triangle Park, NC 27709 (US).</p> <p>(74) Agents: FUJITA, Sharon, M. et al.; Chiron Corporation, Intellectual Property - R440, P.O. Box 8097, Emeryville, CA 94662-8097 (US).</p>		<p>(81) Designated States: AU, CA, JP, European patent (AT, BE, CH, DE, DK, ES, FI, FR, GB, GR, IE, IT, LU, MC, NL, PT, SE).</p> <p>Published With international search report. Before the expiration of the time limit for amending the claims and to be republished in the event of the receipt of amendments.</p>

(54) Title: ACTUATION MEANS FOR USE IN SOLID PHASE CHEMICAL SYNTHESIS INVOLVING ARRAYS OF MODULAR REACTION VESSELS

(57) Abstract

An apparatus is provided for use in solid phase chemical synthesis methods such as the synthesis of polypeptides, peptoids, polynucleotides and other molecules synthesized by solid phase methods. The apparatus includes a plurality of reaction vessels (2, 102, 202, 254) arranged in a substantially linear array (202) wherein the reaction vessels (2, 102, 202, 254) include modular valving means (18, 52, 118, 214) capable of being simultaneously actuated to drain or close each of the reaction vessels (2, 102, 202, 254) in the linear array (202). The invention additionally relates to a plurality of substantially parallel linear arrays (202) of such vessels (2, 102, 202, 254) wherein the valving means (18, 52, 118, 214) of each vessel (2, 102, 202, 254) in a single linear array (202) can be simultaneously actuated.

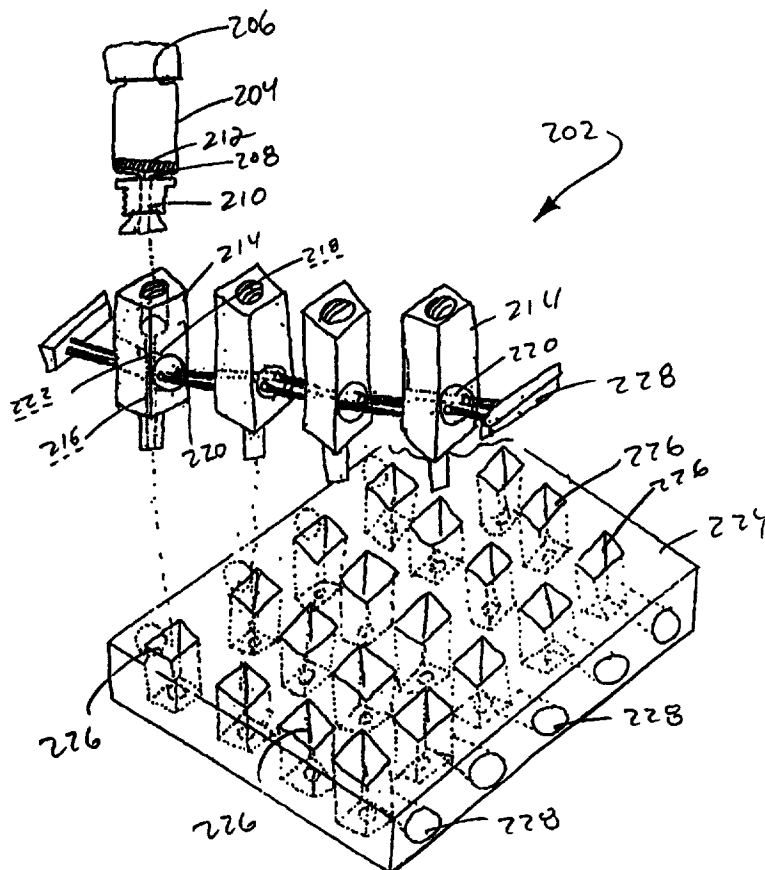

FOR THE PURPOSES OF INFORMATION ONLY

Codes used to identify States party to the PCT on the front pages of pamphlets publishing international applications under the PCT.

AL	Albania	ES	Spain	LS	Lesotho	SI	Slovenia
AM	Armenia	FI	Finland	LT	Lithuania	SK	Slovakia
AT	Austria	FR	France	LU	Luxembourg	SN	Senegal
AU	Australia	GA	Gabon	LV	Latvia	SZ	Swaziland
AZ	Azerbaijan	GB	United Kingdom	MC	Monaco	TD	Chad
BA	Bosnia and Herzegovina	GE	Georgia	MD	Republic of Moldova	TG	Togo
BB	Barbados	GH	Ghana	MG	Madagascar	TJ	Tajikistan
BE	Belgium	GN	Guinea	MK	The former Yugoslav Republic of Macedonia	TM	Turkmenistan
BF	Burkina Faso	GR	Greece	ML	Mali	TR	Turkey
BG	Bulgaria	HU	Hungary	MN	Mongolia	TT	Trinidad and Tobago
BJ	Benin	IE	Ireland	MR	Mauritania	UA	Ukraine
BR	Brazil	IL	Israel	MW	Malawi	UG	Uganda
BY	Belarus	IS	Iceland	MX	Mexico	US	United States of America
CA	Canada	IT	Italy	NE	Niger	UZ	Uzbekistan
CF	Central African Republic	JP	Japan	NL	Netherlands	VN	Viet Nam
CG	Congo	KE	Kenya	NO	Norway	YU	Yugoslavia
CH	Switzerland	KG	Kyrgyzstan	NZ	New Zealand	ZW	Zimbabwe
CI	Côte d'Ivoire	KP	Democratic People's Republic of Korea	PL	Poland		
CM	Cameroon	KR	Republic of Korea	PT	Portugal		
CN	China	KZ	Kazakstan	RO	Romania		
CU	Cuba	LC	Saint Lucia	RU	Russian Federation		
CZ	Czech Republic	LI	Liechtenstein	SD	Sudan		
DE	Germany	LK	Sri Lanka	SE	Sweden		
DK	Denmark	LR	Liberia	SG	Singapore		
EE	Estonia						

ACTUATION MEANS FOR USE IN SOLID PHASE CHEMICAL SYNTHESIS INVOLVING ARRAYS OF MODULAR REACTION VESSELS

Technical Field

The invention relates generally to solid phase chemical synthesis. More particularly, the invention relates to novel reaction vessels and an apparatus containing them in which a new kind of actuation means is incorporated. The invention extends to the synthesis of polypeptides, peptoids, polynucleotides and other syntheses utilizing solid phase organic chemistries.

Background of the Invention

Individual polymers or oligomers of amino acids, nucleotides, or the like, can be easily prepared using conventional solid phase synthetic technologies. For example, a defined polynucleotide can be prepared using conventional phosphoramidite or phosphotriester chemistry. Beaucage *et al.*, *Tetrahedron Lett.* 22:1859-62 (1981); Itakura *et al.*, *J. Biol. Chem.* 250:4592 (1975). A single defined polypeptide can be synthesized using Merrifield solid phase synthetic schemes. Merrifield, *J. Am. Chem. Soc.* 85:2149-2154 (1963); Tam *et al.*, *The Peptides*, Academic Press (New York), pp. 185-249 (1987). Another well-known method for achieving solid-phase peptide synthesis uses 9-fluorenylmethoxycarbonyl (Fmoc) protecting groups on the amino acids (Meienhofer *et al.*, *Int. J. Pept. Protein Res.* 13:35 (1979), Atherton *et al.*, *Bioorg. Chem.* 8:351 (1979)) in which the peptide is immobilized on any of a wide variety of commercially available polystyrene resins (Wang, *J. Am. Chem. Soc.* 95:1328 (1973), Mergler *et al.*, *Tetrahedron Lett.* 29:4005 (1988), Albericio *et al.*, *Int. J. Pept. Protein Res.* 30:206 (1987)).

Methods for the systematic synthesis of a multiplicity of polymers to screen for pharmacological or biological activity have also been developed. Particularly, combinatorial libraries can be prepared containing a large number of polymers using "resin-splitting" or "mix/split" techniques. Furka *et al.*, *Int. J. Peptide Protein Res.*

37:487-493 (1991); Lam *et al.*, *Nature* 354:82-84 (1991). Resin-splitting strategies have also been used to generate mixtures of lower complexity to study ligand-receptor binding activity and enzyme activity structure-activity relationships. Zuckermann *et al.*, *Proc. Natl. Acad. Sci. USA* 89:4505-4509 (1992); Peuthory *et al.*, *Proc. Natl. Acad. Sci. USA* 88:11510-11514 (1991).

Although these methods of synthesis may be routine, they are quite laborious. The difficulty in conducting such syntheses becomes magnified when it is necessary to prepare many specified polypeptide or polynucleotide sequences in parallel, e.g., in the synthesis of combinatorial libraries, such as those containing 10^6 or more components. Accordingly, a number of automated systems for the synthesis of polypeptides and other polymers or oligomers have been developed. One automated system described in Schnorrenberg *et al.*, *Tetrahedron* 45:7759 (1989) relates to the synthesis of peptides on resin using several automated arms to withdraw solvent from a reaction vessel, add a solvent, wash and to mix reagents. Another automated system described in U.S. Patent No. 5,240,680 to Zuckermann *et al.* relates to the synthesis of polypeptides using an apparatus having structure for automated transfer of reaction solutions into and out of a cleavage vessel, peptide solution from the cleavage vessel to the extraction vessel, and transfer of extraction solvent into and out of the extraction vessel.

The use of such automated systems in synthetic polymer production avoids a great deal of technician manipulation and increases the efficiency of synthetic polymer production. However, even with automated systems, a number of steps must still be carried out manually, requiring significant effort and limiting the overall rate of synthetic polymer production. For example, in some automated systems, steps such as rinsing resin from reaction vessels into disposable fritted tubes, drying the resin and transferring the dried resin to new vessels, are problematic with respect to production timing, resin conservation, ease of product identification, and the like.

Accordingly, there remains a need to provide an apparatus for use in the synthesis of polypeptides, peptoids, polynucleotides and other molecules synthesized by solid

phase methods which avoids the need for extensive reaction vessel transfers and/or technician manipulation.

Summary of the Invention

In one embodiment of the invention, an apparatus for conducting chemical syntheses involving a sequence of reaction steps to be conducted on a solid phase is provided. The apparatus includes a plurality of reaction vessels arranged in a substantially linear array, wherein each vessel contains a substrate bearing a solid phase on which chemical synthesis steps are carried out and a passageway through which the vessels may be drained. Each reaction vessel further includes a valving means associated therewith, wherein the valving means is configured to yield a first position allowing drainage of the container and a second position preventing drainage of the container. The valving means is configured to enable the simultaneous draining of the containers in the array, or simultaneous closing of the containers in the array so as to prevent drainage of the vessels.

In one aspect of the invention, a modular reaction vessel for use in solid phase synthesis chemistry is provided. The modular reaction vessel is configured to be arranged in a substantially linear array of like vessels to provide a means for conducting parallel reaction steps in solid phase chemical syntheses such as polynucleotide or polypeptide preparation. The reaction vessels feature a valve body containing a drain that is capable of being simultaneously actuated with the drains in the other vessels in the same array.

In another aspect of the invention, a matrix of reaction vessels is provided. The matrix is formed by a plurality of substantially parallel linear arrays of modular reaction vessels, wherein the vessels in each discrete linear array of vessels in the matrix can be actuated in tandem to the exclusion of vessels in other linear arrays.

The present invention thus also provides an efficient method for carrying out the parallel syntheses of a plurality of compounds in a plurality of reaction vessels.

Brief Description of the Figures

Figure 1 is a cross-sectional view of an embodiment of the reaction vessel of the invention having a container disposed within a modular valve body.

Figure 2 is a pictorial representation of a linear array of reaction vessels coupled together in the array by an actuation means capable of simultaneously actuating the valves in the entire array of vessels.

Figure 3 is a cross-sectional view of another embodiment of the reaction vessel of the invention having optional locking and sealing means which provides a liquid-tight and pressure-tight interface between the container and the modular valve body.

Figure 4 is an exploded view of a linear array of reaction vessels and their alignment within an associated rack.

Figure 5 is an exploded view of a linear array of reaction vessels and their operative relationship to various associated devices for use in conducting chemical syntheses within the reaction vessels.

Detailed Disclosure of the Invention

The practice of the methods of the present invention will employ, unless otherwise indicated, conventional techniques of synthetic organic chemistry including solid-phase synthesis, peptide synthesis, polynucleotide synthesis, polysaccharide synthesis, and other solid phase organic chemistries, that are within the skill of the art. Such techniques are explained fully in the literature. *See, e.g.*, Thompson *et al.*, "Synthesis and Applications of Small Molecule Libraries," *Chem Rev.* 96:55-600 (1996); Terrett *et al.*, "Combinatorial Synthesis - The Design of Compound Libraries and Their Application to Drug Discovery," *Tetrahedron* 51(30):8135-8173 (1995); Kirk-Othmer's Encyclopedia of Chemical Technology; House's Modern Synthetic Reactions; C.S. Marvel and G. S. Hiers' text, *ORGANIC SYNTHESIS*, Collective Volume 1; Oligonucleotide Synthesis (M.J. Gait, ed., 1984); and a series, Methods in Enzymology (Academic Press, Inc.).

All patents, patent applications, publications and other types of references cited herein, whether *supra* or *infra*, are hereby incorporated by reference in their entirety.

Definitions

5 Before the present invention is disclosed and described in detail, it is to be understood that this invention is not limited to specific assay formats, materials or reagents, as such may, of course, vary. It is also to be understood that the terminology used herein is for the purpose of describing particular embodiments only and is not intended to be limiting.

10 It must be noted that, as used in the specification and the appended claims, the singular forms "a," "an" and "the" include plural referents unless the context clearly dictates otherwise. Thus, for example, reference to "a reaction vessel" includes two or more such vessels, reference to "an actuation means" includes two or more such actuation means, and the like.

15 In this specification and in the claims which follow, reference will be made to a number of terms which shall be defined to have the following meanings:

The term "monomer" as used herein refers to a chemical entity that may be covalently linked to one or more other entities to form an oligomer. Monomers are subunits that include, for example, amino acids, nucleotides, saccharides, alkylators, nucleophiles, and the like.

20 The term "solid phase" intends any solid support or substrate on which the reaction steps of chemical syntheses involving a sequence of reaction steps can be carried out. Thus, the term includes particulate substrates such as polystyrene resins which have traditionally been employed in standard Fmoc chemical syntheses.

25 The term "substantially linear" as used herein to describe an array of reaction vessels refers to an arrangement of such vessels wherein the novel actuation means of the invention can be used to simultaneously actuate the draining of all of the vessels in the array using the methods and devices described herein.

The term "pressure-tight," when used herein in reference to a particular seal or an interface between two components, refers to the capability of such seal or interface to withstand pressures of at least about 5 psi, more preferably at least about 10 to 15 psi, and most preferably at least about 20 psi, without leaking (e.g., allowing the passage of
5 gases therethrough).

In one embodiment of the invention, an apparatus is provided for conducting chemical syntheses involving reaction steps that are conducted on a solid phase. The apparatus includes a plurality of reaction vessels arranged in a linear array. The reaction vessels are operatively coupled to each other in the linear array by way of a novel valving
10 means which enables a broad range of synthetic manipulations to be carried out in parallel. More particularly, each of the reaction vessels in the linear array contains a substrate bearing a solid phase on which chemical syntheses involving a sequence of reaction steps can be carried out. The vessels have an upper opening through which chemical reagents can be introduced, and a lower opening through which the vessels can
15 be drained.

The architecture of the reaction vessels is particularly well suited for use in the parallel synthesis of polypeptides, peptoids, polynucleotides and other synthetic organic chemistries that are synthesized by solid phase methods in which monomeric units are added step-wise to a growing polymer chain immobilized on a solid support. The
20 substrates disposed within the vessels physically retain the solid support, e.g., discrete particles such as resins or polymer beads, and allow for efficient mixing between reactants contained within the vessels and the supports. The lower "drain" opening allows separation of solid support-bound intermediates from excess reagents, solvents and byproducts. By forming a linear array of such vessels, a plurality of compounds can
25 be simultaneously, but separately, synthesized to generate an array of compounds.

In the present apparatus, the reaction vessels are arranged together in the array by means of a unique valving system which is configured such that simultaneous manipulations of all of the vessels in the array can be carried out in a single step. Specifically, each reaction vessel has a modular valving means associated therewith. The

modular valving means is operatively associated with the lower drain opening in the reaction vessel, allowing the vessel to be sealed, or opened to drain therethrough. The valving means also contains an actuation means which cooperates with a universal mechanism capable of simultaneously actuating all of the valving means in a linear array
5 between their respective sealed and open positions.

Referring now to Figure 1, an embodiment of a modular reaction vessel is generally indicated at 2. The vessel includes a container 4 having a top opening 6, and a bottom opening 8 comprised of a protruding elongate conduit 10 with an upstream terminus 12 and a downstream terminus 14. The container 4 has an integral filter
10 substrate 16 disposed within the container and arranged above the upstream terminus 12 of the elongate conduit 10. The filter substrate 16 physically supports a solid phase on which solid phase synthesis chemistry can be carried out.

The modular reaction vessel 2 further includes a valve body, generally indicated at 18, having an upper surface 20 and a lower surface 22 with a vertical bore 24
15 extending therebetween. A horizontal bore 26 is arranged in valve body 18 such that the major axis thereof is substantially normal to the major axis of vertical bore 24, thereby dividing the vertical bore into an upper portion 28 and lower portion 30. Upper surface 20 of the valve body contains a valve seat 32 coaxially aligned with the vertical bore 24 and configured to accept and retain the elongate conduit 10 of the container 4.

20 As may be seen in Figure 1, a barrel drain 34 is disposed within the horizontal bore 26. A drain bore 36 extends through the body 38 of the barrel drain. Actuation means 40 allows the barrel drain to be rotated between a first position wherein the drain bore 36 is coaxially aligned with the vertical bore 24 in the valve body 18 and allows fluid communication between upper portion 28 and lower portion 30 of the vertical bore
25 via drain bore 36. In this position, container 4 can be drained to separate solid phase-bound intermediates that are retained in the container by the filter substrate 16, from excess reagents, solvents and byproducts. In this "drainage" position, the reaction container can also be drained to isolate the desired synthesized molecules from the retained solid phase support in a cleavage step. The barrel drain 34 can also be rotated to

a second position wherein the outer surface of the body 38 of the barrel drain blocks passage of reagents or products from the container 4 by preventing fluid communication between upper and lower portions 28 and 30 of vertical bore 24. Actuation means 40 is adapted such that the barrel drains in at least two valve bodies can be actuated
5 simultaneously when two or more modular reaction vessels are disposed in a substantially linear array of reaction vessels.

The modular reaction vessel 2 is specially adapted for use in solid phase synthesis chemistry reactions in which a sequence of reaction steps are carried out in parallel using a plurality of reaction vessels. The container 4 can be comprised of any suitable material selected for chemical inertness and physical resiliency. Thus, the container can be
10 comprised of Pyrex® or any other suitable borosilicate or other material commonly used in the construction of chemical reaction containers. Borosilicate materials are generally preferred. Further, the container 4 can comprise external threads disposed around the periphery of the top opening 6 to facilitate the liquid- and/or pressure-tight closure of the
15 container using a threaded cap.

The use of borosilicate materials in the construction of the container 4 also facilitates formation of the protruding elongate conduit 10 which extends from the bottom of the container, i.e., because borosilicate structures can be formed by glass drawing techniques that are routine in the art. Further, this process readily allows the
20 addition of the integral filter substrate 16 in the container 4 during formation of the reaction container.

The filter substrate can be comprised of any material capable of retaining common solid supports on which chemical syntheses are conducted. The filter substrate material should also be chemically inert with respect to the reagents used in the chemical
25 syntheses conducted in the reaction vessels, durable, reusable and generally nondeformable over multiple uses. The filter generally has a mesh size ranging from about 10 to about 50 μm , although much larger mesh sizes are equally suitable for use in vessels where "pins" or "crowns" are to be used as the solid support. Geysen *et al.*,

Bioorg. Med. Chem. Ltr. 3:397-404 (1993). In one particular vessel, filter substrate 16 is a glass frit having, for example, a 16 to 40 μm filter size.

In the above-described modular reaction vessel, several component interfaces provide sealing surfaces and hence require the selection of various suitable component materials. In this regard, the materials used to construct the various components of the valve body 18 and barrel drain 34 are carefully selected to provide reliable sealing when the barrel drain is closed, while still allowing movement of the barrel drain within the valve body. The valve body 18 can be formed from any suitable chemically inert polymeric material that is also substantially rigid and nonexpanding. For example, the valve body can be formed from a poly(chlorotrifluoroethylene) such as Kel-F® or the like.

The use of substantially rigid, nonexpanding materials in the construction of the valve body 18 allows for compression fitting of a compressible barrel drain 34 within the horizontal bore 26 of the valve body. More specifically, the material used in the construction of the barrel drain should have good frictional characteristics relative to the valve body material. By providing a compressible barrel drain for use in a valve body comprised of a substantially rigid material, one is able to achieve a positive pressure- and liquid-tight seal between those components by compression fitting the compressible barrel drain 34 within the horizontal bore 24 of the rigid valve body 18. Selection of a barrel drain material that has good frictional characteristics relative to the valve body material enables rotation of the barrel drain within the valve body without compromising the sealing between those materials. Thus, when the valve body is comprised of a poly(chlorotrifluoroethylene), the barrel drain can be comprised of high density polyethylenes which have superior frictional characteristics relative to such valve body materials. Alternatively, the barrel drain 34 can be comprised of a polymeric material that is chemically inert and structurally sound, yet compressible, such as polytetrafluoroethylene (e.g., Teflon®).

In the reaction vessel of Figure 1, the actuation means 40 of the barrel drain 34 is shown as comprising a pair of key bores which extend through the barrel drain and are

arranged such that the major axis of the drain bore 36 is substantially normal to the major axes of the key bores. The key bores depicted in Figure 1 are disposed on opposite sides of the drain bore in the barrel drain. The key bores allow actuation of the barrel drain between its first and second positions by a turning key that fits within the bores.

5 Such key bores can be configured in any suitable geometry, such as oval, semi-circular, C-shaped or D-shaped to accommodate complementary-shaped turning keys. In alternative embodiments, the actuation means 40 can comprise a single key bore shaped as described above, or a plurality of bores arranged on one or both sides of the drain bore.

10 Referring now to Figure 2, a linear array of modular valve bodies is generally indicated at 52. The array comprises a plurality of valve bodies 54 having barrel drains 56 disposed within horizontal bores 58 extending through the valve bodies 54. The barrel drains contain drain bores 60 which allow communication between upper and lower portions of vertical bores 62 which extend through the valve bodies 54. The barrel
15 drains also contain first and second key bores, respectively indicated at 64 and 66, which cooperate with a turning key 68 capable of simultaneously actuating the barrel drains 56 in each of the valve bodies 54 disposed in the linear array 52. The turning key 68 is formed from a suitable material that exhibits little or substantially negligible twist such that the turning key can simultaneously actuate each of the barrel drains 56 to accurately
20 align the drain bores 60 with the upper and lower portions of the vertical bores 62. For example, the turning key 68 can be formed from two tungsten/carbide rods which extend through the key bores 64 and 66. Tungsten/carbide materials are selected herein due to the high modulus of elasticity of such composite materials; however, any other material having a high modulus of elasticity can be substituted therefor in the construction of the
25 turning keys.

Referring again to the vessel of Figure 1, another component interface in the modular reaction vessel 2 comprises the mating surface between the elongate conduit 10 and the valve seat 32 in the valve body 18. In particular, this interface provides a sealing surface that needs to be both liquid- and pressure-tight in order to facilitate use of such

reaction vessels in common solid phase synthesis processes. In one embodiment wherein the valve body is comprised of a substantially rigid polymer such as poly(chlorotrifluoroethylene), the container 4 can be formed from a substantially rigid borosilicate and configured such that the external diameter of the elongate conduit 10 and the internal diameter of the valve seat 32 provide for a tight compression-fit between the elongate conduit and the valve body. In alternative embodiments, a biasing means, such as a spring clip or other tensioning device, can be used to maintain the conduit firmly in place within the valve seat 32 to provide a liquid-tight and/or pressure-tight seal.

Referring now to Figure 3, an alternative embodiment of a modular reaction vessel is generally indicated at 102. The reaction vessel includes a container 104 having a top opening 106 and a bottom opening 108 comprised of a protruding elongate conduit 110 with an upstream terminus 112 and a downstream terminus 114.

The modular reaction vessel 102 also includes a valve body, generally indicated at 118, having an upper surface 120 and a lower surface 122 with a vertical bore 124 extending therebetween. A horizontal bore 126 is arranged in the valve body 118 such that the major axis thereof is substantially normal to the major axis of the vertical bore 124, thereby dividing the vertical bore into an upper 128 and lower 130 portion. The upper surface 120 of the valve body contains a valve seat 132 that is coaxially aligned with the vertical bore 124 and configured to accept and retain the elongate conduit 110 of the container 104.

To facilitate a tightly sealed coupling between the elongate conduit 110 and the valve seat 132, an optional annular sealing means 150 is provided which encircles the base of the elongate conduit and engages with a mating notch 152 arranged within the valve seat 132. The annular sealing means thus provides a liquid-tight interface between the conduit and the valve body. The annular sealing means can be formed from any suitable gasket or sealing material. In one particular vessel embodiment, the sealing means is comprised of a compressible polymeric material poly(ethylenetetrafluoroethylene), for example Tefzel®, and is configured as a flangeless ferrule.

In the reaction vessel **102**, the valve seat **132** contains optional lock means for detachably coupling the elongate conduit **110** with the valve body **118** to provide a pressure-tight interface therebetween. In particular, the valve seat **132** comprises internal threads **154** which engage a threaded coupler **156** which holds the elongate conduit in place relative to the valve body and provides a resilient pressure-tight seal between those two components of the modular reaction vessel **102**. The threaded coupler **156** can include optional means for tightening and loosening the hold on the elongate conduit, such as wherein the coupler is an externally-threaded hex nut. Other alternative embodiments include configurations in which the elongate conduit **110** is held in place relative to the valve body **118** via a snap-coupling arrangement and other suitably interchangeable fastening arrangements commonly employed by those skilled in the art to provide liquid- and pressure-tight interfaces between various materials.

The above-described modular reaction vessels are adapted to be operatively arranged together to form linear ordered arrays for use in parallel solid phase synthesis chemistry. Referring now to Figure 4, a linear ordered array **202** of modular reaction vessels is shown in exploded view to illustrate the various components thereof. In particular, a plurality of reaction vessels are provided having a container **204** with a top opening **206**, a bottom opening **208** comprised of a protruding elongate conduit **210**, and an internally disposed filter substrate **212** arranged above the elongate conduit **210** and capable of retaining a solid phase within the container. Each container **204** is disposed within a modular valve body **214** which contains a vertical bore **216** and a horizontal bore **218** disposed within the valve body as previously described hereinabove. A barrel drain **220** is arranged within each horizontal bore **218**. The barrel drain can be switched between a first position in which a drain bore **222** extending through the barrel drain is aligned with the vertical bore **216** extending through the valve body **214** thereby allowing communication of contents from the container **204** through the valve body, and a second position which prevents communication through the valve body as also described hereinabove.

The array **202** of modular reaction vessels is maintained in linear spaced apart relation to each other within a rack **224** having a plurality of receptacles **226** configured to retain the array of reaction vessels. An actuation means **228** is provided which enables simultaneous actuation of the barrel drains **220** (e.g., between their respective first and second positions) in each reaction vessel arranged in the linear array **202**. As can be seen, a number of like arrays can be retained within the rack **224**, wherein the barrel drains in each of the vessels present in discrete linear arrays can be simultaneously actuated by an individual actuation means. In this manner, a matrix can be formed by a plurality of linear arrays of two or more such modular reaction vessels. Chemical synthesis steps can be conducted in parallel in each discrete linear array. In this regard, the rack **224** also contains openings **230** which accommodate the insertion of actuation means **228** for each linear array. The openings **230** also allow metallic or semi-metallic actuation means to be readily removed from the arrays, such as where it is desired to insert the rack **224** and reaction vessels into a microwave for a quick temperature adjustment. After heating, the actuation means can be easily reinserted.

The present invention thus provides a method for carrying out parallel reaction steps in the solid phase chemical synthesis of a plurality of compounds, said method comprising:

- (i) providing a plurality of reaction vessels arranged in a linear array in a rack for holding the vessels, wherein each vessel (a) contains a substrate bearing a solid phase on which the reaction steps are carried out and (b) has associated with it a valving means configured to yield a first position allowing drainage of the vessel and a second position preventing drainage of the vessel;
- (ii) optionally coupling said reaction vessel to said valving means by a lock means;
- (iii) introducing a reagent or solvent to each vessel;
- (iv) carrying out one or more chemical reaction steps on said solid phase; and
- (v) simultaneously actuating each said valving means to said first position to enable simultaneous draining of said vessels.

In the practice of the invention, linear arrays of reaction vessels can be comprised of any number of individual containers, and matrices formed from such linear arrays can be comprised of any number of discrete linear arrays. The spacing between vessels in each linear array, and between linear arrays of vessels in a matrix, can be adjusted to
5 accommodate the use of various liquid handling devices such as multi-channel pipettors, aspirators and the like which can have a wide degree of variation in the spacing of individual liquid channeling means. Further, the vessels can be arranged relative to each other in such a way as to facilitate the placement or removal of screw-cap closures for the containers, where it is convenient to have adequate finger space between vessels in order
10 to manipulate individual caps.

The vessel array depicted in Figure 4 is designed for ready use with associated devices, such as vacuum manifolds which facilitate the simultaneous draining of reagents from linear arrays of vessels, collection racks which can be used to retain filtrates from the vessels and temperature control devices which can be used to provide various
15 reaction conditions for chemical syntheses conducted within the reaction vessels. Referring now to Figure 5, a rack **252** is shown which contains a plurality of linear arrays of reaction vessels **254**, wherein all of the barrel drains in each linear array are individually actuated by an actuation means **256** coupled to that array. The rack **252**, containing one or more linear arrays of reaction vessels, can be placed upon an associated
20 vacuum manifold **258**, having means **260** for connecting the manifold with a vacuum source. In use, the rack **252** can be placed in vacuum-tight relation with the vacuum manifold **258** which is then evacuated to provide a vacuum under the reaction vessels contained within the rack. Upon actuation of an actuation means **256**, the barrel drains in each of the reaction vessels can be opened, thereby allowing communication of excess
25 reagents, solvents, byproducts from the reaction vessels to drain into the vacuum manifold for collection by an associated waste receptacle during washing steps. A gasket **262**, such as a closed-cell foam comprised of a polyethylene, can be placed between the rack **252** and the lid **264** of the vacuum manifold **258** to improve the vacuum-tight seal between those components.

In another reaction step, such as a cleavage step, a collection rack **266**, containing a plurality of collection vials that correspond to each reaction vessel **254** included in the rack **252**, can be inserted into the vacuum manifold **258** prior to placing the rack **252** into operative position with the vacuum manifold. In this manner, the filtrates from each
5 reaction vessel can be individually collected and retained by the collection vials. In yet further reaction steps, a temperature control element **270**, configured to fit over the top of each reaction vessel **254** in the rack **252**, can be applied to regulate or adjust the temperature in the reaction vials. In one embodiment, the temperature control element **270** is comprised of an aluminum block having heating elements attached thereto which
10 can be placed over the reaction vials **254** to incubate the vessels at elevated temperatures.

It is to be understood that while the invention has been described above in conjunction with preferred specific embodiments thereof, the description is intended to illustrate and not limit the scope of the invention, which is defined by the scope of the appended claims.

We Claim

1. An apparatus for conducting chemical syntheses involving a sequence of reaction steps to be conducted on a solid phase, comprising:

a plurality of reaction vessels arranged in a linear array in a rack for holding the vessels, wherein each vessel contains (a) a substrate bearing a solid phase on which the reaction steps are carried out, (b) an opening through which reagents may be introduced, and (c) a passageway through which the vessel may be drained, and

a valving means associated with each vessel, configured to yield a first position allowing drainage of the vessel and a second position preventing drainage of the vessel, said valving means enabling simultaneous draining of the vessels or simultaneous closing of the vessels, preventing drainage thereof.

2. The apparatus of claim 1, comprising a plurality of substantially parallel linear arrays of reaction vessels wherein the valving means enables simultaneous draining or simultaneous closing of the vessels in a single linear array.

3. The apparatus of claim 1, wherein said passageway comprises a protruding elongate conduit with an upstream terminus and a downstream terminus.

4. The apparatus of claim 3, wherein said valving means comprises a valve body having an upper surface and a lower surface with a vertical bore extending therebetween and a horizontal bore arranged in the valve body such that the major axis of the horizontal bore is substantially normal to the major axis of the vertical bore and divides the vertical bore into an upper portion and a lower portion, wherein the upper surface of the valve body contains a valve seat coaxially aligned with the vertical bore and configured to accept and retain the elongate conduit.

5. The apparatus of claim 4, wherein the valve seat is configured to accept an annular sealing means which fits around the elongate conduit and provides a liquid-tight and pressure-tight interface between said conduit and the valve body.

6. The apparatus of claim 5, wherein the valve seat further comprises a lock means for detachably coupling the elongate conduit with the valve body to provide a pressure-tight interface therebetween.

7. A matrix formed by a plurality of substantially parallel linear arrays of two or more modular reaction vessels for use in solid phase chemical synthesis, wherein:

(a) each reaction vessel comprises (i) a container having a top opening, a bottom opening comprised of a protruding elongate conduit with an upstream terminus and a downstream terminus and a filter means disposed within the container and arranged above the upstream terminus of the elongate conduit, (ii) a valve body having an upper surface and a lower surface with a vertical bore extending therebetween and a horizontal bore arranged in the valve body such that the major axis of the horizontal bore is substantially normal to the major axis of the vertical bore and divides the vertical bore into an upper portion and a lower portion, wherein the upper surface of the valve body contains a valve seat coaxially aligned with the vertical bore and configured to accept and retain the elongate conduit, and (iii) a barrel drain having a drain bore extending therethrough and an actuation means, wherein said barrel drain is disposed within the horizontal bore in the valve body and can be rotated to a first position in which the drain bore is coaxially aligned with the vertical bore thereby allowing communication between the upper and lower portions of the vertical bore, and to a second position wherein the barrel drain prevents communication between the upper and lower portions of the vertical bore;

(b) each linear array of reaction vessels is maintained in linear order within a rack configured to retain a plurality of reaction vessels; and

(c) the actuation means enables simultaneous actuation of the barrel drains in a single linear array of reaction vessels.

8. The matrix of claim 7, further comprising elongate turning keys extending through the actuation means of each reaction vessel in a single linear array so as to enable simultaneous actuation of the barrel drains in each reaction vessel of a single linear array.

9. A substantially linear array of two or more modular reaction vessels for use in solid phase chemical synthesis, wherein:

(a) each reaction vessel comprises (i) a container having a top opening, a bottom opening comprised of a protruding elongate conduit with an upstream terminus and a downstream terminus and a filter means disposed within the container and arranged above the upstream terminus of the elongate conduit, (ii) a valve body having an upper surface and a lower surface with a vertical bore extending therebetween and a horizontal bore arranged in the valve body such that the major axis of the horizontal bore is substantially normal to the major axis of the vertical bore and divides the vertical bore into an upper portion and a lower portion, wherein the upper surface of the valve body contains a valve seat coaxially aligned with the vertical bore and configured to accept and retain the elongate conduit, and (iii) a barrel drain having a drain bore extending therethrough and an actuation means, wherein said barrel drain is disposed within the horizontal bore in the valve body and can be rotated to a first position in which the drain bore is coaxially aligned with the vertical bore thereby allowing communication between the upper and lower portions of the vertical bore, and to a second position wherein the barrel drain prevents communication between the upper and lower portions of the vertical bore;

(b) said array of reaction vessels is maintained so that the reaction vessels are in linear spaced apart relation to each other within a rack configured to retain a plurality of such reaction vessels; and

(c) the actuation means enables simultaneous actuation of the barrel drains in each reaction vessel in the array.

10. The linear array of claim 9, further comprising an elongate turning key extending through the actuation means of each reaction vessel in the array so as to enable simultaneous actuation of the barrel drains in each reaction vessel on the array.

11. A modular reaction vessel for use in solid phase chemical synthesis, comprising:

(a) a container having a top opening, a bottom opening comprised of a protruding elongate conduit with an upstream terminus and a downstream terminus and a filter means disposed within the container and arranged above the upstream terminus of the elongate conduit;

(b) a valve body having an upper surface and a lower surface with a vertical bore extending therebetween and a horizontal bore arranged in the valve body such that the major axis of the horizontal bore is substantially normal to the major axis of the vertical bore and divides the vertical bore into an upper portion and a lower portion, wherein the upper surface of the valve body contains a valve seat coaxially aligned with the vertical bore and configured to accept and retain the elongate conduit; and

(c) a barrel drain having a drain bore extending therethrough and actuation means, wherein said barrel drain is disposed within the horizontal bore in the valve body and can be rotated to a first position in which the drain bore is coaxially aligned with the vertical bore thereby allowing communication between the upper and lower portions of the vertical bore.

12. The reaction vessel of claim 11, wherein the valve seat is configured to accept an annular sealing means which fits around the elongate conduit and provides a liquid-tight and pressure-tight interface between said conduit and the valve body.

13. The reaction vessel of claim 11 wherein the valve seat further comprises lock means for detachably coupling the elongate conduit with the valve body to provide a pressure-tight interface therebetween.

14. The reaction vessel of claim 12 wherein the valve seat further comprises lock means for detachably coupling the elongate conduit with the valve body to provide a pressure-tight interface therebetween.

15. The reaction vessel of claim 13 wherein the lock means comprises thread means disposed within the valve body for engaging a threaded coupler that holds the elongate conduit in place relative to the valve body.

16. The reaction vessel of claim 11 wherein the filter means comprises an integral glass frit.

17. The reaction vessel of claim 11 wherein the valve body is comprised of an inert polymeric material.

18. The reaction vessel of claim 17 wherein the polymeric material is substantially rigid.

19. The reaction vessel of claim 18 wherein the polymeric material is a poly(chlorotrifluoroethylene).

20. The reaction vessel of claim 11 wherein the barrel drain is compression-fit within the horizontal bore in the valve body.

21. The reaction vessel of claim 11 wherein the barrel drain is comprised of an inert polymeric material.

22. The reaction vessel of claim 21 wherein the polymeric material is compressible.
23. The reaction vessel of claim 22 wherein the barrel drain is compression-fit within the horizontal bore in the valve body.
24. The reaction vessel of claim 21 wherein the polymeric material is a high density polyethylene.
25. The reaction vessel of claim 11 wherein the barrel drain is comprised of polytetrafluoroethylene.
26. The reaction vessel of claim 11 wherein the actuation means comprises a key bore extending through the barrel drain and arranged such that the major axis of the key bore is substantially normal to the major axis of the drain bore.
27. The reaction vessel of claim 26 wherein the key bore is C-shaped.
28. The reaction vessel of claim 26 wherein the key bore is D-shaped.
29. The reaction vessel of claim 11 wherein the actuation means comprises first and second key bores extending through the barrel drain and arranged such that the major axes of said key bores are substantially normal to the major axis of the drain bore.

30. A method for carrying out parallel reaction steps in the solid phase chemical synthesis of a plurality of compounds, said method comprising:

(i) providing a plurality of reaction vessels arranged in a linear array in a rack for holding the vessels, wherein each vessel (a) contains a substrate bearing a solid phase on which the reaction steps are carried out and (b) has associated with it a valving means configured to yield a first position allowing drainage of the vessel and a second position preventing drainage of the vessel;

(ii) optionally coupling said reaction vessel to said valving means by a lock means;

(iii) introducing a reagent or solvent to each vessel;

(iv) carrying out one or more chemical reaction steps on said solid phase; and

(v) simultaneously actuating each said valving means to said first position to enable simultaneous draining of said vessels.

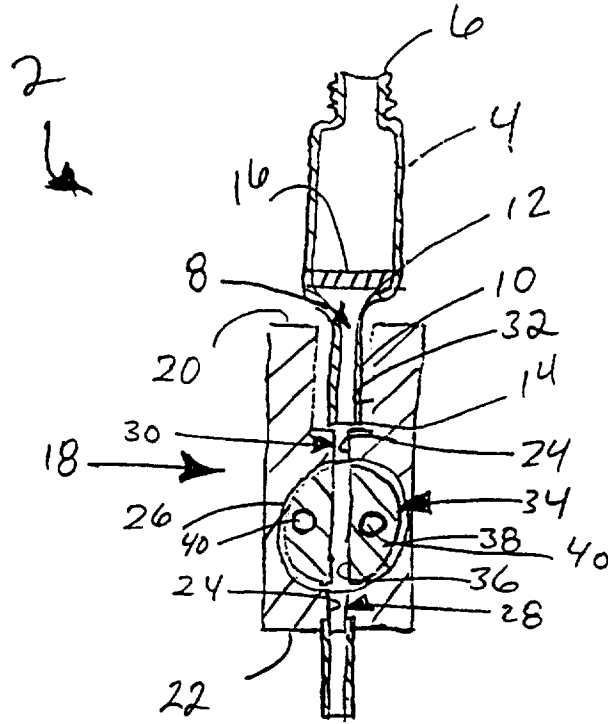

FIG. 1

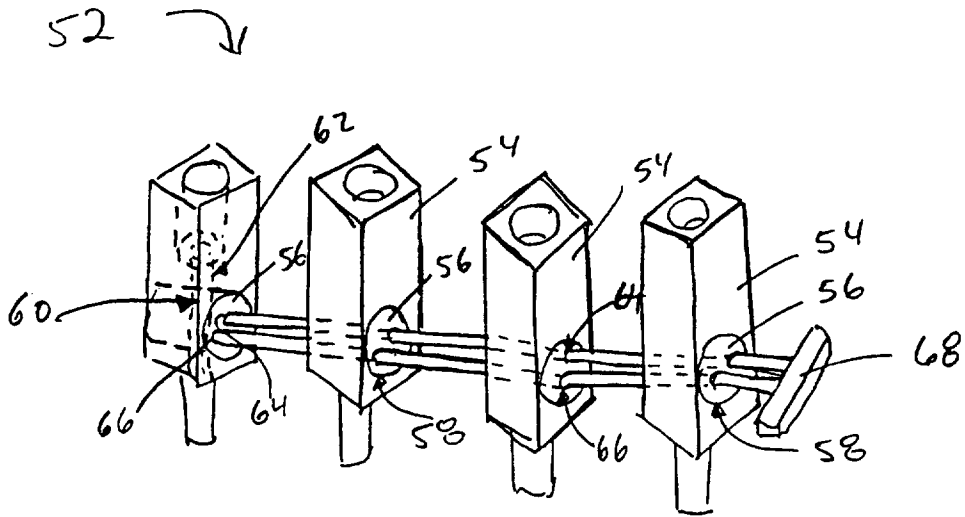

FIG. 2

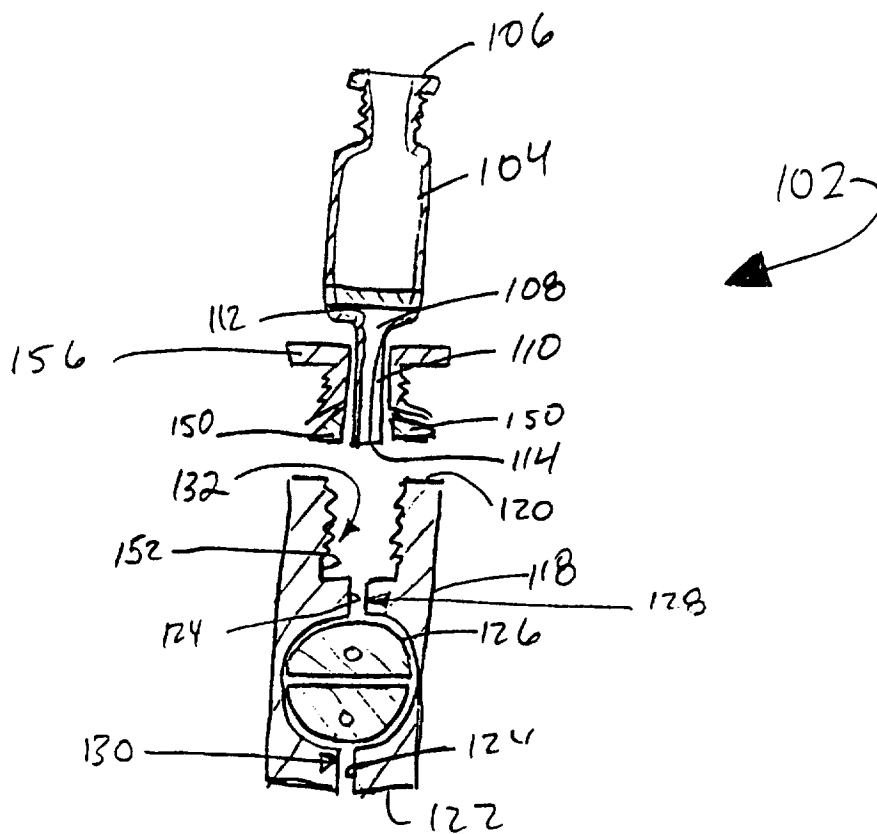

FIG. 3

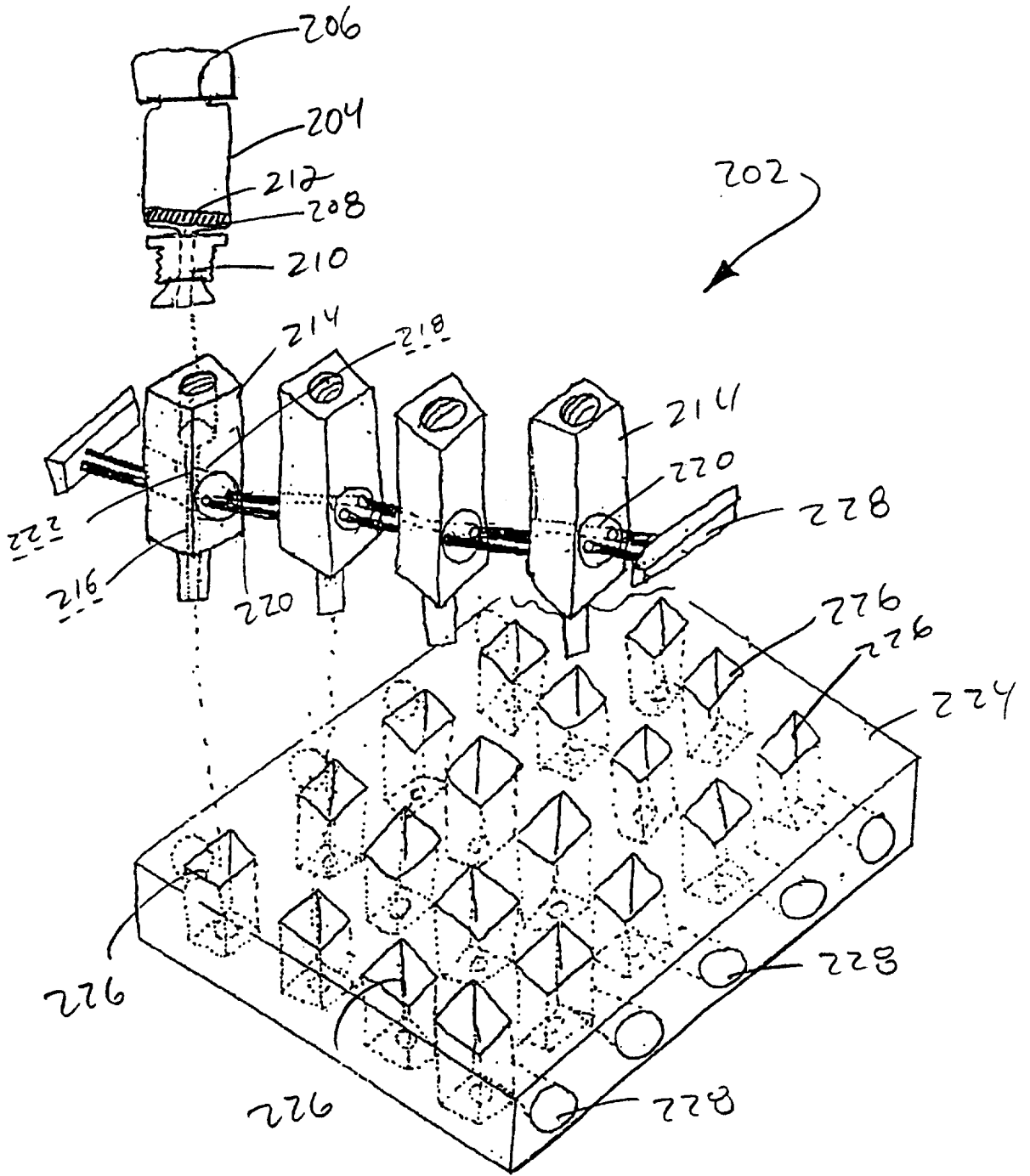

FIG. 4

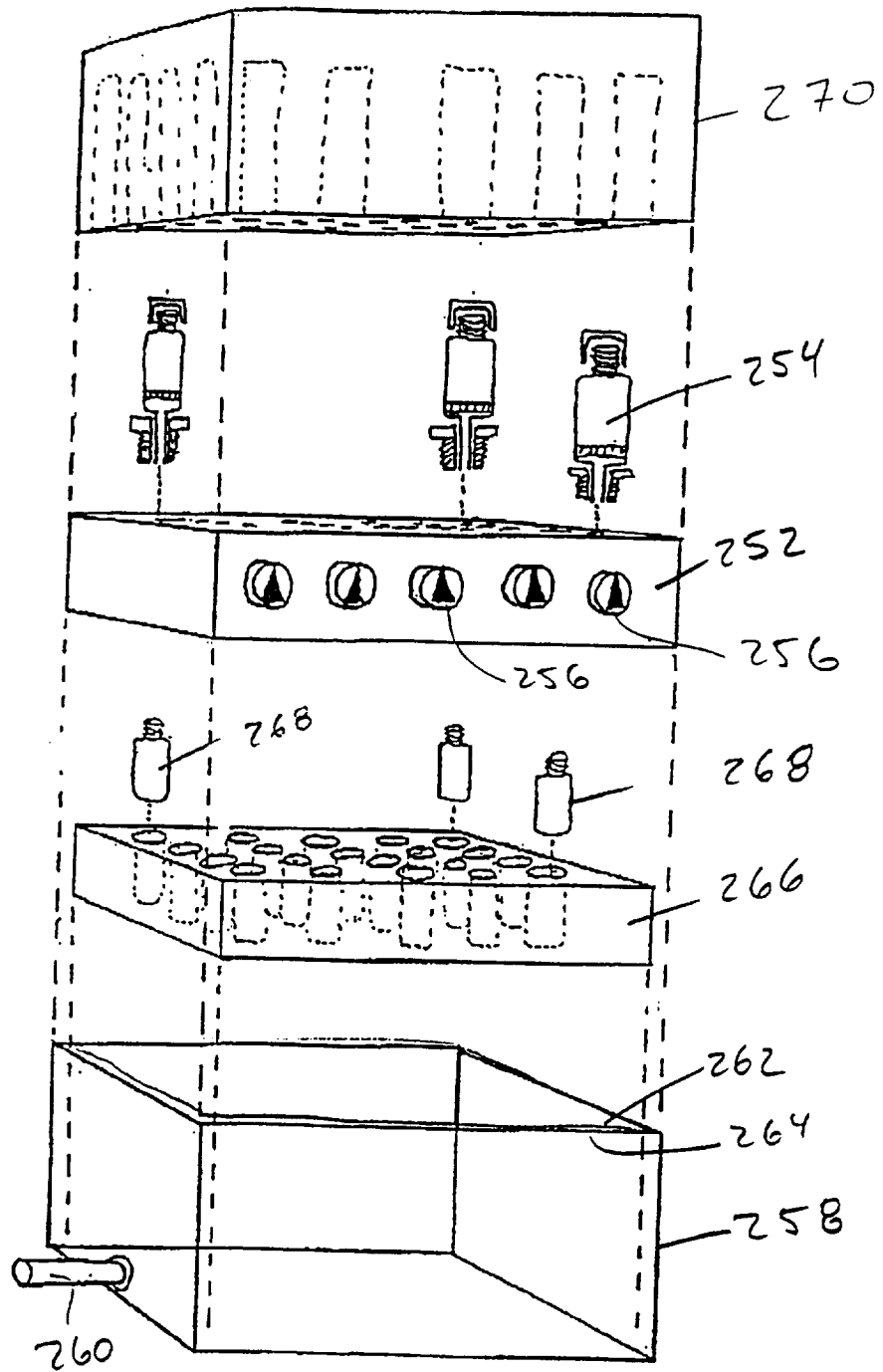

FIG. 5

INTERNATIONAL SEARCH REPORT

International Application No
PC1/US 97/16343

A. CLASSIFICATION OF SUBJECT MATTER
IPC 6 B01J19/00

According to International Patent Classification (IPC) or to both national classification and IPC

B. FIELDS SEARCHED

Minimum documentation searched (classification system followed by classification symbols)
IPC 6 B01J C07K B01L

Documentation searched other than minimum documentation to the extent that such documents are included in the fields searched

Electronic data base consulted during the international search (name of data base and, where practical, search terms used)

C. DOCUMENTS CONSIDERED TO BE RELEVANT

Category	Citation of document, with indication, where appropriate, of the relevant passages	Relevant to claim No.
X A X A P, X P, A	<p>DE 40 08 085 A (ABIMED ANALYSEN-TECHNIK GMBH) 19 September 1991 see the whole document</p> <p style="text-align: center;">---</p> <p>US 5 053 454 A (AMRIT K. JUDD) 1 October 1991 see the whole document</p> <p style="text-align: center;">---</p> <p>WO 97 10896 A (BERLEX LABORATORIES, INC.) 27 March 1997 see abstract see page 12, line 28 - page 13, line 26 see figures 1-6</p> <p style="text-align: center;">---</p>	<p>1-3, 30</p> <p>7, 9, 11</p> <p>11, 16, 26</p> <p>1, 3-10, 12-14, 20, 30</p> <p>1-11, 16, 26, 30</p> <p>12-14, 20</p>
-/--		

Further documents are listed in the continuation of box C.

Patent family members are listed in annex.

* Special categories of cited documents :

- "A" document defining the general state of the art which is not considered to be of particular relevance
- "E" earlier document but published on or after the international filing date
- "L" document which may throw doubts on priority claim(s) or which is cited to establish the publication date of another citation or other special reason (as specified)
- "O" document referring to an oral disclosure, use, exhibition or other means
- "P" document published prior to the international filing date but later than the priority date claimed

"T" later document published after the international filing date or priority date and not in conflict with the application but cited to understand the principle or theory underlying the invention

"X" document of particular relevance; the claimed invention cannot be considered novel or cannot be considered to involve an inventive step when the document is taken alone

"Y" document of particular relevance; the claimed invention cannot be considered to involve an inventive step when the document is combined with one or more other such documents, such combination being obvious to a person skilled in the art.

"&" document member of the same patent family

Date of the actual completion of the international search

Date of mailing of the international search report

7 January 1998

15/01/1998

Name and mailing address of the ISA

European Patent Office, P.B. 5818 Patentlaan 2
NL - 2280 HV Rijswijk
Tel. (+31-70) 340-2040. Tx. 31 651 epo nl.
Fax: (+31-70) 340-3016

Authorized officer

Stevnsborg, N

INTERNATIONAL SEARCH REPORT

International Application No

PCT/US 97/16343

C.(Continuation) DOCUMENTS CONSIDERED TO BE RELEVANT		
Category	Citation of document, with indication, where appropriate, of the relevant passages	Relevant to claim No.
A	WO 93 12427 A (CHIRON CORPORATION) 24 June 1993 cited in the application see page 5, line 17 - line 30 see figures 2,3 ---	13-15
A	US 5 503 805 A (JEFFREY J. SUGARMAN ET AL.) 2 April 1996 -----	

INTERNATIONAL SEARCH REPORT

Information on patent family members

International Application No

PCT/US 97/16343

Patent document cited in search report	Publication date	Patent family member(s)	Publication date
DE 4008085 A	19-09-91	NONE	
US 5053454 A	01-10-91	NONE	
WO 9710896 A	27-03-97	AU 7241796 A	09-04-97
WO 9312427 A	24-06-93	US 5240680 A	31-08-93
US 5503805 A	02-04-96	AU 1128095 A	23-05-95
		BR 9407947 A	26-11-96
		CN 1134156 A	23-10-96
		EP 0726906 A	21-08-96
		GB 2298863 A	18-09-96
		JP 9508353 T	26-08-97
		NZ 276860 A	22-09-97
		WO 9512608 A	11-05-95
		US 5665975 A	09-09-97